

# RV1S9207A

R08DS0220EJ0100

Rev.1.00

Mar 29,2021

0.6 A OUTPUT CURRENT, HIGH CMR, IGBT GATE DRIVE,  
5-PIN SSOP (LSSO5) PHOTOCOUPLER

## DESCRIPTION

The RV1S9207A is an optical coupled isolator containing an AlGaAs LED on the input side and a photo diode, a signal processing circuit and power output MOS FETs on the output side on one chip.

The RV1S9207A is designed specifically for high common mode transient immunity (CMR) and high switching speed. It is suitable for driving IGBTs and MOS FETs.

## FEATURES

- Small and long creepage (8.2 mm MIN, LSSO5)
- Peak output current (0.6 A MAX., 0.4 A MIN.)
- High speed switching ( $t_{PLH}$ ,  $t_{PHL}$  = 150 ns MAX.)
- High common mode transient immunity ( $CM_H$ ,  $CM_L$  =  $\pm 50$  kV/ $\mu$ s MIN.)
- Operating Ambient Temperature (125 °C MAX.)
- High isolation voltage (BV = 5 000 Vr.m.s.)
- Embossed tape product : RV1S9207ACCSP-10Yx#KC0 : 3 500 pcs/reel
- Pb-Free product
- Safety standard
  - UL : UL1577, Double protection
  - CSA : CAN/CSA-C22.2 No.62368-1, Reinforced insulation
  - VDE : DIN EN 60747-5-5 (Option)

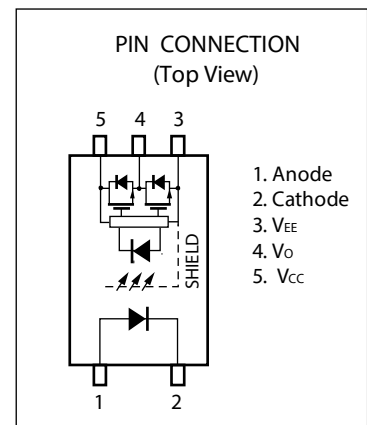

## APPLICATIONS

- IGBT, Power MOS FET Gate Driver
- Industrial inverter
- AC Servo

Start of mass production  
Feb.2021

PACKAGE DIMENSIONS (UNIT : mm)

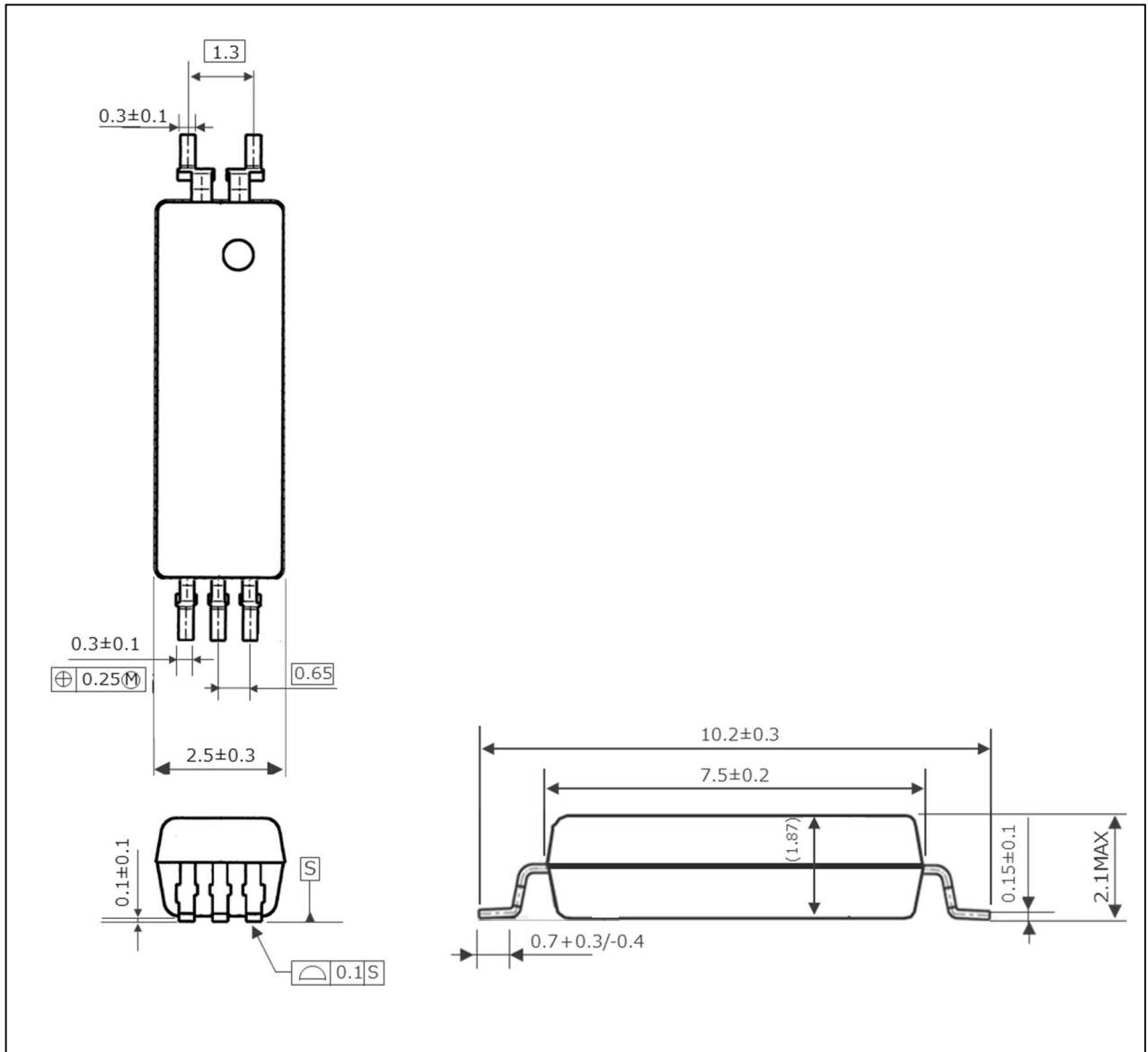

Weight :0.075g (Typ.)

PHOTOCOUPLER CONSTRUCTION

Parameter	MIN.
Air Distance	8.2 mm
Creepage Distance	8.2 mm
Isolation Distance	0.15 mm

## MARKING EXAMPLE

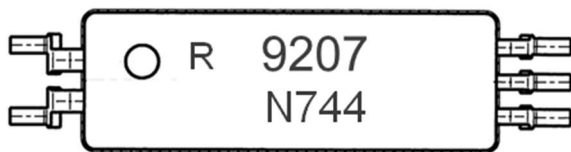

R		An initial of "Renesas"	
9207		Product Part Number *	
○		No.1 pin Mark	
N744	N	Rank Code	
	744	Assembly Lot	
		7	Last one-digit of Assembly Year
		44	Weekly Serial Code

\* ) Applicable type numbers listed below

RV1S 9207 ACCSP-10Yx

Marking type number. "RV1S" and "ACCSP-10Yx" are omitted from original type number.

## ORDERING INFORMATION

Part Number	Order Number	Solder Plating Specification	Packing Style	Safety Standard Approval	Application Part Number*1
RV1S9207ACCSP-10YC	RV1S9207ACCSP-10YC#SC0	Pb-Free and Halogen Free (Ni/Pd/Au)	20 pcs (Tape 20 pcs cut)	Standard products (UL, CSA approved)	RV1S9207A
	RV1S9207ACCSP-10YC#KC0		Embossed Tape 3 500 pcs/reel		
RV1S9207ACCSP-10YV	RV1S9207ACCSP-10YV#SC0		20 pcs (Tape 20 pcs cut)	UL, CSA, DIN EN 60747-5-5 approved	
	RV1S9207ACCSP-10YV#KC0		Embossed Tape 3 500 pcs/reel		

Notes:\*1. For the application of the Safety Standard, following part number should be used.

ABSOLUTE MAXIMUM RATINGS ( $T_A = 25\text{ }^\circ\text{C}$ , unless otherwise specified)

Parameter		Symbol	Ratings	Unit
Diode	Forward Current	$I_F$	20	mA
	Peak Transient Forward Current (Pulse Width < 1 $\mu\text{s}$ )	$I_{F(\text{TRAN})}$	1.0	A
	Reverse Voltage	$V_R$	5	V
	Power Dissipation Derating	$\Delta P_D/^\circ\text{C}$	1.2 ( $T_A \geq 110\text{ }^\circ\text{C}$ )	mW/°C
	Power Dissipation	$P_D$	45	mW
Detector	High Level Peak Output Current *2	$I_{OH(\text{PEAK})}$	0.6	A
	Low Level Peak Output Current *2	$I_{OL(\text{PEAK})}$	0.6	A
	Supply Voltage	$V_{CC}-V_{EE}$	0 to 35	V
	Output Voltage	$V_O$	0 to $V_{CC}$	V
	Power Dissipation Derating	$\Delta P_C/^\circ\text{C}$	3.9 ( $T_A \geq 85\text{ }^\circ\text{C}$ )	mW/°C
	Power Dissipation	$P_C$	250	mW
Isolation Voltage *1		BV	5 000	Vr.m.s.
Operating Frequency		f	250	kHz
Operating Ambient Temperature		$T_A$	-40 to +125	°C
Storage Temperature		$T_{\text{stg}}$	-55 to +150	°C

Notes: \*1. AC voltage for 1 minute at  $T_A = 25\text{ }^\circ\text{C}$ , RH = 60 % between input and output.

Pins 1-2 shorted together, 3-5 shorted together.

\*2. Maximum pulse width = 10  $\mu\text{s}$ , Maximum duty cycle = 0.5 %

## RECOMMENDED OPERATING CONDITIONS

Parameter	Symbol	MIN.	TYP.	MAX.	Unit
Supply Voltage	$V_{CC} - V_{EE}$	10		30	V
Forward Current (ON)	$I_{F(\text{ON})}$	8	10	12	mA
Forward Voltage (OFF)	$V_{F(\text{OFF})}$	-2		0.8	V
Operating Ambient Temperature	$T_A$	-40		125	°C

**ELECTRICAL CHARACTERISTICS (at RECOMMENDED OPERATING CONDITIONS,  $V_{EE} = \text{GND}$ , unless otherwise specified)**

Parameter		Symbol	Conditions	MIN.	TYP.* 1	MAX.	Unit
Diode	Forward Voltage	$V_F$	$I_F = 10 \text{ mA}$ , $T_A = 25 \text{ }^\circ\text{C}$	1.35	1.56	1.75	V
	Reverse Current	$I_R$	$V_R = 3 \text{ V}$ , $T_A = 25 \text{ }^\circ\text{C}$			10	$\mu\text{A}$
	Input Capacitance	$C_t$	$V_F = 0 \text{ V}$ , $f = 1 \text{ MHz}$ , $T_A = 25 \text{ }^\circ\text{C}$		30		pF
Detector	High Level Output Current	$I_{OH}$	$V_O = (V_{CC} - 4 \text{ V})^{*2}$	0.2			A
			$V_O = (V_{CC} - 10 \text{ V})^{*3}$	0.4			
	Low Level Output Current	$I_{OL}$	$V_O = (V_{EE} + 2.5 \text{ V})^{*2}$	0.2			A
			$V_O = (V_{EE} + 10 \text{ V})^{*3}$	0.4			
	High Level Output Voltage	$V_{OH}$	$I_O = -100 \text{ mA}^{*4}$	$V_{CC} - 3.0 \text{ V}$	$V_{CC} - 1.5 \text{ V}$		V
	Low Level Output Voltage	$V_{OL}$	$I_O = 100 \text{ mA}$		0.25	1.0	V
	High Level Supply Current	$I_{CCH}$	$V_O = \text{Open}$ , $I_F = 10 \text{ mA}$		1.4	2.0	mA
	Low Level Supply Current	$I_{CCL}$	$V_O = \text{Open}$ , $V_F = 0 \text{ to } 0.8 \text{ V}$		1.3	2.0	mA
	UVLO Threshold	$V_{UVLO+}$	$V_O > 5 \text{ V}$ , $I_F = 10 \text{ mA}$		8.6	9.8	V
$V_{UVLO-}$		6.8		8.2			
UVLO Hysteresis	$UVLO_{HYS}$			0.4			
Coupled	Threshold Input Current (L $\rightarrow$ H)	$I_{FLH}$	$I_O = 0 \text{ mA}$ , $V_O > 5 \text{ V}$		2.2	5.0	mA
	Threshold Input Voltage (H $\rightarrow$ L)	$V_{FHL}$	$I_O = 0 \text{ mA}$ , $V_O < 5 \text{ V}$	0.8			V

Notes: \*1. Typical values at  $T_A = 25 \text{ }^\circ\text{C}$ ,  $V_{CC} - V_{EE} = 30 \text{ V}$ .

\*2. Maximum pulse width = 50  $\mu\text{s}$ , Maximum duty cycle = 0.2 %.

\*3. Maximum pulse width = 10  $\mu\text{s}$ , Maximum duty cycle = 0.5 %.

\*4.  $V_{OH}$  is measured with the pulse load current in this testing (Maximum pulse width = 2 ms, Maximum duty cycle = 20 %).

**SWITCHING CHARACTERISTICS (at RECOMMENDED OPERATING CONDITIONS,  $V_{EE} = \text{GND}$ , unless otherwise specified)**

Parameter	Symbol	Conditions	MIN.	TYP.* 1	MAX.	Unit
Propagation Delay Time (L $\rightarrow$ H)	$t_{PLH}$	$R_g = 47 \text{ } \Omega$ , $C_g = 3 \text{ nF}$ , $f = 50 \text{ kHz}$ , Duty Cycle = 50 %, $I_F = 10 \text{ mA}$ , $V_{CC} = 30 \text{ V}$	50	100	150	ns
Propagation Delay Time (H $\rightarrow$ L)	$t_{PHL}$		50	90	150	ns
Pulse Width Distortion (PWD)	$ t_{PHL} - t_{PLH} $		5	50		ns
Propagation Delay Difference Between Any Two Parts (PDD)	$t_{PHL} - t_{PLH}$		-80		80	ns
Rise Time	$t_r$		6			ns
Fall Time	$t_f$		7			ns
Common Mode Transient Immunity at High Level Output	$ CM_H $	$V_{CC} = 30 \text{ V}$ , $I_F = 10 \text{ mA}$ , $T_A = 25 \text{ }^\circ\text{C}$ , $ V_{CM}  = 1.5 \text{ kV}$	50			$\text{kV}/\mu\text{s}$
Common Mode Transient Immunity at Low Level Output	$ CM_L $	$V_{CC} = 30 \text{ V}$ , $I_F = 0 \text{ mA}$ , $T_A = 25 \text{ }^\circ\text{C}$ , $ V_{CM}  = 1.5 \text{ kV}$	50			$\text{kV}/\mu\text{s}$

Notes: \*1. Typical values at  $T_A = 25 \text{ }^\circ\text{C}$ ,  $V_{CC} - V_{EE} = 30 \text{ V}$ .

TEST CIRCUIT

Fig. 1  $I_{OH}$  Test Circuit

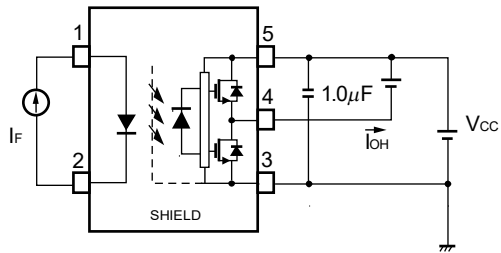

Fig. 2  $I_{OL}$  Test Circuit

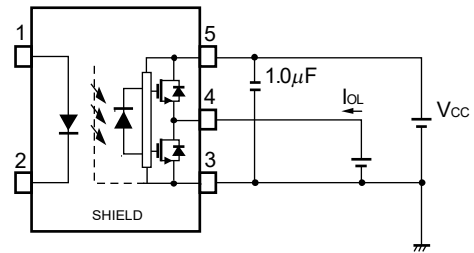

Fig. 3  $V_{OH}$  Test Circuit

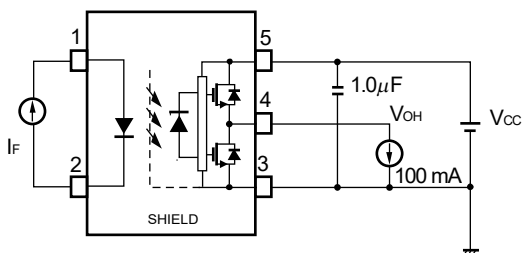

Fig. 4  $V_{OL}$  Test Circuit

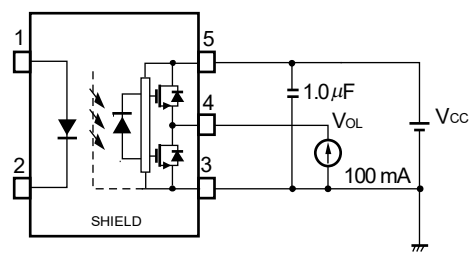

Fig. 5  $I_{CCH}/I_{CCL}$  Test Circuit

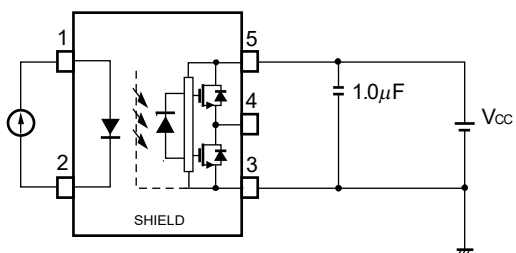

Fig. 6 UVLO Test Circuit

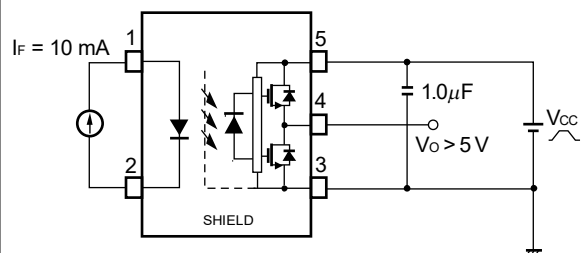

Fig. 7 I<sub>FLH</sub> Test Circuit

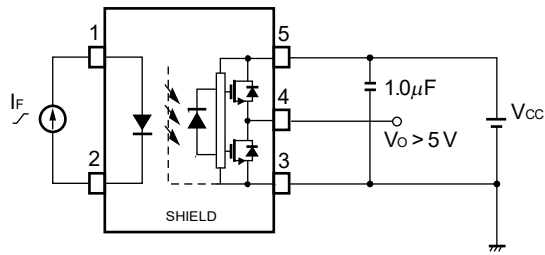

Fig. 8 t<sub>PLH</sub>, t<sub>PHL</sub>, t<sub>r</sub>, t<sub>f</sub> Test Circuit and Wave Forms

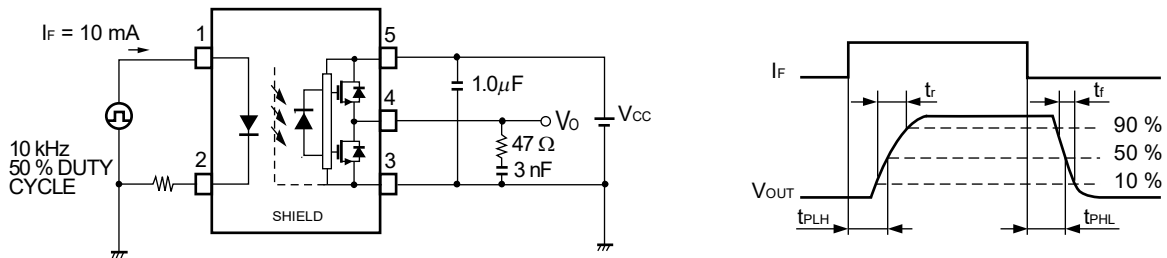
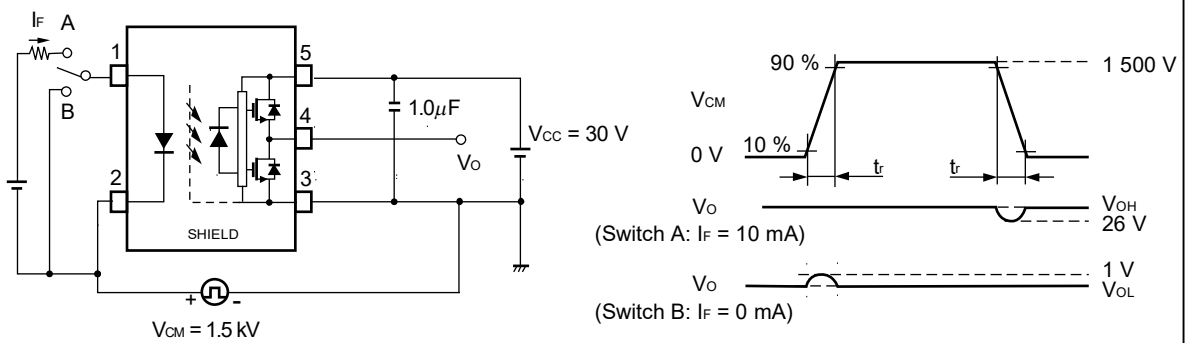
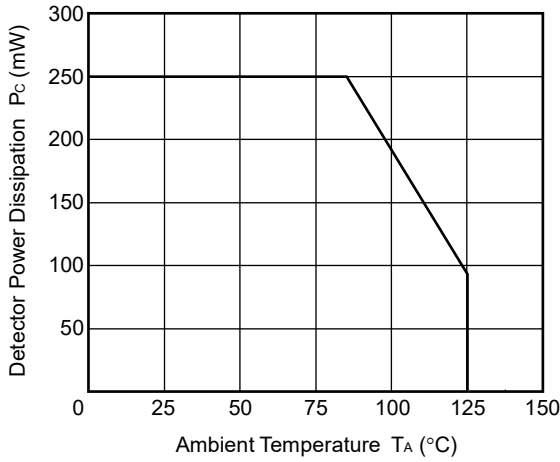

Fig. 9 CMR Test Circuit and Wave Forms



TYPICAL CHARACTERISTICS ( $T_A = 25\text{ }^\circ\text{C}$ , unless otherwise specified)

DETECTOR POWER DISSIPATION vs. AMBIENT TEMPERATURE



DIODE POWER DISSIPATION vs. AMBIENT TEMPERATURE

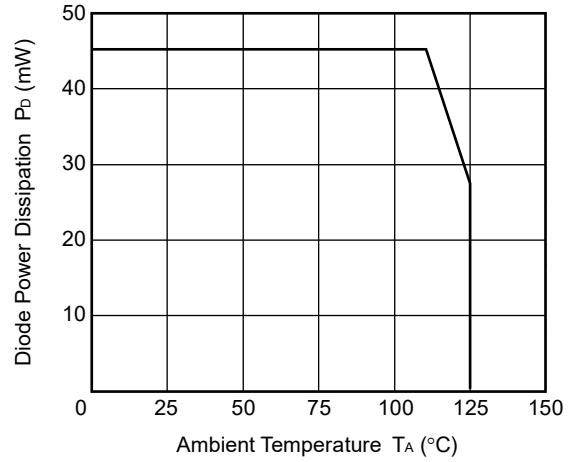

FORWARD CURRENT vs. FORWARD VOLTAGE

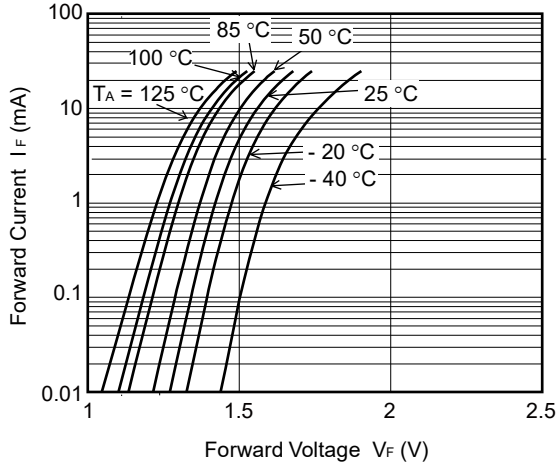

THRESHOLD INPUT CURRENT vs. AMBIENT TEMPERATURE

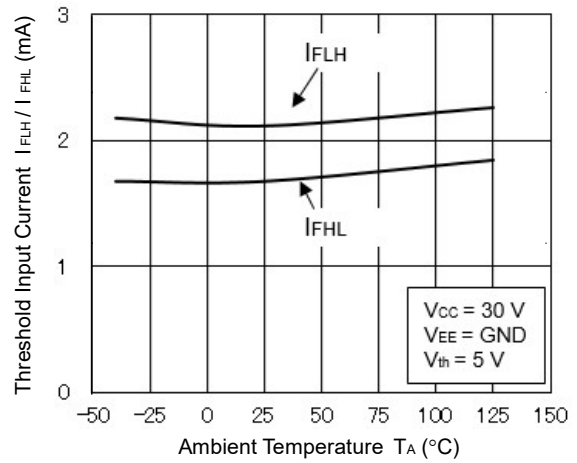

OUTPUT VOLTAGE vs. FORWARD CURRENT

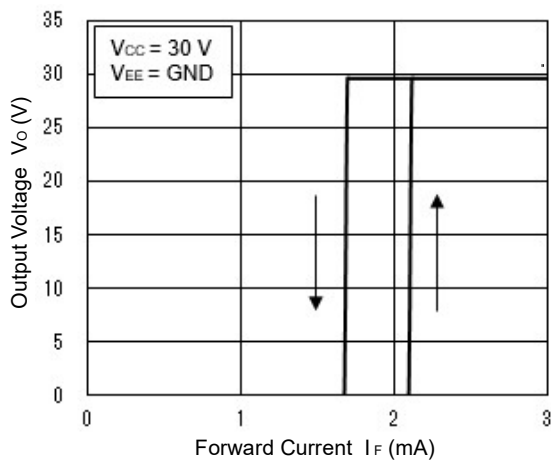

HIGH LEVEL OUTPUT CURRENT vs. HIGH LEVEL OUTPUT VOLTAGE – SUPPLY VOLTAGE

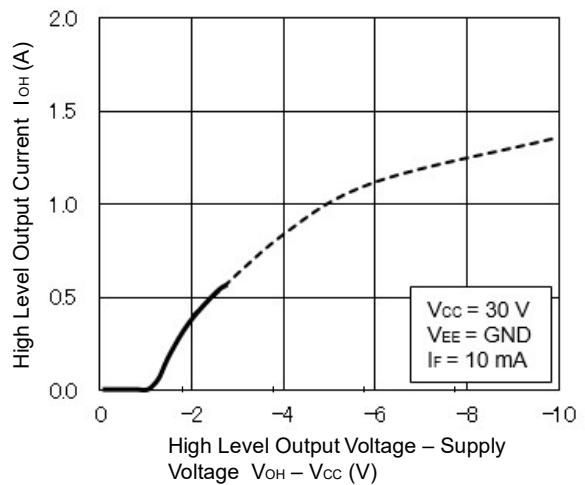

**Remark** The graphs indicate nominal characteristics.



TYPICAL CHARACTERISTICS (T<sub>A</sub> = 25 °C, unless otherwise specified)

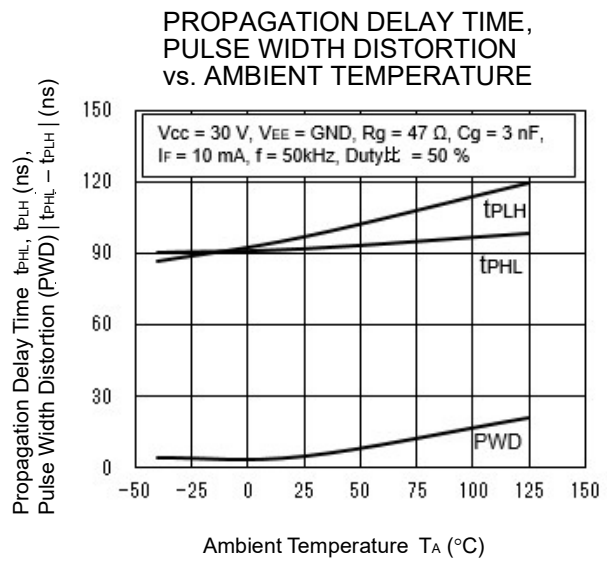
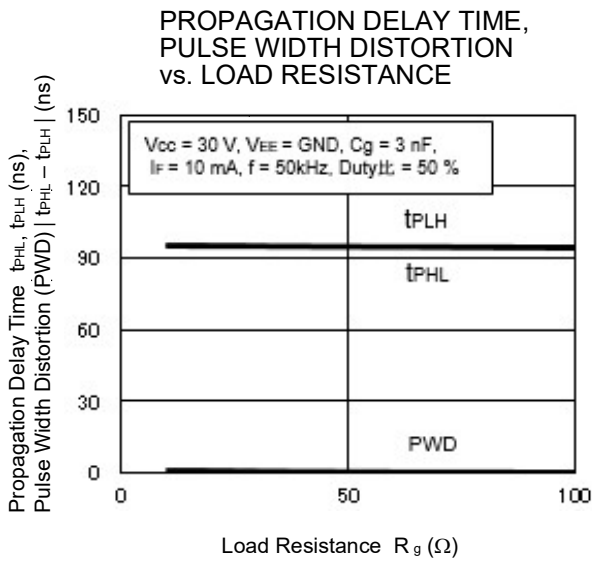
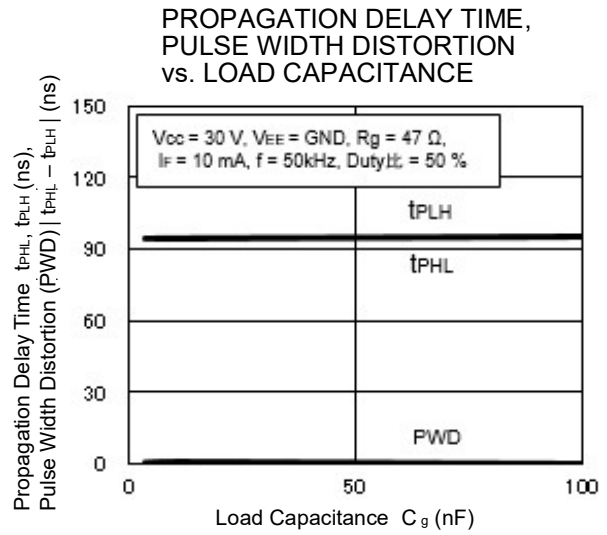
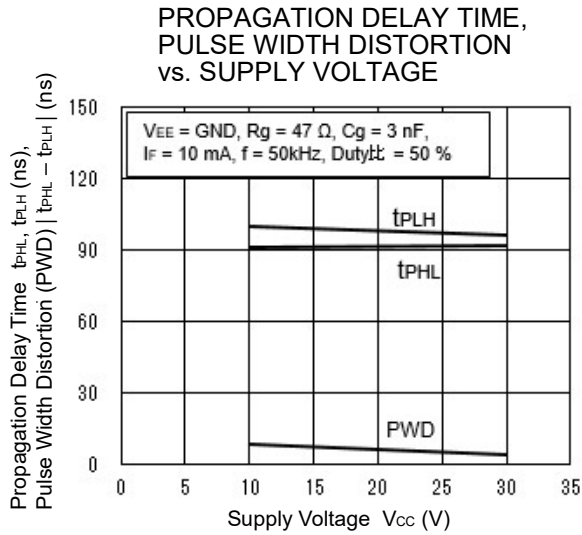
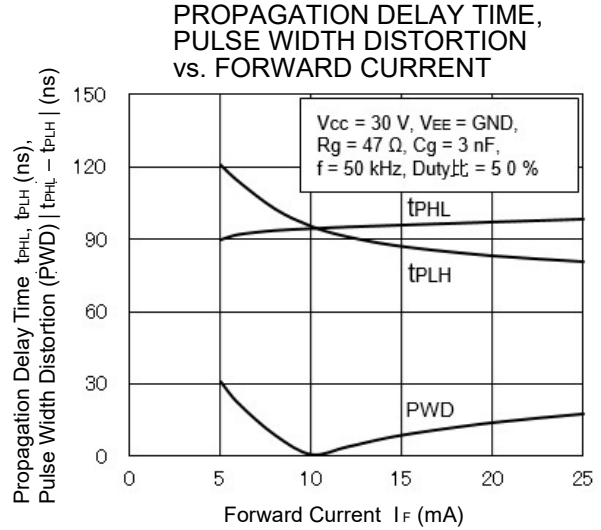
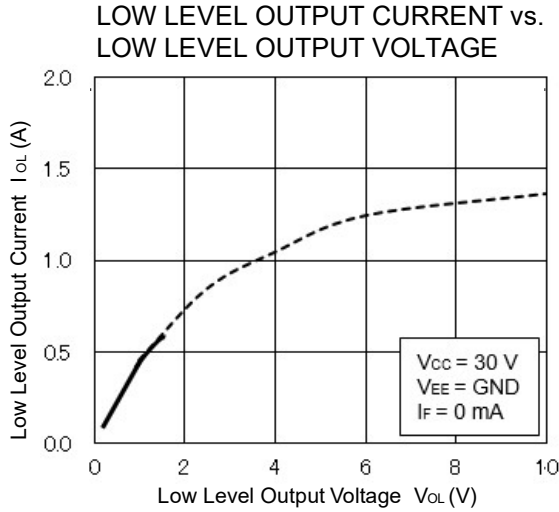

**Remark** The graphs indicate nominal characteristics.

TYPICAL CHARACTERISTICS (T<sub>A</sub> = 25 °C, unless otherwise specified)

SUPPLY CURRENT vs. AMBIENT TEMPERATURE

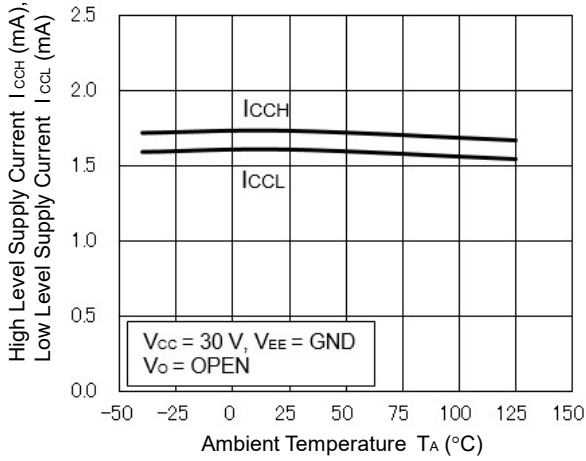

SUPPLY CURRENT vs. SUPPLY VOLTAGE

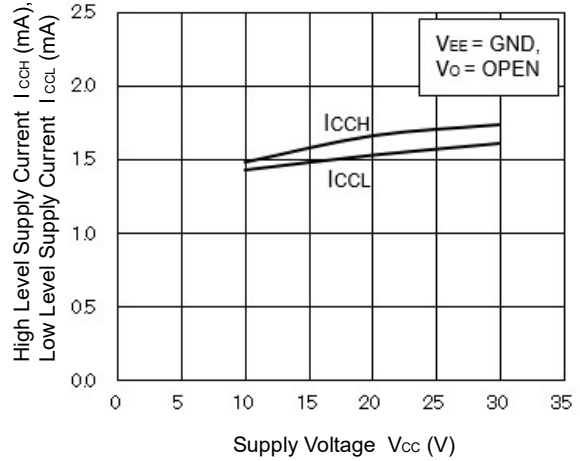

HIGH LEVEL OUTPUT VOLTAGE – SUPPLY VOLTAGE vs. AMBIENT TEMPERATURE

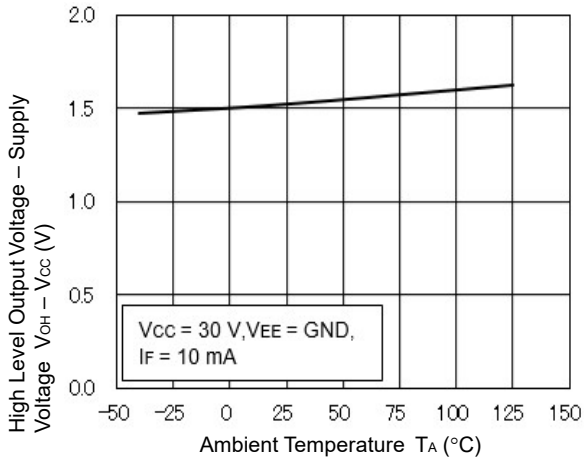

LOW LEVEL OUTPUT VOLTAGE vs. AMBIENT TEMPERATURE

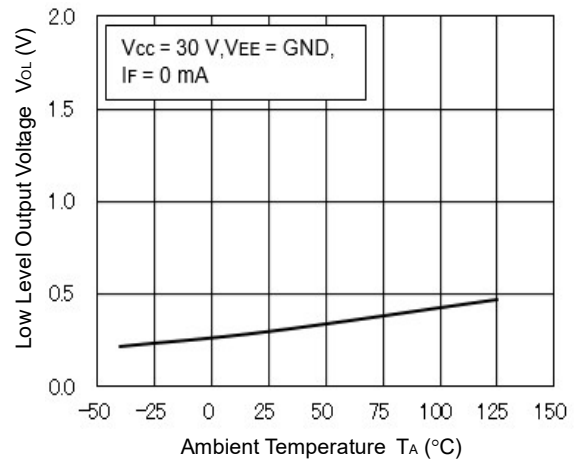

HIGH LEVEL OUTPUT CURRENT vs. AMBIENT TEMPERATURE

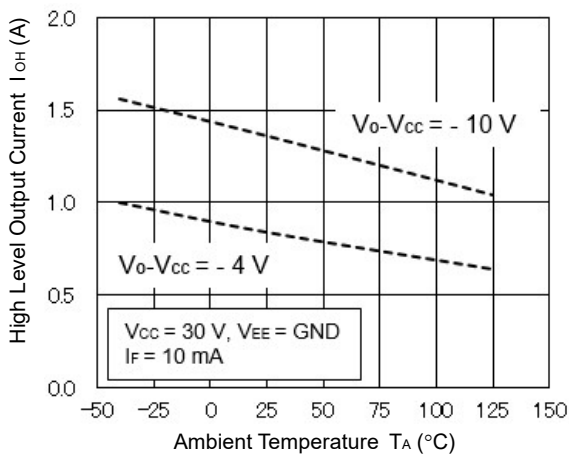

LOW LEVEL OUTPUT CURRENT vs. AMBIENT TEMPERATURE

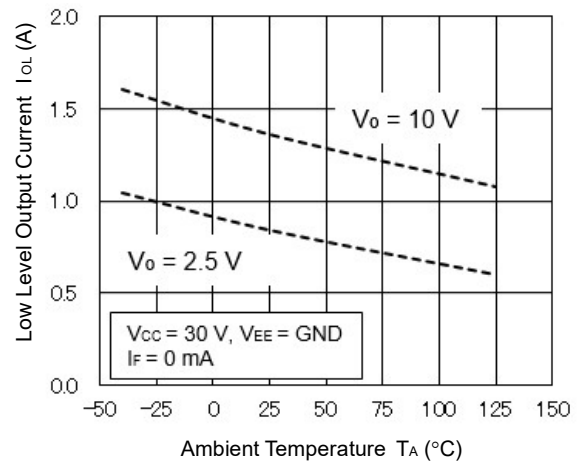

**Remark** The graphs indicate nominal characteristics.

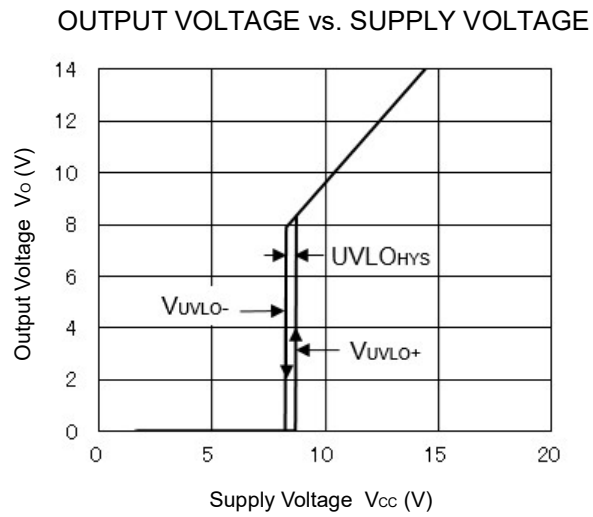
TYPICAL CHARACTERISTICS ( $T_A = 25\text{ }^\circ\text{C}$ , unless otherwise specified)

**Remark** The graphs indicate nominal characteristics.

TAPING SPECIFICATIONS (UNIT : mm)

Tape Direction

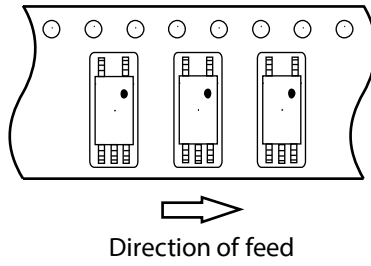

Outline and Dimensions (Tape)

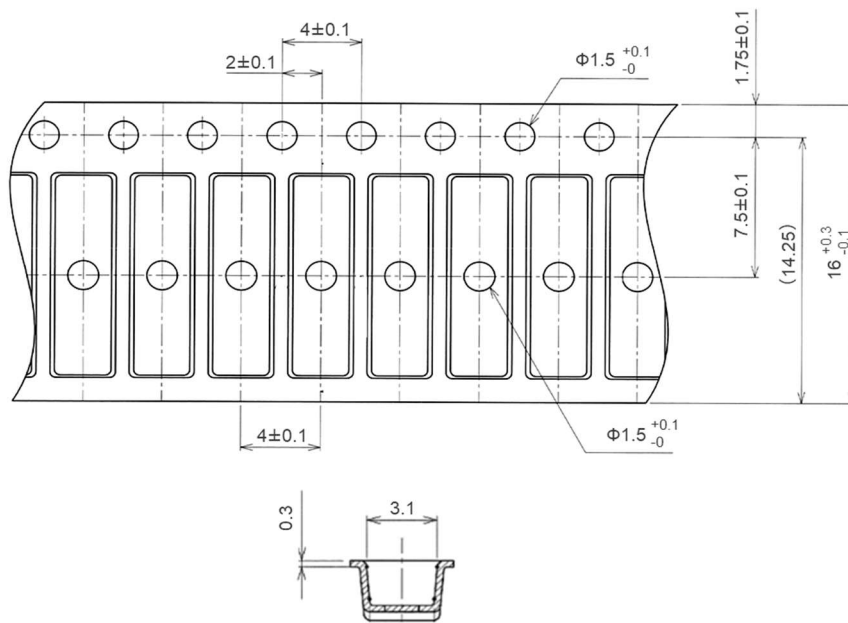

(Unit : mm)

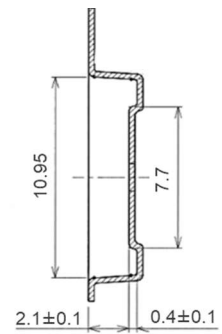

Outline and Dimensions (Reel)

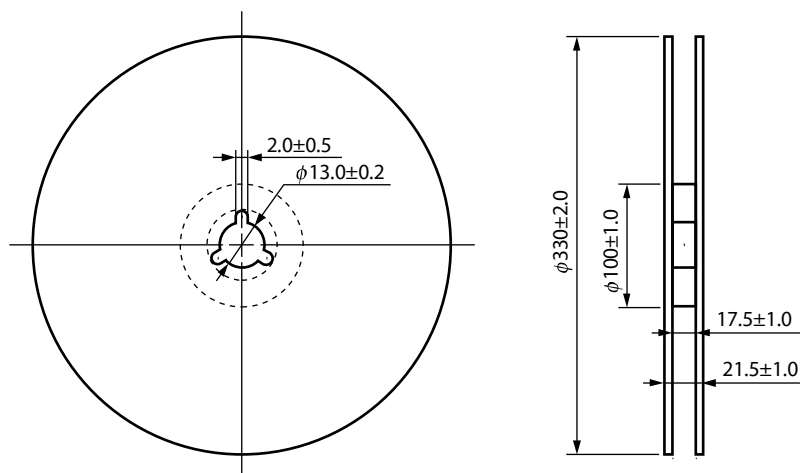

(Unit : mm)

Packing: 3 500 pcs/reel

## RECOMMENDED MOUNT PAD DIMENSIONS (UNIT : mm)

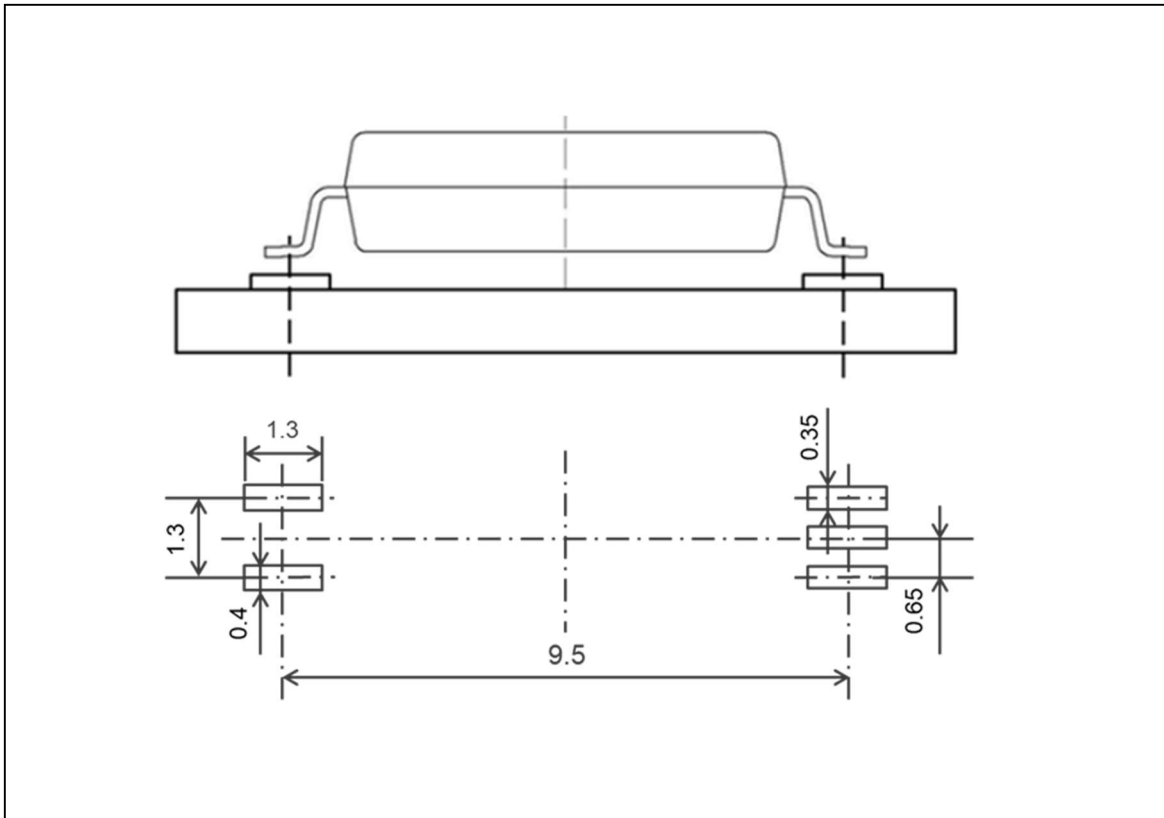

Remark All dimensions in this figure must be evaluated before use.

## NOTES ON HANDLING

## 1. Recommended soldering conditions

## (1) Infrared reflow soldering

- Peak reflow temperature 260°C or below (package surface temperature)
- Time of peak reflow temperature 10 seconds or less
- Time of temperature higher than 220°C 60 seconds or less
- Time to preheat temperature from 120 to 180°C 120±30 s
- Number of reflows Three
- Flux Rosin flux containing small amount of chlorine (The flux with a maximum chlorine content of 0.2 Wt% is recommended.)

Recommended Temperature Profile of Infrared Reflow

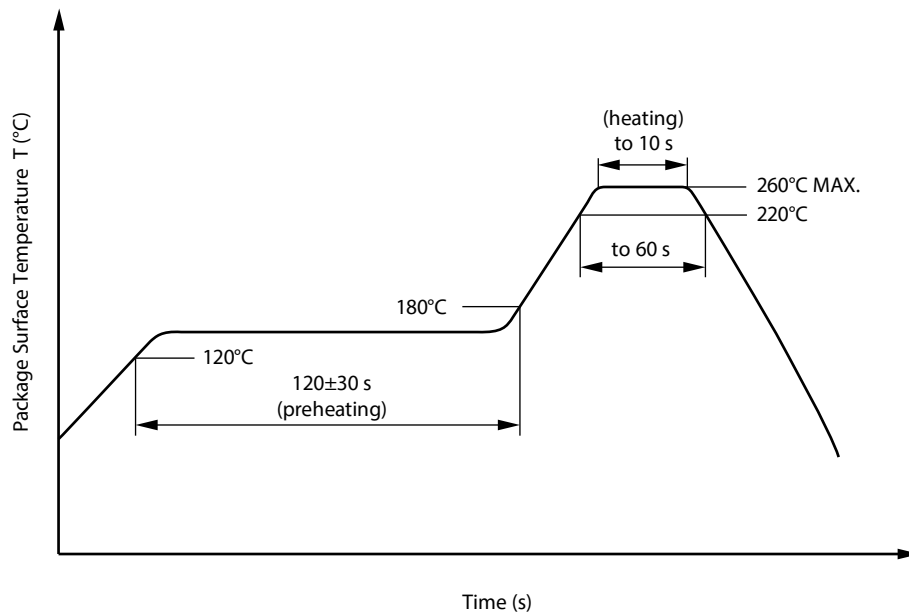

## (2) Wave soldering

- Temperature 260°C or below (molten solder temperature)
- Time 10 seconds or less
- Preheating conditions 120°C or below (package surface temperature)
- Number of times One (Allowed to be dipped in solder including plastic mold portion.)
- Flux Rosin flux containing small amount of chlorine (The flux with a maximum chlorine content of 0.2 Wt% is recommended.)

## (3) Soldering by Soldering Iron

- Peak Temperature (lead part temperature) 350°C or below
- Time (each pins) 3 seconds or less
- Flux Rosin flux containing small amount of chlorine  
(The flux with a maximum chlorine content of 0.2 Wt% is recommended.)

(a) Soldering of leads should be made at the point 1.5 to 2.0 mm from the root of the lead

(b) Please be sure that the temperature of the package would not be heated over 100°C

## (4) Cautions

- Flux Cleaning  
Avoid cleaning with Freon based or halogen-based (chlorinated etc.) solvents.
- Do not use fixing agents or coatings containing halogen-based substances.

## 2. Cautions regarding noise

Be aware that when voltage is applied suddenly between the photocoupler's input and output at startup, the output transistor may enter the on state, even if the voltage is within the absolute maximum ratings.

**USAGE CAUTIONS**

1. This product is weak for static electricity by designed with high-speed integrated circuit so protect against static electricity when handling.
2. Board designing
  - (1) By-pass capacitor of more than 1.0  $\mu$ F is used between  $V_{CC}$  and GND near device. Also, ensure that the distance between the leads of the photocoupler and capacitor is no more than 10 mm.
  - (2) When designing the printed wiring board, ensure that the pattern of the IGBT collectors/emitters is not too close to the input block pattern of the photocoupler.  
If the pattern is too close to the input block and coupling occurs, a sudden fluctuation in the voltage on the IGBT output side might affect the photocoupler's LED input, leading to malfunction or degradation of characteristics.  
(If the pattern needs to be close to the input block, to prevent the LED from lighting during the off state due to the abovementioned coupling, design the input-side circuit so that the bias of the LED is reversed, within the range of the recommended operating conditions, and be sure to thoroughly evaluate operation.)
3. Make sure the rise/fall time of the forward current is 0.5  $\mu$ s or less.
4. In order to avoid malfunctions, make sure the rise/fall slope of the supply voltage is 3 V/ $\mu$ s or less.
5. Avoid storage at a high temperature and high humidity.

## SPECIFICATION OF VDE MARKS LICENSE DOCUMENT

Parameter	Symbol	Rating	Unit
Climatic test class (IEC 60068-1/DIN EN 60068-1)		40/125/21	
Dielectric strength maximum operating isolation voltage	$U_{IORM}$	1 075	$V_{peak}$
Test voltage (partial discharge test, procedure a for type test and random test) $U_{pr} = 1.6 \times U_{IORM}, P_d < 5 \text{ pC}$	$U_{pr}$	1 720	$V_{peak}$
Test voltage (partial discharge test, procedure b for all devices) $U_{pr} = 1.875 \times U_{IORM}, P_d < 5 \text{ pC}$	$U_{pr}$	2 016	$V_{peak}$
Highest permissible overvoltage	$U_{IOTM}$	8 000	$V_{peak}$
Degree of pollution (IEC 60664-1/DIN EN 60664-1 (VDE 0110-1))		2	
Comparative tracking index (IEC 60112/DIN EN 60112 (VDE 0303-11))	CTI	400	
Material group (IEC 60664-1/DIN EN 60664-1 (VDE 0110-1))		II	
Storage temperature range	$T_{stg}$	-55~+150	°C
Operating temperature range	$T_A$	-40~+125	°C
Isolation resistance, minimum value $V_{IO} = 500 \text{ V dc at } T_A = 25^\circ\text{C}$ $V_{IO} = 500 \text{ V dc at } T_A \text{ MAX. at least } 100^\circ\text{C}$	Ris MIN. Ris MIN.	$10^{12}$ $10^{11}$	$\Omega$ $\Omega$
Safety maximum ratings (maximum permissible in case of fault, see thermal derating curve) Package temperature	$T_{si}$	175	°C
Current (input current $I_F$ , $P_{si} = 0$ )	$I_{si}$	400	mA
Power (output or total power dissipation)	$P_{si}$	700	mW
Isolation resistance $V_{IO} = 500 \text{ V dc at } T_A = T_{si}$	Ris MIN.	$10^9$	$\Omega$

## Dependence of maximum safety ratings with package temperature

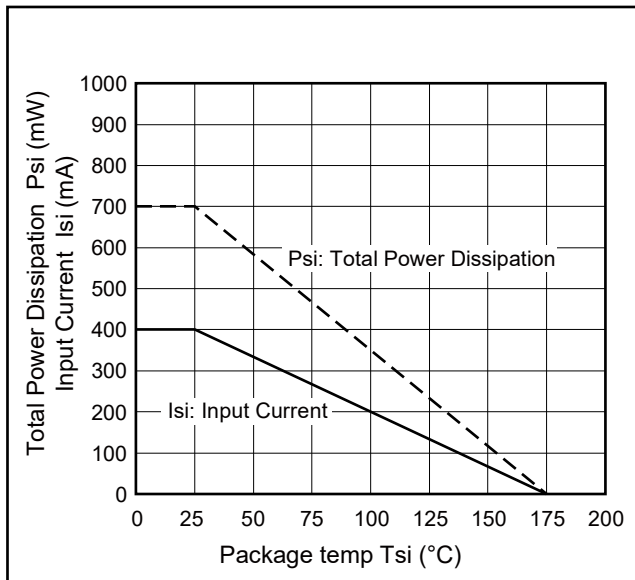



Method a) Destructive Test, Type and Sample Test

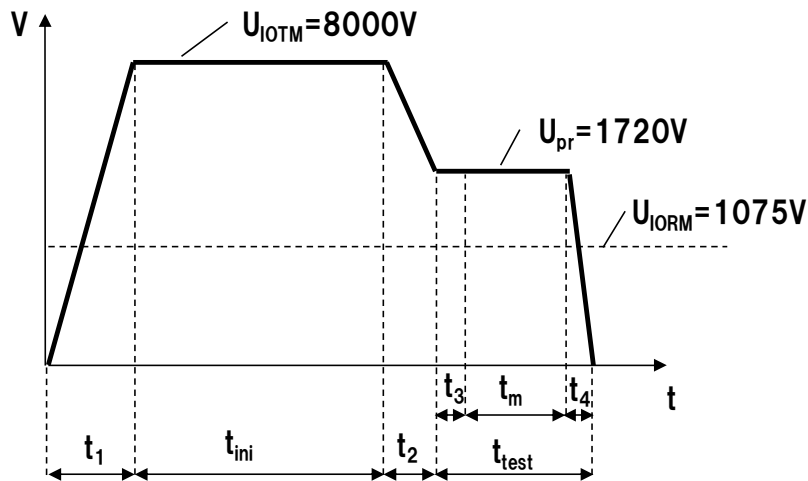

$t_1, t_2 = 1 \text{ to } 10 \text{ sec}$   
 $t_3, t_4 = 1 \text{ sec}$   
 $t_m \text{ (PARTIAL DISCHARGE)} = 10 \text{ sec}$   
 $t_{\text{test}} = 12 \text{ sec}$   
 $t_{\text{ini}} = 60 \text{ sec}$

Method b) Non-destructive Test, 100% Production Test

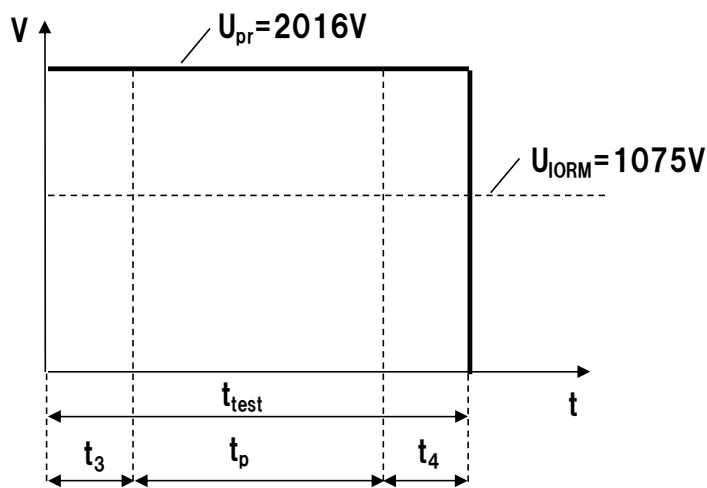

$t_3, t_4 = 0.1 \text{ sec}$   
 $t_p \text{ (PARTIAL DISCHARGE)} = 1.0 \text{ sec}$   
 $t_{\text{test}} = 1.2 \text{ sec}$

<b>Caution</b>	GaAs Products	<p>This product uses gallium arsenide (GaAs). GaAs vapor and powder are hazardous to human health if inhaled or ingested, so please observe the following points.</p> <ul style="list-style-type: none"><li>• Follow related laws and ordinances when disposing of the product. If there are no applicable laws and/or ordinances, dispose of the product as recommended below.<ol style="list-style-type: none"><li>1. Commission a disposal company able to (with a license to) collect, transport and dispose of materials that contain arsenic and other such industrial waste materials.</li><li>2. Exclude the product from general industrial waste and household garbage, and ensure that the product is controlled (as industrial waste subject to special control) up until final disposal.</li></ol></li><li>• Do not burn, destroy, cut, crush, or chemically dissolve the product.</li><li>• Do not lick the product or in any way allow it to enter the mouth.</li></ul>
----------------	---------------	--------------------------------------------------------------------------------------------------------------------------------------------------------------------------------------------------------------------------------------------------------------------------------------------------------------------------------------------------------------------------------------------------------------------------------------------------------------------------------------------------------------------------------------------------------------------------------------------------------------------------------------------------------------------------------------------------------------------------------------------------------------------------------------------------------------------------------------------------------------------------------------------------------------------------------------------------------------------------------------------

All trademarks and registered trademarks are the property of their respective owners.