

RV1S9209A

R08DS0218EJ0100

Rev.1.00

Mar 29,2021

LOW FORWARD-CURRENT(IF) TOTEM POLE OUTPUT TYPE HIGH CMR, IPM DRIVER,
5-PIN SSOP WITH 8.2mm CREEPAGE DISTANCE (LSSO5) PHOTOCOUPLER

DESCRIPTION

The RV1S9209A is an optical coupled high-speed, totem pole output (active high output type) isolator containing an AlGaAs LED on the input side and a photodiode and a signal processing circuit on the output side on one chip.

The RV1S9209A is specified high CMR and pulse width distortion with operating temperature. It is suitable for IPM (Intelligent Power Module) drive.

FEATURES

- Small and long creepage (8.2 mm MIN, LSSO5)
- Totem pole output (Active High Output Type)
- Pulse width distortion ($|t_{PLH} - t_{PHL}| = 80 \text{ ns MAX.}$)
- High common mode transient immunity ($CM_H, CM_L = \pm 50 \text{ kV}/\mu\text{s MIN.}$)
- Operating Ambient Temperature ($125 \text{ }^\circ\text{C MAX.}$)
- High isolation voltage ($BV = 5\,000 \text{ Vr.m.s.}$)
- Embossed tape product : RV1S9209ACCSP-10Yx#KC0 : 3 500 pcs/reel
- Pb-Free product
- Safety standard
 - UL : UL1577, Double protection
 - CSA : CAN/CSA-C22.2 No.62368-1, Reinforced insulation
 - VDE : DIN EN 60747-5-5 (Option)

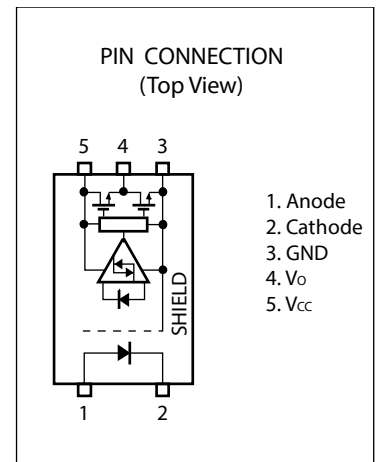

APPLICATIONS

- IPM Driver
- General purpose inverter

Start of mass production

Feb.2021

PACKAGE DIMENSIONS (UNIT : mm)

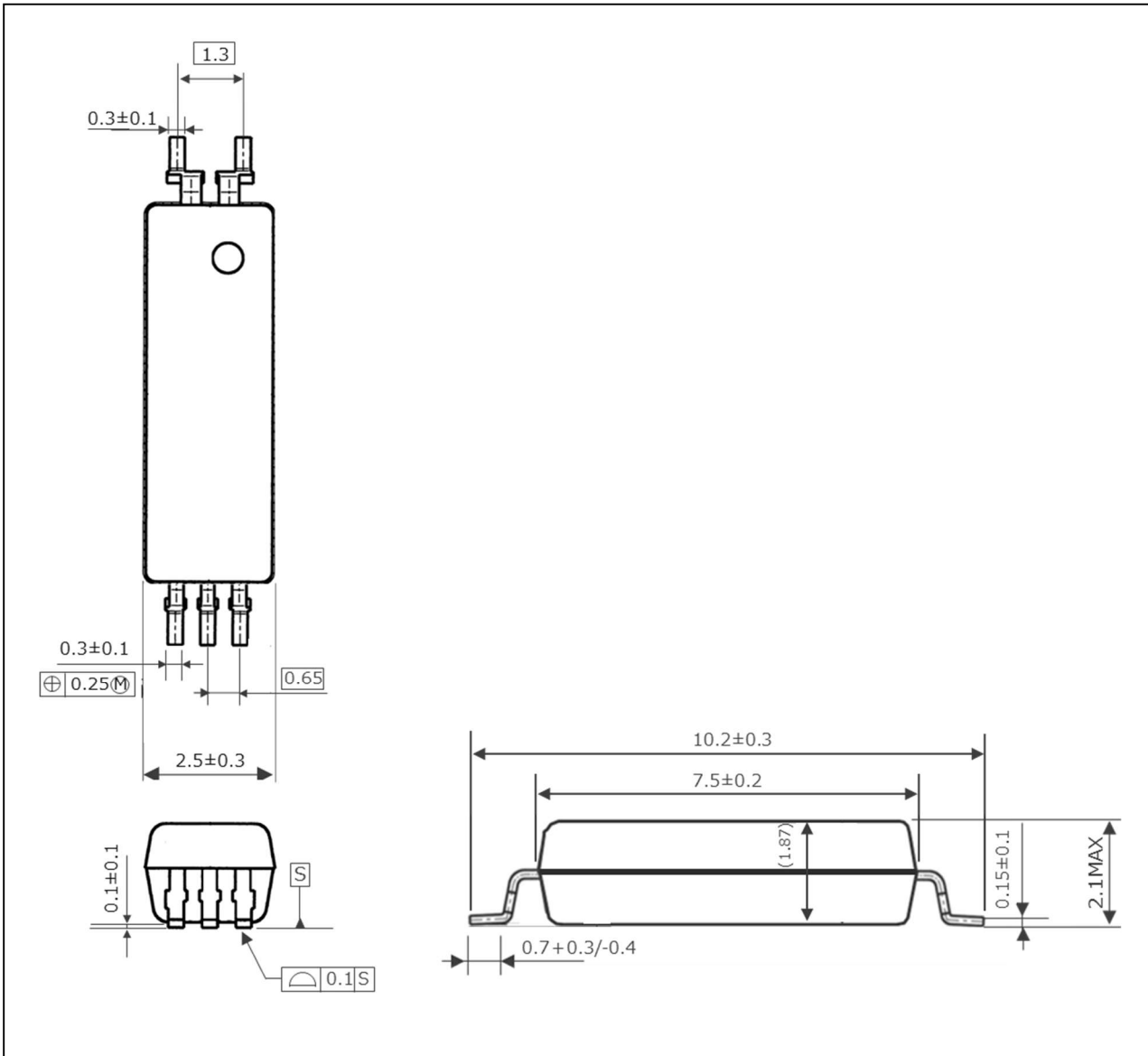

Weight :0.075g (Typ.)

PHOTOCOUPLER CONSTRUCTION

Parameter	MIN.
Air Distance	8.2 mm
Creepage Distance	8.2 mm
Isolation Distance	0.15 mm

BLOCK DIAGRAM

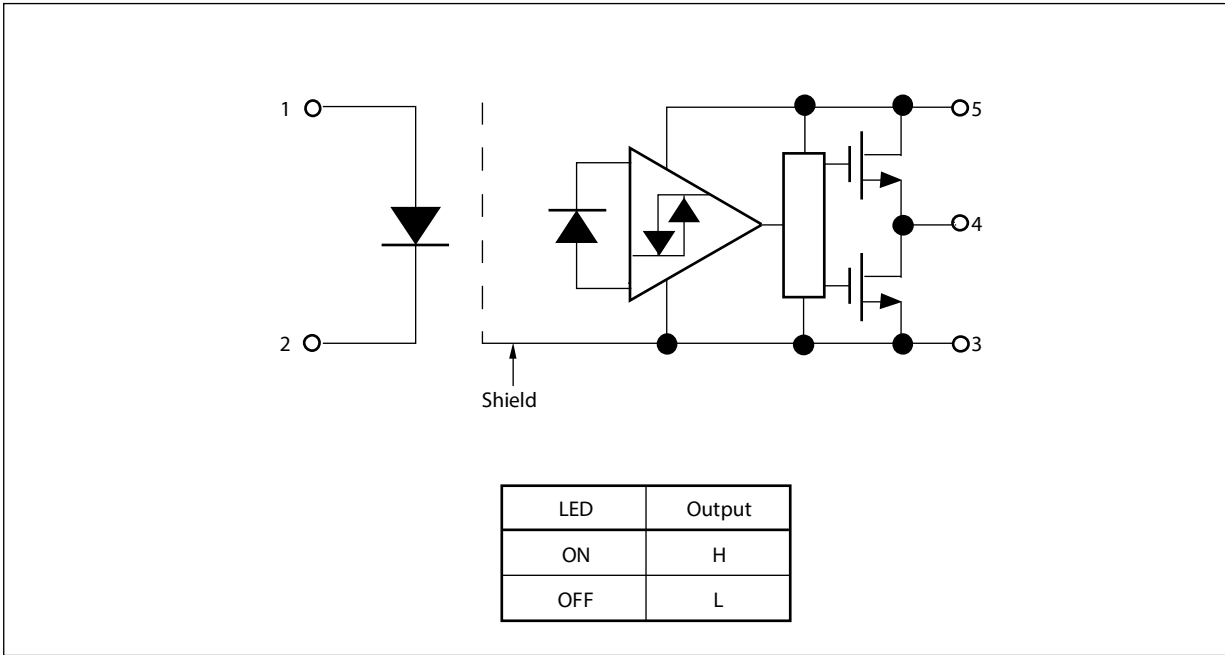

MARKING EXAMPLE

R	An initial of "Renesas"		
9209	Product Part Number *		
○	No.1 pin Mark		
N744	N	Rank Code	
	744	Assembly Lot	
		7	Last one-digit of Assembly Year
		44	Weekly Serial Code

*) Applicable type numbers listed below
 RV1S 9209 ACCSP-10Yx
 Marking type number. "RV1S" and "ACCSP-10Yx" are omitted from original type number.

ORDERING INFORMATION

Part Number	Order Number	Solder Plating Specification	Packing Style	Safety Standard Approval	Application Part Number*1
RV1S9209ACCSP -10YC	RV1S9209ACCSP -10YC#SC0	Pb-Free and Halogen Free (Ni/Pd/Au)	20 pcs (Tape 20 pcs cut)	Standard products (UL, CSA approved)	RV1S9209A
	RV1S9209ACCSP -10YC#KC0		Embossed Tape 3 500 pcs/reel		
RV1S9209ACCSP -10YV	RV1S9209ACCSP -10YV#SC0		20 pcs (Tape 20 pcs cut)	UL, CSA, DIN EN 60747-5-5 approved	
	RV1S9209ACCSP -10YV#KC0		Embossed Tape 3 500 pcs/reel		

Notes:*1. For the application of the Safety Standard, following part number should be used.

ABSOLUTE MAXIMUM RATINGS ($T_A = 25\text{ }^\circ\text{C}$, unless otherwise specified)

Parameter		Symbol	Ratings	Unit
Diode	Forward Current	I_F	20	mA
	Reverse Voltage	V_R	5	V
	Power Dissipation Derating	$\Delta P_D/^\circ\text{C}$	1.2 ($T_A \geq 110\text{ }^\circ\text{C}$)	mW/°C
	Power Dissipation	P_D	45	mW
Detector	Supply Voltage	V_{CC}	-0.5 to +25	V
	Output Voltage	V_O	-0.5 to +25	V
	Output Current	I_O	25	mA
	Power Dissipation Derating	$\Delta P_C/^\circ\text{C}$	4.0 ($T_A \geq 85\text{ }^\circ\text{C}$)	mW/°C
	Power Dissipation	P_C	250	mW
Isolation Voltage*1		BV	5 000	Vr.m.s.
Operating Ambient Temperature		T_A	-40 to +125	°C
Storage Temperature		T_{stg}	-55 to +150	°C

Notes: *1. AC voltage for 1 minute at $T_A = 25\text{ }^\circ\text{C}$, RH = 60 % between input and output.

Pins 1-2 shorted together, 3-5 shorted together.

RECOMMENDED OPERATING CONDITIONS

Parameter	Symbol	MIN.	TYP.	MAX.	Unit
Supply Voltage	V_{CC}	4.5	15	20	V
Forward Current (ON)	$I_{F(ON)}$	5		10	mA
Forward Voltage (OFF)	$V_{F(OFF)}$	0		0.8	V
Operating Ambient Temperature	T_A	-40		125	°C

ELECTRICAL CHARACTERISTICS

(T_A = - 40 to +125 °C, V_{CC} = 4.5 to 20 V, unless otherwise specified)

Parameter		Symbol	Conditions	MIN.	TYP.*1	MAX.	Unit
Diode	Forward Voltage	V _F	I _F = 10 mA, T _A = 25 °C	1.35	1.56	1.75	V
	Reverse Current	I _R	V _R = 3 V, T _A = 25 °C			10	μA
	Input Capacitance	C _i	V _F = 0 V, f = 1 MHz, T _A = 25 °C		30		pF
Detector	High Level Supply Current	I _{CC} H	V _{CC} = 4.5 V, I _F = 5 mA		1.0	3	mA
			V _{CC} = 20 V, I _F = 5 mA		1.6	3	
	Low Level Supply Current	I _{CC} L	V _{CC} = 4.5 V, I _F = 0 mA		1.2	3	mA
			V _{CC} = 20 V, I _F = 0 mA		1.8	3	
	High Level Output Voltage	V _{OH}	V _{CC} = 4.5 V, I _O = -2.6 mA, I _F = 5 mA	2.7	3.1		V
			V _{CC} = 20 V, I _O = -2.6 mA, I _F = 5 mA	17.4	18.6		
	Low Level Output Voltage *2	V _{OL}	I _O = 3.5 mA, I _F = 0 mA		0.25	0.6	V
	High Level Output Short *3 Circuit Current	I _{OSH}	V _{CC} = 4.5 V, V _O = GND, I _F = 5 mA	-7	-45		mA
Low Level Output Short *3 Circuit Current	I _{OSL}	V _{CC} = V _O = 4.5 V, V _F = 0 V	7	34		mA	
Coupled	Threshold Input Current	I _{FLH}	V _{CC} = 4.5 V, V _O > 2.7 V, I _O = -2.6 mA		1.6	3.8	mA
	Isolation Resistance	R _{I-O}	V _{I-O} = 1kVDC, RH = 60 %, T _A = 25 °C	10 ¹¹			Ω
	Isolation Capacitance	C _{I-O}	V = 0 V, f = 1MHz, T _A = 25 °C		0.6		pF
	Propagation Delay Time (H → L)*4	t _{PHL}	C _L = 15 pF, I _F = 5 → 0 mA, V _{THHL} = 1.3 V		108	200	ns
	Propagation Delay Time (L → H)*4	t _{PLH}	C _L = 15 pF, I _F = 0 → 5 mA, V _{THLH} = 1.3 V		121	200	
	Pulse Width Distortion (PWD)	t _{PLH} -t _{PHL}	C _L = 15 pF, I _F = 5 ↔ 0 mA		13	80	ns
	Propagation Delay Difference Between Any Two Parts (PDD)					100	
	Rise Time (10-90%)*4	t _r	C _L = 15 pF, I _F = 0 → 5 mA		25		ns
	Fall Time (90-10%)*4	t _f	C _L = 15 pF, I _F = 5 → 0 mA		5		
	Common Mode Transient Immunity at High Level Output*5	CM _H	V _{CC} = 5 V, T _A = 25 °C, I _F = 5 mA, V _{CM} = 1.5 kV	50			kV/μs
	Common Mode Transient Immunity at Low Level Output*5	CM _L	V _{CC} = 5 V, T _A = 25 °C, I _F = 0 mA, V _{CM} = 1.5 kV	50			

Notes: *1. Typical values at T_A = 25 °C

*2. Because V_O of 2.4 V may be output when the LED current is not input and when output supply of V_{CC} = 4.5 V or less, it is important to confirm the characteristics (operation with the power supply on and off) during design, before using this device.

*3. Duration of output short circuit time should not exceed 10 ms.

*4. Test circuit for propagation delay time

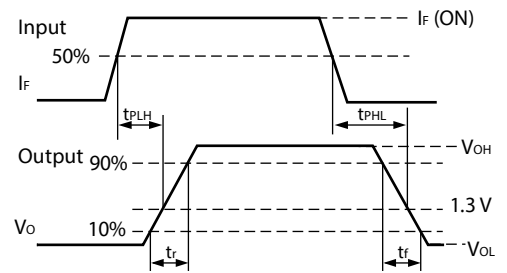
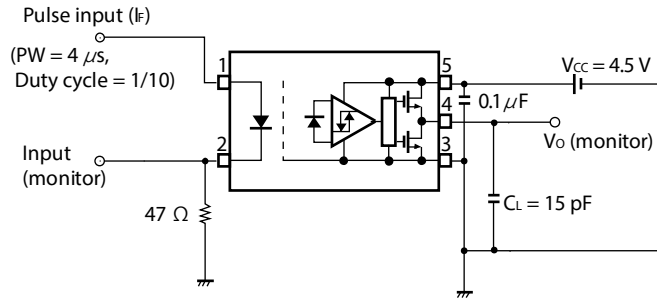

Remark CL includes probe and stray wiring capacitance.

*5. Test circuit for common mode transient immunity

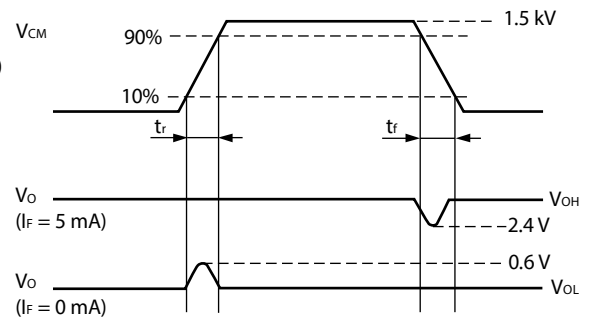
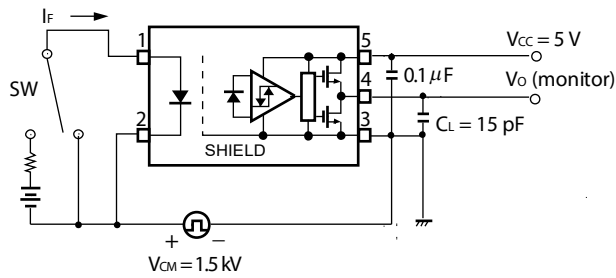

Remark CL includes probe and stray wiring capacitance.

TYPICAL CHARACTERISTICS ($T_A = 25\text{ }^\circ\text{C}$, unless otherwise specified)

DIODE POWER DISSIPATION vs. AMBIENT TEMPERATURE

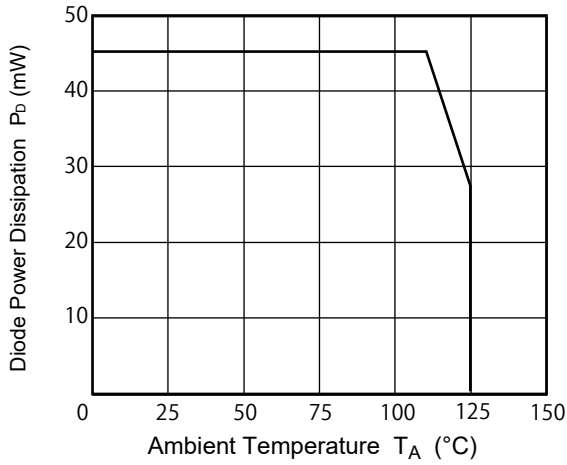

DETECTOR POWER DISSIPATION vs. AMBIENT TEMPERATURE

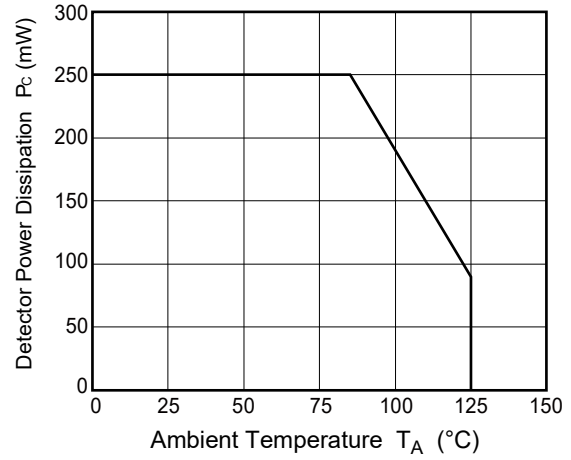

FORWARD CURRENT vs. FORWARD VOLTAGE

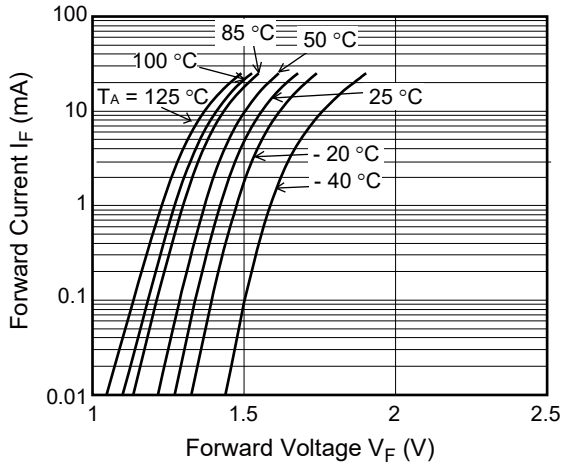

SUPPLY CURRENT vs. AMBIENT TEMPERATURE

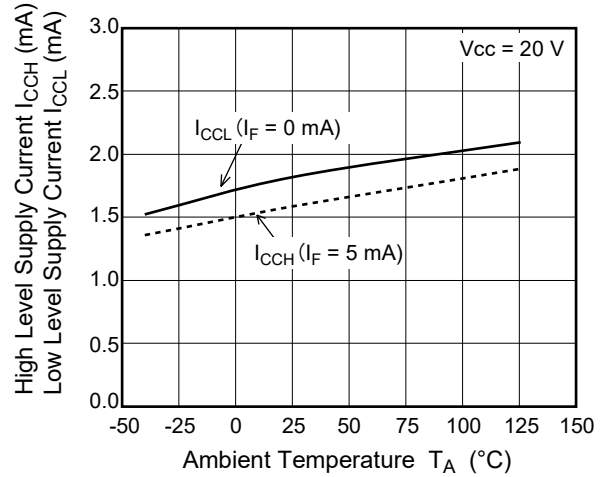

THRESHOLD INPUT CURRENT vs. AMBIENT TEMPERATURE

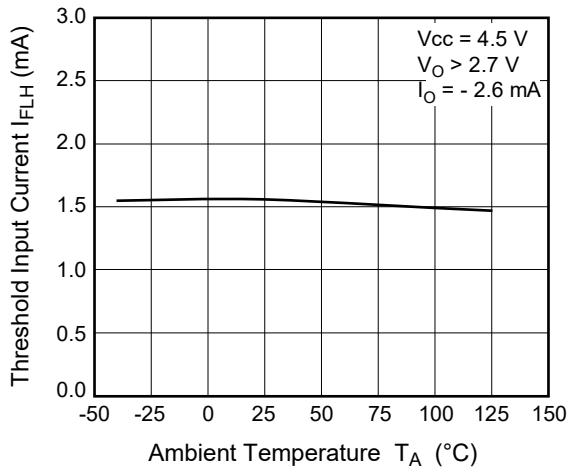

LOW LEVEL OUTPUT VOLTAGE vs. AMBIENT TEMPERATURE

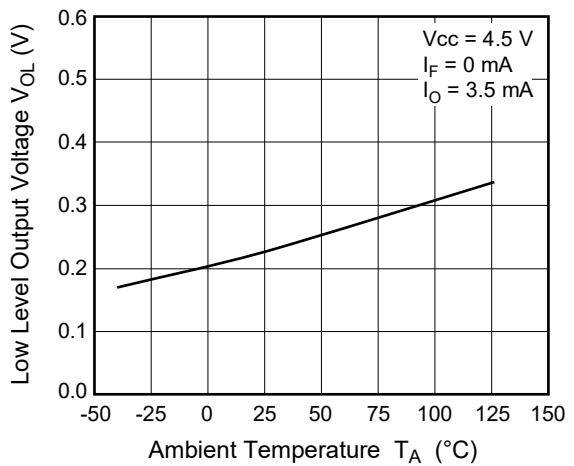

Remark The graphs indicate nominal characteristics.

TYPICAL CHARACTERISTICS ($T_A = 25\text{ }^\circ\text{C}$, unless otherwise specified)

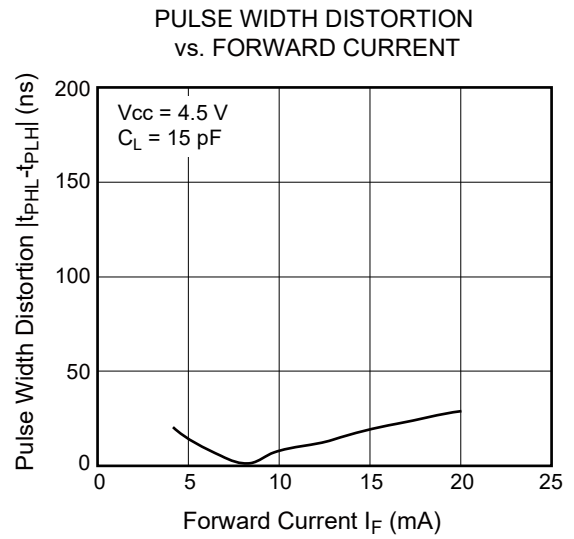
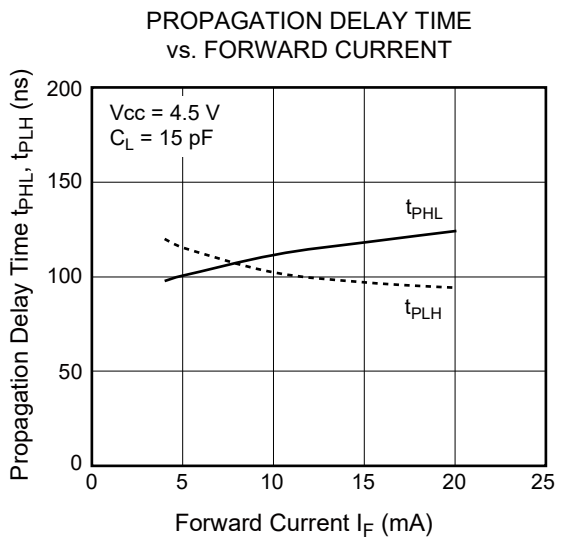
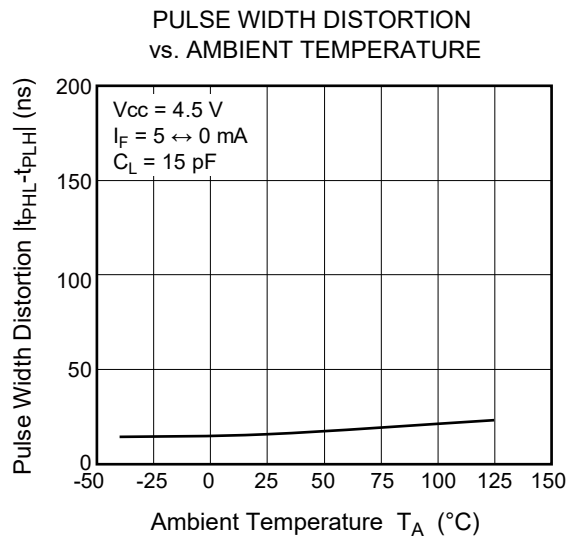
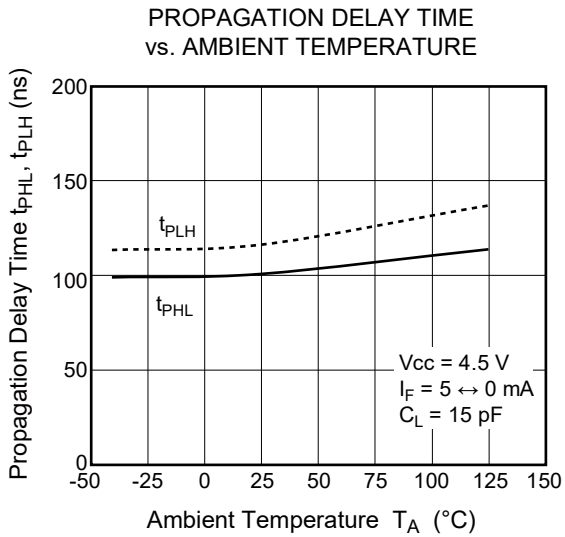
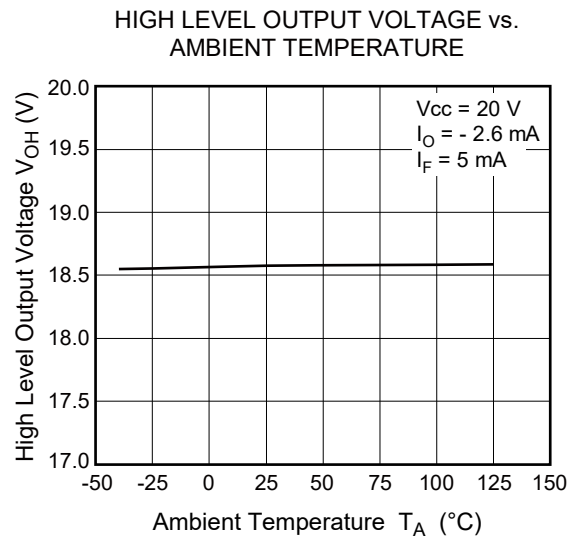
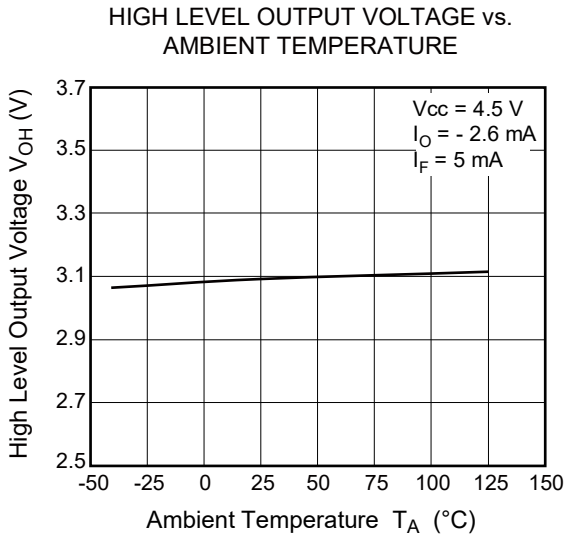

Remark The graphs indicate nominal characteristics.

TAPING SPECIFICATIONS (UNIT : mm)

Taping Direction

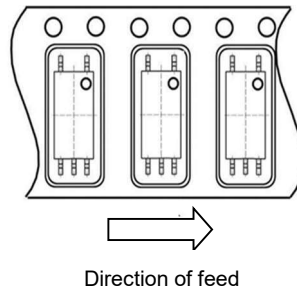

Outline and Dimensions (Tape)

Unit: mm

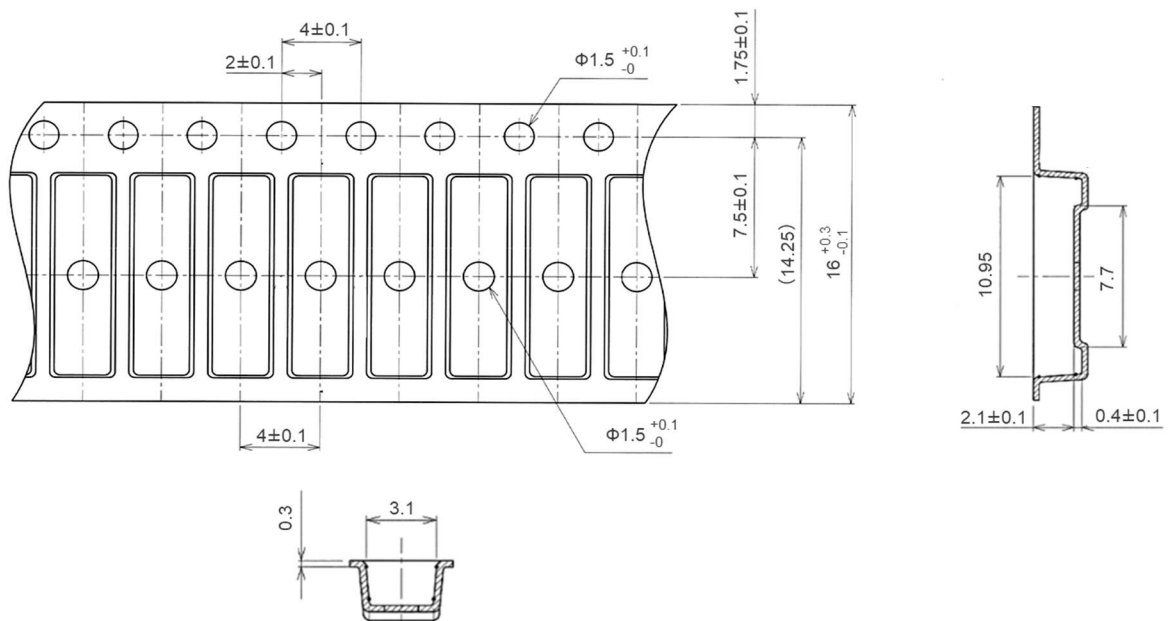

Outline and Dimensions (Reel)

Unit: mm

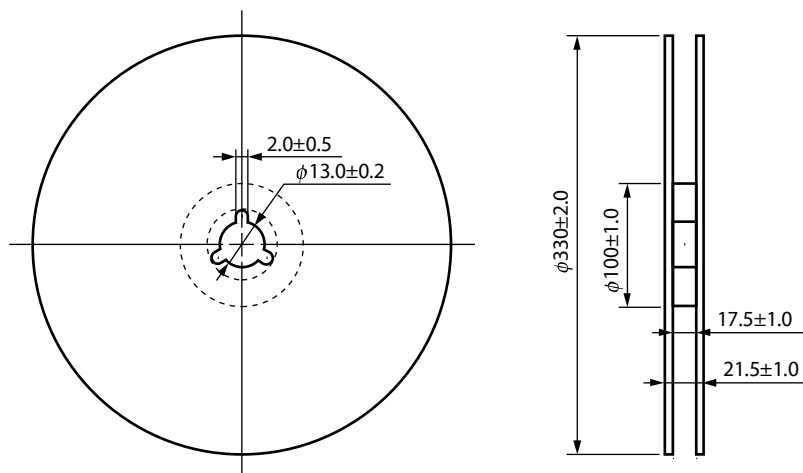

Packing: 3 500 pcs/reel

RECOMMENDED MOUNT PAD DIMENSIONS (UNIT : mm)

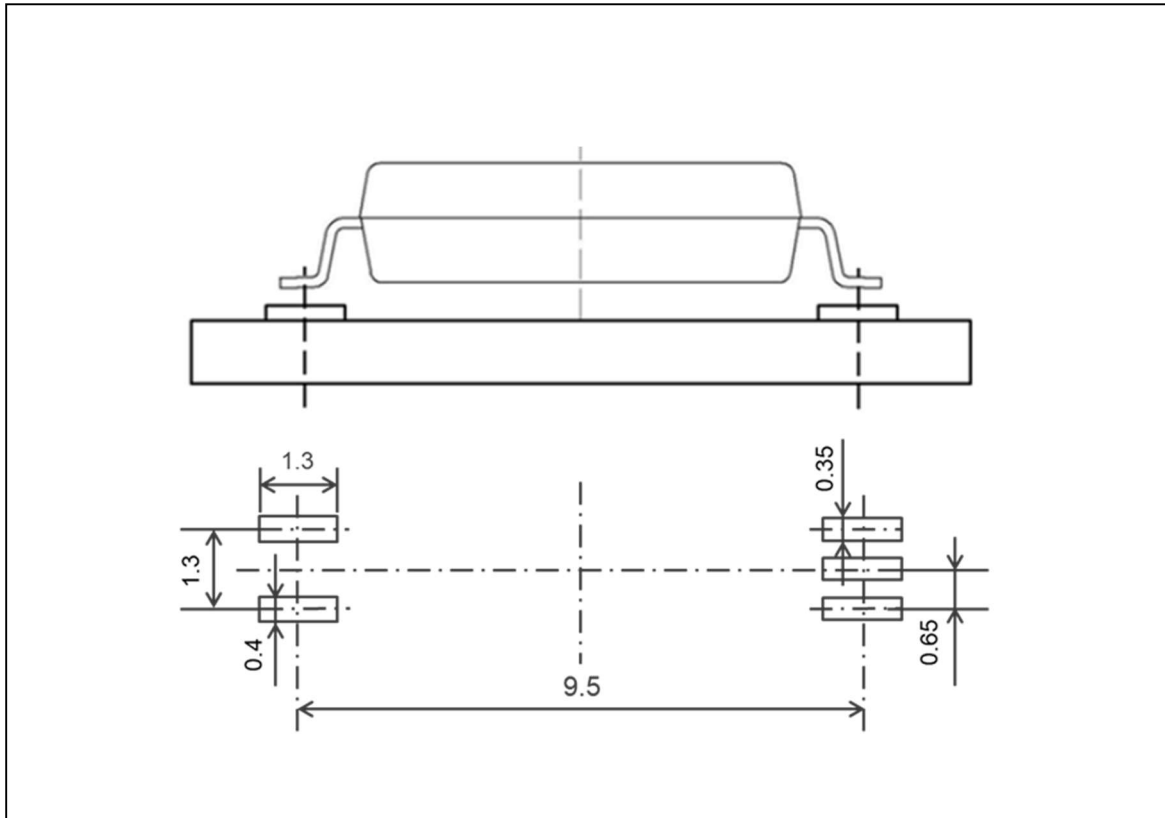

Remark All dimensions in this figure must be evaluated before use.

NOTES ON HANDLING

1. Recommended soldering conditions

(1) Infrared reflow soldering

- Peak reflow temperature 260°C or below (package surface temperature)
- Time of peak reflow temperature 10 seconds or less
- Time of temperature higher than 220°C 60 seconds or less
- Time to preheat temperature from 120 to 180°C 120±30 s
- Number of reflows Three
- Flux Rosin flux containing small amount of chlorine (The flux with a maximum chlorine content of 0.2 Wt% is recommended.)

Recommended Temperature Profile of Infrared Reflow

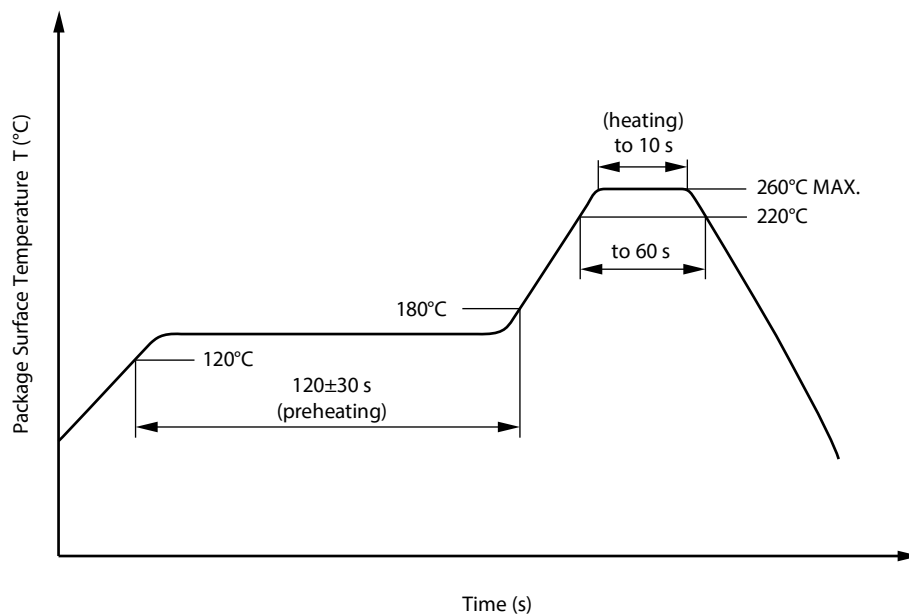

(2) Wave soldering

- Temperature 260°C or below (molten solder temperature)
- Time 10 seconds or less
- Preheating conditions 120°C or below (package surface temperature)
- Number of times One (Allowed to be dipped in solder including plastic mold portion.)
- Flux Rosin flux containing small amount of chlorine (The flux with a maximum chlorine content of 0.2 Wt% is recommended.)

(3) Soldering by Soldering Iron

- Peak Temperature (lead part temperature) 350°C or below
- Time (each pins) 3 seconds or less
- Flux Rosin flux containing small amount of chlorine
(The flux with a maximum chlorine content of 0.2 Wt% is recommended.)

(a) Soldering of leads should be made at the point 1.5 to 2.0 mm from the root of the lead

(b) Please be sure that the temperature of the package would not be heated over 100°C

(4) Cautions

- Flux Cleaning
Avoid cleaning with Freon based or halogen-based (chlorinated etc.) solvents.
- Do not use fixing agents or coatings containing halogen-based substances.

2. Cautions regarding noise

Be aware that when voltage is applied suddenly between the photocoupler's input and output at startup, the output transistor may enter the on state, even if the voltage is within the absolute maximum ratings.

USAGE CAUTIONS

1. This product is weak for static electricity by designed with high-speed integrated circuit so protect against static electricity when handling.
2. By-pass capacitor of more than 0.1 μF is used between V_{CC} and GND near device. Also, ensure that the distance between the leads of the photocoupler and capacitor is no more than 10 mm.
3. Avoid storage at a high temperature and high humidity.

SPECIFICATION OF VDE MARKS LICENSE DOCUMENT

Parameter	Symbol	Rating	Unit
Climatic test class (IEC 60068-1/DIN EN 60068-1)		40/125/21	
Dielectric strength maximum operating isolation voltage Test voltage (partial discharge test, procedure a for type test and random test) $U_{pr} = 1.6 \times U_{IORM}, P_d < 5 \text{ pC}$	U_{IORM} U_{pr}	1 075 1 720	V_{peak} V_{peak}
Test voltage (partial discharge test, procedure b for all devices) $U_{pr} = 1.875 \times U_{IORM}, P_d < 5 \text{ pC}$	U_{pr}	2 016	V_{peak}
Highest permissible overvoltage	U_{IOTM}	8 000	V_{peak}
Degree of pollution (IEC 60664-1/DIN EN 60664-1 (VDE 0110-1))		2	
Comparative tracking index (IEC 60112/DIN EN 60112 (VDE 0303-11))	CTI	400	
Material group (IEC 60664-1/DIN EN 60664-1 (VDE 0110-1))		II	
Storage temperature range	T_{stg}	-55~+150	°C
Operating temperature range	T_A	-40~+125	°C
Isolation resistance, minimum value $V_{IO} = 500 \text{ V dc at } T_A = 25^\circ\text{C}$ $V_{IO} = 500 \text{ V dc at } T_A \text{ MAX. at least } 100^\circ\text{C}$	Ris MIN. Ris MIN.	10^{12} 10^{11}	Ω Ω
Safety maximum ratings (maximum permissible in case of fault, see thermal derating curve) Package temperature Current (input current I_F , $\Psi_i = 0$) Power (output or total power dissipation) Isolation resistance $V_{IO} = 500 \text{ V dc at } T_A = T_{si}$	T_{si} I_{si} Ψ_{si} Ris MIN.	175 400 700 10^9	°C mA mW Ω

Dependence of maximum safety ratings with package temperature

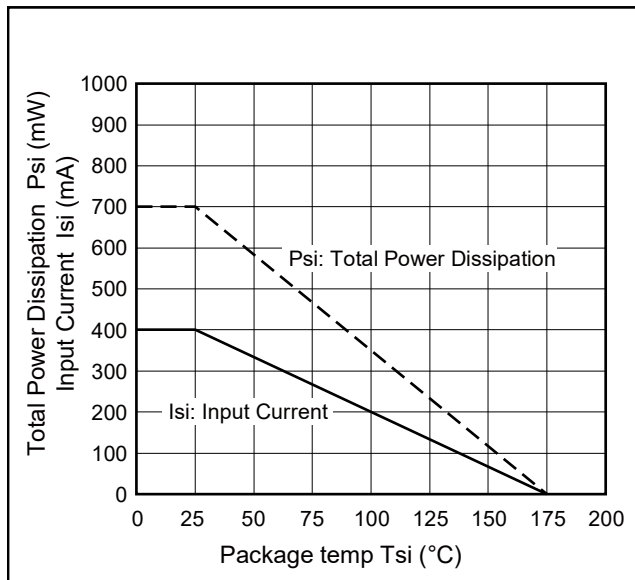

Method a) Destructive Test, Type and Sample Test

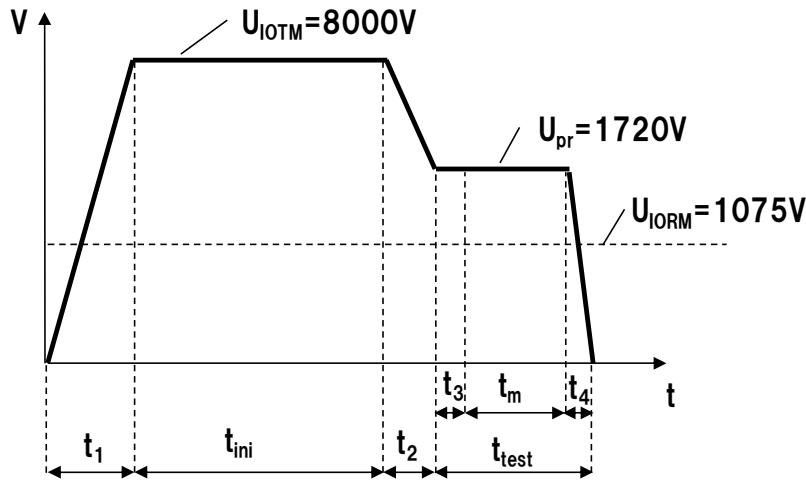

- $t_1, t_2 = 1$ to 10 sec
- $t_3, t_4 = 1$ sec
- t_m (PARTIAL DISCHARGE) = 10 sec
- $t_{test} = 12$ sec
- $t_{ini} = 60$ sec

Method b) Non-destructive Test, 100% Production Test

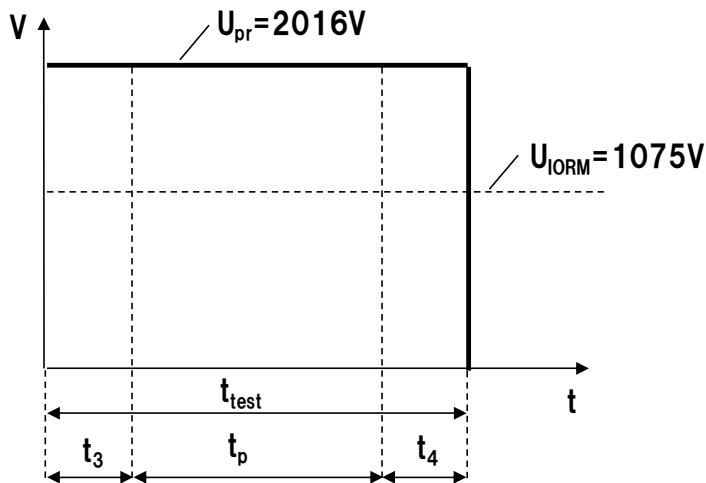

- $t_3, t_4 = 0.1$ sec
- t_p (PARTIAL DISCHARGE) = 1.0 sec
- $t_{test} = 1.2$ sec

Caution	GaAs Products	<p>This product uses gallium arsenide (GaAs). GaAs vapor and powder are hazardous to human health if inhaled or ingested, so please observe the following points.</p> <ul style="list-style-type: none">• Follow related laws and ordinances when disposing of the product. If there are no applicable laws and/or ordinances, dispose of the product as recommended below.<ol style="list-style-type: none">1. Commission a disposal company able to (with a license to) collect, transport and dispose of materials that contain arsenic and other such industrial waste materials.2. Exclude the product from general industrial waste and household garbage, and ensure that the product is controlled (as industrial waste subject to special control) up until final disposal.• Do not burn, destroy, cut, crush, or chemically dissolve the product.• Do not lick the product or in any way allow it to enter the mouth.
----------------	---------------	--

All trademarks and registered trademarks are the property of their respective owners.