

RV1S9213A

R08DS0187EJ0100

Rev.1.00

Nov 11,2019

1 Mbps, OPEN COLLECTOR OUTPUT, HIGH CMR, IPM DRIVER,
5-PIN SSOP WITH 8.2mm CREEPAGE DISTANCE (LSSO5) PHOTOCOUPLER

DESCRIPTION

The RV1S9213A is an optically coupled isolator containing an AlGaAs LED on the input side and a photo diode and a signal processing circuit on the output side on one chip. The RV1S9213A is designed specifically for high common mode transient immunity (CMR) and low pulse width distortion with operating temperature. It is suitable for IPM drive. This package is very small and thin with long creepage distance(8.2mm).

This small product is suitable for various interface circuits which require surface mounting and high-density mounting.

FEATURES

- Small and long creepage (8.2 mm, LSSO5)
- Open collector output
- High speed switching ($t_{PHL} = 500\text{ns MAX.}$, $t_{PLH} = 750\text{ns MAX.}$)
- Propagation Delay Difference ($t_{PLH} - t_{PHL} = 270\text{ ns TYP.}$)
- Operating temperature (-40 ~ +125°C)
- High common mode transient immunity ($CM_H, CM_L = \pm 50\text{ kV}/\mu\text{s MIN.}$)
- High isolation voltage ($BV = 5000\text{ Vr.m.s.}$)
- Embossed tape product : RV1S9213ACCSP-10Yx#KC0: 3500 pcs/reel
- Pb-Free product
- Safety standard
 - UL : UL1577, Double protection
 - CSA : CAN/CSA-C22.2 No.62368-1, Reinforced insulation
 - VDE : DIN EN 60747-5-5 (Option)

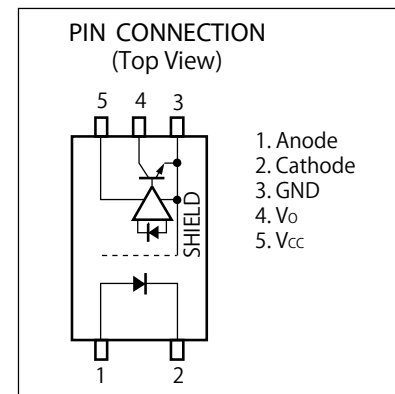

APPLICATIONS

- Robot controller
- Industrial inverter
- AC Servo
- FA Network
- Measurement equipment

Start of mass production

Nov.2019

PACKAGE DIMENSIONS (UNIT : mm)

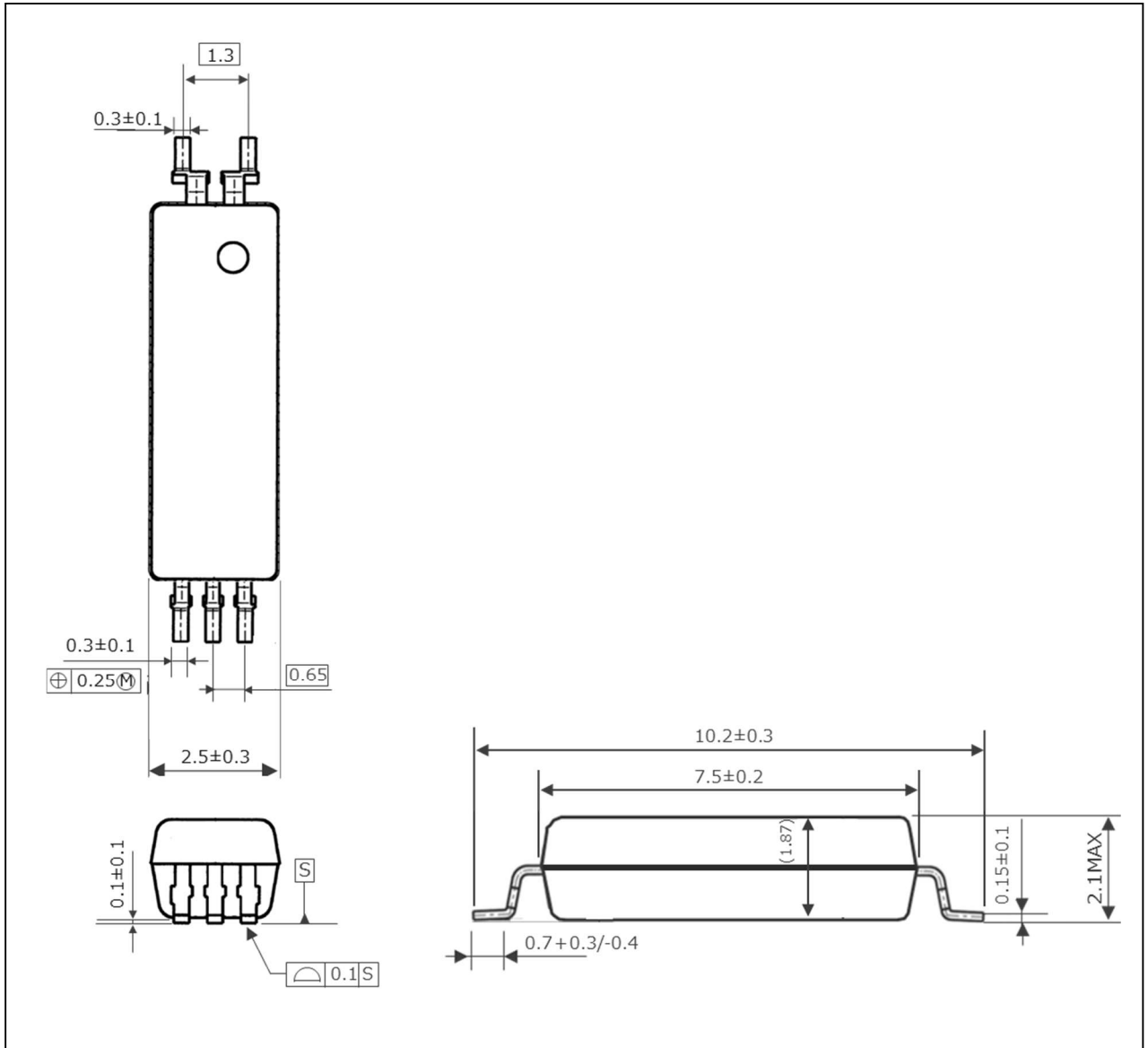

Weight :0.075g (Typ.)

PHOTOCOUPLER CONSTRUCTION

Parameter	MIN.
Air Distance	8.2 mm
Creepage Distance	8.2 mm
Isolation Distance	0.15 mm

BLOCK DIAGRAM

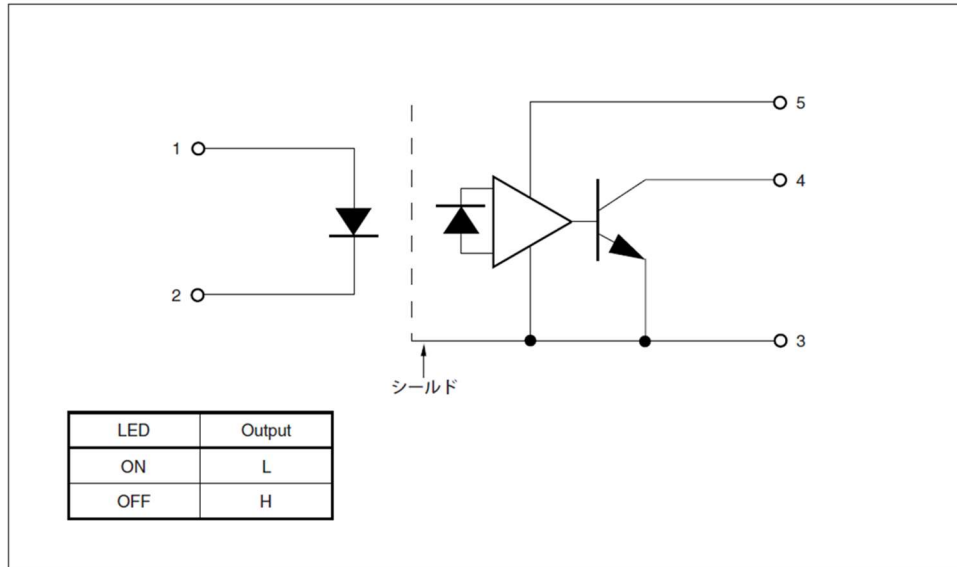

MARKING EXAMPLE

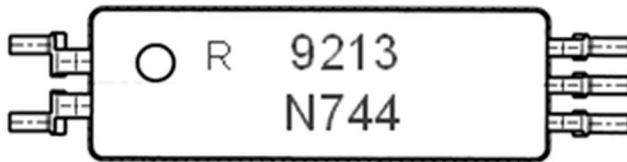

R	An initial of "Renesas"		
9213	Product Part Number *		
○	No.1 pin Mark		
N744	N	Rank Code	
	744	Assembly Lot	
		7	Last one-digit of Assembly Year
		44	Weekly Serial Code

*) Applicable type numbers listed below

RV1S 9213 ACCSP-10Yx

Marking type number. "RV1S" and "ACCSP-10Yx" are omitted from original type number

ORDERING INFORMATION

Part Number	Order Number	Solder Plating Specification	Packing Style	Safety Standard Approval	Application Part Number*1
RV1S9213ACCSP-10YC	RV1S9213ACCSP-10YC#SC0	Pb-Free and Halogen Free (Ni/Pd/Au)	20 pcs(Tape 20 pcs cut)	Standard products (UL, CSA approved)	RV1S9213A
	RV1S9213ACCSP-10YC#KC0		Embossed Tape 3500 pcs/reel		
RV1S9213ACCSP-10YV	RV1S9213ACCSP-10YV#SC0		20 pcs(Tape 20 pcs cut)	UL, CSA, DIN EN 60747-5-5 approved	
	RV1S9213ACCSP-10YV#KC0		Embossed Tape 3500 pcs/reel		

Notes:*1. For the application of the Safety Standard, following part number should be used.

ABSOLUTELY MAXIMUM RATINGS ($T_A = 25^\circ\text{C}$, unless otherwise specified)

Parameter		Symbol	Ratings	Unit
Diode	Forward Current	I_F	20	mA
	Reverse Voltage	V_R	5	V
	Power Dissipation Derating	$\Delta P_D/^\circ\text{C}$	1.2 ($T_A \geq 110^\circ\text{C}$)	mW/ $^\circ\text{C}$
	Power Dissipation	P_D	45	mW
Detector	Supply Voltage	V_{CC}	-0.5 ~ +30	V
	Output Voltage	V_O	-0.5 ~ V_{CC}	V
	Output Current	I_O	15	mA
	Power Dissipation Derating	$\Delta P_C/^\circ\text{C}$	4.15 ($T_A \geq 85^\circ\text{C}$)	mW/ $^\circ\text{C}$
	Power Dissipation	P_C	250	mW
Isolation Voltage *1		BV	5000	Vr.m.s.
Operating Ambient Temperature		T_A	-40 ~ +125	$^\circ\text{C}$
Storage Temperature		T_{stg}	-55 ~ +150	$^\circ\text{C}$

Notes: 1. AC Voltage for 1minute at $T_A=25^\circ\text{C}$, RH=60% between input and output.
Pins 1-2 shorted together, 3-5 shorted together.

RECOMMENDED OPERATING CONDITIONS

Parameter	Symbol	MIN.	TYP.	MAX	Unit
Supply Voltage	V_{CC}	4.5	15	25	V
High Level Forward Current	$I_{F(ON)}$	8	10	12	mA
Low Level forward voltage	$V_{F(OFF)}$	-2		0.8	V

ELECTRICAL CHARACTERISTICS

($T_A = -40 \sim +125^{\circ}\text{C}$, $V_{CC} = 15\text{V}$, unless otherwise specified)

Parameter		Symbol	Conditions	MIN.	TYP.*1	MAX.	Unit
Diode	Forward Voltage	V_F	$I_F = 10\text{ mA}$, $T_A = 25^{\circ}\text{C}$	1.35	1.56	1.75	V
	Reverse Current	I_R	$V_R = 3\text{ V}$, $T_A = 25^{\circ}\text{C}$			10	μA
	Terminal Capacitance	C_t	$V_F = 0\text{ V}$, $f = 1\text{ MHz}$		30		pF
Detector	High Level Supply Current	I_{CCH}	$V_{CC} = 20\text{V}$, $V_F = 0.8\text{V}$, $V_O = \text{Open}$		1.0	1.3	mA
	Low Level Supply Current	I_{CCL}	$V_{CC} = 20\text{V}$, $I_F = 10\text{mA}$, $V_O = \text{Open}$		1.0	1.3	mA
	High Level Output Current	I_{OH}	$V_{CC} = 20\text{V}$, $V_F = 0.8\text{V}$		0.01	50	μA
	Low Level Output Voltage	V_{OL}	$V_{CC} = 15\text{V}$, $I_F = 10\text{mA}$, $I_{OL} = 2.4\text{mA}$		0.13	0.6	V
Coupled	Threshold Input Current	I_{FHL}	$V_{CC} = 15\text{V}$, $V_O = 0.8\text{V}$, $I_O = 0.75\text{mA}$		0.8	5.0	mA
	Isolation Resistance	R_{I-O}	$V_{I-O} = 1\text{kVDC}$	10^{11}			Ω
	Isolation Capacitance	C_{I-O}	$V = 0\text{V}$, $f = 1\text{MHz}$		0.7		pF
	Propagation Delay Time (H \rightarrow L) ²	t_{PHL}	$V_{CC} = 15\text{V}$, $I_F = 10\text{mA}$, $R_L = 20\text{k}\Omega$, $C_L = 100\text{pF}$		180	500	ns
	Propagation Delay Time (L \rightarrow H) ²	t_{PLH}	$V_{THHL} = 1.5\text{V}$, $V_{THLH} = 2.0\text{V}$		420	750	ns
	Propagation Delay Difference	$t_{PLH} - t_{PHL}$		-200	240	650	ns
	Pulse Width Distortion (PWD) ²	$ t_{PHL} - t_{PLH} $			240	650	ns
	Common Mode Transient Immunity at High Level Output ³	CM_H	$T_A = 25^{\circ}\text{C}$, $I_F = 0\text{mA}$, $V_{CM} = 1.5\text{kV}$, $R_L = 20\text{k}\Omega$ $C_L = 100\text{pF}$, $V_O > 3.0\text{V}$	50			kV/ μs
Common Mode Transient Immunity at Low Level Output ³	CM_L	$T_A = 25^{\circ}\text{C}$, $I_F = 10\text{mA}$, $V_{CM} = 1.5\text{kV}$, $R_L = 20\text{k}\Omega$ $C_L = 100\text{pF}$, $V_O < 1.0\text{V}$	50			kV/ μs	

Notes*: 1. Typical values at $T_A = 25^{\circ}\text{C}$.

2. Test circuit for propagation delay time

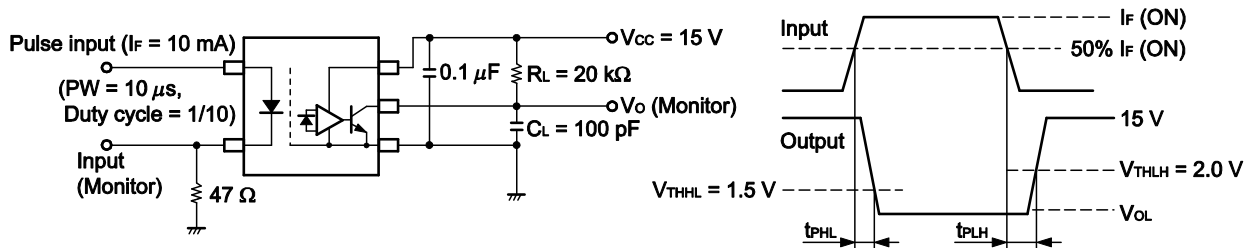

C_L includes probe and stray wiring capacitance.

3. Test circuit for common mode transient immunity

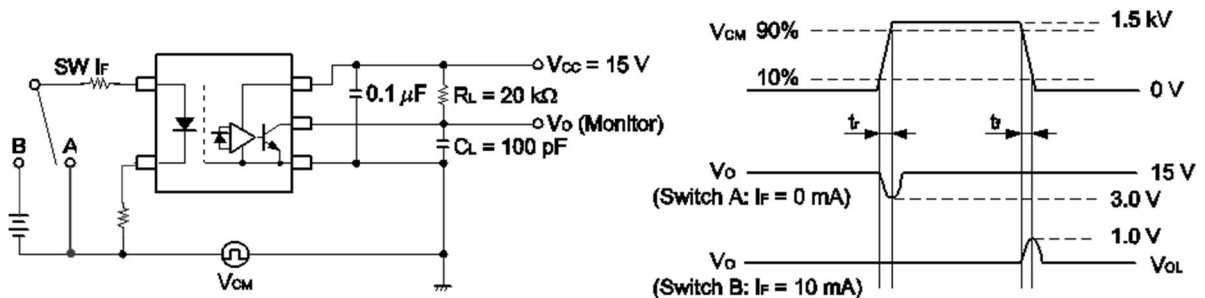

C_L includes probe and stray wiring capacitance.

USAGE CAUTIONS

1. This product is weak for static electricity by designed with high-speed integrated circuit so protect against static electricity when handling.
2. By-pass capacitor of more than 0.1 μF is used between V_{CC} and GND near device. Also, ensure that the distance between the leads of the photocoupler and capacitor is no more than 10 mm.
3. Avoid storage at a high temperature and high humidity.

TYPICAL CHARACTERISTICS (T_A = 25°C, unless otherwise specified)

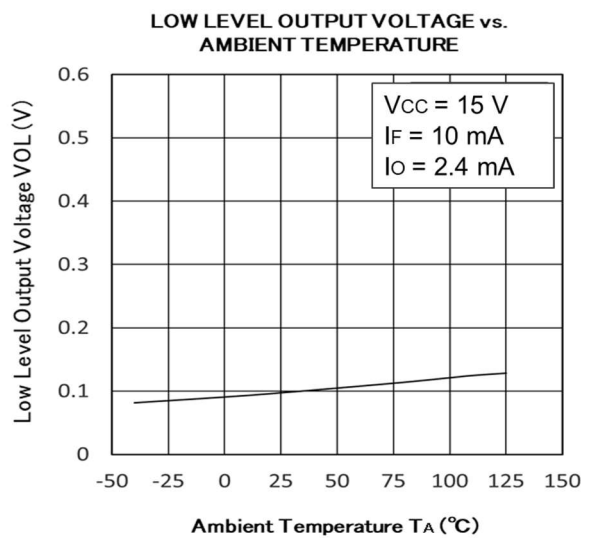
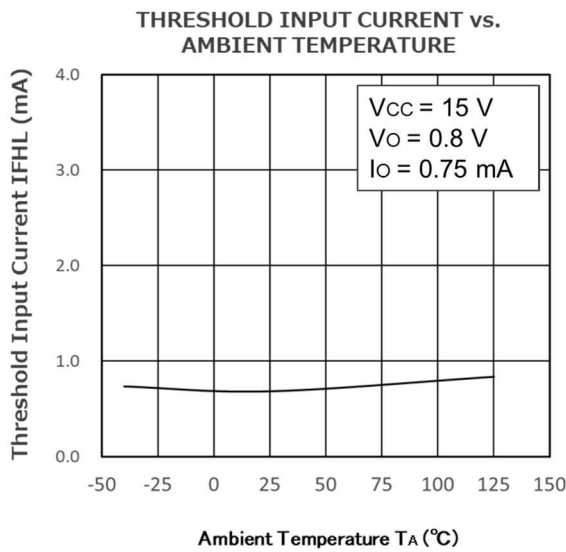
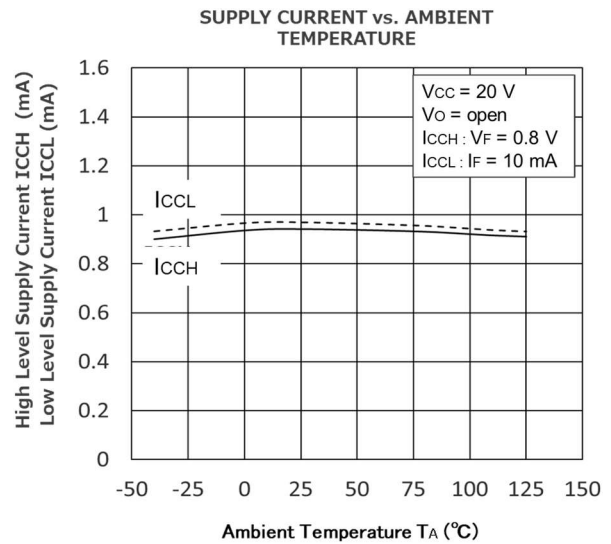
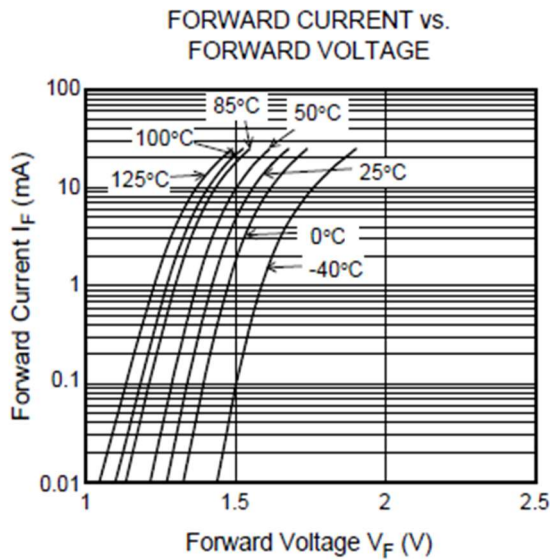
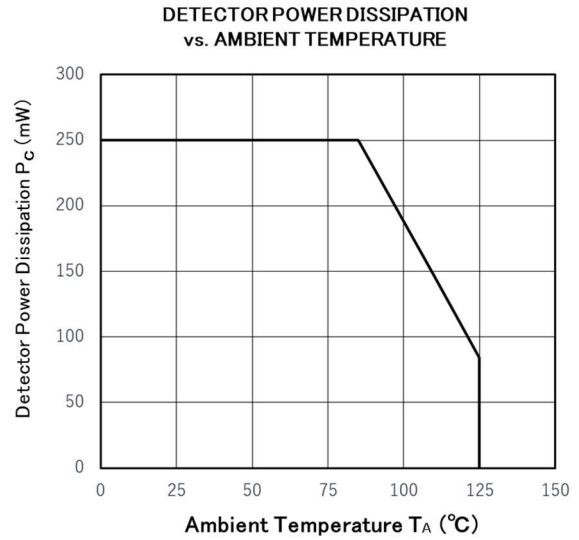
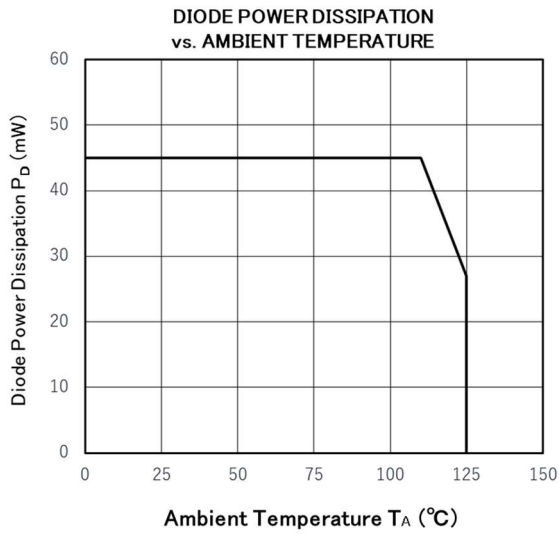

Remark The graphs indicate nominal characteristics.

TYPICAL CHARACTERISTICS (T_A = 25°C, unless otherwise specified)

OUTPUT CURRENT vs. FORWARD CURRENT

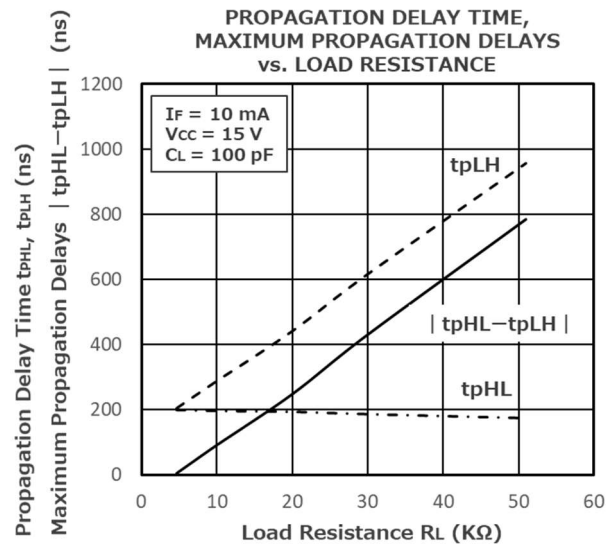
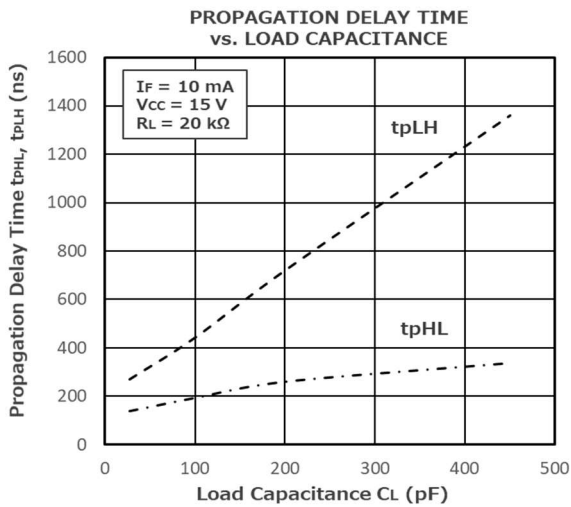
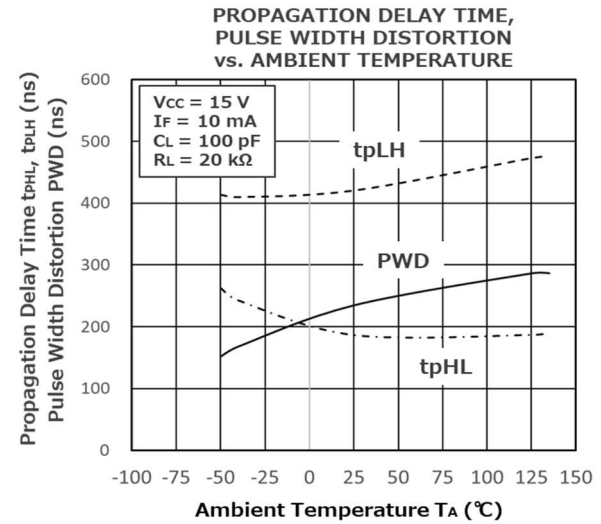
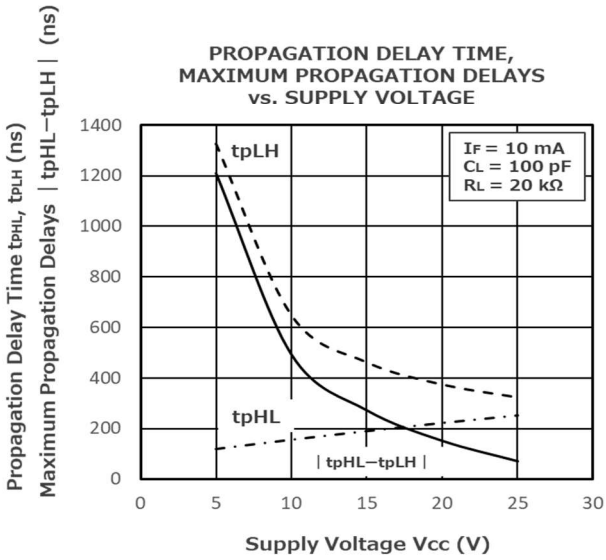
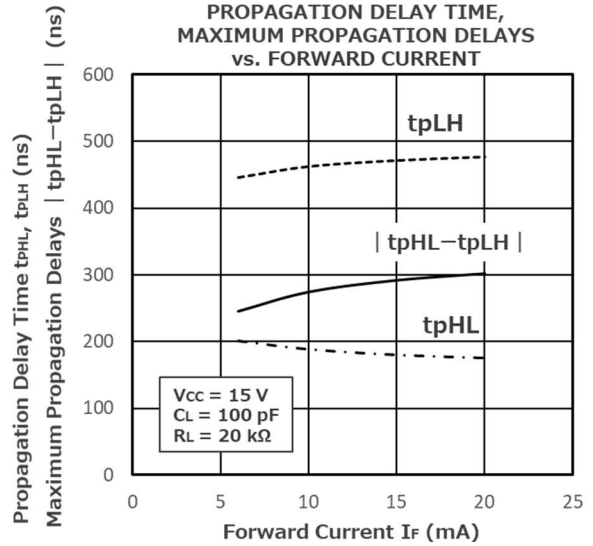
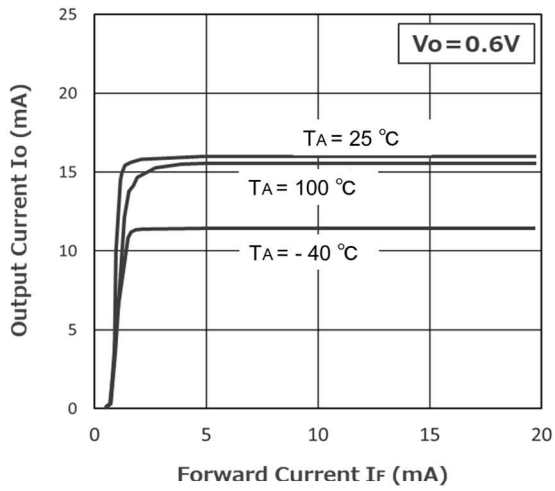

Remark The graphs indicate nominal characteristics.

TYPICAL CHARACTERISTICS (T_A = 25°C, unless otherwise specified)

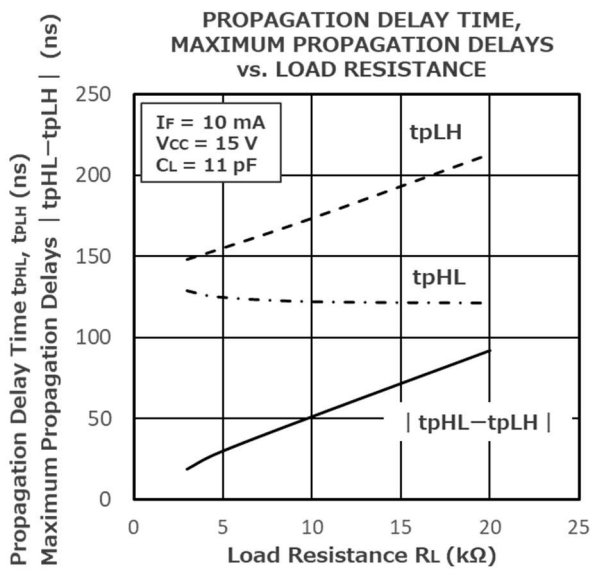

Remark The graphs indicate nominal characteristics.

TAPING SPECIFICATIONS (UNIT : mm)

Taping Direction

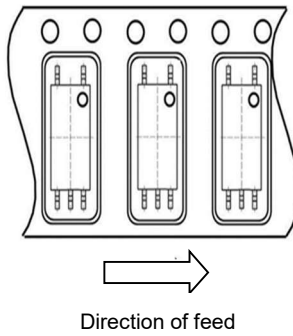

Outline and Dimensions (Tape)

Unit: mm

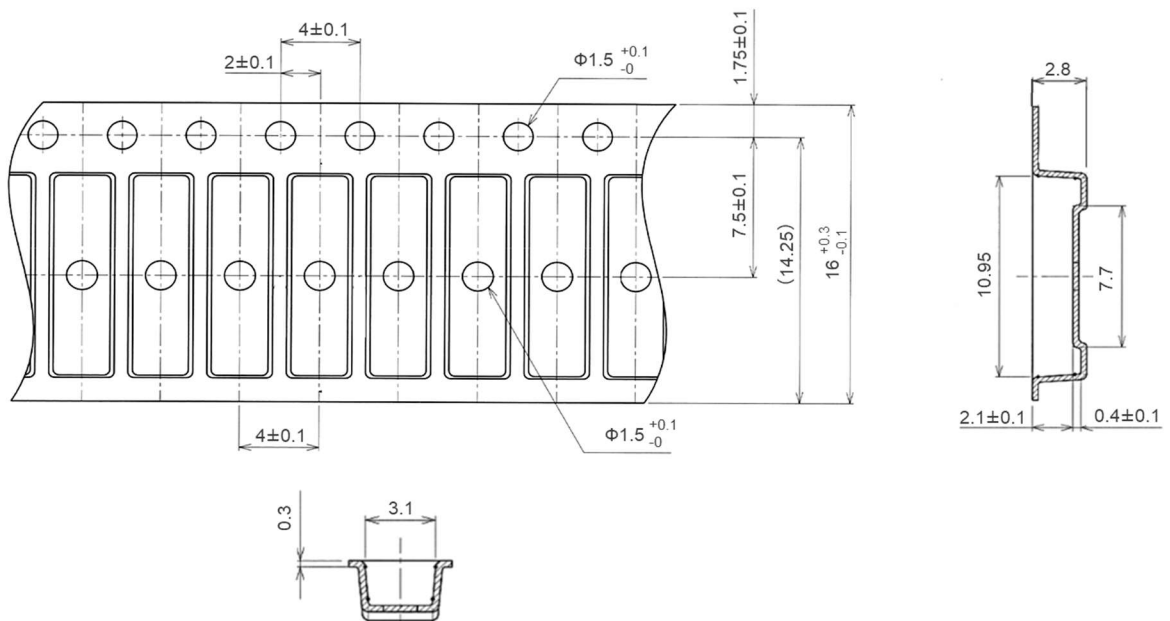

Outline and Dimensions (Reel)

Unit: mm

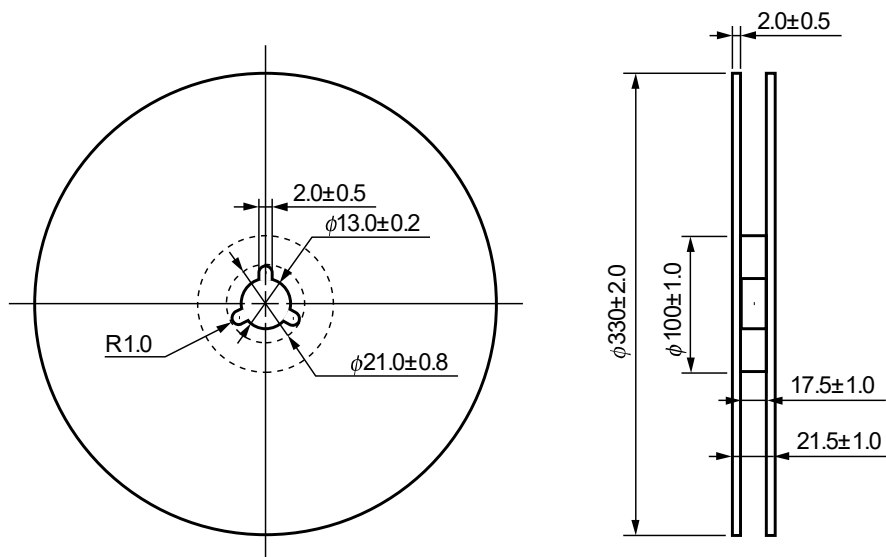

Packing: 3 500 pcs/reel

RECOMMENDED MOUNT PAD DIMENSIONS (UNIT : mm)

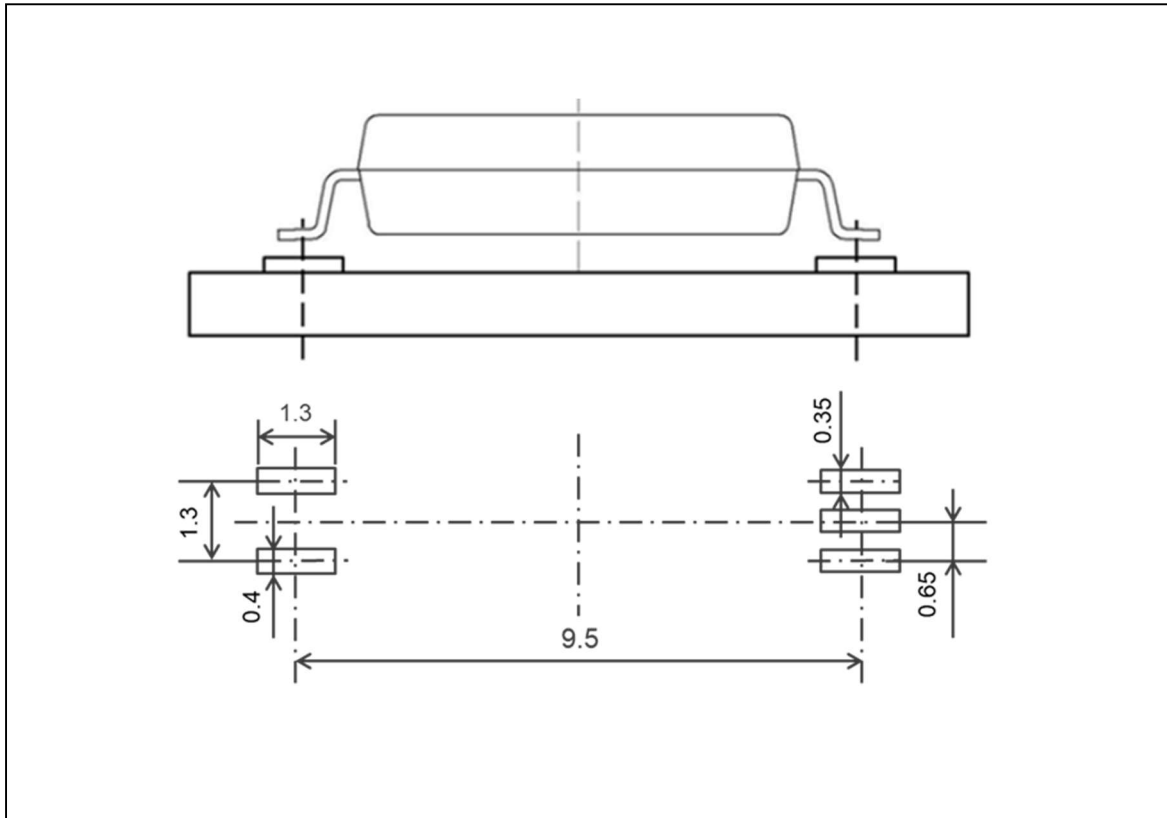

Remark All dimensions in this figure must be evaluated before use.

NOTES ON HANDLING

1. Recommended soldering conditions

(1) Infrared reflow soldering

- Peak reflow temperature 260°C or below (package surface temperature)
- Time of peak reflow temperature 10 seconds or less
- Time of temperature higher than 220°C 60 seconds or less
- Time to preheat temperature from 120 to 180°C 120±30 s
- Number of reflows Three
- Flux Rosin flux containing small amount of chlorine (The flux with a maximum chlorine content of 0.2 Wt% is recommended.)

Recommended Temperature Profile of Infrared Reflow

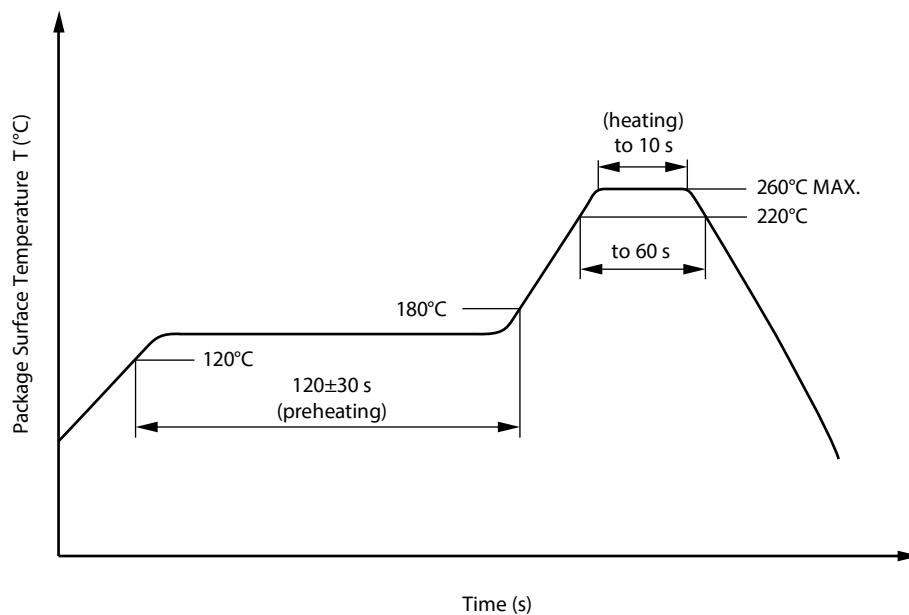

(2) Wave soldering

- Temperature 260°C or below (molten solder temperature)
- Time 10 seconds or less
- Preheating conditions 120°C or below (package surface temperature)
- Number of times One (Allowed to be dipped in solder including plastic mold portion.)
- Flux Rosin flux containing small amount of chlorine (The flux with a maximum chlorine content of 0.2 Wt% is recommended.)

(3) Soldering by Soldering Iron

- Peak Temperature (lead part temperature) 350°C or below
- Time (each pins) 3 seconds or less
- Flux Rosin flux containing small amount of chlorine
(The flux with a maximum chlorine content of 0.2 Wt% is recommended.)

(a) Soldering of leads should be made at the point 1.5 to 2.0 mm from the root of the lead

(b) Please be sure that the temperature of the package would not be heated over 100°C

(4) Cautions

- Flux Cleaning
Avoid cleaning with Freon based or halogen-based (chlorinated etc.) solvents.
- Do not use fixing agents or coatings containing halogen-based substances.

2. Cautions regarding noise

Be aware that when voltage is applied suddenly between the photocoupler's input and output at startup, the output transistor may enter the on state, even if the voltage is within the absolute maximum ratings.

SPECIFICATION OF VDE MARKS LICENSE DOCUMENT

Parameter	Symbol	Rating	Unit
Climatic test class (IEC 60068-1/DIN EN 60068-1)		40/125/21	
Dielectric strength			
maximum operating isolation voltage	U_{IORM}	1 075	V_{peak}
Test voltage (partial discharge test, procedure a for type test and random test)	U_{pr}	1 720	V_{peak}
$U_{pr} = 1.6 \times U_{IORM}, P_d < 5 \text{ pC}$			
Test voltage (partial discharge test, procedure b for all devices)	U_{pr}	2 016	V_{peak}
$U_{pr} = 1.875 \times U_{IORM}, P_d < 5 \text{ pC}$			
Highest permissible overvoltage	U_{IOTM}	8 000	V_{peak}
Degree of pollution (IEC 60664-1/DIN EN 60664-1 (VDE 0110-1))		2	
Comparative tracking index (IEC 60112/DIN EN 60112 (VDE 0303-11))	CTI	400	
Material group (IEC 60664-1/DIN EN 60664-1 (VDE 0110-1))		II	
Storage temperature range	T_{stg}	-55~+150	°C
Operating temperature range	T_A	-40~+125	°C
Isolation resistance, minimum value			
$V_{IO} = 500 \text{ V dc at } T_A = 25^\circ\text{C}$	Ris MIN.	10^{12}	Ω
$V_{IO} = 500 \text{ V dc at } T_A \text{ MAX. at least } 100^\circ\text{C}$	Ris MIN.	10^{11}	Ω
Safety maximum ratings (maximum permissible in case of fault, see thermal derating curve)			
Package temperature	T_{si}	175	°C
Current (input current I_F , $\Psi_i = 0$)	I_{si}	400	mA
Power (output or total power dissipation)	Ψ_i	700	mW
Isolation resistance $V_{IO} = 500 \text{ V dc at } T_A = T_{si}$	Ris MIN.	10^9	Ω

Method a) Destructive Test, Type and Sample Test

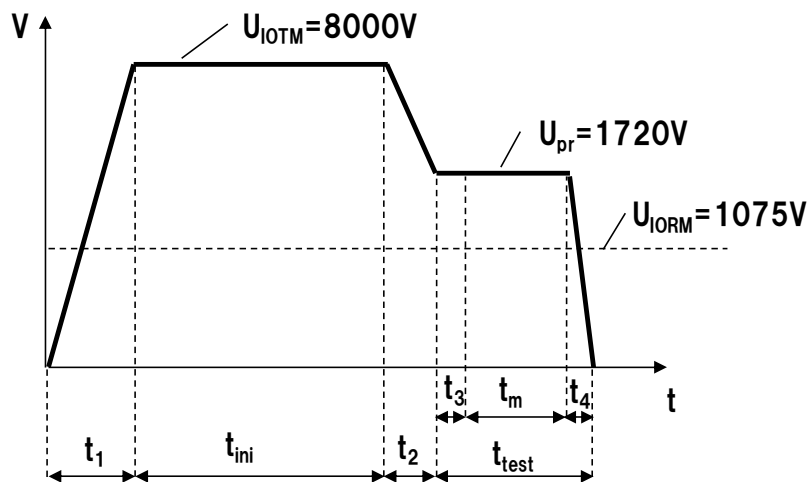

$t_1, t_2 = 1 \text{ to } 10 \text{ sec}$

$t_3, t_4 = 1 \text{ sec}$

$t_m \text{ (PARTIAL DISCHARGE)} = 10 \text{ sec}$

$t_{test} = 12 \text{ sec}$

$t_{ini} = 60 \text{ sec}$

Method b) Non-destructive Test, 100% Production Test

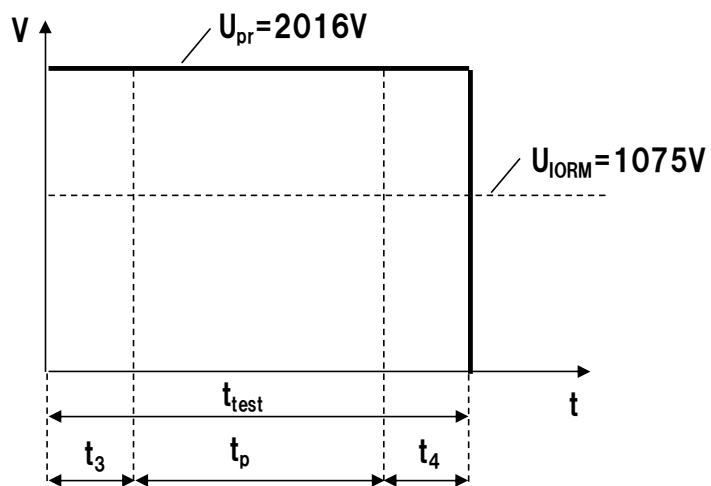

$$t_3, t_4 = 0.1 \text{ sec}$$

$$t_p \text{ (PARTIAL DISCHARGE)} = 1.0 \text{ sec}$$

$$t_{test} = 1.2 \text{ sec}$$

Caution	GaAs Products	<p>This product uses gallium arsenide (GaAs). GaAs vapor and powder are hazardous to human health if inhaled or ingested, so please observe the following points.</p> <ul style="list-style-type: none">• Follow related laws and ordinances when disposing of the product. If there are no applicable laws and/or ordinances, dispose of the product as recommended below.<ol style="list-style-type: none">1. Commission a disposal company able to (with a license to) collect, transport and dispose of materials that contain arsenic and other such industrial waste materials.2. Exclude the product from general industrial waste and household garbage, and ensure that the product is controlled (as industrial waste subject to special control) up until final disposal.• Do not burn, destroy, cut, crush, or chemically dissolve the product.• Do not lick the product or in any way allow it to enter the mouth.
----------------	---------------	--

All trademarks and registered trademarks are the property of their respective owners.