

RV1S9353A

R08DS0174EJ0100

Rev.1.00

Mar 23, 2020

Optically Isolated Delta-Sigma Modulator

DESCRIPTION

The RV1S9353A is an optically isolated Delta – Sigma Modulator that includes high-Accuracy A/D convertor and converts an analog voltage input into one-bit data stream. The RV1S9353A provides Effective Number of Bit (ENOB) is 13.8bits (typ) with a Sinc³ digital filter.

The RV1S9353A is designed specifically for high common mode transient immunity (CMR) and high linearity (nonlinearity). The RV1S9353A is suitable for current sensing and voltage sensing in motor drives.

FEATURES

- Internal Reference Voltage Tolerance (GE = ±0.5 % TYP.)
- Effective Number of Bit (ENOB = 13.8 bits TYP.)
- Operating Ambient Temperature (TA = -40 to 110 °C)
- Non-linearity (INL = 25 LSB MAX.)
- Input Offset Voltage (VOS = 2 mV MAX.)
- Input Offset Voltage Drift vs. Temperature (|dVos/dTA| = 2.5 μV/°C MAX.)
- Output Clock Frequency (fCLK = 10 MHz TYP.)
- High common mode transient immunity (CMR = 15 kV/μs MIN.)
- Long creepage distance (8 mm MIN.)
- Embossed tape product: RV1S9353ACCSP-120x#KC0: 2 000 pcs/reel
- Pb-Free product
- Safety standards
 - UL approved: No. UL1577, Double protection
 - CSA approved: CAN/CSA-C22.2 No.62368-1, Reinforced insulation
 - DIN EN 60747-5-5 approved (Option)

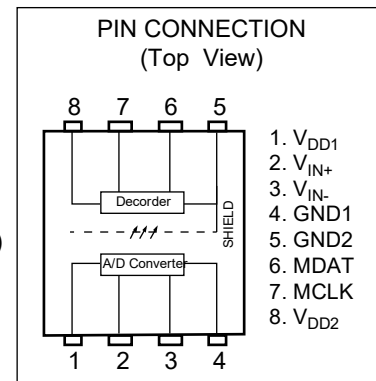

APPLICATIONS

- AC Servo, inverter
- Solar inverter
- Measurement equipment

Start of mass production

Mar.2020

PACKAGE DIMENSIONS (UNIT: mm)

Lead Bending Type (Gull-wing) For Long Creepage Distance (Surface Mount)

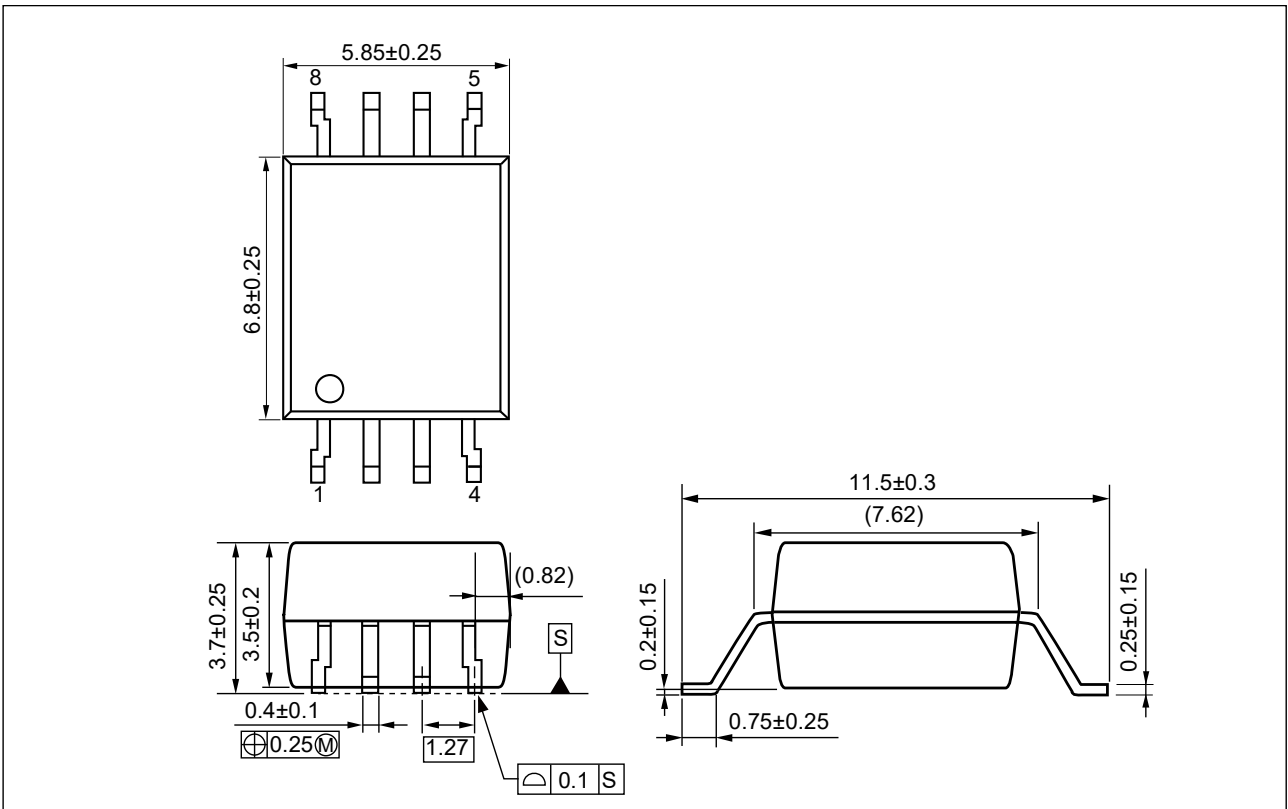

Weight: 0.316g (typ.)

PHOTOCOUPLER CONSTRUCTION

Parameter	MIN.
Air Distance	8 mm
Creepage Distance	8 mm
Isolation Distance	0.4 mm

MARKING EXAMPLE

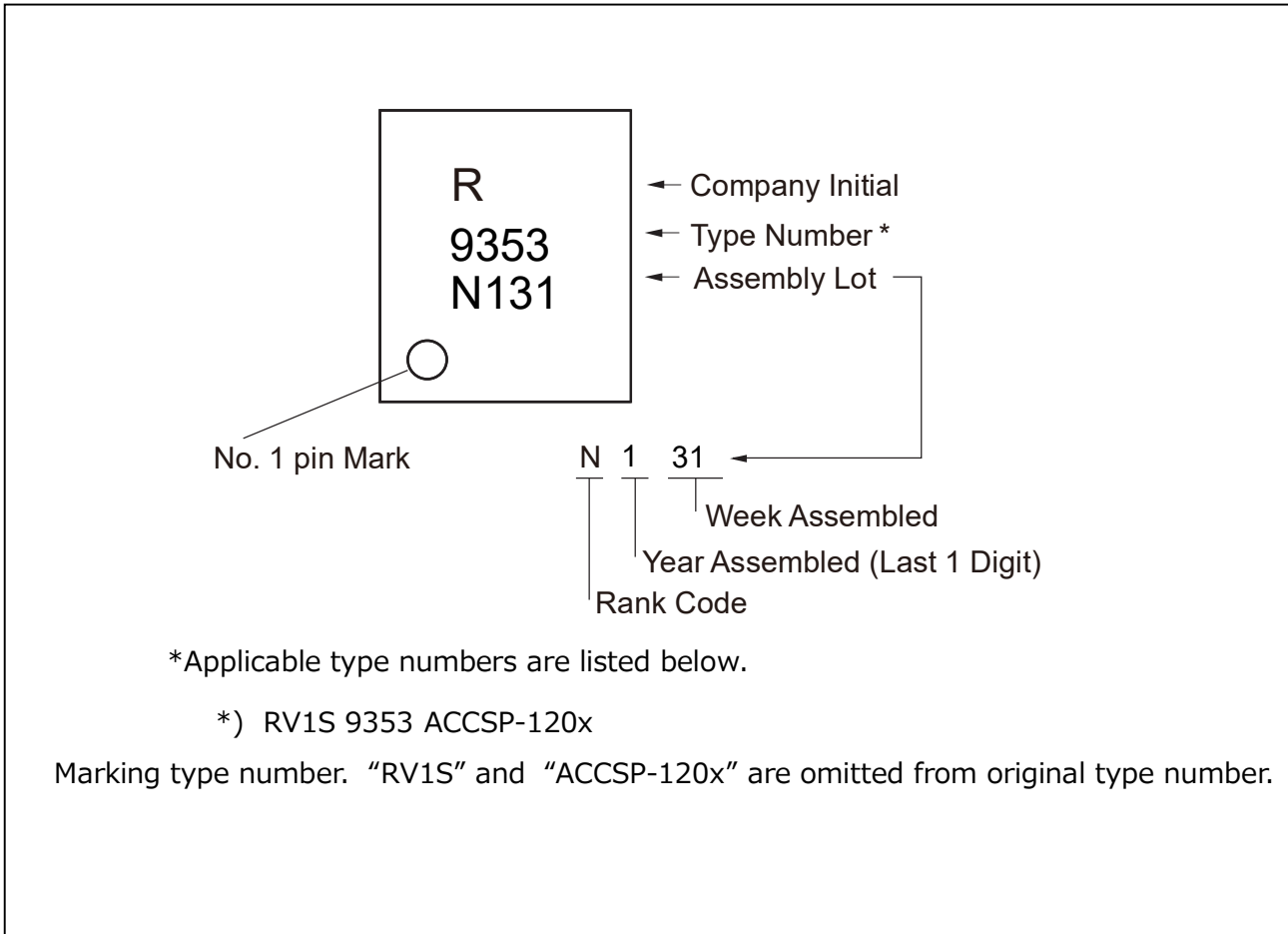

ORDERING INFORMATION

Part Number	Order Number	Solder Plating Specification	Packing Style	Safety Standard Approval	Application Part Number*1
RV1S9353ACCSP-120C	RV1S9353ACCSP-120C#SC0	Pb-Free (Ni/Pd/Au)	20 pcs (Tape 20 pcs cut)	Standard products (UL, CSA approved)	RV1S9353A
	RV1S9353ACCSP-120C#KC0		Embossed Tape 2 000 pcs/reel		
RV1S9353ACCSP-120V	RV1S9353ACCSP-120V#SC0		20 pcs (Tape 20 pcs cut)	UL, CSA, DIN EN 60747-5-5 approved	
	RV1S9353ACCSP-120V#KC0		Embossed Tape 2 000 pcs/reel		

*1 For the application of the Safety Standard, following part number should be used.

ABSOLUTE MAXIMUM RATINGS ($T_A = 25^\circ\text{C}$, unless otherwise specified)

Parameter	Symbol	Ratings	Unit
Operating Ambient Temperature	T_A	-40 to +110	$^\circ\text{C}$
Storage Temperature	T_{stg}	-55 to +150	$^\circ\text{C}$
Supply Voltage	$V_{\text{DD1}}, V_{\text{DD2}}$	6	V
Input Voltage ^{*1}	$V_{\text{IN+}}, V_{\text{IN-}}$	-2 to $V_{\text{DD1}} + 0.5$	V
Input Voltage ^{*1,2}	$V_{\text{IN+}}, V_{\text{IN-}}$	-6 to $V_{\text{DD1}} + 0.5$	V
Output Voltage	MCLK, MDAT	6	V
Isolation Voltage ^{*3}	BV	5 000	Vr.m.s.

*1 The input voltage of $V_{\text{IN+}}$ and $V_{\text{IN-}}$ terminals is less than 6V.

*2 Duration of time is within 2 seconds.

*3 AC voltage for 1 minute at $T_A = 25^\circ\text{C}$, RH = 60% between input and output.
Pins 1-4 shorted together, 5-8 shorted together.

RECOMMENDED OPERATING CONDITIONS

Parameter	Symbol	MIN.	TYP.	MAX.	Unit
Operating Ambient Temperature	T_A	-40		110	$^\circ\text{C}$
Supply Voltage V_{DD1}	V_{DD1}	4.5	5	5.5	V
Supply Voltage V_{DD2}	V_{DD2}	3.0		5.5	V
Input Voltage (Accurate and Linear) ^{*1}	$V_{\text{IN+}}, V_{\text{IN-}}$	-200		200	mV

*1 Using $V_{\text{IN-}} = 0\text{ V}$ (to be connected to GND1) is recommended. Avoid using $V_{\text{IN-}}$ of 2.5 V or more, because the internal test mode is activated when the voltage $V_{\text{IN-}}$ reaches more than 2.5 V.

ELECTRICAL CHARACTERISTICS

(TYP.: $T_A = 25^\circ\text{C}$, $V_{IN+} = V_{IN-} = 0\text{ V}$, $V_{DD1} = V_{DD2} = 5\text{ V}$,
 MIN., MAX.: refer to RECOMMENDED OPERATING CONDITIONS, unless otherwise specified)

Parameter	Symbol	Conditions	MIN.	TYP.	MAX.	Unit
Input Supply Current	I_{DD1}	$V_{IN+} = -320 \sim +320\text{ mV}$		11.5	15.5	mA
Output Supply Current	I_{DD2}	$V_{DD2} = 5\text{ V}$		5	8	mA
		$V_{DD2} = 3.3\text{ V}$		4.5	7	mA
Input Bias Current	I_{IN}	$V_{DD1} = V_{DD2} = 5\text{ V}$, $V_{IN+} = 0\text{ V}$		-2.5		μA
Low Level Saturated Output Voltage	V_{OL}	$I_{OUT} = 1.6\text{ mA}$			0.6	V
High Level Saturated Output Voltage	V_{OH}	$I_{OUT} = -200\ \mu\text{A}$	$V_{DD2} - 0.6$	$V_{DD2} - 0.1$		V
Output Short-circuit Current	$ I_{OSC} $	$V_{OUT} = V_{DD2}$ or $V_{OUT} = \text{GND2}$		18	40	mA
Equivalent Input Resistance	R_{IN}	V_{IN+} or V_{IN-} single ended		500		$\text{k}\Omega$
Output Clock Frequency	f_{CLK}		9	10	11	MHz
Isolation Resistance	R_{I-O}	$V_{I-O} = 1\text{ kVDC}$, $T_A = 25^\circ\text{C}$	10^{11}			Ω
Isolation Capacitance	C_{I-O}	$f = 1\text{ MHz}$		0.7		pF
Data Hold Time ^{*1}	t_{HDDAT}		10			ns
Common Mode Transient Immunity ^{*2}	CMR	$V_{CM} = 1\text{ kV}$, $T_A = 25^\circ\text{C}$	15	25		$\text{kV}/\mu\text{s}$

*1 The data hold time (t_{HDDAT}) is that the data (MDAT) will stay stable following the rising edge of the clock (MCLK). t_{HDDAT} is shown in the below timing chart.

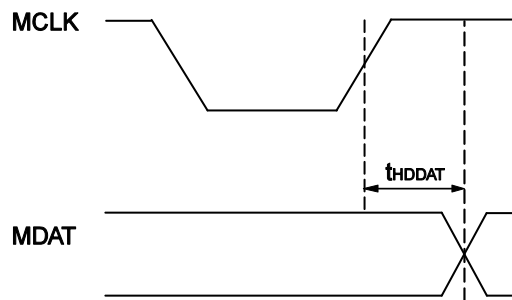

Fig. Timing Chart

*2 Common Mode Transient Immunity (CMR) is specified by the rate of rise / fall of a pulse applied between GND1 on the input side and GND2 on the output side (pins 4 and 5) by using the circuit shown in Fig. 6 CMR Test Circuit. CMR is defined at the point that clock signals are corrupted.

ELECTRICAL CHARACTERISTICS (Tested with Sinc³ filter, 256 decimation ratio.)

(TYP.: $T_A = 25^\circ\text{C}$, $V_{IN+} = V_{IN-} = 0\text{ V}$, $V_{DD1} = V_{DD2} = 5\text{ V}$,
MIN., MAX.: refer to RECOMMENDED OPERATING CONDITIONS, unless otherwise specified)

Parameter	Symbol	Conditions	MIN.	TYP.	MAX.	Unit
Integral Non-linearity *3	INL	$T_A = -40 \sim 85^\circ\text{C}$, $V_{IN+} = -200 \sim +200\text{ mV}$		3	15	LSB
		$T_A = 85 \sim 110^\circ\text{C}$,			25	LSB
Differential Non-linearity *4	DNL	$T_A = -40 \sim 110^\circ\text{C}$, $V_{IN+} = -200 \sim +200\text{ mV}$			0.9	LSB
Input Offset Voltage *5	V_{OS}		-2	0	2	mV
Input Offset Voltage Drift vs. Temperature	$ dV_{OS}/dT_A $			0.2	2.5	$\mu\text{V}/^\circ\text{C}$
Input Offset Voltage Drift vs. Supply Voltage	$ dV_{OS}/dV_{DD1} $			40		$\mu\text{V}/\text{V}$
Internal Reference Voltage *6	V_{REF}			320		mV
Absolute Internal Reference Voltage Tolerance	G_E	$T_A = 25^\circ\text{C}$	-0.5		0.5	%
		$T_A = -40 \sim 110^\circ\text{C}$	-1		1	%
Internal Reference Voltage Drift vs. Temperature	$ dV_{REF}/dT_A $			30	60	ppm/ $^\circ\text{C}$
Internal Reference Voltage Drift vs. Supply Voltage	$ dV_{REF}/dV_{DD1} $			0.2		mV/V
Input DC Common-Mode Rejection Ratio *7	$CMRR_{IN}$			80		dB

*3 Integral non-linearity (INL) is the maximum deviation between the ideal conversion line (best-fit line) and measured points. The best-fit line is obtained by using the least-squares method from the differential input voltage ($V_{IN+} - V_{IN-}$: $V_{IN+} = -200\text{ mV}$ to 200 mV , $V_{IN-} = 0\text{ V}$) and the output data that is measured under the circuit shown in **Fig. 7 INL Test Circuit**. INL is defined as the ratio (%) obtained by dividing [Half of the peak to peak value of the deviation] by [full-scale differential input voltage 400 mV].

For example, if the differential input voltage is $V_{IN+} = -200\text{ mV}$ to 200 mV , and the peak to peak value of the deviation is 0.49 mV, Integral non-linearity is obtained as follows:

$$\text{INL} = 0.49\text{ mV} / (2 \times 400\text{ mV}) = 0.06\%$$

And Input Full-Scale 640 mV (-320 to 320 mV) of RV1S9353A is assigned 16 bits ($2^{16} = 65536$).

Therefore, Least Significant Bit (LSB) is $9.75\ \mu\text{V}$.

By LSB indication, above-mentioned INL is $0.49\text{ mV} / (2 \times 0.00975\text{ mV}) = 25\text{ LSBs}$.

*4 Differential non-linearity (DNL) is the difference between a measured code width and ideal 1 LSB in the ADC transfer curve.

*5 Input offset voltage (V_{OS}) is a measured value after Sinc³ digital filter when the input voltage is 0 V ($V_{IN+} = V_{IN-} = 0\text{ V}$).

*6 Absolute Internal Reference Voltage Tolerance (G_E) is the gap rate between the ideal conversion line slope (Slope = 1) and a best-fit line slope that provided by the least-squares method from a real conversion level output for the differential input voltage ($V_{IN+} - V_{IN-}$: $V_{IN+} = -200\text{ mV}$ to 200 mV , $V_{IN-} = 0\text{ V}$).

*7 Input DC Common-Mode Rejection Ratio ($CMRR_{IN}$) is the ratio of the differential signal ($V_{IN+} = -200\text{ mV}$ to 200 mV , $V_{IN-} = 0\text{ V}$) to the common-mode signal ($V_{IN+} = V_{IN-} = -200\text{ mV}$ to 200 mV : Both input pins are connected). $CMRR_{IN}$ is defined as follows,

$$CMRR_{IN}(\text{dB}) = 20 \log (V_{do}/V_{co})$$

V_{do} : Output voltage when the differential signal voltage input

V_{co} : Output voltage when the common-mode signal voltage input

ELECTRICAL CHARACTERISTICS (Tested with Sinc³ filter, 256 decimation ratio.)

(TYP.: TA = 25°C, VIN+ = VIN- = 0 V, VDD1 = VDD2 = 5 V,

MIN., MAX.: refer to RECOMMENDED OPERATING CONDITIONS, unless otherwise specified)

Parameter	Symbol	Conditions	MIN.	TYP.	MAX.	Unit
Signal to Noise Ratio *8	SNR	VIN+ = 35 Hz, 400 mVpk-pk (141 mVr.m.s.) sine wave	80	85		dB
Signal to Noise and Distortion Ratio *9	SNDR		69	79		dB
Effective Number of Bit *10	ENOB			13.8		bits

*8 Signal to Noise Ratio (SNR) is the ratio of the AC signal power to the noise power that excludes harmonic signals and DC. SNR is defined as follows,

$$\text{SNR (dB)} = 10 \log(P_s/P_N)$$

Ps: Signal power (fundamental)

PN: Noise power (excluding harmonic signals and DC)

*9 Signal to Noise and Distortion ratio (SNDR) is the ratio of the AC signal power (fundamental) to the noise power plus distortion power. SNDR is defined as follows,

$$\text{SNDR (dB)} = 10 \log(P_s/(P_N + P_{H2} + P_{H3} + \dots + P_{H5}))$$

Ps: Signal power (fundamental)

PN: Noise power (excluding harmonic signals and DC)

PH2, PH3 ... PH5: Second through fifth harmonics power

*10 Effective Number of Bit (ENOB) is the effective resolution of ADC that is considered the noise. ENOB is defined as follows,

$$\text{ENOB (bits)} = (\text{SNR} - 1.76)/6.02$$

TEST CIRCUIT

Fig.1 IDD1 Test Circuit

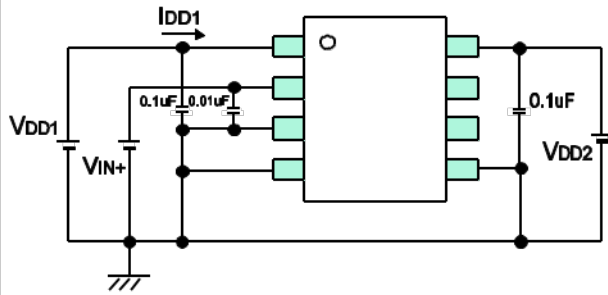

Fig.2 IDD2 Test Circuit

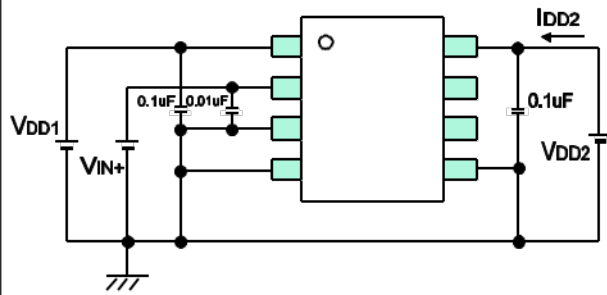

Fig.3 IIN Test Circuit

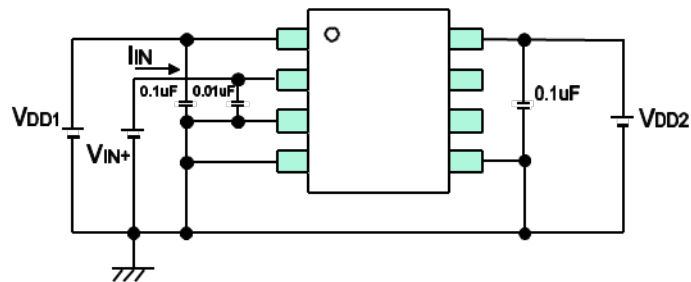
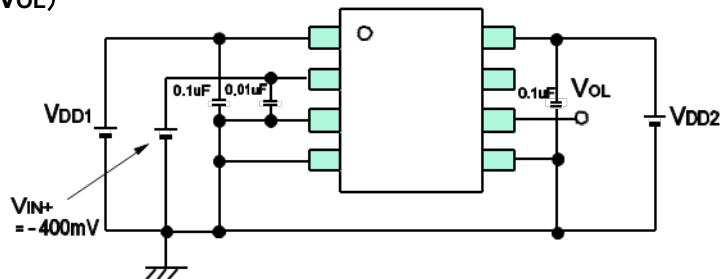

Fig.4 Vout Test Circuit

(VOL)



(VOH)

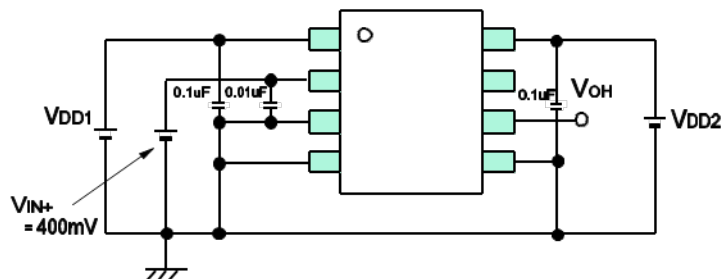

Fig.5 Iosc Test Circuit

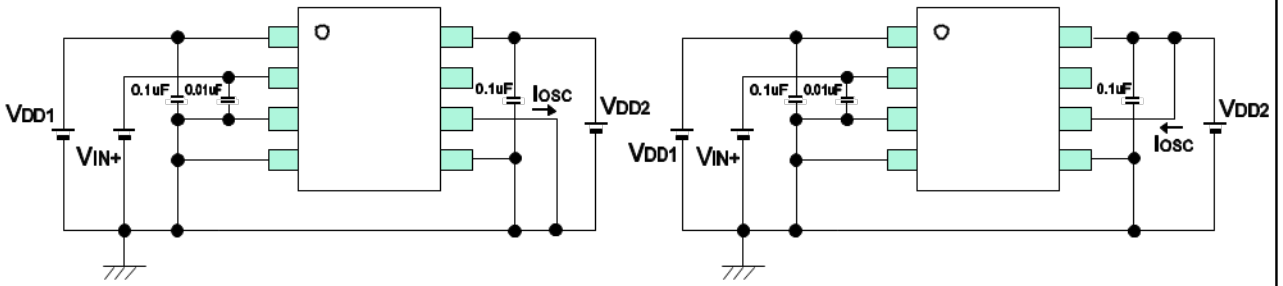

Fig.6 CMR Test Circuit

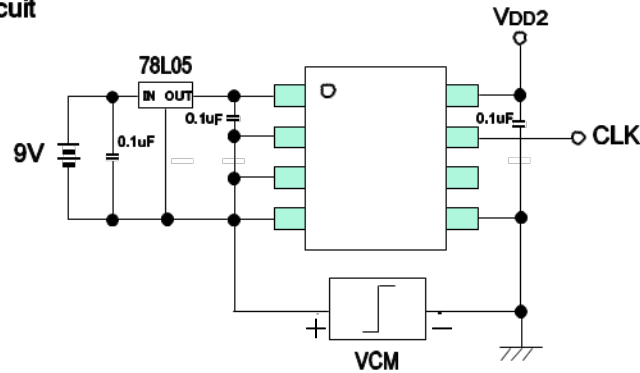
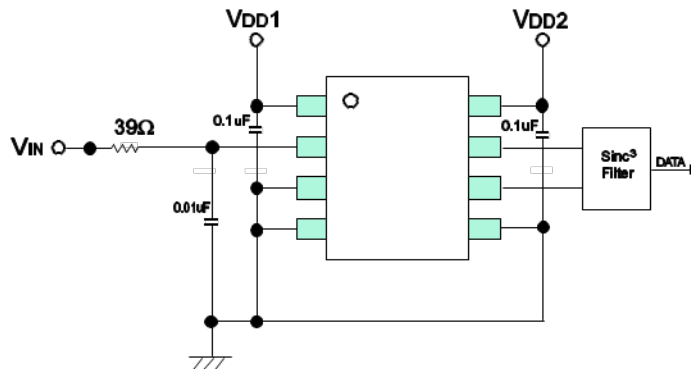
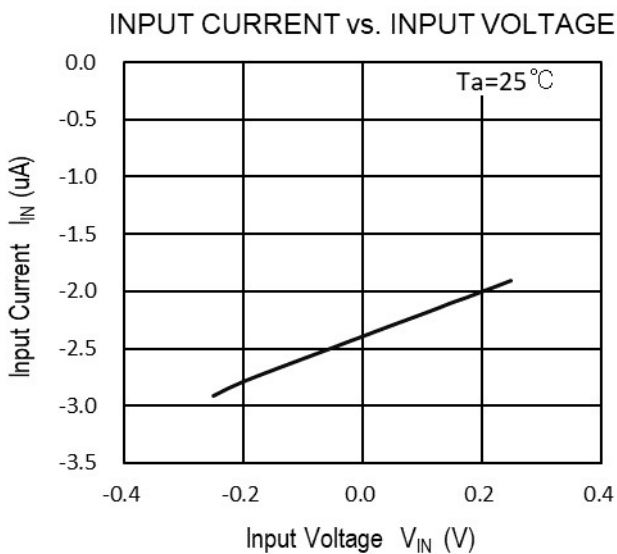
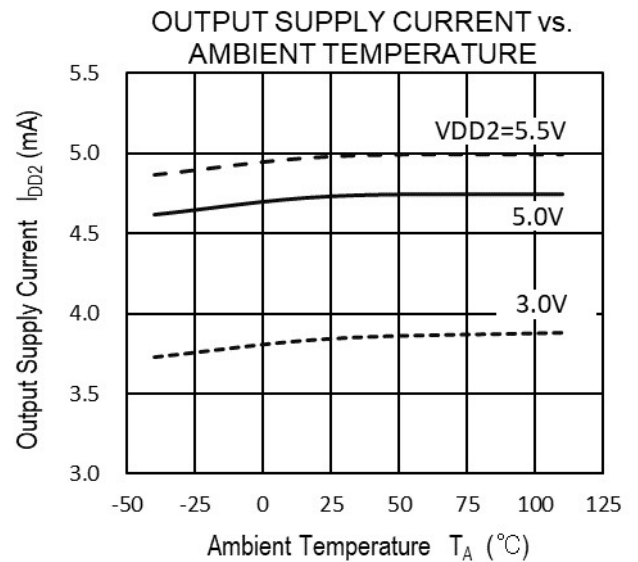
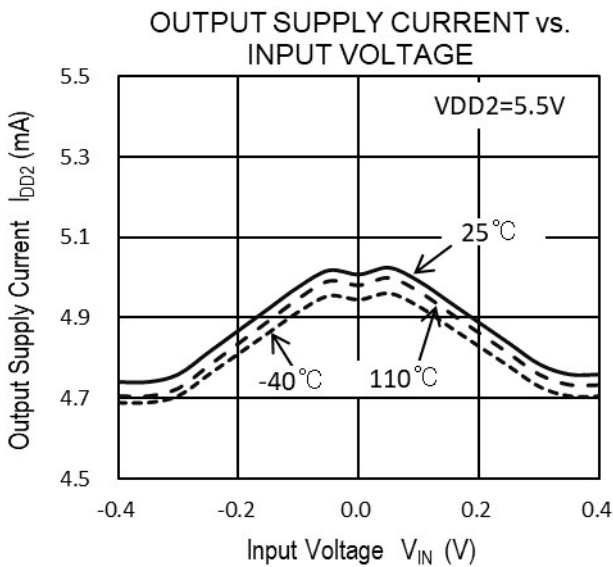
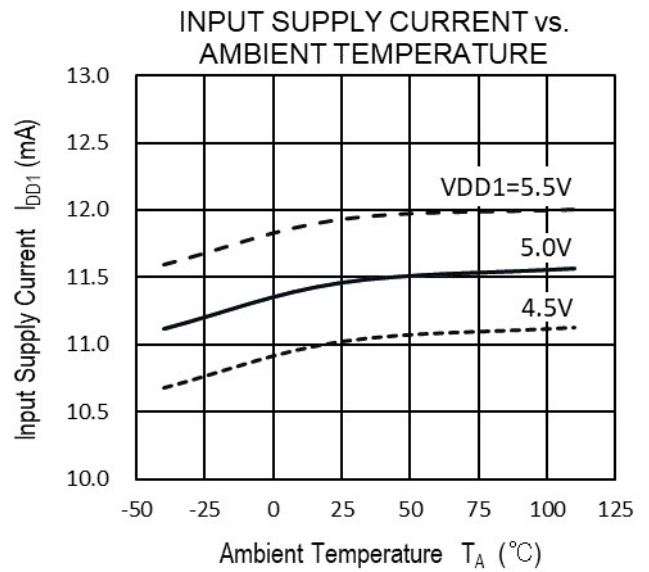
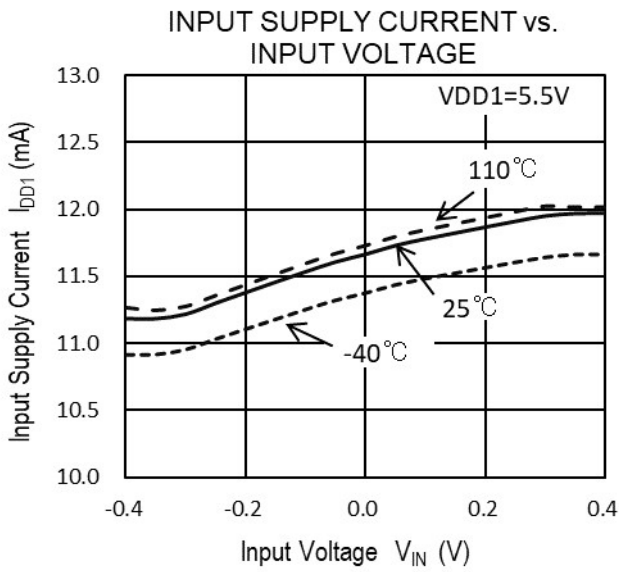

Fig.7 Vos, INL, DNL, Ge, SNR, SNDR, ENOB Test Circuit



TYPICAL CHARACTERISTICS (TA = 25°C, VIN+ = VIN- = 0 V, VDD1 = VDD2 = 5 V, tested with Sinc³ filter, 256 decimation ratio, unless otherwise specified)



Remark The graphs indicate nominal characteristics.

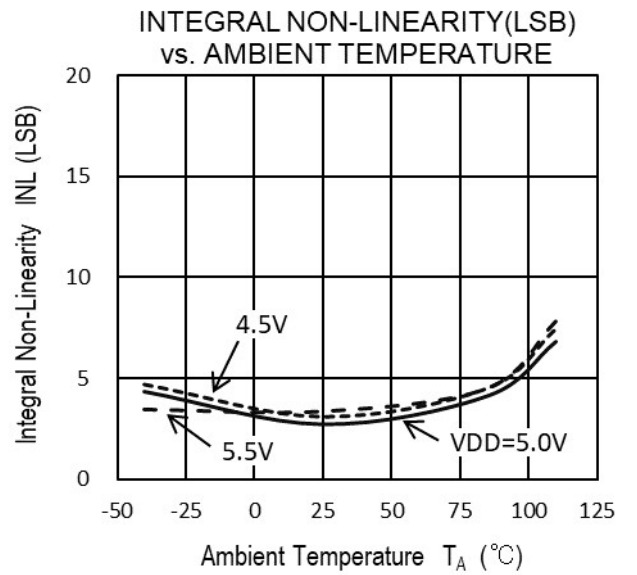
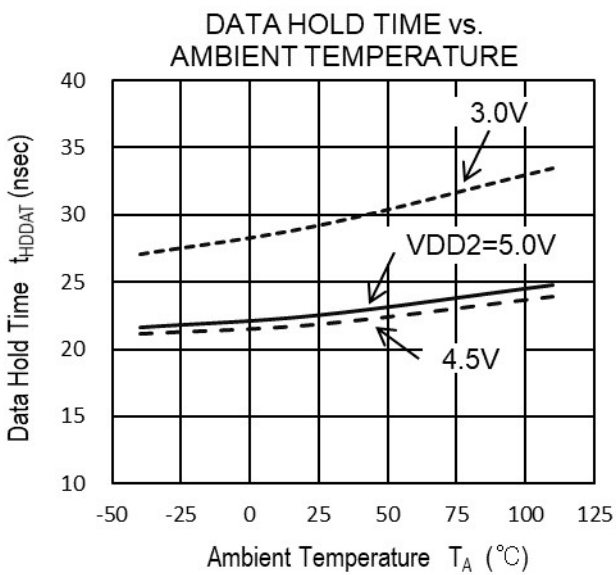
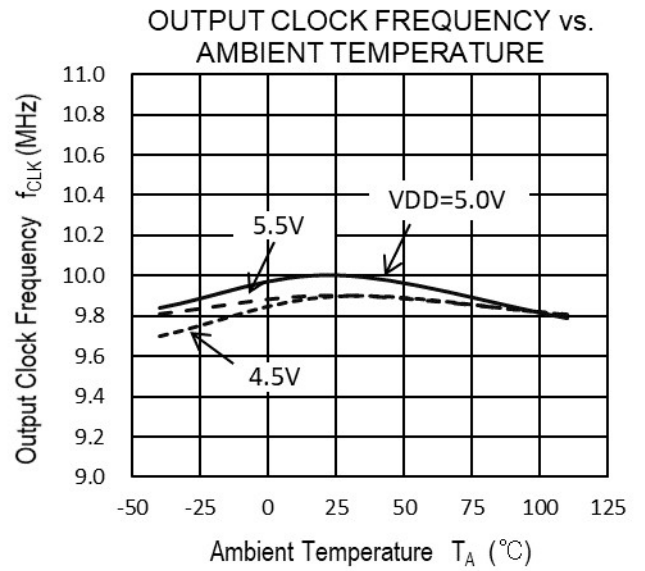
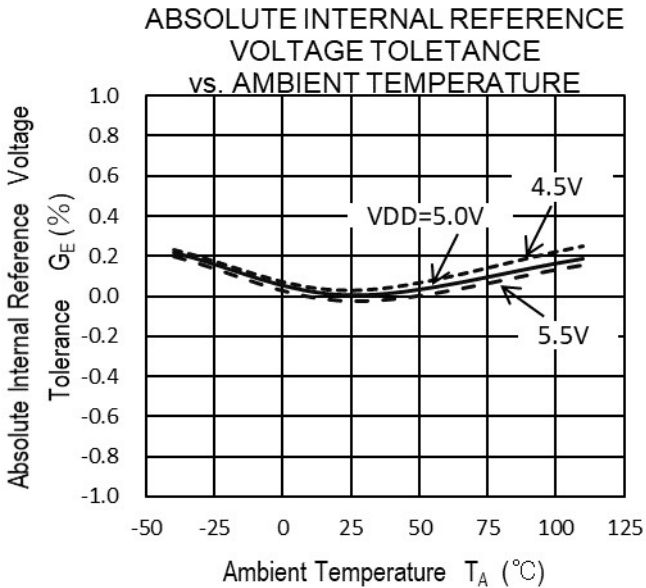
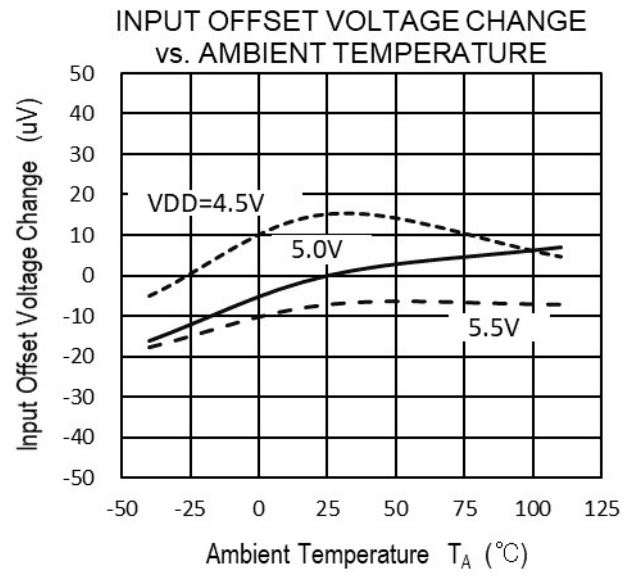
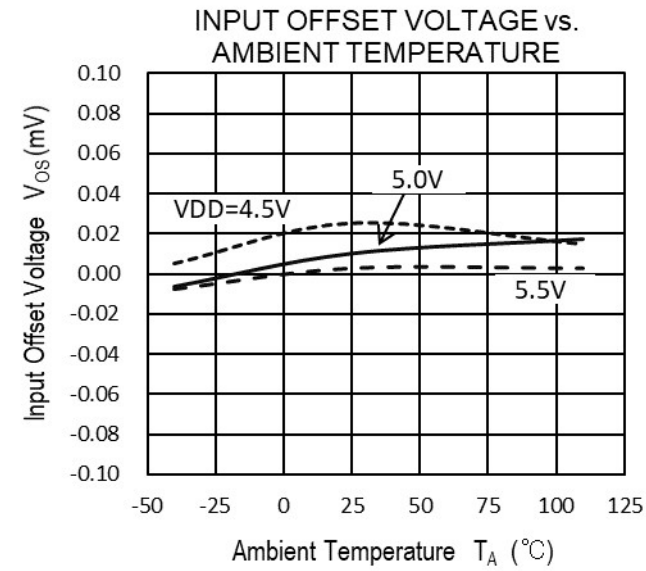

Remark The graphs indicate nominal characteristics.

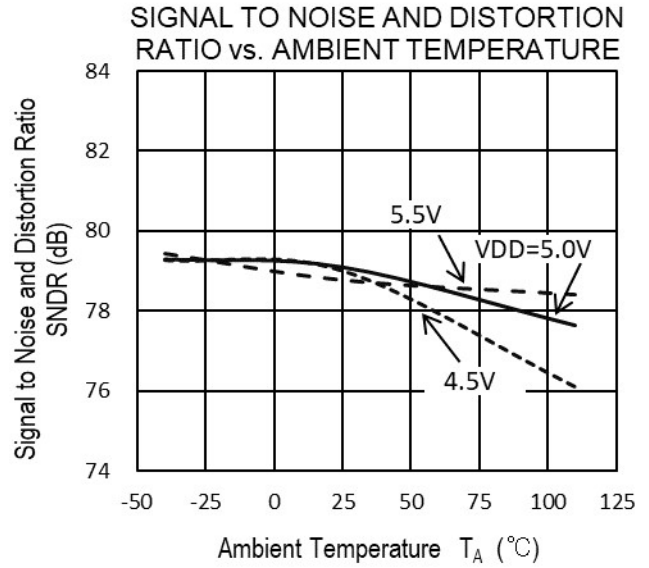
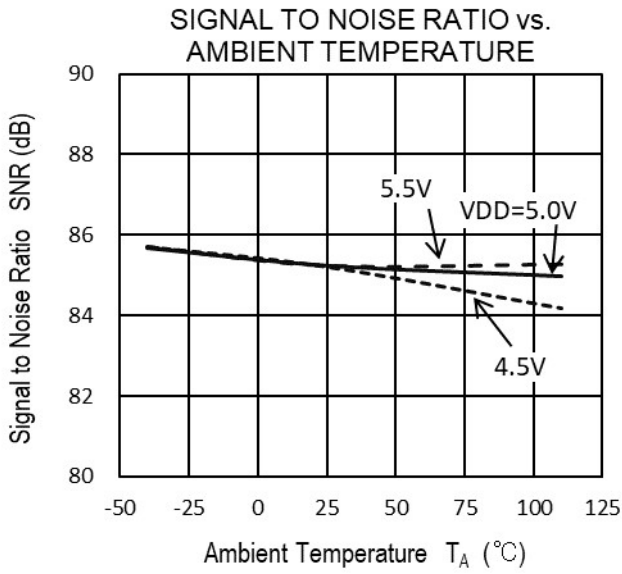

Remark The graphs indicate nominal characteristics.

TAPING SPECIFICATIONS (UNIT: mm)

Tape Direction

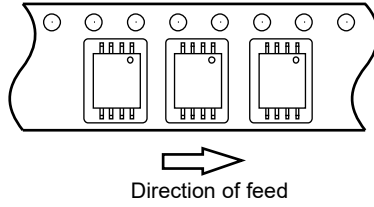

Outline and Dimensions (Tape)

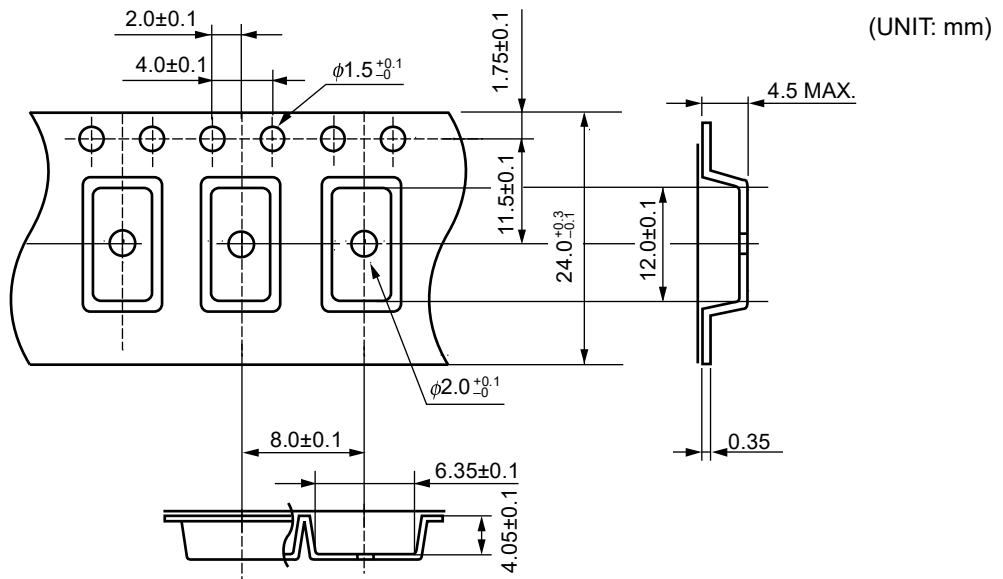

Outline and Dimensions (Reel)

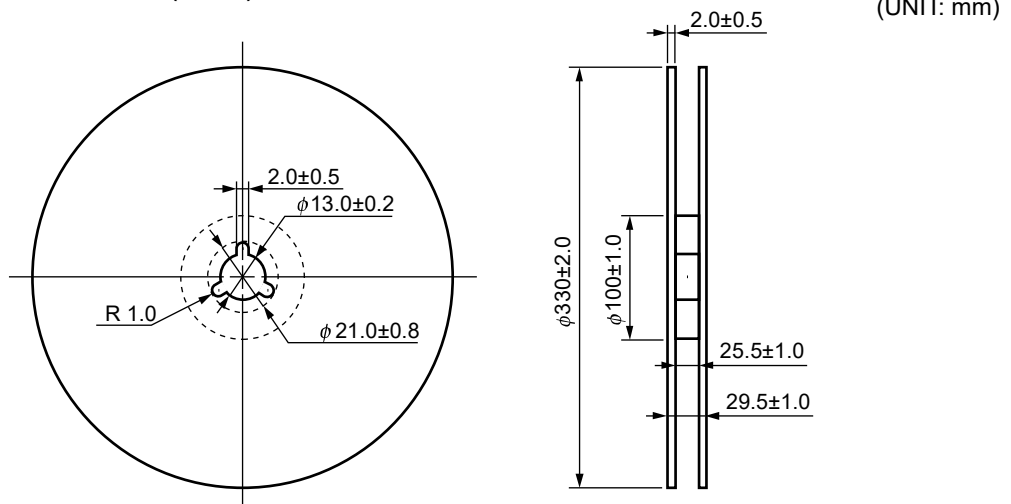

Packing: 2 000 pcs/reel

RECOMMENDED MOUNT PAD DIMENSIONS (UNIT: mm)

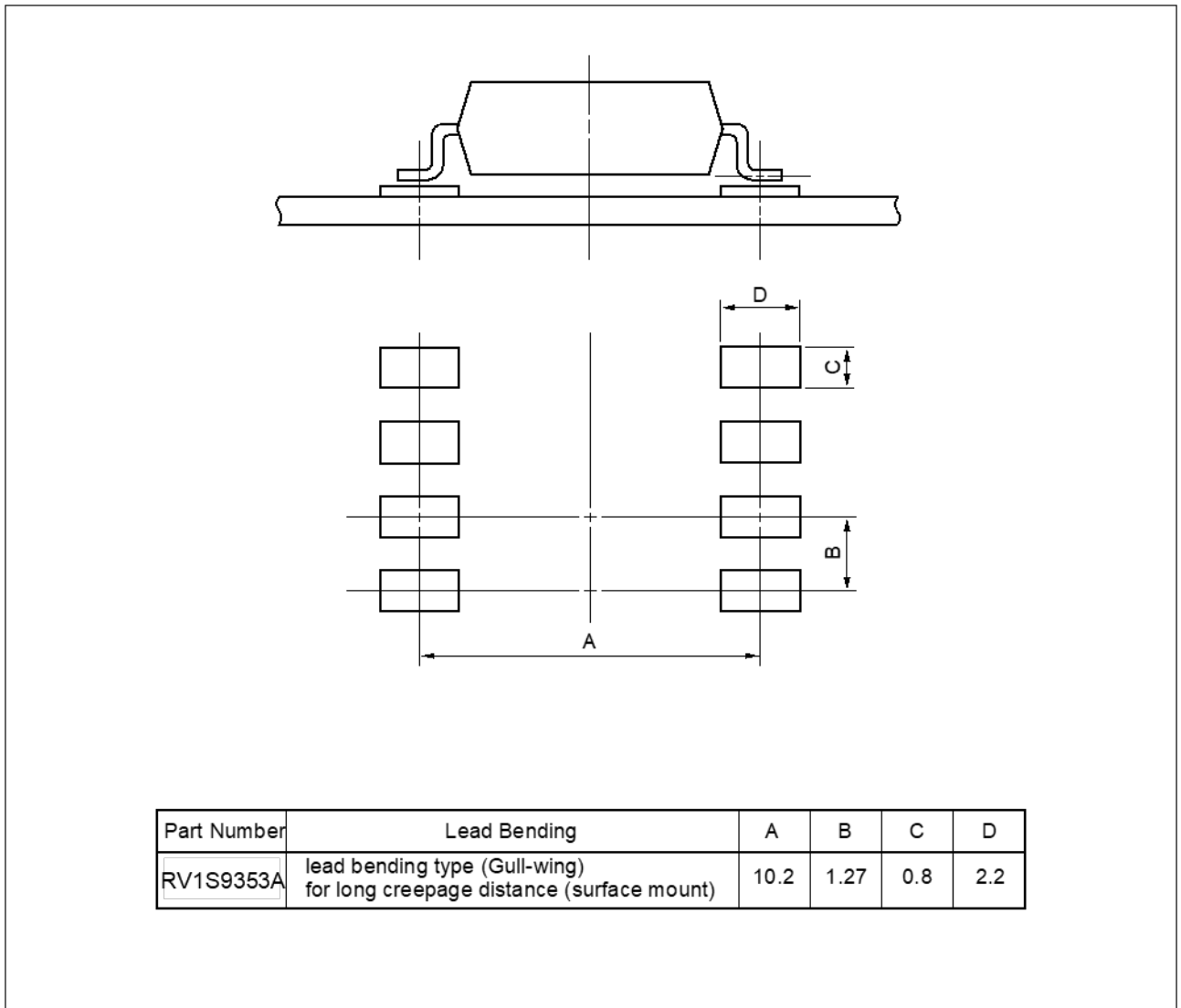

Remark All dimensions in this figure must be evaluated before use.

NOTES ON HANDLING

1. Recommended soldering conditions

(1) Infrared reflow soldering

- Peak reflow temperature 260°C or below (package surface temperature)
- Time of peak reflow temperature 10 seconds or less
- Time of temperature higher than 220°C 60 seconds or less
- Time to preheat temperature from 120 to 180°C 120±30 s
- Number of reflows Three
- Flux Rosin flux containing small amount of chlorine (The flux with a maximum chlorine content of 0.2 Wt% is recommended.)

Recommended Temperature Profile of Infrared Reflow

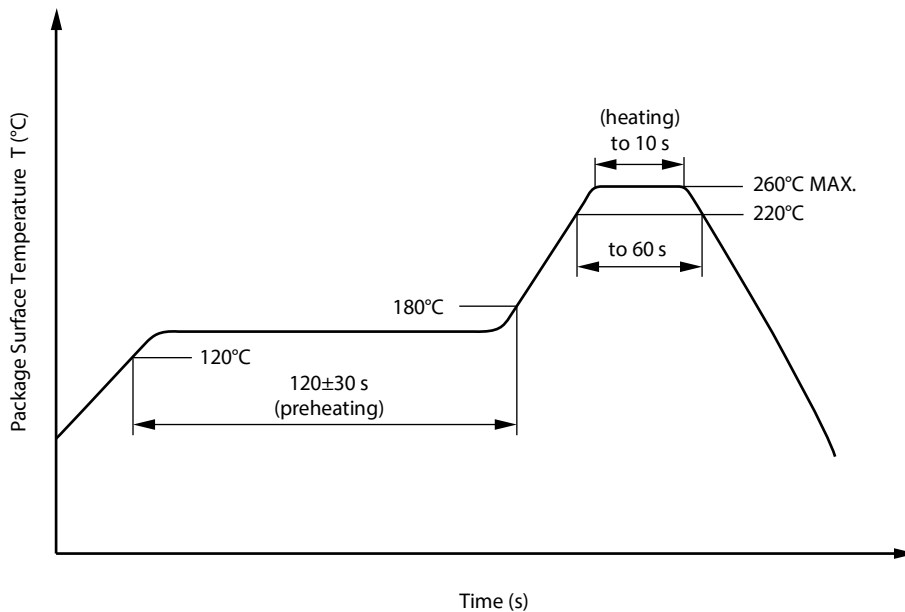

(2) Wave soldering

- Temperature 260°C or below (molten solder temperature)
- Time 10 seconds or less
- Preheating conditions 120°C or below (package surface temperature)
- Number of times One (Allowed to be dipped in solder including plastic mold portion.)
- Flux Rosin flux containing small amount of chlorine (The flux with a maximum chlorine content of 0.2 Wt% is recommended.)

(3) Soldering by Soldering Iron

- Peak Temperature (lead part temperature) 350°C or below
 - Time (each pins) 3 seconds or less
 - Flux Rosin flux containing small amount of chlorine
(The flux with a maximum chlorine content of 0.2 Wt% is recommended.)
- (a) Soldering of leads should be made at the point 1.5 to 2.0 mm from the root of the lead
 (b) Please be sure that the temperature of the package would not be heated over 100°C

(4) Cautions

- Flux Cleaning
Avoid cleaning with Freon based or halogen-based (chlorinated etc.) solvents.
- Do not use fixing agents or coatings containing halogen-based substances.

2. Cautions regarding noise

Be aware that when voltage is applied suddenly between the photocoupler's input and output at startup, the output transistor may enter the on state, even if the voltage is within the absolute maximum ratings.

USAGE CAUTIONS

1. This product is weak for static electricity by designed with high-speed integrated circuit so protect against static electricity when handling.
2. Board designing
 - (1) Below figure shows a typical application circuit where the RV1S9353A is used. A digital filter (Sinc³ filter) reduces high frequency quantization noise from the RV1S9353A and converts from one-bit data stream to 3-wire serial data.

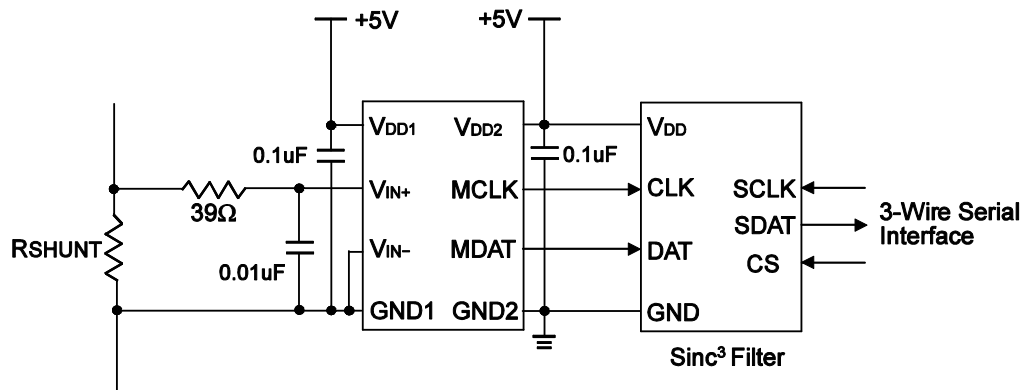

Fig. RV1S9353A Typical application circuit

- (2) By-pass capacitor of more than 0.1 μF is used between V_{DD} and GND near device. Also, ensure that the distance between the leads of the photocoupler and capacitor is no more than 10 mm.
 - (3) Keep the pattern connected the input ($V_{\text{IN}+}$, $V_{\text{IN}-}$) and the output (MCLK, MDAT), respectively, as short as possible. MCLK and MDAT are digital signal, but when the lines between the photocoupler and a digital filter are long, the digital filter might not read the data.
When using long lines, use a line driver between the photocoupler and the digital filter, and keep the pattern between the output (MCLK, MDAT) and the line driver as short as possible.
 - (4) Do not connect any routing to the portion of the frame exposed between the pins on the package of the photocoupler. If connected, it will affect the photocoupler's internal voltage and the photocoupler will not operate normally.
 - (5) Because the maximum frequency of the signal input to the photocoupler must be lower than the allowable frequency band, be sure to connect an anti-aliasing filter (an RC filter with $R = 39 \Omega$ and $C = 0.01 \mu\text{F}$, for example).
 - (6) When $V_{\text{DD}1}$ is lower than 4.5 V that is the outside of the recommended operating condition, the output (MCLK, MDAT) of this product is unstable, and this might produce undesirable operation. Be sure to check the operation of an IC that is connected to this product during Power-up and Power-down process. And we recommend to use a disable function (shutdown function) of the connected IC or a reset IC to avoid this undesirable operation.
3. Avoid storage at a high temperature and high humidity.

SPECIFICATION OF VDE MARKS LICENSE DOCUMENT

Parameter	Symbol	Spec.	Unit
Climatic test class (IEC 60068-1/DIN EN 60068-1)		40/110/21	
Dielectric strength maximum operating isolation voltage	U_{IORM}	1 500	V_{peak}
Test voltage (partial discharge test, procedure a for type test and random test) $U_{pr} = 1.6 \times U_{IORM}, P_d < 5 \text{ pC}$	U_{pr}	2 400	V_{peak}
Test voltage (partial discharge test, procedure b for all devices) $U_{pr} = 1.875 \times U_{IORM}, P_d < 5 \text{ pC}$	U_{pr}	2 813	V_{peak}
Highest permissible overvoltage	UTR	8 000	V_{peak}
Degree of pollution (IEC 60664-1/DIN EN 60664-1 (VDE 0110-1))		2	
Comparative tracking index (IEC 60112/DIN EN 60112 (VDE 0303 Part 11))	CTI	175	
Material group (IEC 60664-1/DIN EN 60664-1 (VDE 0110-1))		III a	
Storage temperature range	T_{stg}	-55 to +150	°C
Operating temperature range	T_A	-40 to +110	°C
Isolation resistance, minimum value $V_{IO} = 500 \text{ V dc at } T_A = 25^\circ\text{C}$ $V_{IO} = 500 \text{ V dc at } T_A \text{ MAX. at least } 100^\circ\text{C}$	Ris MIN. Ris MIN.	10^{12} 10^{11}	Ω Ω
Safety maximum ratings (maximum permissible in case of fault, see thermal derating curve) Package temperature Current (input current I_F , $P_{si} = 0$) Power (output or total power dissipation) Isolation resistance $V_{IO} = 500 \text{ V dc at } T_A = T_{si}$	T_{si} I_{si} P_{si} Ris MIN.	175 400 700 10^9	°C mA mW Ω

Dependence of maximum safety ratings with package temperature

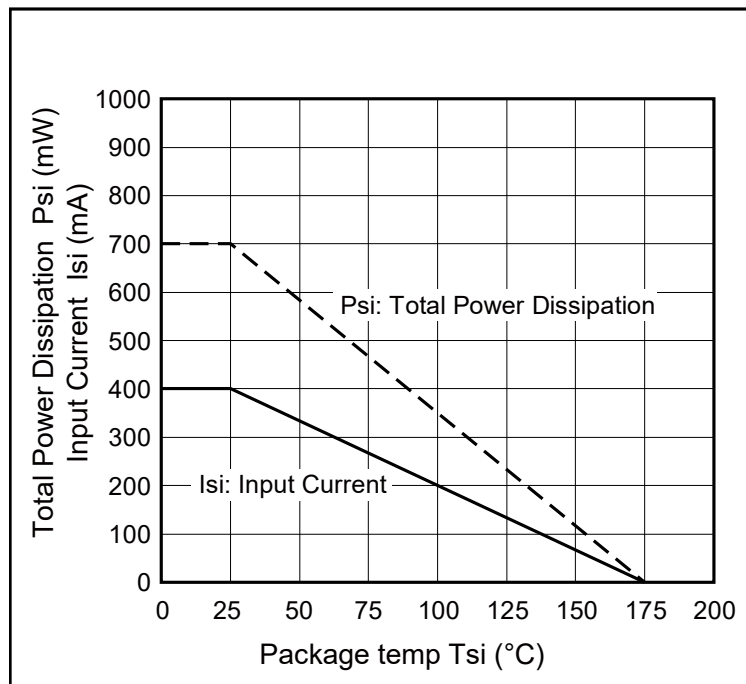

Method a Destructive Test, Type and Sample Test

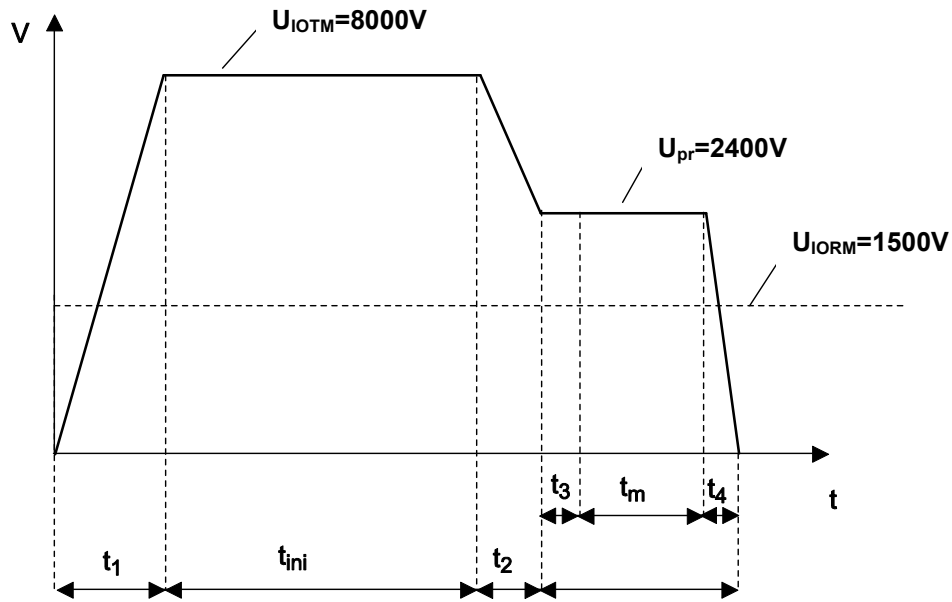

$t_1, t_2 = 1 \text{ to } 10 \text{ sec}$
 $t_3, t_4 = 1 \text{ sec}$
 $t_m(\text{PARTIAL DISCHARGE}) = 10 \text{ sec}$
 $t_{test} = 12 \text{ sec}$
 $t_{ini} = 60 \text{ sec}$

Method b Non-destructive Test, 100% Production Test

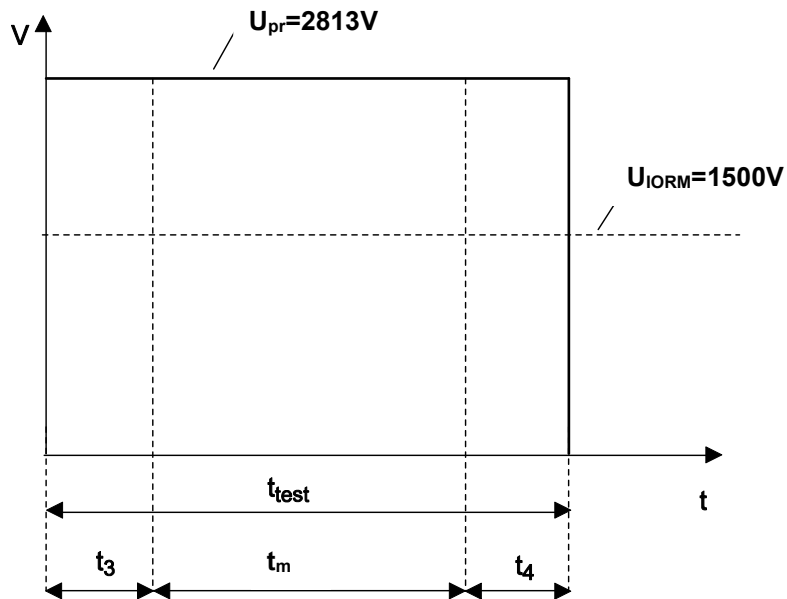

$t_3, t_4 = 0.1 \text{ sec}$
 $t_m(\text{PARTIAL DISCHARGE}) = 1.0 \text{ sec}$
 $t_{test} = 1.2 \text{ sec}$

Caution GaAs Products	<p>This product uses gallium arsenide (GaAs). GaAs vapor and powder are hazardous to human health if inhaled or ingested, so please observe the following points.</p> <ul style="list-style-type: none">• Follow related laws and ordinances when disposing of the product. If there are no applicable laws and/or ordinances, dispose of the product as recommended below.<ol style="list-style-type: none">1. Commission a disposal company able to (with a license to) collect, transport and dispose of materials that contain arsenic and other such industrial waste materials.2. Exclude the product from general industrial waste and household garbage, and ensure that the product is controlled (as industrial waste subject to special control) up until final disposal.• Do not burn, destroy, cut, crush, or chemically dissolve the product.• Do not lick the product or in any way allow it to enter the mouth.
------------------------------	--

All trademarks and registered trademarks are the property of their respective owners.