

RV1S9960A

R08DS0169EJ0200

Rev.2.00

Jun. 30, 2021

HIGH CMR, 15Mbps CMOS OUTPUT, LOW FORWARD-CURRENT(I_F) 3.3V/5V OPERATION,
15 mm LONG-CREEPAGE 8-PIN LSDIP

DESCRIPTION

The RV1S9960A is a photocoupler featuring high-speed switching up to 15Mbps with active low output logic which consist of an AlGaAs LED on the input side and an integrated circuit with a photodiode on the output.

This product enables to low current operation on 3.3V/5V power supply with high noise-tolerant CMR:50kV/us min. and high temperature operation up to T_A = 110°C in logic interface circuit.

FEATURES

- Long creepage distance (15 mm MIN)
- High speed communication (15 Mbps)
- High temperature operation (-40 to +110 °C)
- High common mode (dv/dt) tolerant (CM_H, CM_L = ± 50 kV/μs MIN.)
- High isolation voltage (BV = 7 500 Vr.m.s.)
- Low input drive current (I_{FHL} = 3.8 mA MAX.)
- Low voltage power supply operation (V_{DD} = 2.7 V ~ 5.5 V)
- Low pulse width distortion (PWD = 20 ns MAX.)
- Ordering number of tape product :
RV1S9960ACCSP-10Yx#KC0 : 1 000 pcs/reel
- Pb free product
- Safety standards approval
UL : UL1577, Double protection
CSA : CAN/CSA-C22.2 No.62368-1, Reinforced insulation
VDE : DIN EN 60747-5-5 (Option)

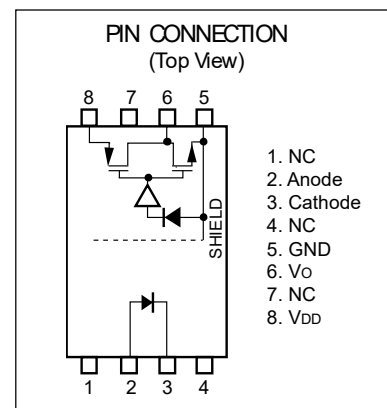

TRUTH TABLE

LED	OUTPUT
ON	L
OFF	H

APPLICATIONS

- Industrial Inverter
- Solar Inverter
- Power Conditioner

Start of mass production

Jun.2019

PACKAGE DIMENSIONS (UNIT : mm)

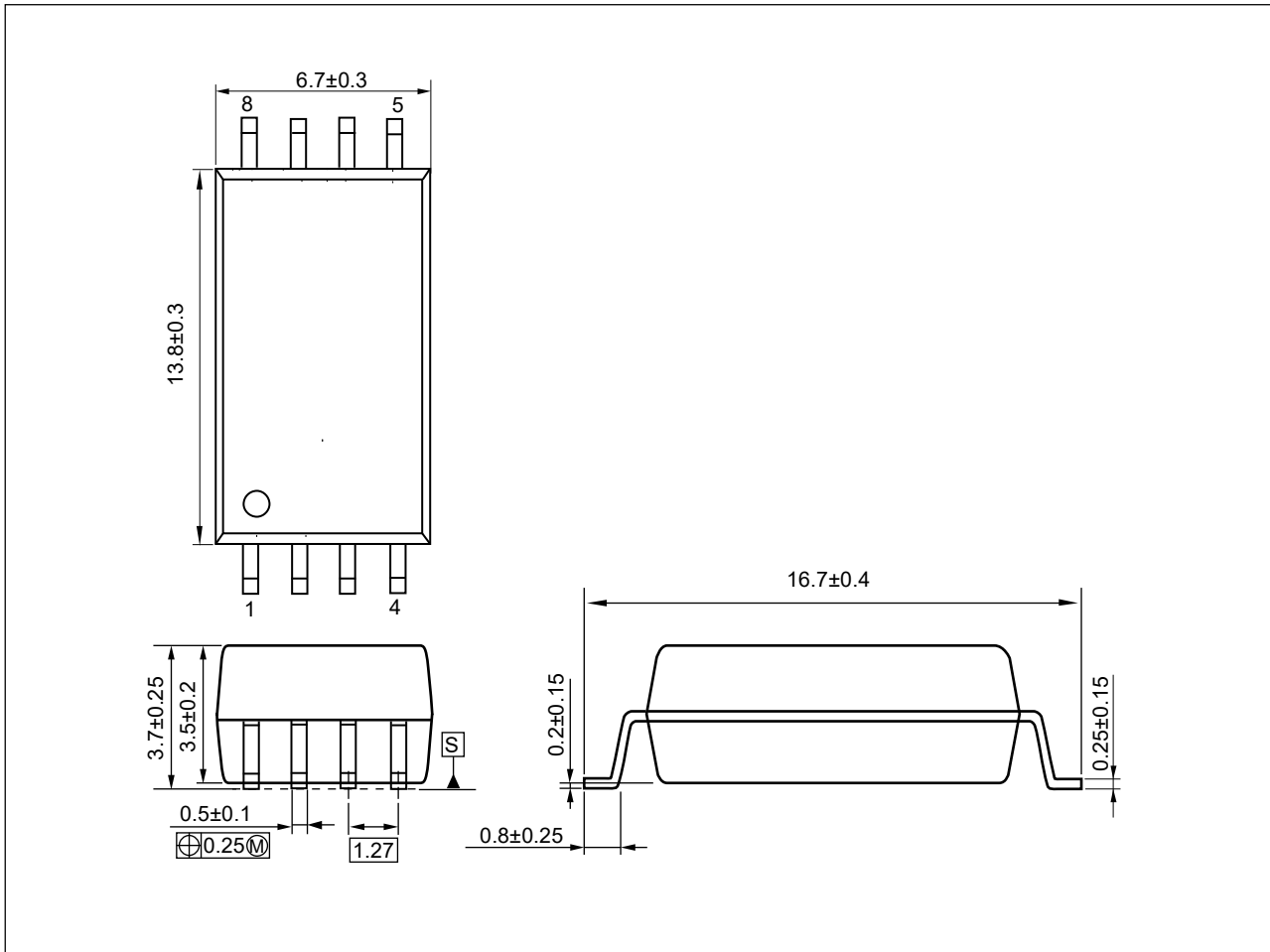

Weight : 0.642g (typ.)

PHOTOCOUPLER CONSTRUCTION

Parameter	MIN.
Air Distance	14.5 mm
Creepage Distance	15 mm
Isolation Distance	0.4 mm

MARKING EXAMPLE

No. 1 pin Mark

R
9960
N131

← Company Initial
← Type Number *
← Assembly Lot

N 1 31
Rank Code
Year Assembled (Last 1 Digit)
Week Assembled

*Applicable type numbers are listed below.

*1) RV1S 9960 ACCSP-10Yx

Marking type number. "RV1S" and "ACCSP-10Yx" are omitted from original type number.

ORDERING INFORMATION

Part Number	Order Number	Solder Plating Specification	Packing Style	Safety Standard Approval	Application Part Number*1
RV1S9960ACCSP-10YC	RV1S9960ACCSP-10YC#SC0	Pb-Free and Halogen Free (Ni/Pd/Au)	10 pcs (Tape 10 pcs cut)	Standard products (UL, CSA approved)	RV1S9960A
	RV1S9960ACCSP-10YC#KC0		Embossed Tape 1 000 pcs/reel		
RV1S9960ACCSP-10YV	RV1S9960ACCSP-10YV#SC0		10 pcs (Tape 10 pcs cut)	UL, CSA, DIN EN 60747-5-5 approved	
	RV1S9960ACCSP-10YV#KC0		Embossed Tape 1 000 pcs/reel		

Notes: *1. For the application of the Safety Standard, following part number should be used.

ABSOLUTELY MAXIMUM RATINGS (T_A = 25 °C, unless otherwise specified)

Parameter		Symbol	Ratings	Unit
Diode	Forward Current	I _F	20	mA
	Reverse Voltage	V _R	5	V
Detector	Supply Voltage	V _{DD}	6	V
	Output Voltage	V _O	6	V
	Output Current	I _O	10	mA
	Power Dissipation *1	P _C	250	mW
Isolation Voltage *2		BV	7 500	Vr.m.s.
Operating Ambient Temperature		T _A	-40 to +110	°C
Storage Temperature		T _{stg}	-55 to +125	°C

Notes: 1. Reduced to 5.0 mW/°C at T_A = 85 °C or more
 2. AC Voltage for 1minite at T_A = 25 °C, RH = 60 % between input and output.
 Pins 1-4 shorted together, 5-8 shorted together.

RECOMMENDED OPERATING CONDITIONS

Parameter	Symbol	MIN.	TYP.	MAX.	Unit
Low Level forward voltage	V_{FL}	0		0.8	V
High Level Forward Current	I_{FH}	5		8	mA
Supply Voltage	V_{DD}	2.7		5.5	V

ELECTRICAL CHARACTERISTICS

(T_A = -40 to +110 °C, V_{DD} = 2.7 to 5.5 V, unless otherwise specified)

Parameter		Symbol	Conditions	MIN.	TYP.*1	MAX.	Unit	
Diode	Forward Voltage	V_F	$I_F = 6 \text{ mA}$, T _A = 25 °C	1.4	1.55	1.7	V	
	Reverse Current	I_R	$V_R = 3 \text{ V}$, T _A = 25 °C			10	μA	
	Terminal Capacitance	C_t	$V_F = 0 \text{ V}$, f = 1 MHz, T _A = 25 °C		30		pF	
Detector	High Level Output Current	I_{DDH}	$I_F = 0 \text{ mA}$		1.1	2	mA	
	Low Level Output Current	I_{DDL}	$I_F = 5 \text{ mA}$		1.0	2	mA	
	High Level Output Voltage	V_{OH}	$I_O = -3.2 \text{ mA}$, $I_F = 0 \text{ mA}$	$V_{DD-1.0}$	V_{DD}		V	
			$I_O = -20 \text{ μA}$, $I_F = 0 \text{ mA}$	$V_{DD-0.1}$	V_{DD}			
	Low Level Output Voltage	V_{OL}	$I_O = 3.2 \text{ mA}$, $I_F = 5 \text{ mA}$		0.13	0.4	V	
$I_O = 20 \text{ μA}$, $I_F = 5 \text{ mA}$				0.001	0.1			
Coupled	Threshold Input Voltage (H to L)	I_{FHL}	$V_O < 0.4 \text{ V}$		1.8	3.8	mA	
	Isolation Resistance	R_{I-O}	$V_{I-O} = 1 \text{ kV}_{DC}$, RH = 40 to 60 %, T _A = 25 °C	10^{11}			Ω	
	Isolation Capacitance	C_{I-O}	$V = 0 \text{ V}$, f = 1 MHz, T _A = 25 °C		0.6		pF	
	Propagation Delay Time (H to L) ^{*2}	t_{PHL}	$I_F = 5 \text{ mA} \leftrightarrow 0 \text{ mA}$ $V_{DD} = 3.3 \text{ V}, 5 \text{ V}$ $C_L = 15 \text{ pF}$		36	60	ns	
					38	60		
	Propagation Delay Time (L to H) ^{*2}	t_{PLH}			2	20		
	Pulse Width Distortion ^{*2}	PWD				25		
	Propagation Delay Skew	t_{PSK}			5			
	Rise Time	t_r			5			
	Fall Time	t_f						
Common Mode Transient Immunity at High Level Output ^{*3}	$ CM_H $	$I_F = 0 \text{ mA}$, $V_O > 4 \text{ V}$ ($V_{DD} = 5 \text{ V}$), $V_O > 2.3 \text{ V}$ ($V_{DD} = 3.3 \text{ V}$), $V_{CM} = 1.5 \text{ kV}$, T _A = 25 °C		50	60			kV/μs
Common Mode Transient Immunity at Low Level Output ^{*3}	$ CM_L $	$I_F = 5 \text{ mA}$, $V_O < 0.4 \text{ V}$ ($V_{DD} = 3.3 \text{ V}, 5 \text{ V}$), $V_{CM} = 1.5 \text{ kV}$, T _A = 25 °C		50	60			

- Note2: 1. Typical values at $T_A = 25\text{ }^\circ\text{C}$
 2. Test circuit for propagation delay time measurement

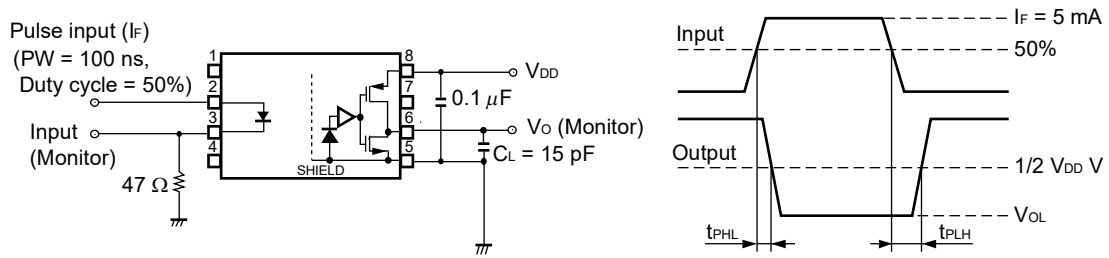

Remark C_L includes probe and stray wiring capacitance.

3. Test circuit for common mode transient immunity measurement

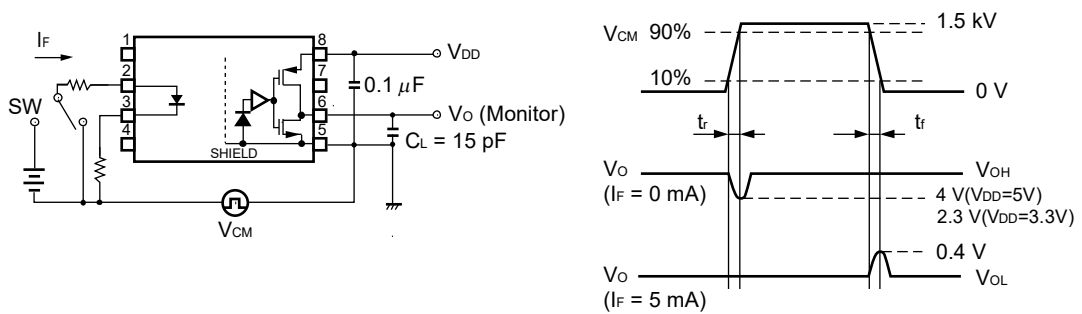

Remark C_L includes probe and stray wiring capacitance.

USAGE CAUTIONS

1. This product is weak for static electricity by designed with high-speed integrated circuit so protect against static electricity when handling.
2. By-pass capacitor of more than $0.1\text{ }\mu\text{F}$ is used between V_{DD} and GND near device. Also, ensure that the distance between the leads of the photocoupler and capacitor is no more than 10 mm.
3. Pin 1, 4 (which is an NC*1 pin) can either be connected directly to the GND pin on the LED side or left open. Also, Pin 7 (which is an NC*1 pin) can either be connected directly to the GND pin on the detector side or left open.
 Unconnected pins should not be used as a bypass for signals or for any other similar purpose because this may degrade the internal noise environment of the device.
 Note: *1. NC: Non-Connection (No Connection).
4. Avoid storage at a high temperature and high humidity.

TYPICAL CHARACTERISTICS (TA = 25 °C, unless otherwise specified)

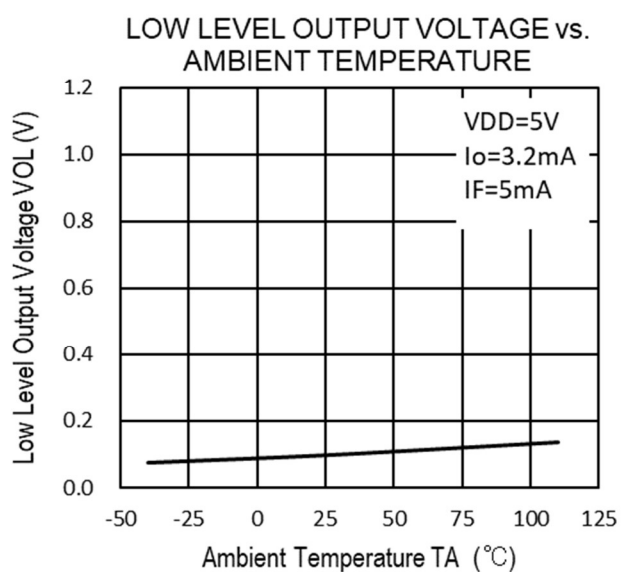
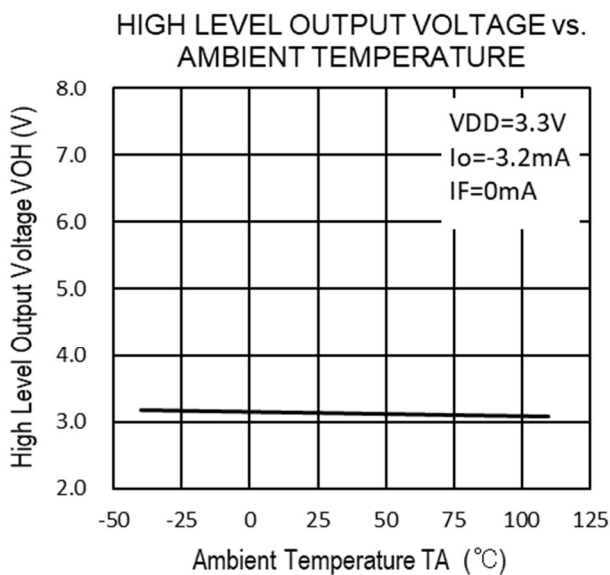
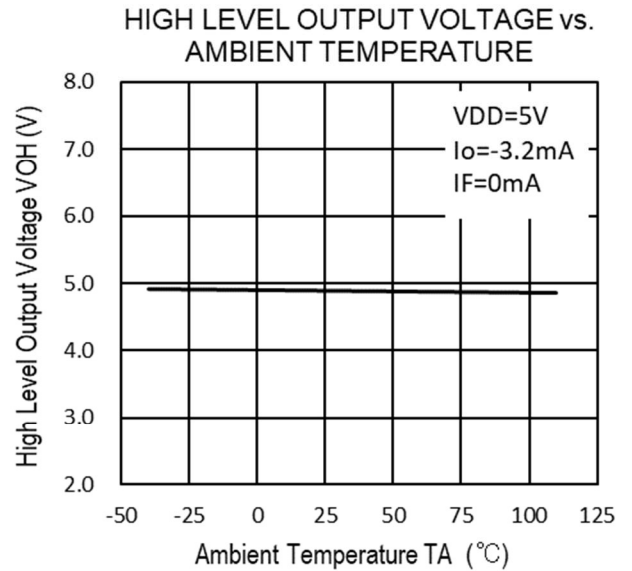
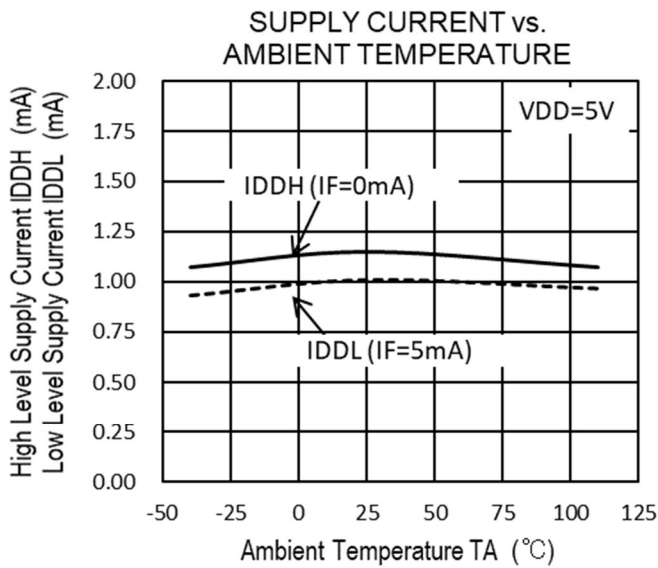
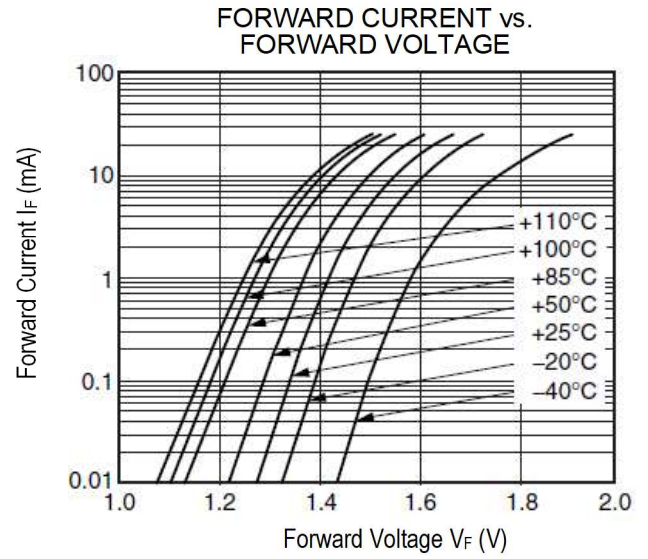
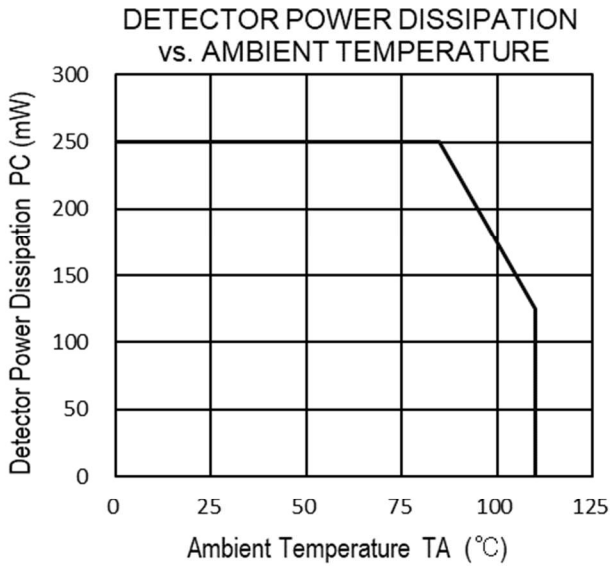

Remark The graphs indicate nominal characteristics.

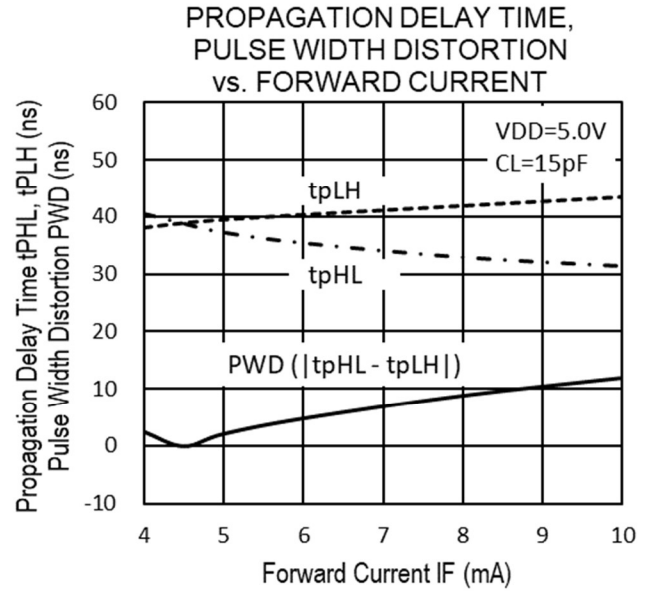
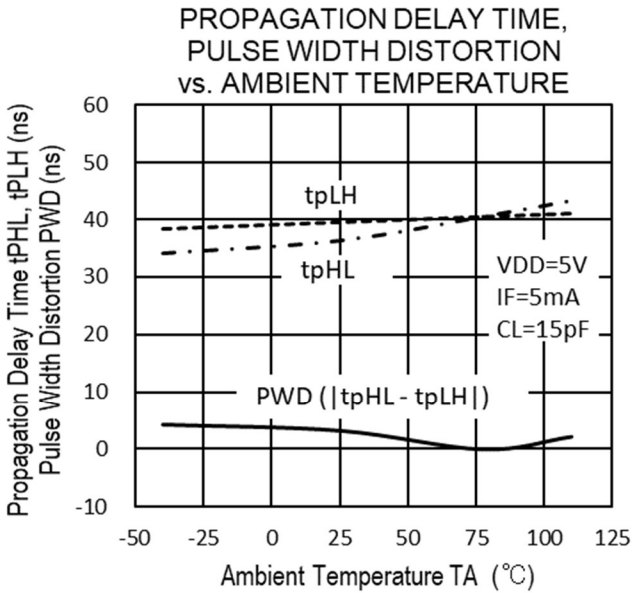
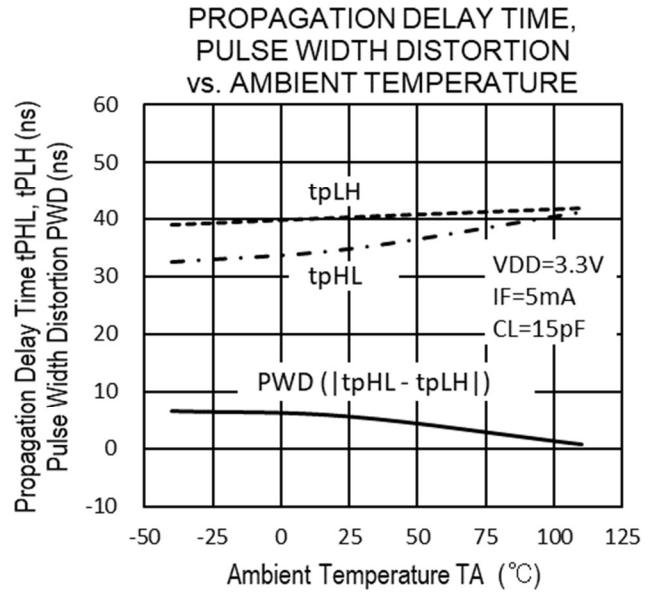
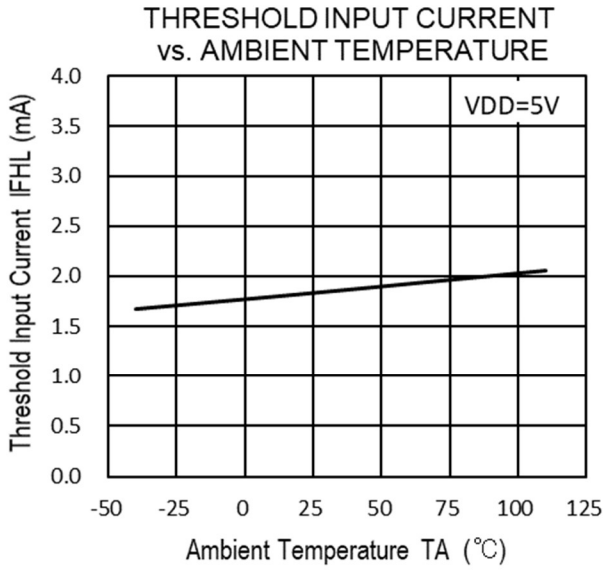

Remark The graphs indicate nominal characteristics.

TAPING SPECIFICATIONS (UNIT : mm)

Taping Direction

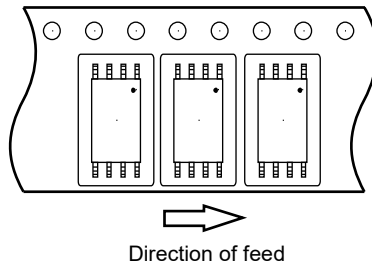

Outline and Dimensions (Tape)

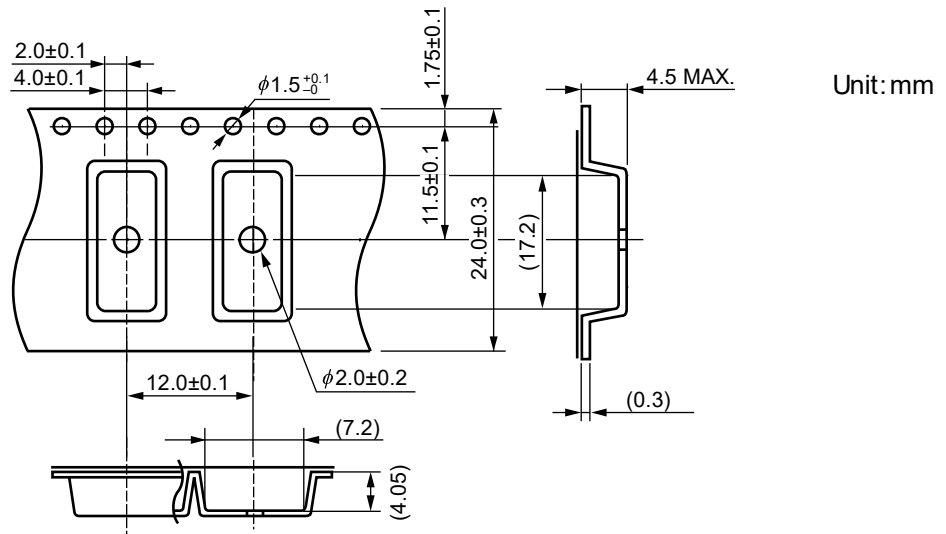

Unit: mm

Outline and Dimensions (Reel)

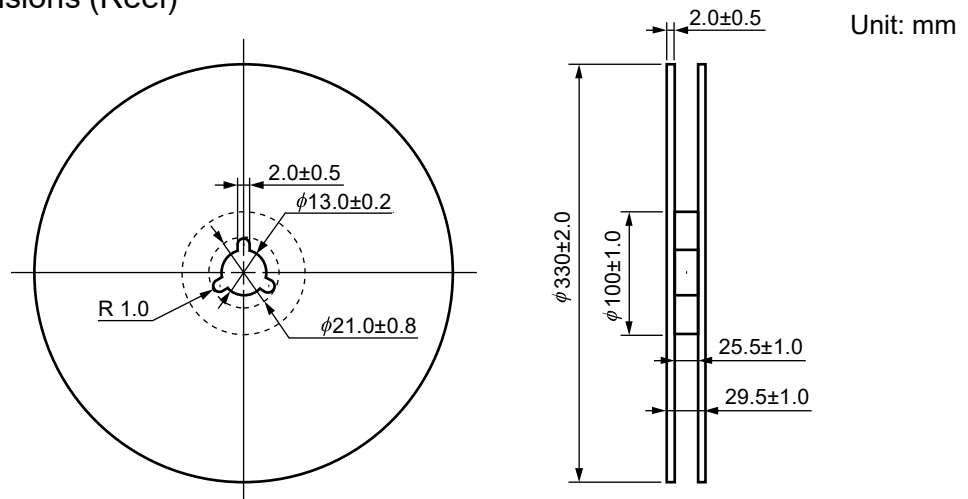

Unit: mm

Packing: 1 000 pcs/reel

RECOMMENDED MOUNT PAD DIMENSIONS (UNIT : mm)

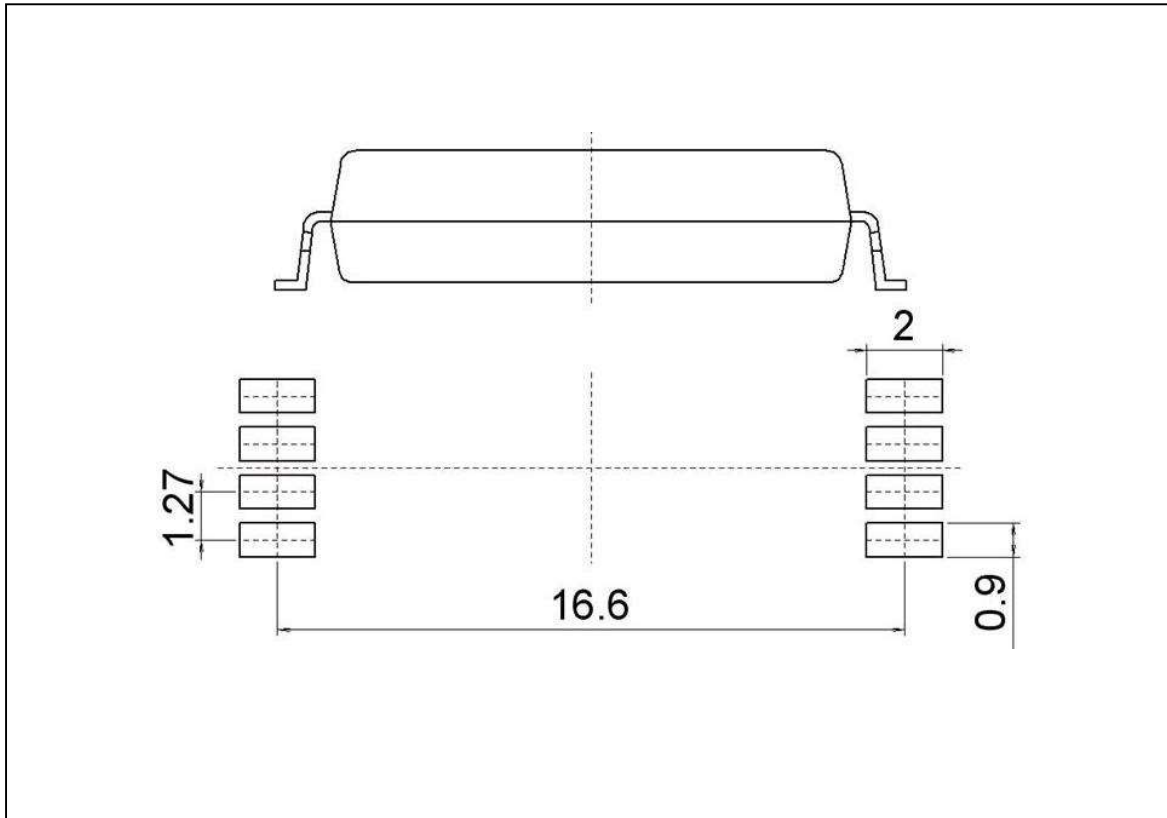

【8pin LSDIP】

Remark All dimensions in this figure must be evaluated before use.

NOTES ON HANDLING

1. Recommended soldering conditions

(1) Infrared reflow soldering

- Peak reflow temperature 260 °C or below (package surface temperature)
- Time of peak reflow temperature 10 seconds or less
- Time of temperature higher than 220 °C 60 seconds or less
- Time to preheat temperature from 120 to 180 °C 120 ± 30 s
- Number of reflows Three
- Flux Rosin flux containing small amount of chlorine
(The flux with a maximum chlorine content of 0.2 Wt% is recommended.)

Recommended Temperature Profile of Infrared Reflow

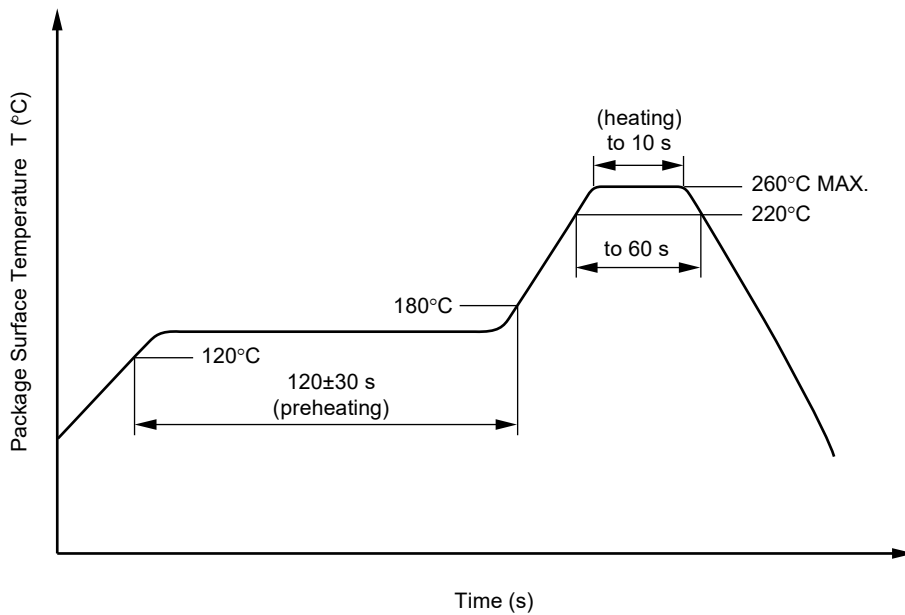

(2) Wave soldering

- Temperature 260 °C or below (molten solder temperature)
- Time 10 seconds or less
- Preheating conditions 120 °C or below (package surface temperature)
- Number of times One (Allowed to be dipped in solder including plastic mold portion.)
- Flux Rosin flux containing small amount of chlorine (The flux with a maximum chlorine content of 0.2 Wt% is recommended.)

(3) Soldering by Soldering Iron

- Peak Temperature (lead part temperature) 350 °C or below
- Time (each pins) 3 seconds or less
- Flux Rosin flux containing small amount of chlorine
(The flux with a maximum chlorine content of 0.2 Wt% is recommended.)

- (a) Soldering of leads should be made at the point 1.5 to 2.0 mm from the root of the lead
- (b) Please be sure that the temperature of the package would not be heated over 110 °C

(4) Cautions

- Flux Cleaning
Avoid cleaning with Freon based or halogen-based (chlorinated etc.) solvents.
- Do not use adhesives or coating materials including halogens to fix this device.

2. Cautions regarding noise

Be aware that when voltage is applied suddenly between the photocoupler's input and output or between V_{DD}-GND at startup, the output transistor may enter the on state, even if the voltage is within the absolute maximum ratings.

SPECIFICATION OF VDE MARKS LICENSE DOCUMENT

Parameter	Symbol	Rating	Unit
Climatic test class (IEC 60068-1/DIN EN 60068-1)		40/110/21	
Dielectric strength maximum operating isolation voltage	U_{IORM}	1 600	V_{peak}
Test voltage (partial discharge test, procedure a for type test and random test) $U_{pr} = 1.6 \times U_{IORM}, P_d < 5 \text{ pC}$	U_{pr}	2 560	V_{peak}
Test voltage (partial discharge test, procedure b for all devices) $U_{pr} = 1.875 \times U_{IORM}, P_d < 5 \text{ pC}$	U_{pr}	3 000	V_{peak}
Highest permissible overvoltage	U_{IOTM}	12 000	V_{peak}
Degree of pollution (IEC 60664-1/DIN EN 60664-1 (VDE 0110-1))		2	
Comparative tracking index (IEC 60112/DIN EN 60112 (VDE 0303-11))	CTI	175	
Material group (IEC 60664-1/DIN EN 60664-1 (VDE 0110-1))		III a	
Storage temperature range	T_{stg}	-55 to +125	°C
Operating temperature range	T_A	-40 to +110	°C
Isolation resistance, minimum value $V_{IO} = 500 \text{ V dc at } T_A = 25^\circ\text{C}$	Ris MIN.	10^{12}	Ω
$V_{IO} = 500 \text{ V dc at } T_A \text{ MAX. at least } 100^\circ\text{C}$	Ris MIN.	10^{11}	Ω
Safety maximum ratings (maximum permissible in case of fault, see thermal derating curve)			
Package temperature	T_{si}	175	°C
Current (input current I_F , $P_{si} = 0$)	I_{si}	400	mA
Power (output or total power dissipation)	P_{si}	700	mW
Isolation resistance $V_{IO} = 500 \text{ V dc at } T_A = T_{si}$	Ris MIN.	10^9	Ω

Dependence of maximum safety ratings with package temperature

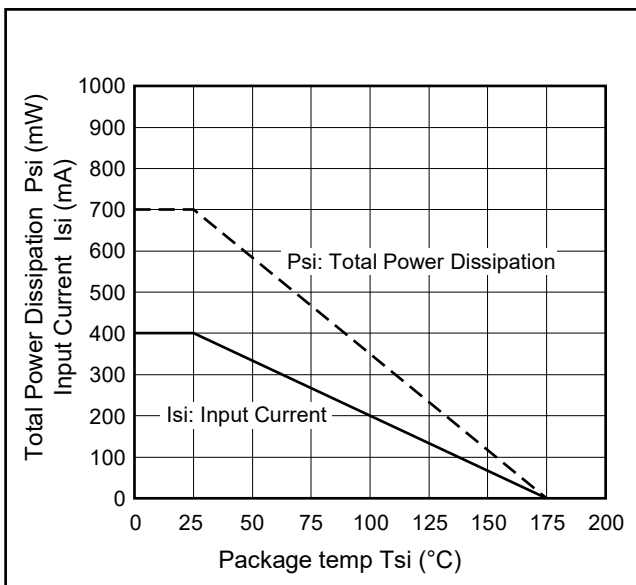

Method a Destructive Test, Type and Sample Test

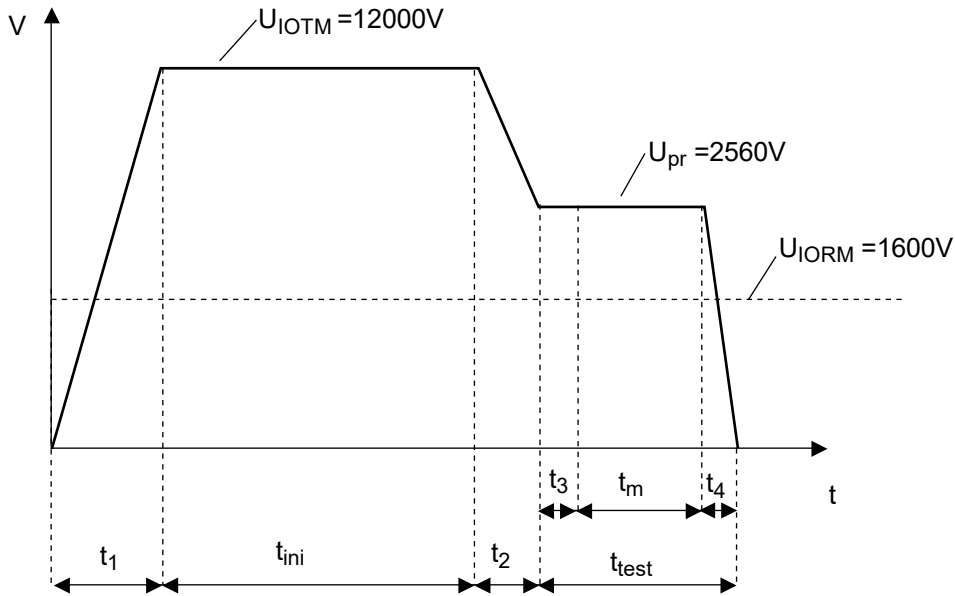

$t_1, t_2 = 1$ to 10 sec
 $t_3, t_4 = 1$ sec
 t_m (PARTIAL DISCHARGE) = 10 sec
 $t_{test} = 12$ sec
 $t_{ini} = 60$ sec

Method b Non-destructive Test, 100% Production Test

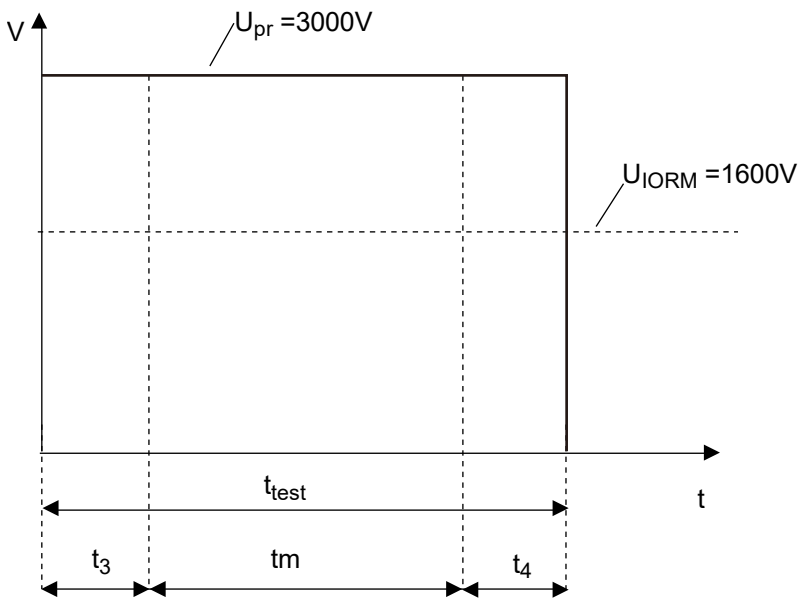

$t_3, t_4 = 0.1$ sec
 t_m (PARTIAL DISCHARGE) = 1.0 sec
 $t_{test} = 1.2$ sec

Caution	GaAs Products	<p>This product uses gallium arsenide (GaAs). GaAs vapor and powder are hazardous to human health if inhaled or ingested, so please observe the following points.</p> <ul style="list-style-type: none">• Follow related laws and ordinances when disposing of the product. If there are no applicable laws and/or ordinances, dispose of the product as recommended below.<ol style="list-style-type: none">1. Commission a disposal company able to (with a license to) collect, transport and dispose of materials that contain arsenic and other such industrial waste materials.2. Exclude the product from general industrial waste and household garbage, and ensure that the product is controlled (as industrial waste subject to special control) up until final disposal.• Do not burn, destroy, cut, crush, or chemically dissolve the product.• Do not lick the product or in any way allow it to enter the mouth.
----------------	---------------	--

All trademarks and registered trademarks are the property of their respective owners.