

TD / TS Series Molded Case Circuit Breakers UL489 Listed

Molded Case Circuit Breaker



- 4 Frame Sizes
- Compact Design
- Thermal Magnetic
- 240, 480, 600VAC
- 3 Poles
- Up to 100kA Short Circuit Interrupting Capacity
- **Circuit Breakers are supplied with line and load terminals**
- HACR rated
- CE version (without UL approval) available upon request



SPECIFICATIONS

	Current Rating	Wire Ratings	Calibration Temperature
TD125	15-125A / 600V AC	60° / 75°C Cu only	40°C (104°F)
TS250	150-250A / 600V AC	60° / 75°C Cu only	
TS400	300-400A / 600V AC	75°C Cu only	
TS800	500-800A / 600V AC	75°C Cu only	

INTERRUPTING CAPACITY

	TD125		TS250		TS400		TS800	
	NU	HU	NU	HU	NU	HU	NU	HU
240V	50	100	50	100	50	100	50	100
480V	35	65	35	65	35	65	35	65
600V	10	14	10	18	14	20	18	25

TERMINAL SIZE ACCEPTABILITY AND TERMINAL TORQUE

Frame Types	Wire Range		Tightening Torque [lb.in.]
	Conductor Cross-section	Number of Conductors	
TD125 (15 - 125A)	14 - 8 AWG	1	60
	6 - 1/0 AWG	1	90
TS250 (150 - 250A)	1 AWG	1	150
	1/0 - 2/0 AWG	1	180
	3/0 - 4/0 AWG	1	250
	300 - 400 kcmil	1	325
TS400 (300 - 400A)	250 - 400 kcmil	1	325
	500 kcmil	1	375
	3/0 AWG	2	250
TS800 (500 - 600A)	250 - 500 kcmil	up to 2	375
TS800 (700 - 800A)	300 - 500 kcmil	up to 2	500
	300 - 400 kcmil	up to 3	500

TRIP CHARACTERISTICS

FTU	Fixed-Thermal Fixed-Magnetic	Rated current <i>See trip curve pages 76-77</i>
FMU	Adjustable-Thermal Fixed-Magnetic	0.8 - 1 x current adjustable <i>See trip curve pages 76-77</i>
ATU	Adjustable-Thermal Adjustable-Magnetic	0.8 - 1 x current adjustable 5 - 10 x current adjustable

PART NUMBERING SYSTEM

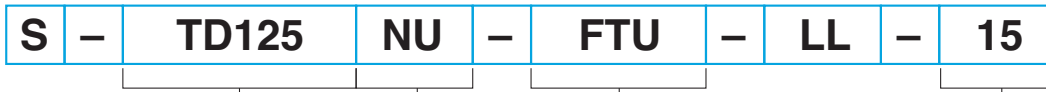

Frame Type

- TD125: 15-125A
- TS250: 150-250A
- TS400: 300-400A
- TS800: 500-800A

Interrupting Type

- NU, HU
- See page 66

Trip Type

- FTU, FMU, ATU

Rated Current (A)

- 15, 20, ..., 800

DIMENSIONS

Dimensions Frame types	Basic Dimensions W x H x D [inch/mm]
TD125	3.54 x 6.46 x 3.39/90 x 164 x 86
TS250	4.13 x 7.01 x 3.39/105 x 178 x 86
TS400	5.51 x 11.5 x 4.33/140 x 292 x 110
TS800	8.27 x 16.85 x 5.31/210 x 428 x 135

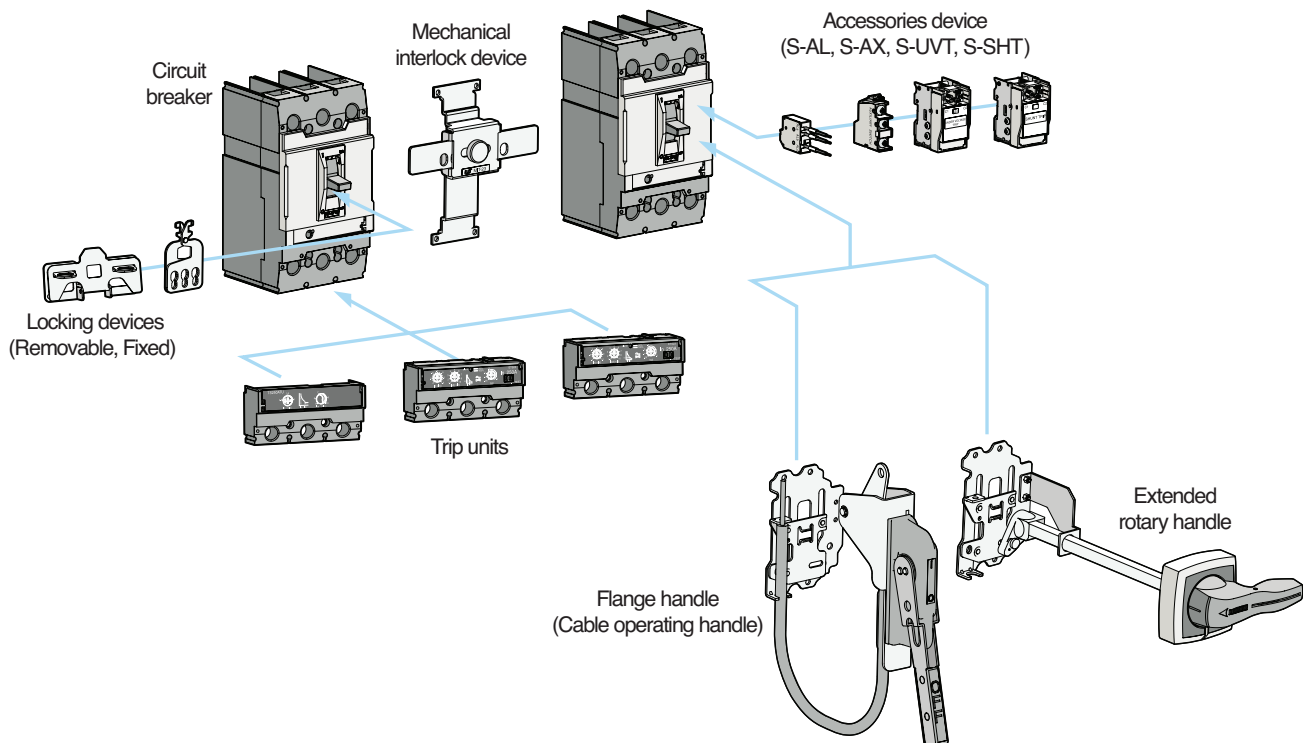
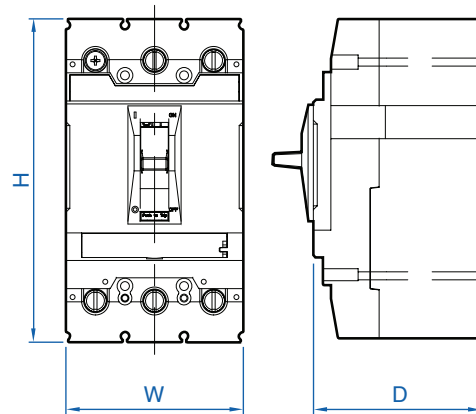

TD / TS Series Circuit Breakers

Normal Interrupting
Capacity (NU)

Circuit Breakers are supplied with line and load terminals

Interrupting Capacity

	TD125	TS250	TS400	TS800
240V	50	50	50	50
480V	35	35	35	35
600V	10	10	14	18

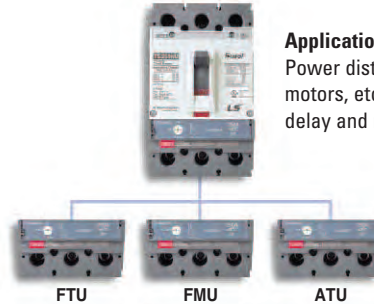

Application Examples:

Power distribution, power generation, motors, etc. Relatively short thermal trip delay and medium magnetic trip point.

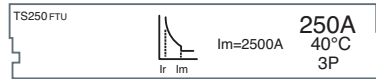

FTU

Fixed-thermal,
Fixed-magnetic

Rated Current	Type/ Cat. No.
15A	S-TD125NU-FTU-LL-15
20A	S-TD125NU-FTU-LL-20
30A	S-TD125NU-FTU-LL-30
40A	S-TD125NU-FTU-LL-40
50A	S-TD125NU-FTU-LL-50
60A	S-TD125NU-FTU-LL-60
80A	S-TD125NU-FTU-LL-80
100A	S-TD125NU-FTU-LL-100
125A	S-TD125NU-FTU-LL-125
150A	S-TS250NU-FTU-LL-150
160A	S-TS250NU-FTU-LL-160
175A	S-TS250NU-FTU-LL-175
200A	S-TS250NU-FTU-LL-200
225A	S-TS250NU-FTU-LL-225
250A	S-TS250NU-FTU-LL-250
300A	S-TS400NU-FTU-LL-300
350A	S-TS400NU-FTU-LL-350
400A	S-TS400NU-FTU-LL-400
500A	S-TS800NU-FTU-LL-500
600A	S-TS800NU-FTU-LL-600
700A	S-TS800NU-FTU-LL-700
800A	S-TS800NU-FTU-LL-800

Standard Pack: 1

Weight:

TD125: 2.65 lb. TS400: 12.57 lb.
TS250: 4.19 lb. TS800: 29.98 lb.

Accessories (see pages 70-72)

Dimensions (see pages 73-75)

Trip Curves (see pages 76-77)

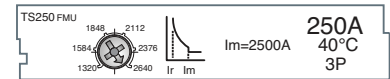

FMU*

Adjustable-
thermal, Fixed-
magnetic

Rated Current	Type/ Cat. No.
40A	S-TD125NU-FMU-LL-40
50A	S-TD125NU-FMU-LL-50
60A	S-TD125NU-FMU-LL-60
80A	S-TD125NU-FMU-LL-80
100A	S-TD125NU-FMU-LL-100
125A	S-TD125NU-FMU-LL-125
160A	S-TS250NU-FMU-LL-160
200A	S-TS250NU-FMU-LL-200
250A	S-TS250NU-FMU-LL-250
300A	S-TS400NU-FMU-LL-300
400A	S-TS400NU-FMU-LL-400
500A	S-TS800NU-FMU-LL-500
600A	S-TS800NU-FMU-LL-600
800A	S-TS800NU-FMU-LL-800

Standard Pack: 1

Weight:

TD125: 2.65 lb. TS400: 12.57 lb.
TS250: 4.19 lb. TS800: 29.98 lb.

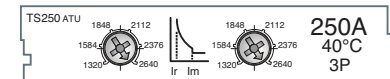

ATU*

Adjustable-
thermal,
Adjustable-
magnetic

Rated Current	Type/ Cat. No.
160A	S-TS250NU-ATU-LL-160
200A	S-TS250NU-ATU-LL-200
250A	S-TS250NU-ATU-LL-250
300A	S-TS400NU-ATU-LL-300
400A	S-TS400NU-ATU-LL-400
500A	S-TS800NU-ATU-LL-500
600A	S-TS800NU-ATU-LL-600
800A	S-TS800NU-ATU-LL-800

Standard Pack: 1

Weight:

TD125: 2.65 lb. TS400: 12.57 lb.
TS250: 4.19 lb. TS800: 29.98 lb.

* Not a stock item, please consult Altech for availability.

TD / TS Series Circuit Breakers

High Interrupting
Capacity (HU)

Circuit Breakers are supplied with line and load terminals

Interrupting Capacity

	TD125	TS250	TS400	TS800
240V	100	100	100	100
480V	65	65	65	65
600V	14	18	20	25

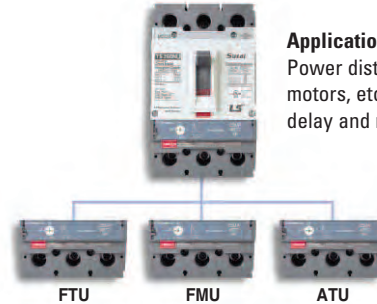

Application Examples:

Power distribution, power generation, motors, etc. Relatively short thermal trip delay and medium magnetic trip point.

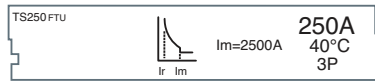

FTU
Fixed-thermal,
Fixed-magnetic

Rated Current	Type/ Cat. No.
15A	S-TD125HU-FTU-LL-15
20A	S-TD125HU-FTU-LL-20
30A	S-TD125HU-FTU-LL-30
40A	S-TD125HU-FTU-LL-40
50A	S-TD125HU-FTU-LL-50
60A	S-TD125HU-FTU-LL-60
80A	S-TD125HU-FTU-LL-80
100A	S-TD125HU-FTU-LL-100
125A	S-TD125HU-FTU-LL-125
150A	S-TS250HU-FTU-LL-150
160A	S-TS250HU-FTU-LL-160
175A	S-TS250HU-FTU-LL-175
200A	S-TS250HU-FTU-LL-200
225A	S-TS250HU-FTU-LL-225
250A	S-TS250HU-FTU-LL-250
300A	S-TS400HU-FTU-LL-300
350A	S-TS400HU-FTU-LL-350
400A	S-TS400HU-FTU-LL-400
500A	S-TS800HU-FTU-LL-500
600A	S-TS800HU-FTU-LL-600
700A	S-TS800HU-FTU-LL-700
800A	S-TS800HU-FTU-LL-800

Standard Pack: 1
Weight:

TD125: 2.65 lb. TS400: 12.57 lb.
TS250: 4.19 lb. TS800: 29.98 lb.

Accessories (see pages 70-72)
Dimensions (see pages 73-75)
Trip Curves (see pages 76-77)

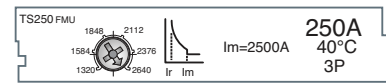

FMU*
Adjustable-thermal,
Fixed-magnetic

Rated Current	Type/ Cat. No.
40A	S-TD125HU-FMU-LL-40
50A	S-TD125HU-FMU-LL-50
60A	S-TD125HU-FMU-LL-60
80A	S-TD125HU-FMU-LL-80
100A	S-TD125HU-FMU-LL-100
125A	S-TD125HU-FMU-LL-125
160A	S-TS250HU-FMU-LL-160
200A	S-TS250HU-FMU-LL-200
250A	S-TS250HU-FMU-LL-250
300A	S-TS400HU-FMU-LL-300
400A	S-TS400HU-FMU-LL-400
500A	S-TS800HU-FMU-LL-500
600A	S-TS800HU-FMU-LL-600
800A	S-TS800HU-FMU-LL-800

Standard Pack: 1

Weight:
TD125: 2.65 lb. TS400: 12.57 lb.
TS250: 4.19 lb. TS800: 29.98 lb.

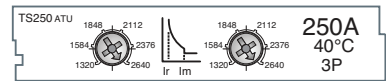

ATU*
Adjustable-
thermal,
Adjustable-
magnetic

Rated Current	Type/ Cat. No.
160A	S-TS250HU-ATU-LL-160
200A	S-TS250HU-ATU-LL-200
250A	S-TS250HU-ATU-LL-250
300A	S-TS400HU-ATU-LL-300
400A	S-TS400HU-ATU-LL-400
500A	S-TS800HU-ATU-LL-500
600A	S-TS800HU-ATU-LL-600
800A	S-TS800HU-ATU-LL-800

Standard Pack: 1

Weight:
TD125: 2.65 lb. TS400: 12.57 lb.
TS250: 4.19 lb. TS800: 29.98 lb.

* Not a stock item, please consult Altech for availability.

Accessories

Electrical Auxiliaries

Auxiliary Switch (S-AX), Alarm Switch (S-AL)

- Can be installed in all frame types

Contact Operation

MCCB	ON	OFF	TRIP	Cat. No.
Position of S-AX				S-AX
Position of S-AL				S-AL



Installation - see page 71

Technical Data

Conventional thermal current I_{th}	5A		
Rated operational current I_e with rated operational voltage U_e	Voltage	I_e (A)	
		Resistive Load	Inductive Load
- Alternating current 50/60Hz AC	125V	5	3
	250V	3	2
- Direct current DC	30V	4	3
	125V	0.4	0.4
	250V	0.2	0.2



Installation - see page 71

Shunt Release, S-SHT

- Can be installed in all frame types
- Range of operational voltage: 0.7 - 1.1 x V_n
- Frequency (only AC): 45Hz - 65Hz



Technical Data

	Control voltage (V)	Consumption			Cat. No.
		AC (VA)	DC (W)	mA	
Power consumption	DC 12V	-	0.36	30	S-SHT-12
	AC/DC 24V	0.58	0.58	24	S-SHT-24
	AC/DC 48V	1.22	1.23	25	S-SHT-48
	AC/DC 110~130V	1.36	1.37	10.5	S-SHT-120
	AC 220~240V/DC250V	1.80	1.88	7.5	S-SHT-230
	AC 380~500V	1.15	-	2.3	S-SHT-440
Max. opening time (msec)		50			
Tightening torque of terminal screw		7.1 lb.in.			

Installation - see page 71

Accessories

Electrical Auxiliaries

Undervoltage Release, S-UVT

- Can be installed in all frame types
- Reset-Hold Voltage = 0.85 x Vn
- Drop-Out Voltage = 0.35 - 0.7 x Vn
- Frequency (only AC): 45Hz - 65Hz



Technical Data

	Control voltage (V)	Consumption			Cat. No.
		AC (VA)	DC (W)	mA	
Power consumption	AC/DC 24V	0.64	0.65	27	S-UVT-24
	AC/DC 48V	1.09	1.10	23	S-UVT-48
	AC/DC 110~130V	0.73	0.75	5.8	S-UVT-120
	AC 200~240V/DC 250V	1.21	1.35	5.4	S-UVT-230
	AC 380~440V	1.67	-	3.8	S-UVT-410
	AC 440~480V	1.68	-	3.5	S-UVT-460
Max.opening time (msec)		50			
Tightening torque of terminal screw		7.1 lb.in.			
Transformer operating voltage (V)		0.7~1.35Vn			
- Drop (Circuit breaker trips)		~0.85Vn			
- Rise (Circuit breaker can be switched on)					

Installation - Maximum possibilities

Position	Accessory	TD125	TS250	TS400	TS800
Left	S-AX	—	1	3	3
	S-AL	1	1	—	—
	S-SHT or S-UVT	1	1	1	1
Right	S-AX	2	1	—	—
	S-AL	—	—	1	2

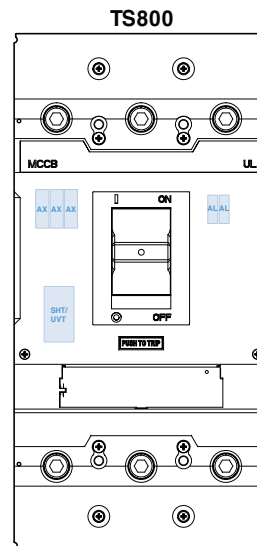
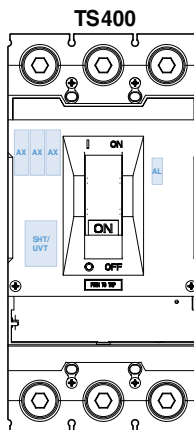
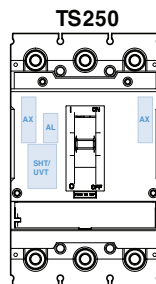
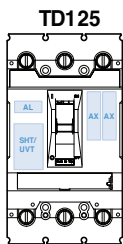

Accessories

Handle Kits

Extended Rotary Handle Kits*

Shaft length: 12", (16", 24", upon request)

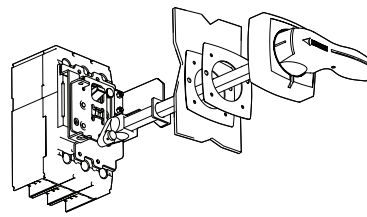

Frame Type	Cat. No. NEMA 1, 3R, 12	Cat. No. NEMA 4X
TD125	S-EHU1-12	S-EHU1-12/NEMA 4X
TS250	S-EHU2-12	S-EHU2-12/NEMA 4X
TS400	S-EHU3-12	S-EHU3-12/NEMA 4X
TS800	S-EHU4-12	S-EHU4-12/NEMA 4X

Dimensions (see page 75)

Flange Handle Kits*

Frame Type	Cable** Length	Cat. No. NEMA 1, 3R, 12
TD125	36"	S-FH1-36
TS250	48"	S-FH2-48
TS400	60"	S-FH3-60
TS800	72"	S-FH4-72

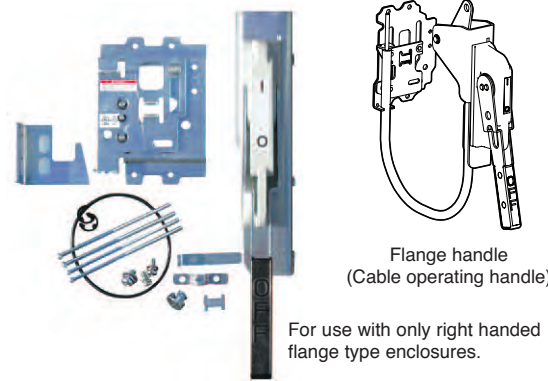

Flange handle
(Cable operating handle)

For use with only right handed flange type enclosures.

* Kits include all necessary hardware to mount to MCCB
** Longer cable available upon request.

Locking Devices

Fixed Locking Device

MCCB	Function	Cat. No. Padlockable Device
TD125	OFF or ON position	S-PHL1
TS250	OFF or ON position	S-PHL2
TS400	OFF or ON position	S-PHL3
TS800	OFF or ON position	S-PHL4

Padlocks are not supplied.

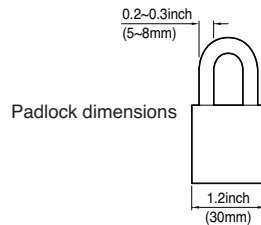

Mechanical Interlocking Device

MCCB	Cat. No. Interlocking Device
TD125	S-MIT13
TS250	S-MIT23
TS400	S-MIT33
TS800	S-MIT43

Padlocks are not supplied.

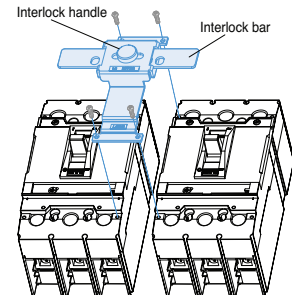

Removable Locking Device

MCCB	Function	Cat. No. Padlockable device
TD125	OFF position	S-PL1
TS250	OFF position	S-PL2
TS400	OFF position	S-PL3
TS800	OFF position	S-PL4

Padlocks are not supplied.

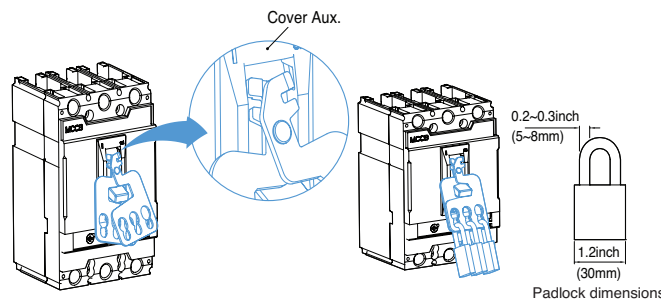

TD / TS Series Circuit Breakers Dimensions

TD125

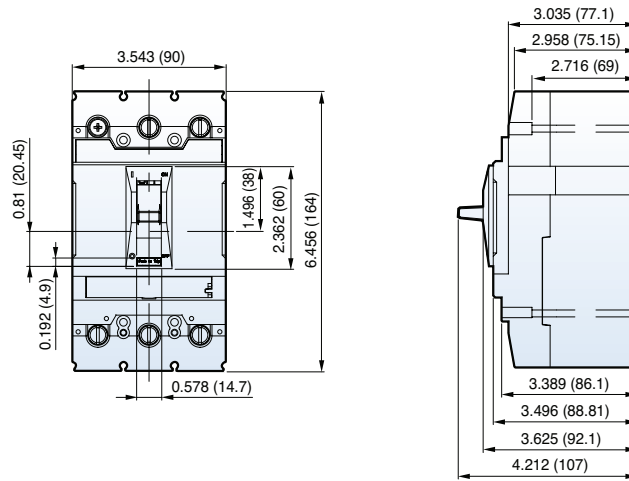

TS250

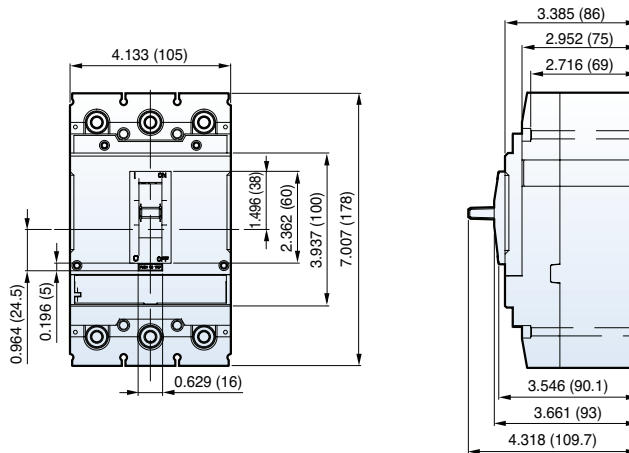

Dimensions shown in inches (mm)

TD / TS Series Circuit Breakers Dimensions

TS400

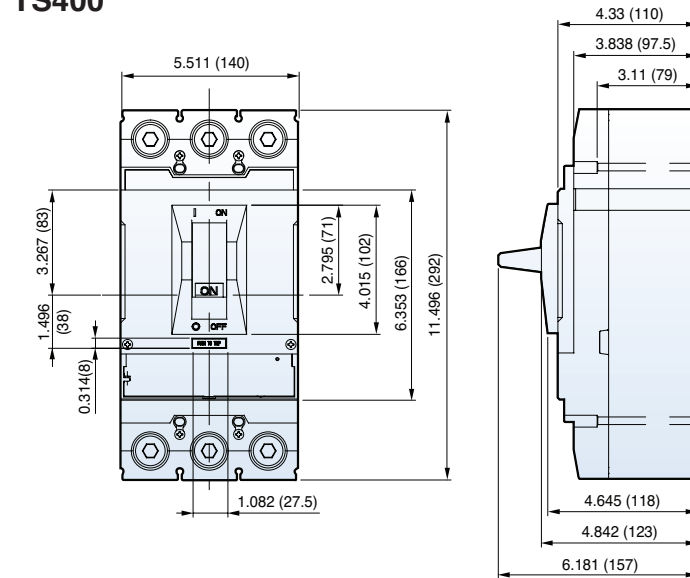

TS800

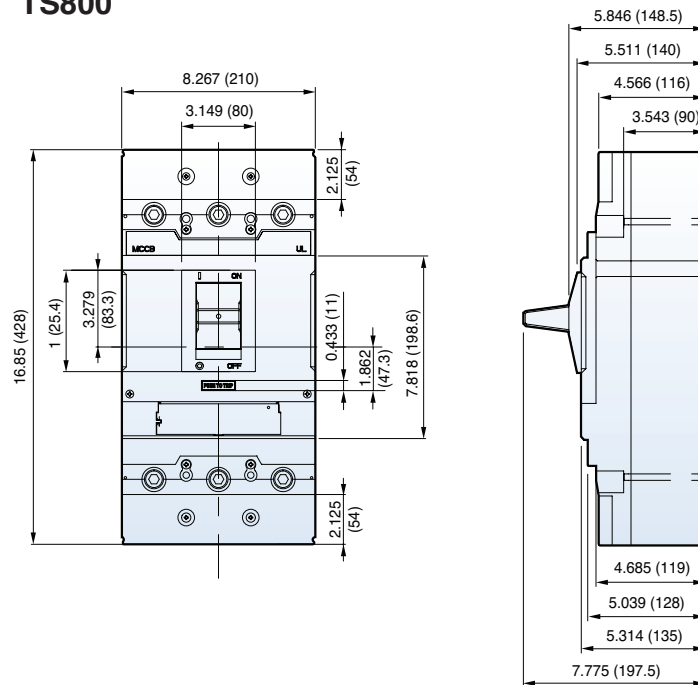

Dimensions shown in inches (mm)

Overall Dimensions - Extended Rotary Handles

TD125

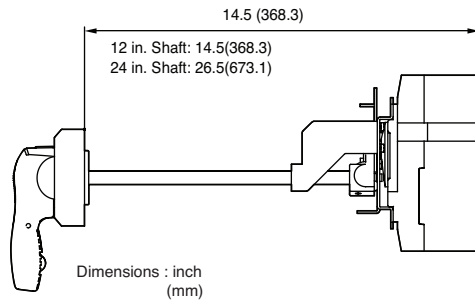

Panel drilling

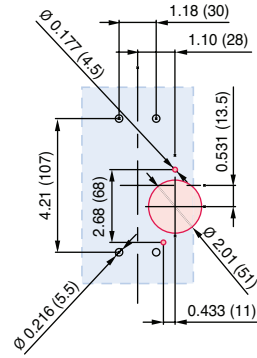

TS250

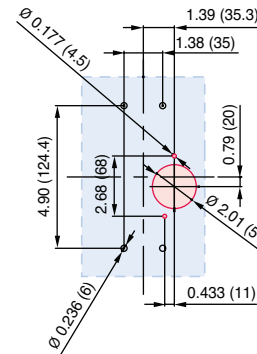
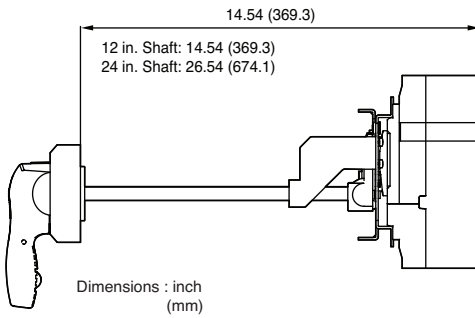

TS400

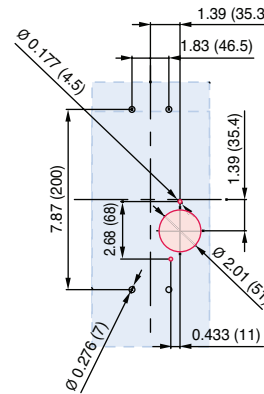
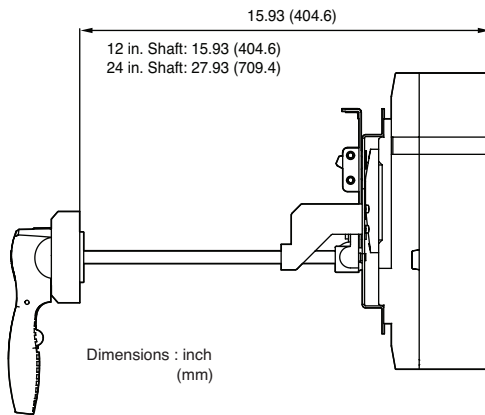

TS800

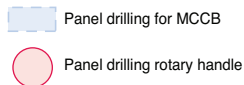
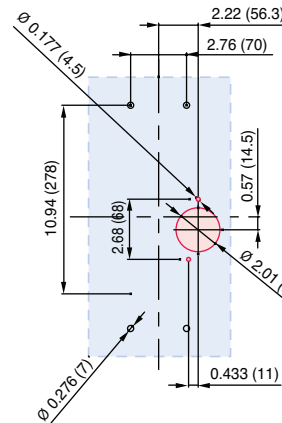
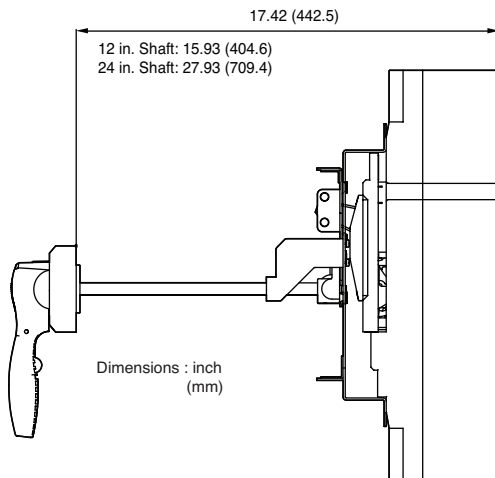

TD / TS Series Circuit Breakers Trip Curves

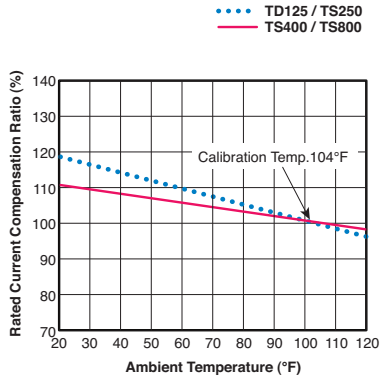

TD125 - FTU/FMU; 15~125A

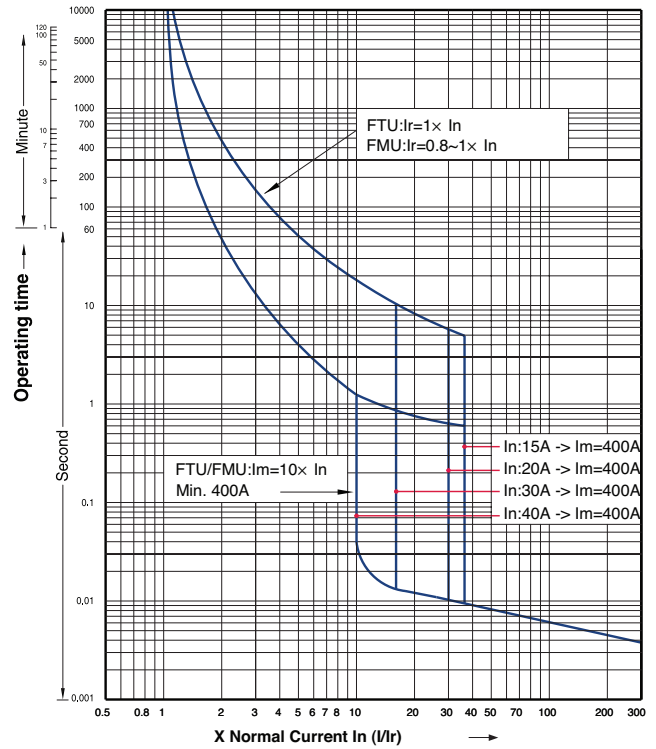

TS250 - FTU/FMU; 150~250A

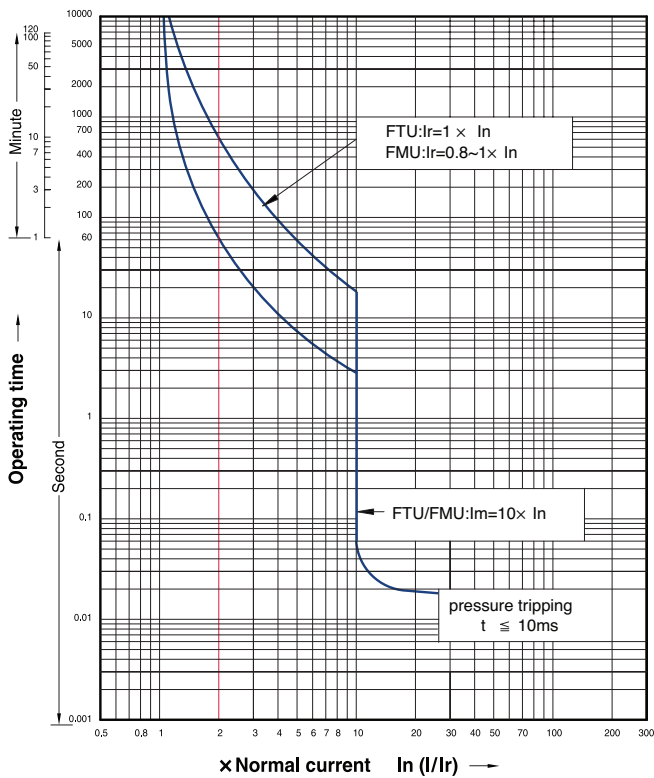

TS250 - ATU; 160~250A

