



S10040140P1

CATV Push Pull Hybrid 1000MHz 14dB

Product Description

The S10040140P1 is a Hybrid Push Pull amplifier module. The part employs GaAs/GaN die and is operated from 40 MHz to 1000 MHz. It provides excellent linearity and superior return loss performance with low noise and optimal reliability.



Package: SOT-115J

Functional Block Diagram

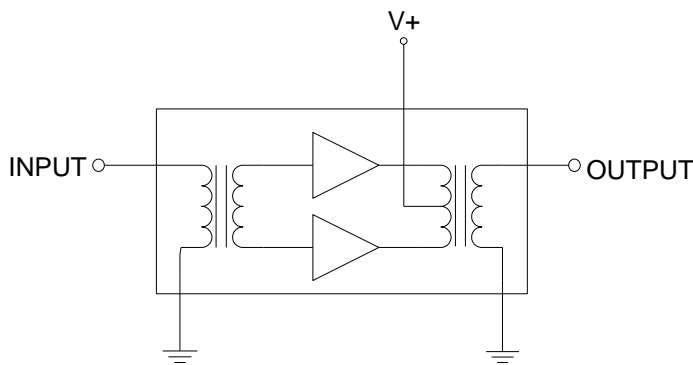

Product Features

- Excellent Linearity
- Superior Return Loss Performance
- Extremely Low Distortion
- Optimal Reliability
- Extremely Low Noise
- Unconditionally Stable Under all Terminations
- 14.0 dB Min Gain at 1000 MHz
- 260 mA Max. at 24 VDC

Applications

- 40 – 1000 MHz CATV Amplifier Systems

Ordering Information

Part No.	Description
S10040140P1	Box with 50 pcs

S10040140P1 Absolute Maximum

Parameter	Value / Range
RF Input Voltage (single tone)	65 dBmV
DC Supply over-voltage (5 minutes)	+30 V
Storage Temperature	-40 to 100 °C
Operating Mounting Base Temperature	-30 to 100 °C

Operation of this device outside the parameter ranges given above may cause permanent damage.

Electrical Specifications

Parameter	Test Conditions: $V_+ = 24V$, $T_{MB} = 30^\circ C$, $Z_S = Z_L = 75\Omega$	Min	Typ	Max	Unit
Operational Frequency Range	–	40	–	1000	MHz
Gain	$f_o = 50$ MHz		14.0		dB
Gain	$f_o = 1000$ MHz	14.0		15.5	
Gain Slope	40 to 1000 MHz ^[1]	0.5		1.5	
Gain Flatness	40 to 1000 MHz (Peak to Valley)			0.8	
Input Return Loss	$f_o = 40$ to 160 MHz	20.0		–	dB
	$f_o = 160$ to 1000 MHz	18.0		–	
Output Return Loss	$f_o = 40$ to 160 MHz	20.0		–	dB
	$f_o = 160$ to 870 MHz	18.0		–	
	$f_o = 870$ to 1000 MHz	15.0			
Noise Figure	$f_o = 50$ to 1000 MHz	–	4.5	5.5	dB
IDC			250	260	mA
CTB			-64	-60	dBc
XMOD	112 analog channels, NTSC frequency raster: 55.25 MHz to 745.25 MHz, +46dBmV flat output level. ^[2]		-55	-51	dBc
CSO			-64	-60	dBc

1. The slope is defined as the difference between the gain at the start frequency and the gain at the stop frequency.
2. Composite Triple Beat (CTB) - The CTB parameter is defined by ANSI/SCTE 6.
Composite Second Order (CSO) - The CSO parameter (both sum and difference products) is defined by ANSI/SCTE 6.
Cross Modulation (XMOD) - Cross modulation (XMOD) is defined by ANSI/SCTE 58, measured at baseband (selective voltmeter method), referenced to 100% modulation of the carrier being tested.

Package Drawing (Dimensions in millimeters)

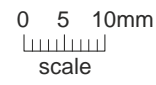
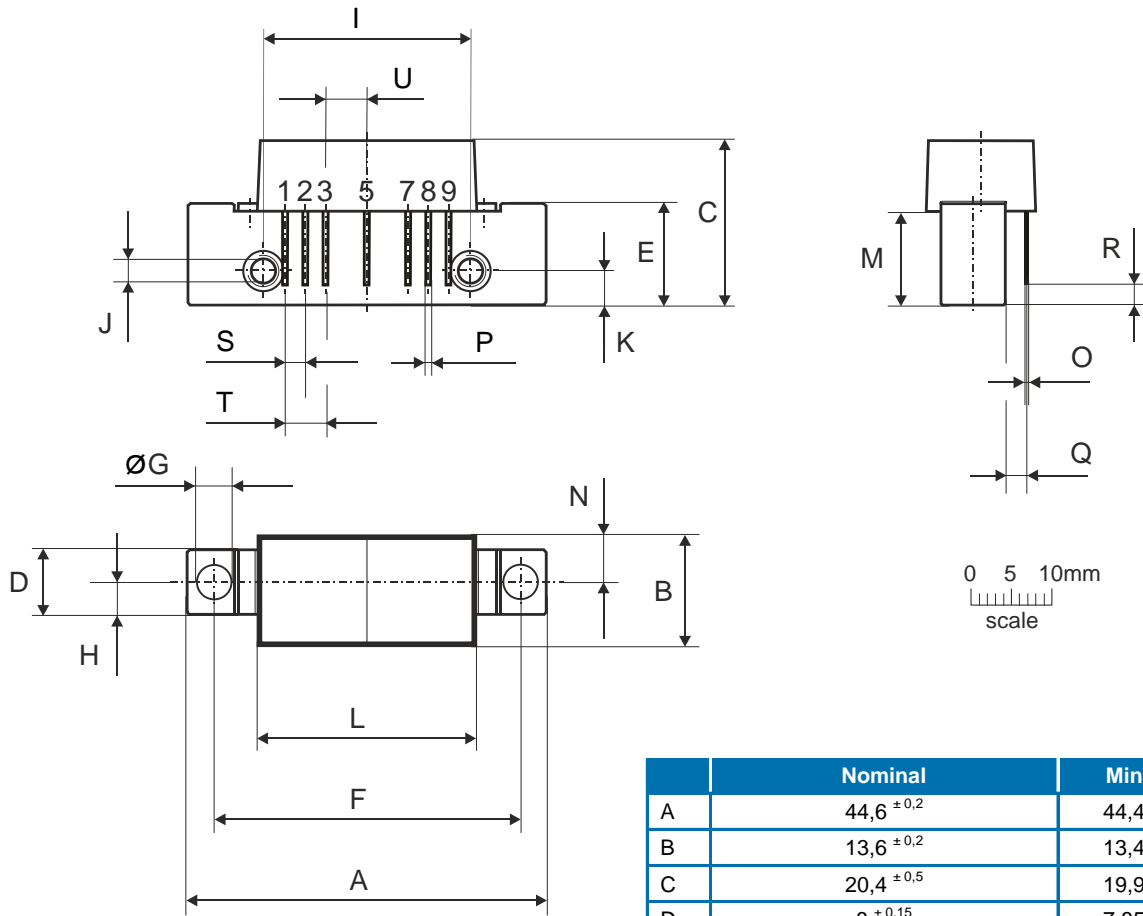

Notes:

European Projection

Pinning:

Pin	Name
1	Input
2-3	GND
4	
5	V+
6	
7-8	GND
9	Output

	Nominal	Min	Max
A	44,6 ±0,2	44,4	44,8
B	13,6 ±0,2	13,4	13,8
C	20,4 ±0,5	19,9	20,9
D	8 ±0,15	7,85	8,15
E	12,6 ±0,15	12,45	12,75
F	38,1 ±0,2	37,9	38,3
G	4 +0,2/-0,05	3,95	4,2
H	4 ±0,2	3,8	4,2
I	25,4 ±0,2	25,2	25,6
J	UNC 6-32	-	-
K	4,2 ±0,2	4,0	4,4
L	27,2 ±0,2	27,0	27,4
M	11,6 ±0,5	11,1	12,1
N	5,8 ±0,4	5,4	6,2
O	0,25 ±0,02	0,23	0,27
P	0,45 ±0,03	0,42	0,48
Q	2,54 ±0,3	2,24	2,84
R	2,54 ±0,5	2,04	3,04
S	2,54 ±0,25	2,29	2,79
T	5,08 ±0,25	4,83	5,33
U	5,08 ±0,25	4,83	5,33