

Gate Turn-off Thyristors

September 2007 Issue 4

A broad range of high specification GTO thyristors are available with blocking voltages from 1.7 kV to 6 kV and controllable current ratings to 4000A.

Our GTO thyristor portfolio incorporates a range of advanced technologies such as floating silicon, buffer layer, fine geometry, transparent emitter and advanced lifetime control techniques.

We offer both symmetrical blocking devices for applications with a reverse blocking requirement e.g. current sourced inverters and anode shorted devices for applications where anti-parallel diodes are used e.g. voltage sourced inverters.

Our experienced and dedicated technical support group is on hand with practical advice on design issues and ancillary component selection.



New Developments:

- 43mm Si Ø based on established long finger cathode design
- 4.5kV anode shorted devices planned for 2007
- 2.5kV Symmetrical devices in development for end 2007

Features and Benefits

Advanced Technologies include buffer layer, fine pattern geometry and transparent emitter .

Controllable current ratings up to 4000A.

Pressure contact construction.

Available in 6 package sizes to industry standards.

All our devices are designed, manufactured and tested to the highest standards in world class facilities and using the latest process technologies.

GTO Thyristors are still the component of choice for high power converters and Westcode remain totally committed to this technology for the foreseeable future.

Applications

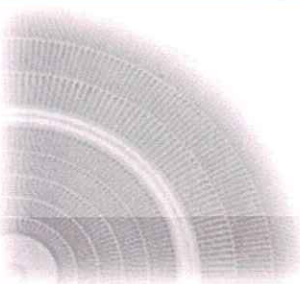

Our obsession with quality has helped us become a leading supplier of GTO thyristors into demanding markets such as traction propulsion and Auxiliaries for trams, trolley buses and light rail, marine propulsion, medium voltage drives and utilities, as well as a wide range of industrial applications such as AC industrial drives FACTs and Active VAr controllers.



PRODUCT BRIEF - Gate Turn-Off Thyristors

Summary Tables

Type	V_{DRM} (V) $V_{GK} = -2V$	V_{RRM} (V)	I_{TGM} @ C_s		V_T (V) $I_T = I_{TGM}$	t_{gt} μs	t_{gq} μs	Outline Ref	
			(A)	(μF)					
S0500KC200	2000	2000	500	1	2.5	3.5	10	A	
S0500KC20Y	200	100	500	1	2.5	3.5	10	A	
S0500KC25D	2500	2000	500	1	2.5	3.5	10	A	
S0500KC25Y	2500	100	500	1	2.5	3.5	10	A	
S0700KC140	1400	1400	700	1.5	2.2	3	10	A	
S0700KC14Y	1400	100	700	1.5	2.2	3	10	A	
S0700KC17D	1700	1400	700	1.5	2.2	3	10	A	
S0700KC17Y	1700	100	700	1.5	2.2	3	10	A	
SX185QC200*	2000	2000	In Development						B
SX185QC20Y*	2000	100	In Development						B
SX185QC25D*	2500	2000	In Development						B
SX185QC25Y*	2500	100	In Development						B
S1000NC300	3000	3000	1000	2	3.5	5	19	C	
S1000NC30Y	3000	100	1000	2	3.5	5	19	C	
S1000NC36D	3600	3000	1000	2	3.5	5	19	C	
S1000NC36Y	3600	100	1000	2	3.5	5	19	C	
S1200NC200	2000	2000	1200	3	2.7	2	12	C	
S1200NC20Y	2000	100	1200	3	2.7	2	12	C	
S1200NC25D	2500	2000	1200	3	2.7	2	12	C	
S1200NC25Y	2500	100	1200	3	2.7	2	12	C	

* Development Part Number

Fast Switching Symmetrical Blocking

Type	V_{DRM} (V) $V_{GK} = -2V$	V_{RRM} (V)	I_{TGM} @ C_s		V_T (V) $I_T = I_{TGM}$	t_{gt} μs	t_{gq} μs	Outline Ref
			(A)	(μF)				
H0500KC200	2000	2000	500	1	3.2	2	5	A
H0500KC20Y	2000	100	500	1	3.2	2	5	A
H0500KC25D	2500	2000	500	1	3.2	2	5	A
H0500KC25Y	2500	100	500	1	3.2	2	5	A
H0700KC140	1400	1400	700	1.5	2.75	3	5	A
H0700KC14Y	1400	100	700	1.5	2.75	3	5	A
H0700KC17D	1700	1400	700	1.5	2.75	3	5	A
H0700KC17Y	1700	100	700	1.5	2.75	3	5	A
H1200NC200	2000	2000	1200	3	3.3	3	5	C
H1200NC20Y	2000	100	1200	3	3.3	3	5	C
H1200NC25D	2500	2000	1200	3	3.3	3	5	C
H1200NC25Y	2500	100	1200	3	3.3	3	5	C

Anode Shorted

Type	V_{DRM} (V) $V_{GK} = -2V$	V_{RRM} (V)	I_{TGM} @ C_s		V_T (V) $I_T = I_{TGM}$	t_{gt} μs	t_{gq} μs	Outline Ref
			(A)	(μF)				
GX152QC450*	4500	18	1000	In Development				A
G1000NC450	4500	18	1000	2	4.0	2	16	C
G1500NL250	2500	18	1500	3	2.5	3	15	C
G2000VC250	2500	18	2000	4	2.8	5	24	D
G2000VC450	4500	18	2000	4	3.5	8	25	D
G3000TC250	2500	18	3000	5	2.5	7.5	28	E
G3000TC450	4500	18	3000	6	4.0	9	28	E
G3000TC600	6000	18	3000	3	3.5	7.5	28	E
G4000EC450	4500	18	4000	6	4.4	7.5	28	F

* Development Part Number

Outline Dimensions

Outline Ref	A mm	B mm	C mm
A	30	50	16
B	38	60	26
C	47	75	28
D	63	93	26
E	75	108	26
F	85	120	26

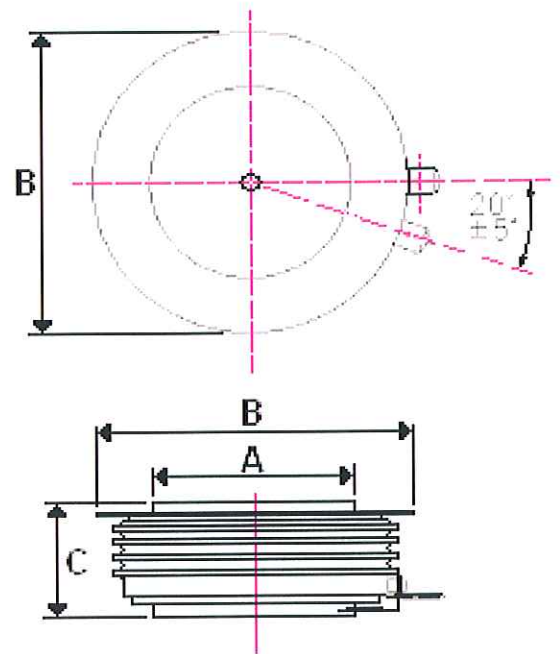

To support our range of GTO thyristors, we offer a range of complementary products including anti-parallel diodes, snubber diodes, snubber capacitors, mounting clamps and thermal management solutions.

WESTCODE

An IXYS Company

Contact us: Westcode Semiconductors Ltd
Langley Park Way
Chippenham SN15 1GE
United Kingdom
Tel: +44 (0)1249 444524
Fax: +44 (0)1249 659448
Email: wsl.sales@westcode.com

IXYS

IXYS Semiconductors GmbH
Edisonstr. 15
D-68623 Lampertheim
Germany
Tel: +49 (0) 6206 503-0
Fax: +49 (0) 6206 503627
Email: marcom@ixys.de



Certificate No. FM 26085

Westcode Semiconductors Limited's BS EN ISO 9001 Quality System is registered by BSI.

We are supported by a global network of local offices, representatives and distributors. Please visit our websites for further information.

www.ixys.com

www.westcode.com