

## Quick Start Guide S12ZVM32EVB

Highly Integrated Microcontroller  
Enhanced S12Z Core at 50 MHz Bus Speed  
Up to 32 KB Flash and 4 KB RAM

TOWER® SYSTEM DEVELOPMENT PLATFORM



### GET TO KNOW THE S12ZVM32EVB BOARD

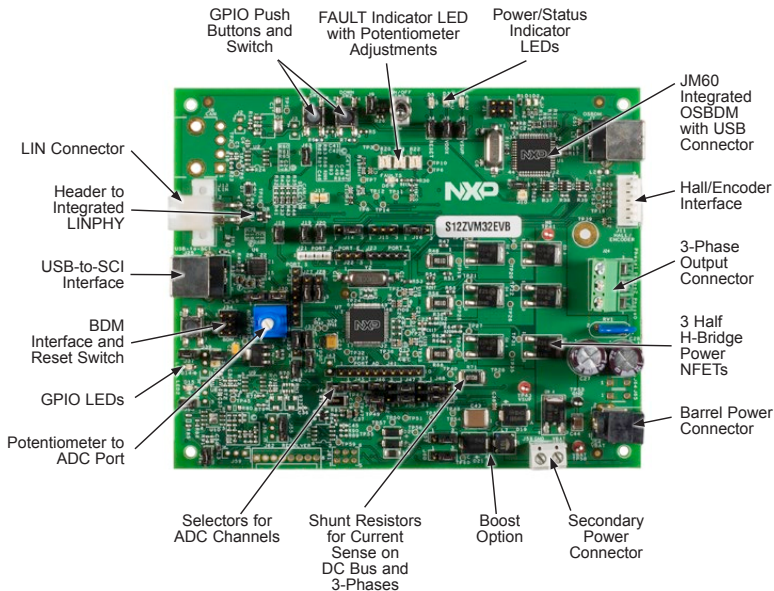

Front Side of the S12ZVM32EVB Board

## INTRODUCTION AND DEFAULT SETTINGS

The S12ZVM32EVB features the S12ZVM128 microcontroller, an automotive 16-bit MCU for three-phase BLDC motor control applications. The S12ZVML31 integrates an S12Z CPU, a LIN physical interface, a 5 V regulator system to supply the microcontroller, and a gate driver unit (GDU) to drive up to six external power N-channel MOSFETs.

The board includes an onboard OSBDM, a USB-to-SCI interface, a resolver interface, a hall sensor interface, an external 4 MHz oscillator, current sense resistors, multiple op-amps for signal conditioning of voltage and current measurements, and the option for an external CAN transceiver.

Default jumper positions of the S12ZVM32EVB board are shown in the figure at right.

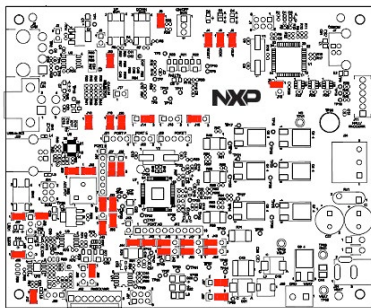

### SOFTWARE TOOLS INSTALLATION

#### 1 Install CodeWarrior® Development Studio

NXP®'s CodeWarrior development studio for MCUs integrates the development tools for several architectures, including the S12Z architecture, into a single product based on the Eclipse open development platform. Eclipse offers an excellent framework for building software development environments and is a standard framework used by many embedded software vendors.

The latest version of CodeWarrior for MCUs (Eclipse IDE) can be downloaded from [www.nxp.com/CodeWarrior](http://www.nxp.com/CodeWarrior).

#### 2 Download Additional Software

Visit [www.nxp.com/S12ZVM](http://www.nxp.com/S12ZVM) and download our example codes, such as PMSM motor controller, BLDC motor controller, LIN Driver, MSCAN, HVI, etc.

## JUMPER DEFAULT CONFIGURATION

JUMPER	SETTING	DESCRIPTION
J4	1–2	RESET LED indicator enabled
J5	1–2	$V_{DD}$ LED indicator enabled
J6	1–2	$V_{SUP}$ LED indicator enabled
J9	1–2	PT1 “ON/OFF” switch enabled
J10	Open	OSBDM boot loader disabled
J12	1–2	Resolver (+5 VDC) supplied from $V_{DDX}$
J14	2–3	PP0 connected to supply EVDD to hall sensor interface
J16	1–2	PT2 connected to Hall/encoder Phase B
J18	1–2	$V_{DDX}$ supplies 5 V to the USB-to-SCI isolator
J19	1–2	PP1 “UP” push button enabled
J20	1–2	PP2 “DOWN” push button enabled
J27	2–3	SCI1 RXD connected to USB-to-SCI
J28	2–3	SCI1 TXD connected to USB-to-SCI
J29	1–2	$V_{DDX}$ supplies 5 V to BDM header
J30	1–2	$V_{DDX}$ supplies 5 V to ADC potentiometer
J33	1–2	MCU $V_{SUP}$ connected
J35	1–2	PAD0 (AMP0) connected to external gain setting resistors
J36	1–2	$V_{REF}$ generation supplied from VSUP enable
J37	1–2	PS4 “User LED 1” enabled
J40	1–2	$V_{SUP}$ supply to $V_{DDX}$ ballast

### JUMPER DEFAULT CONFIGURATION (CONT.)

JUMPER	SETTING	DESCRIPTION
J44	1–2	PAD1 (AMPM0) connected to external gain setting resistors
J45	1–2	PAD2 (AMPPO) connected to external gain setting resistors
J46	1–2	PAD3 (AN0_3) connected to ADC_IA (Phase A current sense from external op-amp)
J47	1–2	PAD4 (AN0_4) connected to ADC_IB (Phase B current sense from external op-amp)
J48	1–2	PAD5 (AMP1) connected to external gain setting resistors
J50	1–2	PAD6 (AMPM1) connected to external gain setting resistors
J51/J42	1–2	PAD7 (AMP1) connected to external gain setting resistors
J52	2–3	PAD8 (AN1_3) connected to ADC_IC (Phase C current sense from external op-amp)
J53	1–2	PS5 “User LED 2” enabled
J55	1–2	$V_{REF}$ supplied from $V_{DDX}$
J57	2–3	Current sense op-amp inverting input connected to Ground (DC Bus current sense)
J60	2–3	Current sense op-amp non-inverting input connected to DC Bus (DC Bus current sense)
J63	1–2	$V_{DDX}$ supply 5 V to FAULT comparator circuits

## JUMPER LIST AND DESCRIPTION

JUMPER	DESCRIPTION
J2	CAN transceiver 5 V supply option
	Closing this jumper, the $V_{DDC}$ ballast transistor is supplied from VSUP
J3	$V_{DDC}$ supplied from USB option
	Closing this jumper, the $V_{DDC}$ node is supplied from the USB-to-SCI interface
J4	RESET LED indicator option
	Closing this jumper, the LED indicator for RESET is connected to RESET
J5	$V_{DDX}$ LED indicator option
	Closing this jumper, the LED indicator for $V_{DDX}$ is connected to $V_{DDX}$
J6	$V_{SUP}$ LED indicator option
	Closing this jumper, the LED indicator for $V_{SUP}$ is connected to $V_{SUP}$
J9	ON/OFF switch option
	Closing this jumper connects the "ON/OFF" GPIO switch to port PT1
J10	OSBDM boot-loader option
	Closing this jumper, the OSBDM enters in boot-loader mode
J12	Resolver circuit 5 V supply option
	Closing this jumper connects $V_{DDX}$ to supply 5 V at the Resolver circuit
J14	EVDD or FAULT selector
	Pins 1-2 closed: FAULT input is connected to port PPO
	Pins 2-3 closed: Port PPO is connected to EVDD at Hall sensor interface

### JUMPER LIST AND DESCRIPTION (CONT.)

JUMPER	DESCRIPTION
J15	Resolver or Hall/encoder Phase A selector
	Pins 1-2 closed: Phase A from Resolver is connected to port PT1
	Pins 2-3 closed: Phase A from Hall/encoder interface is connected to port PT1
J16	Resolver or Hall/encoder Phase B selector
	Pins 1-2 closed: Phase B from Hall/encoder interface is connected to port PT2
	Pins 2-3 closed: Phase B from Resolver is connected to port PT2
J18	USB-to-SCI interface supply option
	Closing this jumper, $V_{DDX}$ supplies 5 V to the USB-to-SCI isolator
J19	"UP" push-button option
	Closing this jumper, the "UP" GPIO push button is connected to port PP1
J20	"DOWN" push-button option
	Closing this jumper, the "DOWN" GPIO push button is connected to port PP2
J27	SCI RXD selector
	Pins 1-2 closed: RXD from OSBDM is connected to port PS2
	Pins 2-3 closed: RXD from USB-to-SCI is connected to port PS2
J28	SCI TXD selector
	Pins 1-2 closed: TXD from OSBDM is connected to port PS3
	Pins 2-3 closed: TXD from USB-to-SCI is connected to port PS3
J29	BDM interface supply option
	Closing this jumper, the 5 V pin on the BDM interface is connected to $V_{DDX}$



## JUMPER LIST AND DESCRIPTION (CONT.)

JUMPER	DESCRIPTION
J30	ADC potentiometer pull-up option
	Closing this jumper, $V_{DDX}$ supplies 5 V to POT 1 (ADC potentiometer)
J33	Microcontroller supply option
	Closing this jumper connects the $V_{SUP}$ pin of the MCU to the supply voltage $V_{SUP}$
J35	ADC mapping – PAD0
	Pins 1-2 closed – Connects PAD0 to AMP0 external gain-setting resistors
	Pins 2-3 closed – Connects PAD0 to POS_SIN resolver output
J36	$V_{REF}$ generation supply option
	Closing this jumper connects $V_{SUP}$ to supply a regulated voltage at $V_{REF2}$
J37	USER LED1 option
	Closing this jumper, the GPIO LED1 is connected to port PS4
J39	Resolver Phase B selector
	Pins 1-2 closed – SINCOS I/O connector Phase B connected to Resolver Phase B input
	Pins 2-3 closed – POS_COS connected to Resolver Phase B input
J40	$V_{DX}$ ballast supply option
	Closing this jumper, the $V_{DDX}$ ballast is connected to $V_{SUP}$
J43	Resolver circuit 12 V supply option
	Closing this jumper, the 12 V supply to the resolver circuit op-amps is supplied from $V_{SUP}$

### JUMPER LIST AND DESCRIPTION (CONT.)

JUMPER	DESCRIPTION
J44	ADC mapping—PAD1
	Closing this jumper, PAD1 is connected to the AMPM0 external gain-setting resistors
J45	ADC mapping—PAD2
	Closing this jumper, PAD2 is connected to the AMPP0 external gain-setting resistors
J46	ADC mapping—PAD3
	Pins 1-2 closed—connects PAD3 to ADC_IA (Phase A current sense from external op-amp)
	Pins 2-3 closed—connects PAD3 to POS_SIN resolver output
J47	ADC mapping—PAD4
	Pins 1-2 closed—connects PAD4 to ADC_IB (Phase B current sense from external op-amp)
	Pins 2-3 closed—connects PAD4 to ADC potentiometer POT1
J48	ADC mapping—PAD5
	Pins 1-2 closed—connects PAD5 to AMP1 external gain setting resistors
	Pins 2-3 closed—connects PAD5 to ADC_IB (Phase B current sense from external op-amp)

## JUMPER LIST AND DESCRIPTION (CONT.)

JUMPER	DESCRIPTION
J49	Resolver phase A selector
	Pins 1-2 closed—resolver Phase A connected to SINCOS I/O connector Phase A input
	Pins 2-3 closed—resolver Phase A connected to Resolver POS_SIN Schmitt-Trigger
J50	ADC mapping—PAD6
	Pins 1-2 closed—connects PAD6 to AMPM1 external gain-setting resistors
	Pins 2-3 closed—connects PAD6 to POS_COS resolver output
J51/J42	ADC mapping—PAD7
	J51 pins 1-2 closed—connects PAD7 to AMPP1 external gain-setting resistors
	J51 pins 2-3 closed—connects PAD7 to POS_SIN resolver output
	J51 pin 2 to J42 pin 1 closed—connects PAD7 to ADC potentiometer POT1
J52	ADC mapping—PAD8
	Pins 1-2 closed—connects PAD8 to ADC_IC (Phase C current sense from external op-amp)
	Pins 2-3 closed—connects PAD8 to POS_COS resolver output
J53	USER LED2 option
	Closing this jumper, the GPIO LED2 is connected to port PS5
J55	$V_{REF}$ selector
	Pins 1-2 closed— $V_{REF}$ supplied from $V_{DDX}$
	Pins 2-3 closed— $V_{REF}$ supplied from the $V_{REF2}$ regulator

### JUMPER LIST AND DESCRIPTION (CONT.)

JUMPER	DESCRIPTION
J56	Resolver COS reference
	Pins 1-2 closed: Input to POS_COS circuit is from OFFSET1
	Pins 2-3 closed: Input to POS_COS circuit is from RES_COS_REF
J57	Internal AMP0 input selector (inverting)
	Pins 1-2 closed—connects DC Bus to the internal AMP0 inverting input (Phase A current sense)
	Pins 2-3 closed—connects Ground to the internal AMP0 inverting input (DC Bus current sense)
J59	Resolver SIN reference
	Pins 1-2 closed: Input to POS_SIN circuit is from RES_SIN_REF
	Pins 2-3 closed: Input to POS_SIN circuit is from OFFSET1
J60	Internal AMP0 input selector (non-inverting)
	Pins 1-2 closed—connects Phase A to the internal AMP0 non-inverting input (Phase A Current sense)
	Pins 2-3 closed—connects DC Bus as non-inverting input for internal AMP0 (DC Bus current sense)
J63	FAULT comparators 5 V supply option
	Closing this jumper connects $V_{DDX}$ to supply 5 V at the FAULT circuit

## HEADERS AND CONNECTORS LIST

HEADER/CONNECTOR	DESCRIPTION
J1	External BDM connector for OSBDM (1. BKGD, 2. Ground, 3. PDO, 4. RESET, 5. PDOCLK, 6. $V_{DD}$ )
J7	OSBDM USB connector
J8	CAN connector (1. MSCAN_H, 2. MSCAN_L, 3. Open, 4. Open)
J11	Hall sensor/encoder interface (1. EVDD, 2. GND, 3. Ph-A, 4. Ph-B, 5. Ph-C)
J13	LIN connector (1. GND, 2. GND, 3. +12 V [HD], 4. LIN)
J17	LINPHY interface (1. LPRXD, 2. LPTXD)
J21	Port P Header (1. PP0, 2. PP1, 3. PP2, 4. GND)
J22	Port E Header (1. PE0, 2. PE1, 3. GND)
J23	Port T Header (1. PT3, 2. PT2, 3. PT1, 4. PT0, 5. GND)
J24	Three-Phase Motor power output connector
J25	USB-to-SCI USB connector

### HEADERS AND CONNECTORS LIST (CONT.)

HEADER/CONNECTOR	DESCRIPTION
J31	Port S Header (1. PS0, 2. PS1, 3. PS2, 4. PS3, 5. PS4, 6. PS5, 7. GND)
J34	External BDM connector for S12ZVM MCU
J38	Header for extended debug interface (1. PDOCLK, 2. PDO)
J41	Port AD Header (1. AN0, 2. AN1, 3. AN2, 4. AN3, 5. AN4, 6. AN5, 7. AN6, 8. AN7, 9. AN8, 10. GND)
J54	DC connector for wall power supply
J58	Alternative power supply connector
J61	SINCOS I/O Connector (1. Phase A, 2. SIN, 3. Phase B, 4. COS, 5. GND, 6. +5VA)
J62	Resolver I/O Connector (1. GEN_P, 2. GEN_M, 3. SIN, 4. SIN_REF, 5. COS, 6. COS_REF, 7. GND, 8. +5VA)
J64	Alternative connector (blade) for power supply (+12 V) input
J65	Alternative connector (blade) for ground

## POTENTIOMETERS

POTENTIOMETER	DESCRIPTION
R59	POT1, routable to ADC input AN8
R78	Resolver generator gain setting potentiometer
R77	Resolver interface offset adjustment
R20	Phase current threshold setting for FAULT5 generation
R123	DC Bus voltage threshold setting for FAULT5 generation

## LEDS

LEDS	DESCRIPTION
D1	OSBDM Status LED (Green)
D2	OSBDM Power LED (Yellow)
D3	$V_{DD}$ LED (Green)
D4	$V_{SUP}$ LED (Yellow)
D5	RESET LED (Red)
D14	USER LED 1 (Blue)
D15	USER LED 2 (Blue)
D6	FAULT5 LED (Red)