

# S186ELD(Q) Laser Diode Emitter



## Datasheet

Class 1 Laser for Use With Banner Modulated Photoelectric Receivers



- Self-contained Class 1 modulated visible laser diode emitters permit higher gain and extended range in opposed mode sensing systems
- Narrow effective beam for small-object detection or for precise position control
- 10 V dc to 30 V dc operation; third wire extinguishes laser light when connected to +V dc
- Compatible with all EZ-BEAM® receivers; may also be used with a variety of other Banner modulated photoelectric receivers
- 18 millimeter threaded barrel design



**WARNING:**

- **Do not use this device for personnel protection**
- Using this device for personnel protection could result in serious injury or death.
- This device does not include the self-checking redundant circuitry necessary to allow its use in personnel safety applications. A device failure or malfunction can cause either an energized (on) or de-energized (off) output condition.

## Models

Model	Range	Cable <sup>1</sup>	Supply Voltage	Effective Beam at Receiver at 25 °C	
				Opposed Distance	Beam Width
S186ELD	Range varies, depending on which receiver is used (see <a href="#">Excess Gain</a> on page 3)	2 m (6.5 feet) Unterminated	10 V dc to 30 V dc	1.5 m (5 ft)	4 mm (0.2 in)
S186ELDQ		4-wire Euro-style Quick-Disconnect Connector		3.0 m (10 ft)	5.5 mm (0.2 in)
				6.1 m (20 ft)	8.5 mm (0.3 in)
				15 m (50 ft)	18 mm (0.7 in)
				30 m (100 ft)	32 mm (1.3 in)

## Description of Class 1 Lasers



**CAUTION:**

- **Never stare directly into the sensor lens.**
- Laser light can damage your eyes.
- Avoid placing any mirror-like object in the beam. Never use a mirror as a retroreflective target.

### Class 1 Lasers

Class 1 lasers are lasers that are safe under reasonably foreseeable conditions of operation, including the use of optical instruments for intrabeam viewing.

Reference IEC 60825-1:2001, Section 8.2.



### Class 1 Laser Characteristics:

**Wavelength:** 650 nm

**Pulse Power:** ≤ 1 milliwatt

**Pulse Width:** 7 microseconds

**Rep Rate:** 30 microseconds

## Installation Instructions

### Mount the Device

1. If a bracket is needed, mount the device onto the bracket.
2. Mount the device (or the device and the bracket) to the machine or equipment at the desired location. Do not tighten the mounting screws at this time.

<sup>1</sup> To order the 9 m (30 ft) PVC cable model, add the suffix "W/30" to the cabled model number. For example: S186ELD W/30. Models with a quick disconnect require a mating cordset.



3. Check the device alignment.
4. Tighten the mounting screws to secure the device (or the device and the bracket) in the aligned position.

## Wiring Diagrams

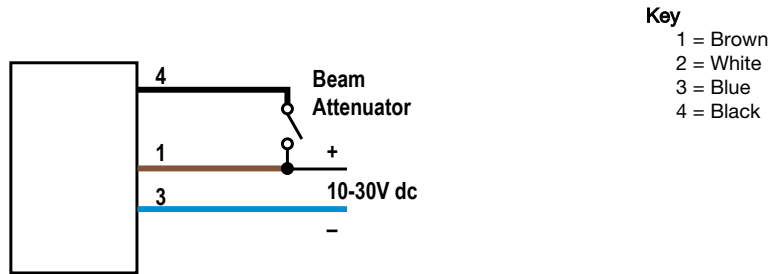

**Key**  
 1 = Brown  
 2 = White  
 3 = Blue  
 4 = Black



**Note:** Quick disconnect wiring diagrams are functionally identical.

## Alignment

The beam size listed in [Figure 1](#) on page 2 is also the effective beam size at the receiver. The effective beam is equal to the minimum opaque object profile required to block the light beam. The beam size at the emitter is 2.5 mm (0.1 in) diameter.

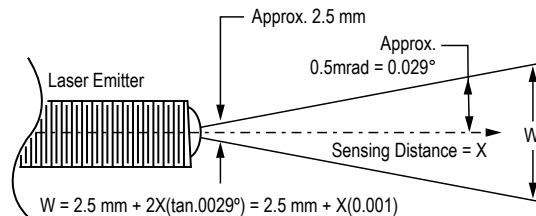

Opposed Distance (X)	Beam Width (W)
1.5 m (5 ft)	4 mm (0.2 in)
3.0 m (10 ft)	5.5 mm (0.2 in)
6.1 m (20 ft)	8.5 mm (0.3 in)
15 m (50 ft)	18 mm (0.7 in)
30 m (100 ft)	32 mm (1.3 in)

Figure 1. Laser emitter beam divergence at 25 °C (beam size vs. distance)

The effect of angular misalignment is dramatic (see [Figure 2](#) on page 2). Laser emitters require the beam center to directly strike the receiver lens. [Figure 2](#) on page 2 shows how far the laser beam will miss the center of the receiver lens for each degree of angular misalignment. Note that even at only a 1.5 m (5 ft) range, one degree of misalignment causes the laser beam to miss the lens of most receivers.



**Tip:** The visible red beam of the laser emitter is easily seen in subdued lighting. At opposed distances of up to 3 m (10 ft), attach a sheet of white paper directly in front of the receiver lens. Mark the location of the lens center on the paper; use the mark as an aiming target. Sight along the beam from directly behind the laser emitter. Adjust the emitter mounting until the red image (the dot of red light) is centered exactly on the mark. Remove the paper and check the response of the receiver.

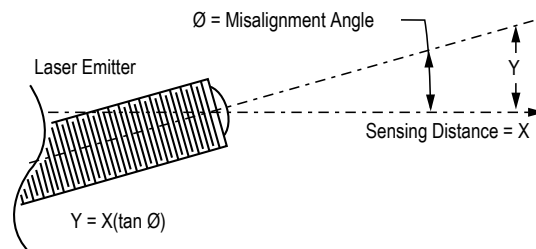

Opposed Distance (X)	Beam Displacement (Y) of 1° of Misalignment
1.5 m (5 ft)	4 mm (0.2 in)
3.0 m (10 ft)	50 mm (2 in)
6.1 m (20 ft)	100 mm (4 in)
15 m (50 ft)	250 mm (10 in)
30 m (100 ft)	500 mm (20 in)

Figure 2. Beam Displacement per degree of misalignment

For longer distances (up to 7.6 m [25 ft]), replace the white paper with a 100 mm (4 in) × 100 mm (4 in) square of high-grade retroreflective tape (Banner model BRT-THG-4X4-5 or equivalent; see [Figure 3](#) on page 3). For greater distances, use a larger sheet of retroreflective material.



**Note:** Never use a mirror as an alignment target.

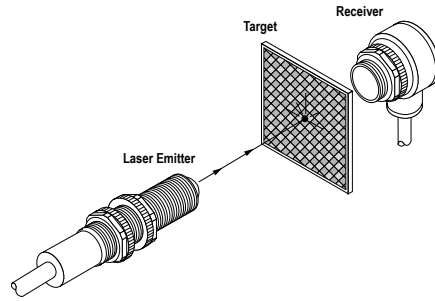

Figure 3. At long distances, use retroreflective tape to locate the beam at the receiver location

## Specifications

### Supply Voltage and Current

10 V dc to 30 V dv (10% maximum ripple) at less than 35 mA

### Supply Protection Circuitry

Protected against reverse polarity

### Sensing Beam

Visible red Class 1 laser, 650 nm (temperature coefficient 0.2 nm/°C)

**Pulse Width:** 7 μs

**Rep Rate:** 30 μs

**Peak Output Power:** less than 1 milliwatt

### Beam Diameter at Aperture

2.5 mm (0.10 in) collimated ellipse

### Beam Divergence

±0.5 milliradians typical

### Laser Control

Enable the beam by applying 0 V dc or by opening the circuit; apply +10 V dc to 30 V dc to the black wire to inhibit the beam

### Indicators

Green indicator, visible through the rear cover, indicates power is applied

### Construction

M18 x 1 threaded yellow PBT polyester barrel housing. Acrylic lens. Electronics totally encapsulated. Two mounting nuts are included.

### Environmental Rating

NEMA 6P; IEC IP67

### Connections

2 m (6.5 ft) or 9 m (30 ft) unterminated 4-wire PVC cable  
Integral 4-pin M12/Euro-style quick disconnect

### Operating Conditions

**Temperature:** -10 °C to +50 °C (+14 °F to +122 °F)  
90% at +50 °C maximum relative humidity (non-condensing)

### Laser Classification

Class 1 laser product complies with 21 CFR 1040.10, EN60825-1:2001, except for deviations pursuant to Laser Notice 50, dated 7-26-01.

### Certifications

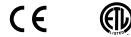

## Dimensions

All measurements are listed in millimeters [inches], unless noted otherwise.

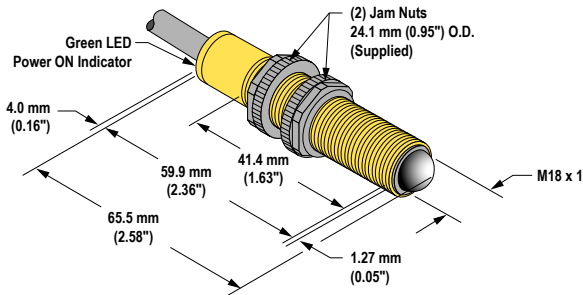

Figure 4. Cabled Model

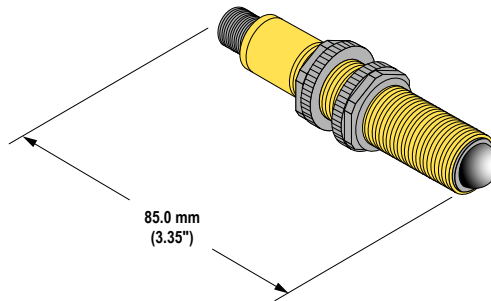

Figure 5. Quick-Disconnect Model

## Excess Gain

Excess Gain of the S186ELD emitter depends on the receiver used. Following is a comparison of the excess gain for recommended receivers at 15 m (50 ft). For information on compatibility of the S186ELD emitter with other Banner photoelectric receivers, contact Banner Engineering.

MULTI-BEAM®	MAXI-BEAM®	VALU-BEAM®	EZ-BEAM®	MINI-BEAM®	ECONO-BEAM®	Others
SBRX1 3,000	RSBR 750	SMW95R 5,000	T18SN6R 400	SM31R 300	SE61R 45	SM51RB 140
SBR1 3,000	RSBRSR 120	SMI91RQD 3,000	T30SN6R 400	SM31RL 1,700	SE61RMHS 40	Q23SN6R 25
SBRXD1 3,000			S12SN6R 400	SM31RMHS 200		Q10AN6R 20
SBRD1 3,000				SM31RLMHS 1,100		Q45BB6R 1,500