

8GB, 3.3 V, e.MMC Flash

Features

- **e.MMC 5.1 Specification Compatible**
 - Backward compatible with previous e.MMC specifications
- **Operating Voltage**
 - V_{CCQ} : 1.7V - 1.95V
 - V_{CC} : 2.7V - 3.6V
- **Density: 4 / 8 / 16 GB of Data Storage**
- **Data Bus Width:**
 - SDR Mode: 1 bit, 4 bit, 8 bit
 - DDR Mode: 4 bit, 8 bit
 - HS200 Mode: 4 bit, 8 bit
 - HS400 Mode: 8 bit
- **Clock Frequency: 52 MHz, 200 MHz**
 - SDR Mode: up to 52 MHz
 - DDR Mode: up to 52 MHz
 - HS200 Mode: up to 200 MHz
 - HS400 Mode: up to 200 MHz
- **BGA Packages**
 - 153-ball VFBGA — 11.5 mm x 13 mm x 0.8 mm
- **Operating Temperature Range**
 - Industrial (–40°C to + 85°C)
 - Industrial Extended (–40°C to + 105°C)
 - Automotive (–40°C to + 85°C)
 - Automotive Extended (–40°C to + 105°C)

Key Supported Features

- HS400, HS200
- Boot Feature/ Boot Partition
- Partitioning, RPMB, RPMB Throughput Improve
- HPI, BKOPS, BKOP Operation Control
- Sanitize, Discard, Trim, Erase
- Lock/Unlock
- High Priority Interrupt
- Secure Removal Type
- Configurable Drive Strength
- Write protect, Secure Write Protection
- Cache, Cache Barrier, Cache Flushing Report
- Reliable Write
- Hardware/ Software Reset
- Health Monitoring
- Field Firmware Update
- PON, Sleep/Awake
- Packed CMD, CMD Queuing
- Data Strobe Pin, Enhanced Data Strobe
- Production State Awareness

Performance and Power Consumption (Temperature = 25°C)

Table 1 MLC Partition Sequential Performance

Condition ^[1]	Typ. Values (MB/s)
	8GB
Write	68
Read	278

Note:

1. Bus in x8 I/O, HS400 mode. Sequential Access of 1MB chunk

Table 2 MLC Partition Random Performance

Condition ^[2]	Typ. Values (IOPS)	
	8GB	
	Burst	Sustained
Write (Cache On)	17588	16280
Write (Cache Off)	2284	2145
Read	N/A	6290

Note:

2: Bus in x8 I/O, HS400 mode. Random Access of 4KB chunk over 1GB span

Table 3 Power Consumption

eMMC				RMS		Idle		Sleep			
Density	Speed	VCC/VCCQ	Operation	ICC(mA)	ICCQ(mA)	ICC(μA)	ICCQ(μA)	ICC(μA)	ICCQ(μA)		
8GB	SDR52	3.6/1.95	Read	24	95	110	470	100	450		
			Write	32	76						
	DDR52	3.6/1.95	Read	42	123						
			Write	45	74						
	HS200	3.6/1.95	Read	80	121						
			Write	59	84						
			HS400	3.6/1.95	Read					111	144
					Write					59	82

Table of Contents

Features	1	11. Document History Page	34
Key Supported Features	1		
Performance and Power Consumption	2		
1. General Description	4		
2. SkyHigh Product Offering	4		
3. Package Configurations	5		
4. Architecture	7		
5. Key Supported e.MMC Features	7		
5.1 Boot Operation.....	7		
5.2 Partition Management.....	8		
5.3 Sleep (CMD5)	9		
5.4 High Priority Interrupt (HPI).....	9		
5.5 Background Operations	9		
5.6 Auto Background Operations.....	9		
5.7 Trim.....	9		
5.8 Sanitize	9		
5.9 Hardware Reset.....	9		
5.10 Health Monitoring.....	10		
5.11 Field Firmware Update.....	10		
6. Register Values	10		
6.1 OCR Register.....	10		
6.2 CID Register	11		
6.3 Product Table.....	11		
6.4 CSD Register.....	12		
6.5 Extended CSD Register (EXT_CSD).....	13		
7. AC Parameter	19		
7.1 Bus Timing	19		
7.2 High Speed Timing	20		
7.3 Backward Compatible Timing	21		
7.4 DDR Interface Timing	21		
7.5 Timing Specifications for HS200 Mode.....	21		
HS200 Clock Timing	21		
HS200 Input Timing	22		
HS200 Output Timing	23		
7.6 Bus Timing Specification in HS400 Mode.....	24		
HS400 Device Input Timing	23		
HS400 Device Output Timing	24		
HS400 Device Command Output Timing	27		
7.7 Signal Levels.....	29		
7.8 Open-Drain Mode Bus Signal Level.....	29		
7.9 Push-Pull Mode Bus Signal Level — High Voltage e.MMC ...	29		
7.10 Push-Pull Bus Signal Level — Dual Voltage e.MMC ...	29		
8. DC Parameter	30		
8.1 Supply Voltage.....	30		
8.2 Bus Operating Condition.....	30		
9. Ordering Information	31		
10. Physical Diagram	32		
10.1 VFBGA 153 — Package Dimensions 11.5 x 13 x 0.8 mm	32		
10.2 VFBGA 153 — Package Dimensions 11.5 x 13 x 1.0 mm	33		

1. General Description

SkyHigh e.MMC is a managed NAND memory solution designed for embedded applications. SkyHigh e.MMC includes a flash controller and a standard MLC NAND flash memory, and is compatible with the JEDEC JESD84-B51 with backwards compatibility to previous e.MMC specifications.

Designed for faster throughput and large data transfer, SkyHigh e.MMC offers high performance, great reliability, and minimal latency. In addition to higher performance, SkyHigh's e.MMC offers optimum power management features resulting in reduced power consumption, making it an ideal solution for mobile applications.

In addition, highly optimized SkyHigh firmware fully utilizes the MLC NAND capabilities leveraging wear-leveling, defect management, garbage collection, and ECC to enhance product life.

The SkyHigh e.MMC product family offers a vast array of the JEDEC e.MMC features including HS200, HS400, high priority interrupt (HPI), boot partitions, RPMB partitions, background operations, hardware reset, and power off notification.

Combined with an advanced e.MMC feature set and SkyHigh's commitment to quality, SkyHigh e.MMC is ideal for industrial applications as well as set top boxes, gaming consoles, and consumer electronic devices.

2. SkyHigh Product Offering

The SkyHigh e.MMC product offering includes: 4/8/16 GB in 153-FBGA (11.5 mm x 13 mm) packages.

- 8 GB: S40FC008
 - 153 VFBGA (11.5 x 13 x 0.8, 0.5 mm ball pitch)

3. Package Configurations

Figure 3.1 FBGA 153 (Top View, Balls Down)

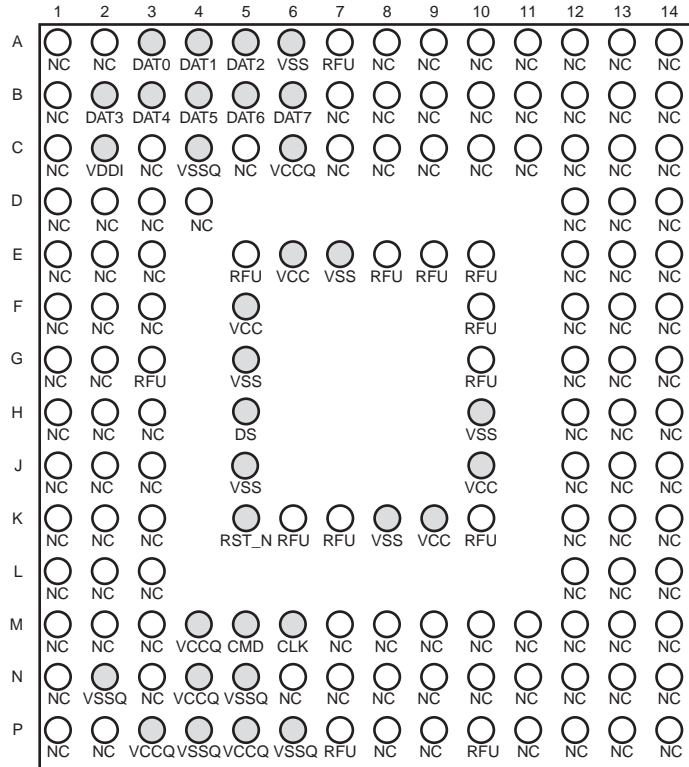

Table 3.1 Pin Description

Pin Name	Type	Description
DAT0 - DAT7	I/O	Bidirectional data channels used for data transfers.
CMD	I/O	Bidirectional command channel used for device initialization and command transfers.
CLK	Input	Clock input.
RST_N	Input	Hardware reset.
VCC	Power	Supply voltage for the flash memory.
VCCQ	Power	Supply voltage for the memory controller and MMC interface.
VDDI	Power	Internal power node. Connect capacitor to ground.
VSS	Power	Ground pin for the flash memory.
VSSQ	Power	Ground pin for the memory controller and MMC interface.
DS	Output	Data strobe.
NC	—	Not connected.
RFU	—	Reserved for future use. Do not connect.

4. Architecture

SkyHigh e.MMC is an embedded non-volatile storage solution with a MultiMediaCard (MMC) interface, a high performance memory controller, and state of the art flash memory all supported by SkyHigh optimized flash management software. Based on the JEDEC industry-standard MMC System Specification v5.1, the SkyHigh e.MMC product family is offered in standard JEDEC BGA packages. Figure 4.1 represents the basic block diagram of the SkyHigh e.MMC.

Figure 4.1 SkyHigh e.MMC Architecture



5. Key Supported e.MMC Features

SkyHigh e.MMC supports the JEDEC JESD84-B51 specification.

5.1 Boot Operation

SkyHigh e.MMC supports boot mode as well as alternate boot mode. Boot operations can be performed at high speed and dual data rate timings.

Figure 5.1 MultiMediaCard State Diagram (Boot Mode)

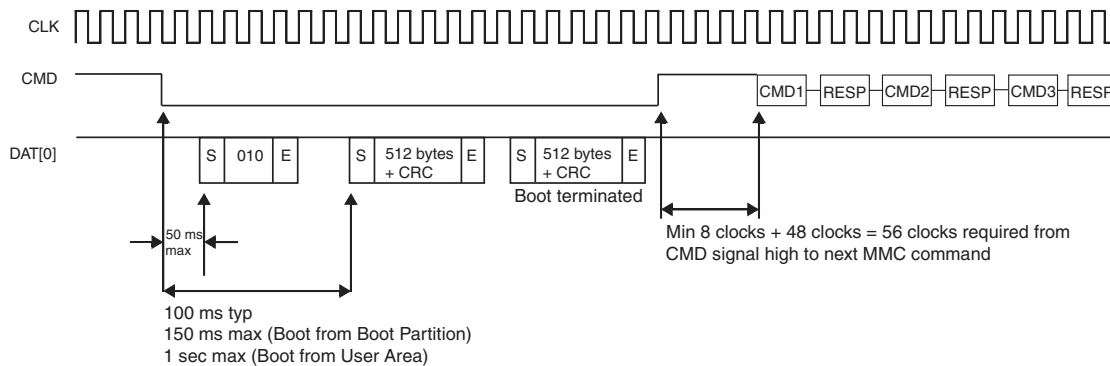
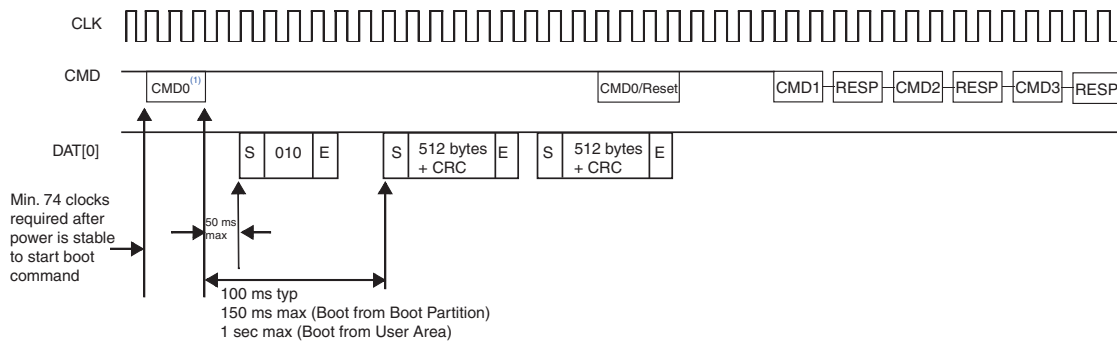

Figure 5.2 MultiMediaCard State Diagram (Alternative Boot Mode)



Note:

1. CMD0 with argument 0xFFFFFFFF.

5.2 Partition Management

e.MMC specifications allow for the device to have the following partitions: a User Data Area for general purpose storage, two boot partitions for storing boot images, and the Replay Protected Memory Block (RPMB) for data management in a replay protected and authenticated manner.

The SkyHigh e.MMC device can be configured as below:

- Factory configuration supplies two boot partitions size of 4 MB each and one RPMB partition size of 4 MB. These partitions are configured in Enhanced (SLC) mode for higher reliability.
- The host can create up to four General Purpose Partitions within the User Data Area. These partitions can be configured in Enhanced (SLC) mode or Default (MLC) mode. The host will also need to configure the size of each partition. These attributes can be programmed by the host only once in the device life-cycle (one-time programmable).
- In addition to the General Purpose Partitions the host can also configure a segment of the User Data Area to be accessed in Enhanced (SLC) mode. The host will need to specify the starting location and size. These attributes can be programmed by the host only once in the device life-cycle (one-time programmable).

Table 5.1 Partition Type

Partition		NAND Mode
Boot Area 1		SLC Mode
Boot Area 2		SLC Mode
RPMB Area		SLC Mode
User Data Area	General Purpose Partition	MLC or SLC Mode
	Enhanced	SLC Mode
	Default	MLC Mode

Figure 5.3 Partitions

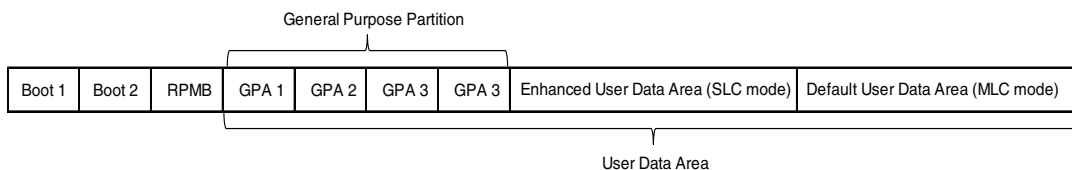

5.3 Sleep (CMD5)

Sleep/Awake (CMD5) is used to switch the device between Sleep and Standby mode. During the Sleep state, V_{CC} can be switched off for maximum power savings. While a device is in Sleep mode it can only respond to the Reset (CMD0) and Sleep/Awake (CMD5) commands.

5.4 High Priority Interrupt (HPI)

High Priority Interrupt (HPI) is intended to suspend an ongoing operation while allowing for a high priority read operation to be performed.

5.5 Background Operations

e.MMC devices are equipped with a Background Operations feature. When enabled, BackgroundOperations allow the e.MMC device to perform a number of routine data maintenance operations such as wear leveling, garbage collection, erase, and compaction while the host CPU is not being serviced.

5.6 Auto Background Operations

Auto Background Operations is a feature that allows the e.MMC device to fully manage background operations without any requirements from the Host. The e.MMC device will check if background operations are required at specified intervals and initiate background operations if needed. This frees the host from having to develop software to manage these maintenance tasks and ensure that the e.MMC device is operating at the optimum performance levels. Issuing any command while auto background operations are occurring will stop the current background operation activities. There will be a maximum latency of 40 ms if auto background operations are interrupted by any read or write command from the host.

5.7 Trim

Similar to the Erase operation, the Trim function performs a targeted erase on specific write blocks. Data that is no longer needed, designated by the host, will be erased during background erase events.

5.8 Sanitize

Sanitize is intended for applications with high security requirements that can afford the performance impact. This command is used in conjunction with standard Erase or Trim operations and requires the device to physically remove data from the unmapped user address space. The busy line will be asserted once the Sanitize operations begin and will remain busy until the operation has been completed or interrupted.

5.9 Hardware Reset

Used by the host to reset the device, hardware reset moves the device into a pre-idle state and disables the power-on period write protection on blocks that were set at power-on as write protected.

5.10 Health Monitoring

Health Monitoring is a proprietary feature of the SkyHigh e.MMC product that provides useful information about the life span of the NAND flash component. The host can query for the device’s health by using the CMD60 command to get information such as the number of bad blocks and the number of erase cycles for each block. EXT_CSD registers [269:254] also contain valuable device health information. A separate application note is available with the full details of the CMD60 command and EXT_CSD registers [269:254]. A non-disclosure agreement (NDA) is required to view this application note. Contact your nearest SkyHigh sales office for more information.

5.11 Field Firmware Update

Field Firmware Update is a feature that allows the host to upload a new version of the firmware to the e.MMC. This can be done by setting the device into FFU mode and performing writes with the arguments defined in the FFU_ARG register. A separate application note is available with the full details of this feature. A non-disclosure agreement (NDA) is required to view this application note. Contact your nearest SkyHigh sales office for more information.

6. Register Values

6.1 OCR Register

Operation Conditions Register (OCR) stores the e.MMC voltage profile. In addition, it contains the status bit (31) which is set when the device power up has been completed.

Table 6.1 OCR Register

Field Description	OCR Slice	Value
Reserved	[6:0]	00 00000b
V _{CCQ} : 1.7 - 1.95 range	[7]	Dual Voltage: 1b
V _{CCQ} : 2.0 - 2.6 range	[14:8]	000 0000b
V _{CCQ} : 2.7 - 3.6 range	[23:15]	1 1111 1111b
Reserved	[28:24]	0 0000b
Access Mode	[30:29]	Sector Mode: 10b
e.MMC power up status bit (busy) (1)	[31]	—

Notes:

1. Bit 31 is set to LOW if device is not finished with the power up routine.
2. The voltage for internal flash memory (V_{CC}) should be 2.7V - 3.6V regardless of OCR Register value.

6.2 CID Register

The Card Identification Register (CID) contains the card identification information used during the card identification phase.

Table 6.2 CID Register

Field Name	Field ID	Width	CID slice	CID Value
Manufacturer ID	MID	8	[127:120]	01h
Card BGA	CBX	2	[113:112]	01b
OEM/Application ID	OID	8	[111:104]	00h
Product Name	PNM	48	[103:56]	See product table
Product Revision	PRV	8	[55:48]	(Note3)
Product Serial Number	PSN	32	[47:16]	32-bit unsigned binary integer assigned at random
Manufacturing Date	MDT	8	[15:8]	(Note 1)
CRC7 Checksum	CRC	7	[7:1]	(Note 2)
Not Used	—	1	[0]	Always 1

Notes:

1. Descriptions follow JEDEC e.MMC Standard Specifications.
2. The CRC7 checksum (7 bits). This is the checksum of the CID contents computed according to 0.
3. Product Revision is a combination of Controller and Firmware Revisions.

6.3 Product Table

Table 6.3 Product Table

SkyHigh Part Number	Density	Product Name in CID Register (PNM)
S40FC008	8 GB	"S40008" – 533430303038h

6.4 Card Specific Data Register

Card Specific Data (CSD) Register contains the eMMC access information. It includes data format, error correction, transfer speeds, and access times. It also includes information as to whether the DSR register can be accessed.

Table 6. CSD Register

Field Name	Field ID	Size (Bits)	Cell Type	CSD Slice	CSD Value
CSD Structure	CSD_STRUCTURE	2	R	[127:126]	3h
System Specification Version	SPEC_VERS	4	R	[125:122]	4h
Reserved ^[1]	—	2	R	[121:120]	—
Data Read Access Time 1	TAAC	8	R	[119:112]	27h
Data Read Access Time 2 in CLK cycles (NSAC*100)	NSAC	8	R	[111:104]	01h
Maximum Bus Clock Frequency	TRAN_SPEED	8	R	[103:96]	32h
Device Command Classes	CCC	12	R	[95:84]	0F5h
Maximum Read Block Length	READ_BL_LEN	4	R	[83:80]	9h
Partial Blocks For Read Allowed	READ_BL_PARTIAL	1	R	[79:79]	0h
Write Block Misalignment	WRITE_BLK_MISALIGN	1	R	[78:78]	0h
Read Block Misalignment	READ_BLK_MISALIGN	1	R	[77:77]	0h
DSR Implemented	DSR_IMP	1	R	[76:76]	0h
Reserved ^[1]	—	2	R	[75:74]	—
Device Size	*C_SIZE	12	R	[73:62]	FFFh
Maximum Read Current at V _{DD} min	VDD_R_CURR_MIN	3	R	[61:59]	7h
Maximum Read Current at V _{DD} max	VDD_R_CURR_MAX	3	R	[58:56]	7h
Maximum Write Current at V _{DD} min	VDD_W_CURR_MIN	3	R	[55:53]	7h
Maximum Write Current at V _{DD} max	VDD_W_CURR_MAX	3	R	[52:50]	7h
Device Size Multiplier	C_SIZE_MULT	3	R	[49:47]	7h
Erase Group Size	ERASE_GRP_SIZE	5	R	[46:42]	1Fh
Erase Group Size Multiplier	ERASE_GRP_MULT	5	R	[41:37]	1Fh
Write Protect Group Size	WP_GRP_SIZE	5	R	[36:32]	0Fh
Write Protect Group Enable	WP_GRP_ENABLE	1	R	[31:31]	1h
Manufacturer Default	DEFAULT_ECC	2	R	[30:29]	0h
Write Speed Factor	R2W_FACTOR	3	R	[28:26]	2h
Maximum Write Data Block Length	WRITE_BL_LEN	4	R	[25:22]	9h
Partial Blocks For Write Allowed	WRITE_BL_PARTIAL	1	R	[21:21]	0h
Reserved ^[1]	—	4	R	[20:17]	—
Content Protection Application	CONTENT_PROT_APP	1	R	[16:16]	0h
File Format Group	FILE_FORMAT_GRP	1	R/W	[15:15]	0h
Copy Flag (OTP)	COPY	1	R/W	[14:14]	1h
Permanent Write Protection	PERM_WRITE_PROTECT	1	R/W	[13:13]	0h

Notes

1. Reserved bits should be read at '0'.
2. R = Read only. R/W = One time programmable and readable. R/W/E = Multiple writable with value kept after power failure, hardware reset assertion and any CMD0 reset and readable.
3. V_{DD} represents the total consumed current for V_{CC} and V_{CCQ}.

Table 6. CSD Register (Continued)

Field Name	Field ID	Size (Bits)	Cell Type	CSD Slice	CSD Value
Temporary Write Protection	TMP_WRITE_PROTECT	1	R/W/E	[12:12]	0h
File Format	FILE_FORMAT	2	R/W	[11:10]	0h
ECC Code	ECC	2	R/W/E	[9:8]	0h
Calculated CRC	CRC	7	R/W/E	[7:1]	NOTE 4
Not Used	—	1	—	[0]	Always 1

Notes

- Reserved bits should be read at '0'.
- R = Read only. R/W = One time programmable and readable. R/W/E = Multiple writable with value kept after power failure, hardware reset assertion and any CMD0 reset and readable.
- V_{DD} represents the total consumed current for V_{CC} and V_{CCQ}.
- The CRC field carries the check sum for the CSD contents. It is computed according to 0. The checksum has to be recalculated by the host for any CSD modification. The default corresponds to the initial CSD contents.

6.5 Extended CSD Register (EXT_CSD)

The Extended CSD Register defines the e.MMC selected modes and properties. It is 512 bytes long. The most significant 320 bytes, also know as Properties segment, define the e.MMC capabilities and cannot be modified by the host. The remaining 192 bytes define e.MMC operating modes and can be modified by the host via a Switch command.

Table 7. Extended CSD Register (EXT_CSD)

Field Name	Field ID	Size (Bytes)	Cell Type	EXT_CSD Slice	Value
Reserved ^[5]	—	6	—	[511:506]	—
Extended Security Commands Error	EXT_SECURITY_ERR	1	R	[505]	00h
Supported Command Sets	S_CMD_SET	1	R	[504]	01h
HPI Features	HPI_FEATURES	1	R	[503]	01h
Background Operations Support	BKOPS_SUPPORT	1	R	[502]	01h
Max Packed Read Commands	MAX_PACKED_READS	1	R	[501]	20h
Max Packed Write Commands	MAX_PACKED_WRITES	1	R	[500]	20h
Data Tag Support	DATA_TAG_SUPPORT	1	R	[499]	01h
Tag Unit Size	TAG_UNIT_SIZE	1	R	[498]	00h
Tag Resources Size	TAG_RES_SIZE	1	R	[497]	00h
Context Management Capabilities	CONTEXT_CAPABILITIES	1	R	[496]	78h
Large Unit Size	LARGE_UNIT_SIZE_M1	1	R	[495]	01h
Extended Partitions Attribute Support	EXT_SUPPORT	1	R	[494]	03h
Supported Modes	SUPPORTED_MODES	1	R	[493]	01h
FFU Features	FFU_FEATURES	1	R	[492]	00h
Operation Codes Timeout	OPERATION_CODE_TIMEOUT	1	R	[491]	17h

Notes

- Reserved bits should be read at 0, unless otherwise specified.
- Set to 0 after power on, hardware reset or software reset selecting backward compatibility interface timings. If the host changes the value to 1, the device will operate in high-speed mode and finally, if host changes the value to 2, HS200 interface timings will be used.
- Set to 0 after power up and can be changed via a Switch command.
- R = Read only.
R/W = One time programmable and readable.
R/W/E = Multiple writable with value kept after power failure, hardware reset assertion and any CMD0 reset and readable.
R/W/C_P = Writable after value cleared by power failure and hardware reset assertion (the value not cleared by CMD0 reset) and readable.
R/W/E_P = Multiple writable with value reset after power failure, hardware reset assertion and any CMD0 reset and readable.
W/E_P = Multiple writable with value reset after power failure, hardware reset assertion and any CMD0 reset and not readable.
- Value depends on state of the device.
- Value depends on the firmware that the device is loaded with.

Table 7. Extended CSD Register (EXT_CSD) (Continued)

Field Name	Field ID	Size (Bytes)	Cell Type	EXT_CSD Slice	Value
FFU Argument	FFU_ARG	4	R	[490:487]	FFFAFFF0h
Barrier support	BARRIER_SUPPORT	1	R	486	1h
Reserved ^[5]		181	—	[485:309]	—
CMD Queuing Support	CMDQ_SUPPORT	1	R	308	1h
CMD Queuing Depth	CMDQ_DEPTH	1	R	307	1Fh
Reserved ^[5]		1	—	306	—
Number of FW Sectors Correctly Programmed	NUMBER_OF_FW_SECTORS_CORRECTLY_PROGRAMMED	4	R	[305:302]	0000h
Vendor proprietary health report ^[11]	VENDOR_PROPRIETARY_HEALTH_REPORT	32	R	[301:270]	N/A
Device Life Time Estimation Type B	DEVICE_LIFE_TIME_EST_TYP_B	1	R	[269]	01h
Device Life Time Estimation Type A	DEVICE_LIFE_TIME_EST_TYP_A	1	R	[268]	01h
Pre-EOL Information ^[9]	PRE_EOL_INFO	1	R	[267]	01h
Optimal Read Size	OPTIMAL_READ_SIZE	1	R	[266]	40h
Optimal Write Size	OPTIMAL_WRITE_SIZE	1	R	[265]	40h
Optimal Trim Unit Size	OPTIMAL_TRIM_UNIT_SIZE	1	R	[264]	07h
Device Version	DEVICE_VERSION	2	R	[263:262]	3805h
Firmware Version ^[10]	FIRMWARE_VERSION	8	R	[261:254]	—
Power class for 200MHz, DDR at VCC= 3.6V	PWR_CL_DDR_200_360	1	R	[253]	00h
Cache Size	CACHE_SIZE	4	R	[252:249]	0400h
Generic CMD6 Timeout	GENERIC_CMD6_TIME	1	R	[248]	05h
Power Off Notification (Long) Timeout	POWER_OFF_LONG_TIME	1	R	[247]	64h
Background Operations Status	BKOPS_STATUS	1	R	[246]	00h
Number Of Correctly Programmed Sectors	CORRECTLY_PRG_SECTORS_NUM	4	R	[245:242]	0000h
1st Initialization Time after Partitioning	INI_TIMEOUT_PA	1	R	[241]	0Ah
Cache Flushing Policy	CACHE_FLUSH_POLICY	1	R	[240]	01h
Power Class for 52 MHz, DDR at 3.6 V	PWR_CL_DDR_52_360	1	R	[239]	00h
Power Class for 52 MHz, DDR at 1.95 V	PWR_CL_DDR_52_195	1	R	[238]	00h
Power Class for 200 MHz at 1.95 V	PWR_CL_200_195	1	R	[237]	00h
Power Class for 200 MHz at 1.30 V	PWR_CL_200_130	1	R	[236]	00h
Minimum Write Performance for 8-bit at 52 MHz in DDR mode	MIN_PERF_DDR_W_8_52	1	R	[235]	00h
Minimum Read Performance for 8-bit at 52 MHz in DDR mode	MIN_PERF_DDR_R_8_52	1	R	[234]	00h
Reserved ^[5]	—	1	—	[233]	—

Notes

5. Reserved bits should be read at 0, unless otherwise specified.
6. Set to 0 after power on, hardware reset or software reset selecting backward compatibility interface timings. If the host changes the value to 1, the device will operate in high-speed mode and finally, if host changes the value to 2, HS200 interface timings will be used.
7. Set to 0 after power up and can be changed via a Switch command.
8. R = Read only.
R/W = One time programmable and readable.
R/W/E = Multiple writable with value kept after power failure, hardware reset assertion and any CMD0 reset and readable.
R/W/C_P = Writable after value cleared by power failure and hardware reset assertion (the value not cleared by CMD0 reset) and readable.
R/W/E_P = Multiple writable with value reset after power failure, hardware reset assertion and any CMD0 reset and readable.
W/E_P = Multiple writable with value reset after power failure, hardware reset assertion and any CMD0 reset and not readable.
9. Value depends on state of the device.
10. Value depends on the firmware that the device is loaded with. ExtCSD[254] = PRV value in CID register Others are zero
11. This Fields reserved for vendor proprietary health report.

Table 7. Extended CSD Register (EXT_CSD) (Continued)

Field Name	Field ID	Size (Bytes)	Cell Type	EXT_CSD Slice	Value
Trim Multiplier	TRIM_MULT	1	R	[232]	02h
Secure Feature Support	SEC_FEATURE_SUPPORT	1	R	[231]	55h
Secure Erase Multiplier	SEC_ERASE_MULT	1	R	[230]	19h
Secure TRIM Multiplier	SEC_TRIM_MULT	1	R	[229]	0Ah
Boot Information	BOOT_INFO	1	R	[228]	07h
Reserved ⁵⁾	—	1	—	[227]	—
Boot Partition Size	BOOT_SIZE_MULT	1	R	[226]	20h
Access Size	ACC_SIZE	1	R	[225]	06h
High Capacity Erase Unit Size	HC_ERASE_GRP_SIZE	1	R	[224]	01h
High Capacity Erase Time Out	ERASE_TIMEOUT_MULT	1	R	[223]	02h
Reliable Write Sector Count	REL_WR_SEC_C	1	R	[222]	01h
High Capacity Write Protect Group Size	HC_WP_GRP_SIZE	1	R	[221]	10h
Sleep Current [V _{CC}]	S_C_VCC	1	R	[220]	07h
Sleep Current [V _{CCQ}]	S_C_VCCQ	1	R	[219]	07h
Production State Awareness Timeout	PRODUCTION_STATE_AWARENESS_TIMEOUT	1	R	[218]	17h
Sleep/awake Time Out	S_A_TIMEOUT	1	R	[217]	12h
Sleep Notification Timeout	SLLEP_NOTIFICATION_TIME	1	R	[216]	0Ch
Sector Count	SEC_COUNT	4	R	[215:212]	00E90000h
Secure Write Protect Information	SECURE_WP_INFO	1	R	[211]	01h
Minimum Write Performance for 8-bit at 52 MHz	MIN_PERF_W_8_52	1	R	[210]	0h
Minimum Read Performance for 8-bit at 52 MHz	MIN_PERF_R_8_52	1	R	[209]	0h
Minimum Write Performance for 4-bit at 52 MHz or 8-bit at 26 MHz	MIN_PERF_W_8_26_4_52	1	R	[208]	0h
Minimum Read Performance for 4-bit at 52 MHz or 8-bit at 26 MHz	MIN_PERF_R_8_26_4_52	1	R	[207]	0h
Minimum Write Performance for 4-bit at 26 MHz	MIN_PERF_W_4_26	1	R	[206]	0h

Notes

5. Reserved bits should be read at 0, unless otherwise specified.
6. Set to 0 after power on, hardware reset or software reset selecting backward compatibility interface timings. If the host changes the value to 1, the device will operate in high-speed mode and finally, if host changes the value to 2, HS200 interface timings will be used.
7. Set to 0 after power up and can be changed via a Switch command.
8. R = Read only.
R/W = One time programmable and readable.
R/W/E = Multiple writable with value kept after power failure, hardware reset assertion and any CMD0 reset and readable.
R/W/C_P = Writable after value cleared by power failure and hardware reset assertion (the value not cleared by CMD0 reset) and readable.
R/W/E_P = Multiple writable with value reset after power failure, hardware reset assertion and any CMD0 reset and readable.
W/E_P = Multiple writable with value reset after power failure, hardware reset assertion and any CMD0 reset and not readable.
9. Value depends on state of the device.
10. Value depends on the firmware that the device is loaded with.

Table 7. Extended CSD Register (EXT_CSD) (Continued)

Field Name	Field ID	Size (Bytes)	Cell Type	EXT_CSD Slice	Value
Minimum Read Performance for 4-bit at 26 MHz	MIN_PERF_R_4_26	1	R	[205]	0h
Reserved ^[5]	—	1	—	[204]	—
Power Class for 26 MHz at 3.6 V	PWR_CL_26_360	1	R	[203]	0h
Power Class for 52 MHz at 3.6 V	PWR_CL_52_360	1	R	[202]	0h
Power Class for 26 MHz at 1.95 V	PWR_CL_26_195	1	R	[201]	0h
Power Class for 52 MHz at 1.95 V	PWR_CL_52_195	1	R	[200]	0h
Partition Switching Timing	PARTITION_SWITCH_TIME	1	R	[199]	04h
Out-of-Interrupt Busy Timing	OUT_OF_INTERRUPT_TIME	1	R	[198]	0Ah
I/O Driver Strength	DRIVER_STRENGTH	1	R	[197]	1Fh
Device Type	CARD_TYPE	1	R	[196]	57h
Reserved ^[5]	—	1	—	[195]	—
CSD Structure Version	CSD_STRUCTURE	1	R	[194]	2h
Reserved ^[5]	—	1	—	[193]	—
Extended CSD Revision	EXT_CSD_REV	1	R	[192]	8h
Command Set	CMD_SET	1	R/W/E_P	[191]	0h
Reserved ^[5]	—	1	—	[190]	—
Command Set Revision	CMD_SET_REV	1	R	[189]	0h
Reserved ^[5]	—	1	—	[188]	—
Power Class	POWER_CLASS	1	R/W/E_P	[187]	0h
Reserved ^[5]	—	1	—	[186]	—
High Speed Interface Timing ^[6]	HS_TIMING	1	R/W/E_P	[185]	0h
Strobe Support	STROBE_SUPPORT	1	R	[184]	1h
Bus Width Mode ^[7]	BUS_WIDTH	1	W/E_P	[183]	0h
Reserved ^[5]	—	1	—	[182]	—
Erased Memory Content	ERASED_MEM_CONT	1	R	[181]	0h
Reserved ^[5]	—	1	—	[180]	—
Partition Configuration	PARTITION_CONFIG	1	R/W/E, R/W/E_P	[179]	0h
Boot Config Protection	BOOT_CONFIG_PROT	1	R/W, R/W/C_P	[178]	0h
Boot Bus Conditions	BOOT_BUS_WIDTH	1	R/W/E	[177]	0h
Reserved ^[5]	—	1	—	[176]	—
High-Density Erase Group Definition	ERASE_GROUP_DEF	1	R/W/E_P	[175]	0h

Notes

5. Reserved bits should be read at 0, unless otherwise specified.
6. Set to 0 after power on, hardware reset or software reset selecting backward compatibility interface timings. If the host changes the value to 1, the device will operate in high-speed mode and finally, if host changes the value to 2, HS200 interface timings will be used.
7. Set to 0 after power up and can be changed via a Switch command.
8. R = Read only.
R/W = One time programmable and readable.
R/W/E = Multiple writable with value kept after power failure, hardware reset assertion and any CMD0 reset and readable.
R/W/C_P = Writable after value cleared by power failure and hardware reset assertion (the value not cleared by CMD0 reset) and readable.
R/W/E_P = Multiple writable with value reset after power failure, hardware reset assertion and any CMD0 reset and readable.
W/E_P = Multiple writable with value reset after power failure, hardware reset assertion and any CMD0 reset and not readable.
9. Value depends on state of the device.
10. Value depends on the firmware that the device is loaded with.

Table 7. Extended CSD Register (EXT_CSD) (Continued)

Field Name	Field ID	Size (Bytes)	Cell Type	EXT_CSD Slice	Value
Boot Write Protection Status Register	BOOT_WP_STATUS	1	R	[174]	0h
Boot Area Write Protect Register	BOOT_WP	1	R/W, R/W/C_P	[173]	0h
Reserved ^[5]	—	1	—	[172]	—
User Area Write Protect Register	USER_WP	1	R/W, R/W/C_P, R/W/E_P	[171]	0h
Reserved ^[5]	—	1	—	[170]	—
FW Configuration	FW_CONFIG	1	R/W	[169]	0h
RPMB Size	RPMB_SIZE_MULT	1	R	[168]	20h
Write Reliability Setting Register	WR_REL_SET	1	R/W	[167]	1Fh
Write Reliability Parameter Register	WR_REL_PARAM	1	R	[166]	15h
Start Sanitize Operation	SANITIZE_START	1	W/E_P	[165]	00h
Manually Start Background Operations	BKOPS_START	1	W/E_P	[164]	00h
Enable Background Operations Handshake	BKOPS_EN	1	R/W	[163]	02h
Hardware Reset Function	RST_n_FUNCTION	1	R/W	[162]	00h
HPI Management	HPI_MGMT	1	R/W/E_P	[161]	00h
Partitioning Support	PARTITIONING_SUPPORT	1	R	[160]	07h
Max Enhanced Area Size	MAX_ENH_SIZE_MULT	3	R	[159:157]	0001D2h
Partitions Attribute	PARTITIONS_ATTRIBUTE	1	R/W	[156]	00h
Partitioning Setting	PARTITION_SETTING_COMPLETED	1	R/W	[155]	00h
General Purpose Partition Size	GP_SIZE_MULT	12	R/W	[154:143]	00...00h
Enhanced User Data Area Size	ENH_SIZE_MULT	3	R/W	[142:140]	000h
Enhanced User Data Start Address	ENH_START_ADDR	4	R/W	[139:136]	0000h
Reserved ^[5]	—	1	—	[135]	—
Secure Bad Block Management	SEC_BAD_BLK_MGMNT	1	R/W	[134]	00h
Production State Awareness	PRODUCTION_STATE_AWARENESS	1	R/W/E	[133]	00h
Package Case Temperature is Controlled	TCASE_SUPPORT	1	W/E_P	[132]	00h
Periodic Wakeup	PERIODIC_WAKEUP	1	R/W/E	[131]	00h
Program CID/CSD in DDR Mode Support	PROGRAM_CID_CSD_DDR_SUPPORT	1	R	[130]	01h
Reserved ^[5]	—	2	—	[129:128]	—

Notes

5. Reserved bits should be read at 0, unless otherwise specified.
6. Set to 0 after power on, hardware reset or software reset selecting backward compatibility interface timings. If the host changes the value to 1, the device will operate in high-speed mode and finally, if host changes the value to 2, HS200 interface timings will be used.
7. Set to 0 after power up and can be changed via a Switch command.
8. R = Read only.
R/W = One time programmable and readable.
R/W/E = Multiple writable with value kept after power failure, hardware reset assertion and any CMD0 reset and readable.
R/W/C_P = Writable after value cleared by power failure and hardware reset assertion (the value not cleared by CMD0 reset) and readable.
R/W/E_P = Multiple writable with value reset after power failure, hardware reset assertion and any CMD0 reset and readable.
W/E_P = Multiple writable with value reset after power failure, hardware reset assertion and any CMD0 reset and not readable.
9. Value depends on state of the device.
10. Value depends on the firmware that the device is loaded with.

Table 7. Extended CSD Register (EXT_CSD) (Continued)

Field Name	Field ID	Size (Bytes)	Cell Type	EXT_CSD Slice	Value
Vendor Specific Fields ^[12]	VENDOR_SPECIFIC_FIELD	64	<vendor specific>	[127:64]	N/A
Native Sector Size	NATIVE_SECTOR_SIZE	1	R	[63]	1h
Sector Size Emulation	USE_NATIVE_SECTOR	1	R/W	[62]	0h
Sector Size	DATA_SECTOR_SIZE	1	R	[61]	0h
1st Initialization After Disabling Sector Size Emulation	INI_TIMEOUT_EMU	1	R	[60]	0Ah
Class 6 Command Control	CLASS_6_CTRL	1	R/W/E_P	[59]	0h
Number Of Address Group To Be Released	DYNCAP_NEEDED	1	R	[58]	0h
Exception Events Control	EXCEPTION_EVENTS_CTRL	2	R/W/E_P	[57:56]	00h
Exception Events Status	EXCEPTION_EVENTS_STATUS	2	R	[55:54]	00h
Extended Partitions Attribute	EXT_PARTITIONS_ATTRIBUTE	2	R/W	[53:52]	00h
Context Configuration	CONTEXT_CONF	15	R/W/E_P	[51:37]	00...00h
Packed Command Status	PACKED_COMMAND_STATUS	1	R	[36]	0h
Packed Command Failure Index	PACKED_FAILURE_INDEX	1	R	[35]	0h
Power Off Notification	POWER_OFF_NOTIFICATION	1	R/W/E_P	[34]	0h
Control to Turn the Cache On/Off	CACHE_CTRL	1	R/W/E_P	[33]	0h
Flushing of the Cache	FLUSH_CACHE	1	W/E_P	[32]	0h
Control to turn the Barrier ON/OFF	BARRIEIR_CNTL	1	R/W	[31]	0h
Mode Config	MODE_CONFIG	1	R/W/E_P	[30]	0h
Mode Operation Codes	MODE_OPERATION_CODES	1	W/E_P	[29]	0h
Reserved ^[5]		2	—	[28:27]	—
FFU Status	FFU_STATUS	1	R	[26]	0h
Pre Loading Data Size	PRE_LOADING_DATA_SIZE	4	R/W/E_P	[25:22]	0000h
Max Pre Loading Data Size	MAX_PRE_LOADING_DATA_SIZE	4	R	[21:18]	0x00E90000
Production State Awareness Enablement	PRODUCT_STATE_AWARENESS_ENABLEMENT	1	R/W/E and R	[17]	01h
Secure Removal Type	SECURE_REMOVAL_TYPE	1	R/W & R	[16]	3Bh
Command Queue Mode Enable	CMDQ_MODE_EN	1	R/W/E_P	[15]	0h
Reserved ^[5]		15	—	[14:0]	—

Notes

5. Reserved bits should be read at 0, unless otherwise specified.
6. Set to 0 after power on, hardware reset or software reset selecting backward compatibility interface timings. If the host changes the value to 1, the device will operate in high-speed mode and finally, if host changes the value to 2, HS200 interface timings will be used.
7. Set to 0 after power up and can be changed via a Switch command.
8. R = Read only.
R/W = One time programmable and readable.
R/W/E = Multiple writable with value kept after power failure, hardware reset assertion and any CMD0 reset and readable.
R/W/C_P = Writable after value cleared by power failure and hardware reset assertion (the value not cleared by CMD0 reset) and readable.
R/W/E_P = Multiple writable with value reset after power failure, hardware reset assertion and any CMD0 reset and readable.
W/E_P = Multiple writable with value reset after power failure, hardware reset assertion and any CMD0 reset and not readable.
9. Value depends on state of the device.
10. Value depends on the firmware that the device is loaded with.
12. These fields are reserved for definition by the device manufacturer

7. AC Parameter

7.1 Bus Timing

Figure 7.1 Bus Timing Diagram

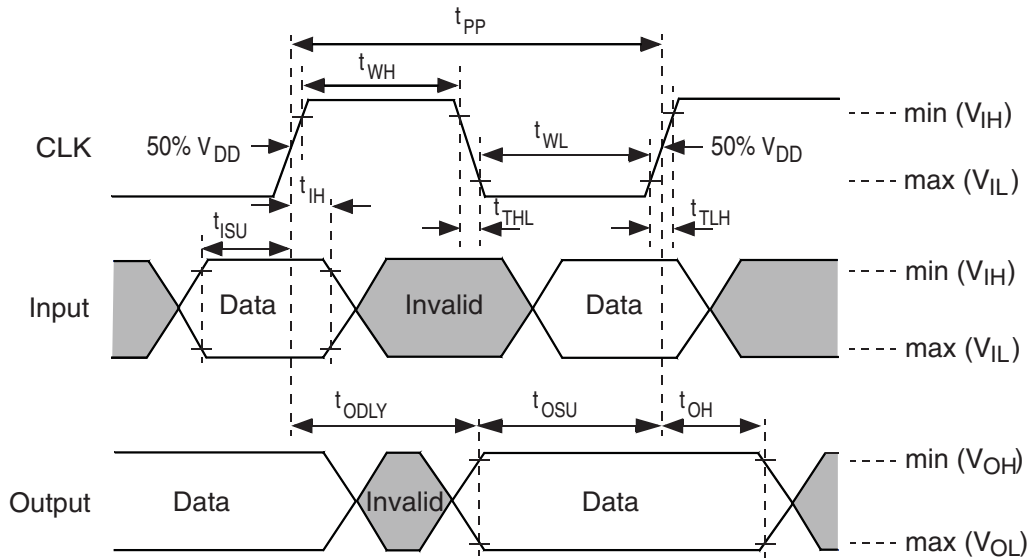

Note:

1. Data must always be sampled on the rising edge of the clock.

7.2 High Speed Timing

Table 7.1 High Speed Timing

Parameter	Symbol	Min	Max	Unit	Remark
Clock CLK					
Clock Frequency Data Transfer Mode	f_{PP}	0	52	MHz	CL \leq 30 pF Tolerance: +100 kHz
Clock Frequency Identification Mode	f_{OD}	0	400	kHz	Tolerance: +20 kHz
Clock Low Time	t_{WL}	6.5		ns	CL \leq 30 pF
Clock High Time	t_{WH}	6.5		ns	CL \leq 30 pF
Clock Rise Time	t_{TLH}		3	ns	CL \leq 30 pF
Clock Fall Time	t_{THL}		3	ns	CL \leq 30 pF
Inputs CMD, DAT (referenced to CLK)					
Input Set-up Time	t_{ISU}	3		ns	CL \leq 30 pF
Input Hold Time	t_{IH}	3		ns	CL \leq 30 pF
Outputs CMD, DAT (referenced to CLK)					
Output Delay Time During Data Transfer Mode	t_{ODLY}		13.7	ns	CL \leq 30 pF
Output Hold Time	t_{OH}	2.5			CL \leq 30 pF
Signal Rise Time	t_{RISE}		3	ns	CL \leq 30 pF
Signal Fall Time	t_{FALL}		3	ns	CL \leq 30 pF

7.3 Backward Compatible Timing

Table 7.2 Backward Compatible Timing

Parameter	Symbol	Min	Max	Unit	Remark
Clock CLK					
Clock Frequency Data Transfer Mode	f_{PP}	0	26	MHz	CL \leq 30 pF
Clock Frequency Identification Mode	f_{OD}	0	400	kHz	
Clock Low Time	t_{WL}	10		ns	CL \leq 30 pF
Clock High Time	t_{WH}	10			
Clock Rise Time	t_{TLH}		10	ns	CL \leq 30 pF
Clock Fall Time	t_{THL}		10	ns	CL \leq 30 pF
Inputs CMD, DAT (referenced to CLK)					
Input Set-Up Time	t_{ISU}	3		ns	CL \leq 30 pF
Input Hold Time	t_{IH}	3		ns	CL \leq 30 pF
Outputs CMD, DAT (referenced to CLK)					
Output Hold Time	t_{OH}	8.3		ns	CL \leq 30 pF
Output Set-up Time	t_{OSU}	11.7		ns	CL \leq 30 pF

7.4 DDR Interface Timing

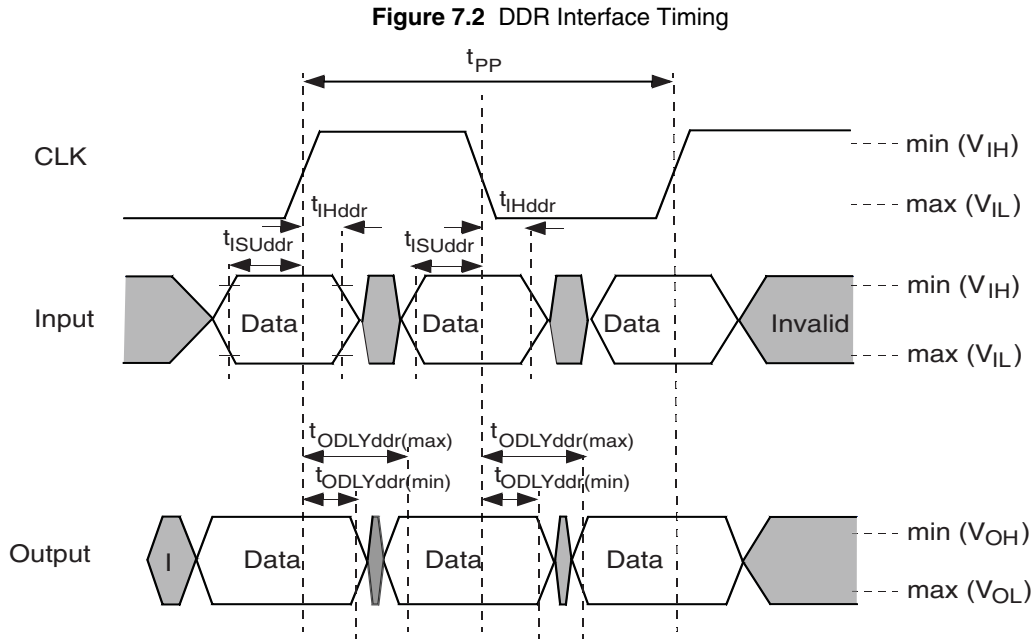

Table 7.3 DDR Interface Timing

Parameter	Symbol	Min	Max.	Unit	Remark
Input CLK1					
Clock Duty Cycle		45	55	%	Includes jitter, phase noise
Input DAT (referenced to CLK-DDR mode)					
Input Set-up Time	t_{SUddr}	2.5		ns	$CL \leq 20$ pF
Input Hold Time	t_{IHddr}	2.5		ns	$CL \leq 20$ pF
Output DAT (referenced to CLK-DDR mode)					
Output Delay Time During Data Transfer	$t_{ODLYddr}$	1.5	7	ns	$CL \leq 20$ pF
Signal Rise Time (All Signals)	t_{RISE}		2	ns	$CL \leq 20$ pF
Signal Fall Time (All Signals)	t_{FALL}		2	ns	$CL \leq 20$ pF

7.5 Timing Specifications for HS200 Mode

7.5.1 HS200 Clock Timing

HS200 mode is available when V_{CCQ} is 1.7V to 1.95V, and the clock timing should conform with the timing diagram shown in [Figure 7.3](#). CLK input timings need to meet the clock timing across the entire range of operating environment. CLK timings must be measured while CMD and DAT signals are either high or low. HS200 supports clock frequencies of up to 200 MHz.

Figure 7.3 HS200 Clock Signal Timing

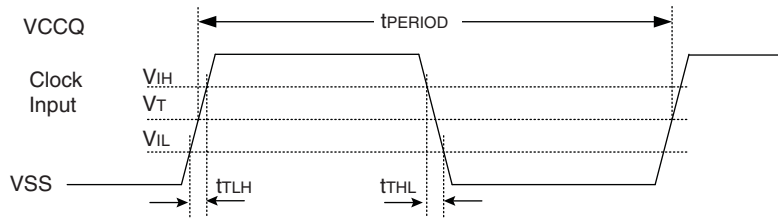

Notes:

1. V_{IH} denotes $V_{IH(min.)}$, and V_{IL} denotes $V_{IL(max.)}$.
2. $V_T = 0.975V$, Clock Threshold ($V_{CCQ} = 1.8V$); indicates reference points for timing measurements.

Table 7.4 HS200 Clock Signal Timing

Symbol	Min.	Max.	Unit	Remark
t_{PERIOD}	5	—	ns	200 MHz (max.) between rising edges.
t_{TLH}, t_{THL}	—	$0.2 t_{PERIOD}$	ns	$t_{TLH}, t_{THL} < 1\text{ ns (max.)}$ at 200 MHz, CBGA = 12 pF. The absolute max. value of t_{TLH}, t_{THL} is 10 ns regardless of clock frequency.
Duty Cycle	30	70	%	

7.5.2 HS200 Input Timing

Figure 7.4 HS200 Device Input Timing

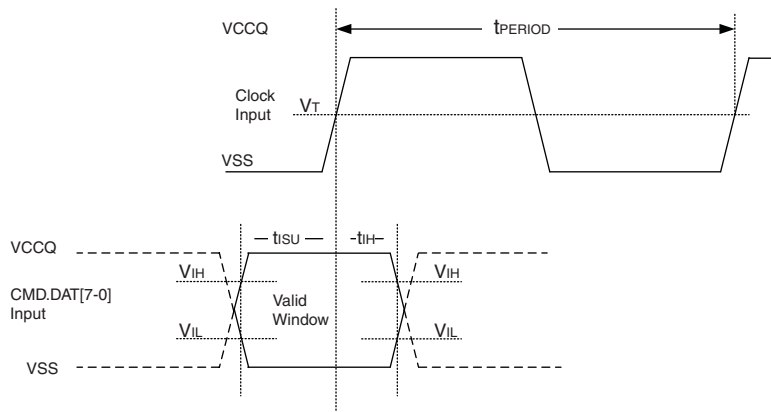

Notes:

1. t_{ISU} and t_{IH} are measured at $V_{IL(max.)}$ and $V_{IH(min.)}$.
2. V_{IH} denotes $V_{IH(min.)}$, and V_{IL} denotes $V_{IL(max.)}$.

Table 7.5 HS200 Device Input Timing

Symbol	Min.	Max.	Unit	Remark
t_{ISU}	1.40	—	ns	$5\text{ pF} \leq \text{CBGA} \leq 12\text{ pF}$
t_{IH}	0.8	—	ns	$5\text{ pF} \leq \text{CBGA} \leq 12\text{ pF}$

7.5.3 HS200 Output Timing

The t_{PH} parameter is defined to allow device output delay to be longer than t_{PERIOD} . t_{PH} may have random phase relation to the clock upon initialization. The Host is ultimately responsible to find the optimal sampling point for the Device outputs, while switching to the HS200 mode.

The impact of a temperature drift (ΔT_{PH}) has to be taken into account when setting the sampling point. Output valid data window (t_{VW}) is available regardless of the drift (ΔT_{PH}) while the position of data window varies by the drift.

Figure 7.5 HS200 Device Output Timing

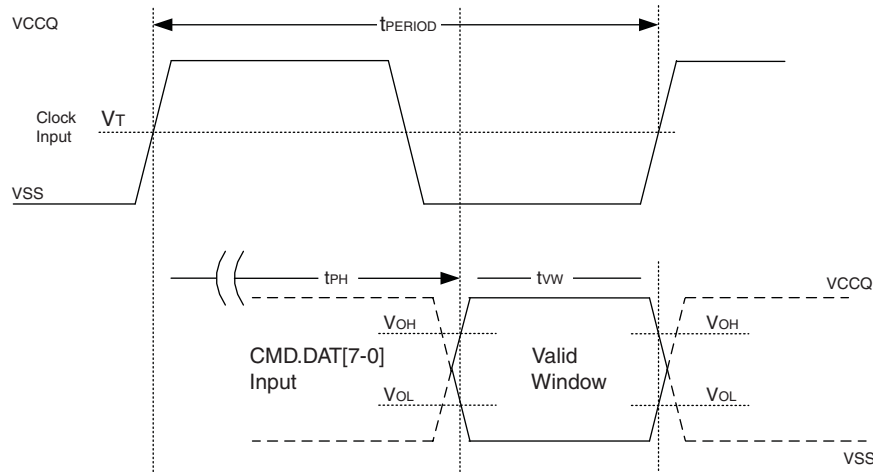

Note:

1. V_{OH} denotes $V_{OH(min)}$, and V_{OL} denotes $V_{OL(max)}$.

Table 7.6 HS200 Device Output Timing

Symbol	Min.	Max.	Unit	Notes
t_{PH}	0	2	UI	Device output momentary phase from CLK input to CMD or DAT lines output. Does not include a long term temperature drift.
ΔT_{PH}	-350 ($\Delta T = -20^{\circ}C$)	+1550 ($\Delta T = 90^{\circ}C$)	ps	Delay variation due to temperature change after tuning. Total allowable shift of output valid window (t_{VW}) from last system Tuning procedure. ΔT_{PH} is 2600 ps for ΔT from $-25^{\circ}C$ to $125^{\circ}C$ during operation.
t_{VW}	0.575	—	UI	$t_{VW} = 2.88$ ns at 200 MHz. Host path may add Signal Integrity induced noise, skews, etc. Expected t_{VW} at Host input is larger than 0.475 UI.

Note:

1. Unit Interval (UI) is one-bit nominal time (i.e. UI = 5 ns at 200 MHz).

Figure 7.6 Δ_{TPH} Consideration



Implementation Guide:

- The host should avoid sampling errors that are caused by the Δ_{TPH} drift.
- Tuning should be performed while the device wakes up after sleep.
- Reducing operating frequency can help overcome the Δ_{TPH} drift.

7.6 Bus Timing Specification in HS400 Mode

7.6.1 HS400 Device Input Timing

The CMD input timing for HS400 mode is the same as CMD input timing for HS200 mode. [Figure 7.7](#) and [Table 7.4](#) show Device input timing.

Figure 7.7 HS400 Device Data Input Timing

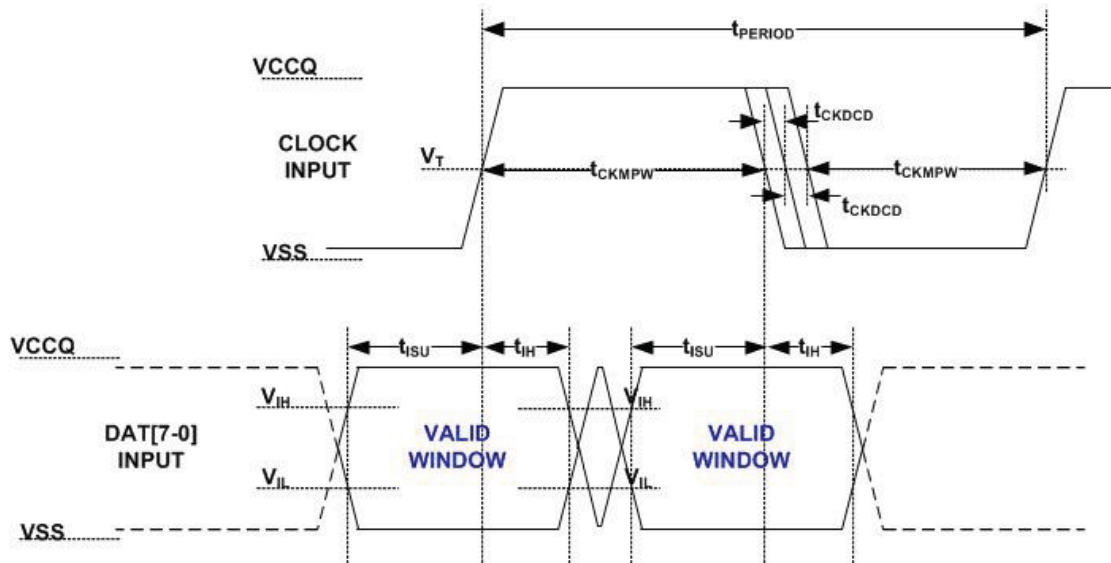

Note:

1. $V_T = 50\%$ of V_{CCQ} indicates clock reference point for timing measurements.

Table 7.7 HS400 Device Input Timing

Parameter	Symbol	Min	Max	Unit	Remark
Input CLK					
Cycle time data transfer mode	t_{PERIOD}	5			200 MHz (max), between rising edges With respect to V_T .
Slew rate	SR	1.125		V/ns	With respect to V_{IH}/V_{IL} .
Duty cycle distortion	t_{CKDCCD}	0.0	0.3	ns	Allowable deviation from an ideal 50% duty cycle. With respect to V_T . Includes jitter, phase noise
Minimum pulse width	t_{CKMPW}	2.2		ns	With respect to V_T .
Input DAT (referenced to CLK)					
Input set-up time	t_{ISUddr}	0.4		ns	$C_{Device} \leq 6$ pF With respect to V_{IH}/V_{IL} .
Input hold time	t_{IHddr}	0.4		ns	$C_{Device} \leq 6$ pF With respect to V_{IH}/V_{IL} .
Slew rate	SR	1.125		V/ns	With respect to V_{IH}/V_{IL} .

7.6.2 HS400 Device Output Timing

The Data Strobe is used to read data in HS400 mode. The Data Strobe is toggled only during data read or CRC status response.

Figure 7.8 HS400 Device Output Timing

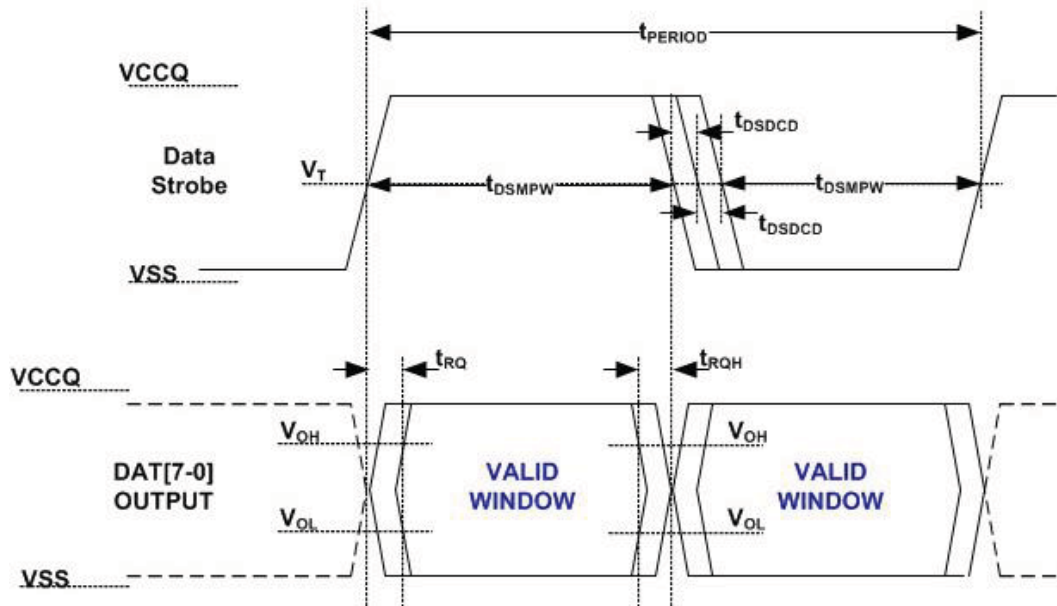

Note:
 $V_T = 50\%$ of V_{CCQ} , indicates clock reference point for timing measurements.

Table 7.8 HS400 Device Output Timing

Parameter	Symbol	Min	Max	Unit	Remark
Data Strobe					
Cycle time data transfer mode	t_{PERIOD}	5			200 MHz (max), between rising edges With respect to V_T
Slew rate	SR	1.125		V/ns	With respect to V_{OH}/V_{OL} and HS400 reference load
Duty cycle distortion	t_{DSDCD}	0.0	0.2	ns	Allowable deviation from the input CLK duty cycle distortion (t_{CKDCD}) With respect to V_T Includes jitter, phase noise
Minimum pulse width	t_{DSMPW}	2.0		ns	With respect to V_T
Read pre-amble	t_{RPRE}	0.4	—	t_{PERIOD}	Max value is specified by manufacturer. Value up to infinite is valid
Read post-amble	t_{RPST}	0.4	—	t_{PERIOD}	Max value is specified by manufacturer. Value up to infinite is valid
Output DAT (referenced to Data Strobe)					
Output skew	t_{RQ}		0.4	ns	With respect to V_{OH}/V_{OL} and HS400 reference load
Output hold skew	t_{RQH}		0.4	ns	With respect to V_{OH}/V_{OL} and HS400 reference load.
Slew rate	SR	1.125		V/ns	With respect to V_{OH}/V_{OL} and HS400 reference load

Table 7.9 HS400 Capacitance and Resistors

Parameter	Symbol	Min	Max	Unit
Pull-up resistance for CMD	R_{CMD}	4.7	100	$k\Omega$
Pull-up resistance for DAT0-7	R_{DAT}	10	100	$k\Omega$
Pull-down resistance for Data Strobe	R_{DS}	10	100	$k\Omega$
Internal pull up resistance DAT1-DAT7	R_{int}	10	150	$k\Omega$
Single Device capacitance	C_{Device}		6	pF

Note:

1. Recommended maximum value is 30 $k\Omega$ for 1.2V and 50 $k\Omega$ for 1.8V interface supply voltages.

7.6.3 HS400 Device Command Output Timing

The Data Strobe is used to response of any command in HS400 mode.

Figure 7.9 HS400 CMD Response Timing

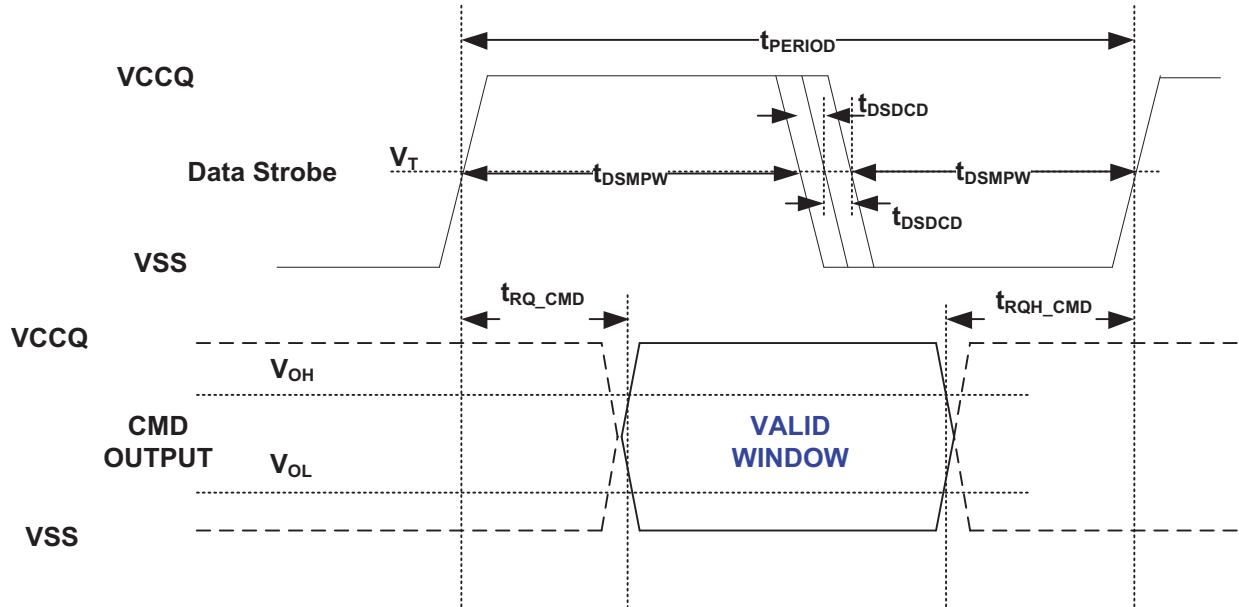

Note:
 $V_T = 50\%$ of V_{CCQ} , indicates clock reference point for timing measurements.

Parameter	Symbol	Min	Max	Unit	Remark
Data Strobe					
Cycle time data transfer mode	t_{PERIOD}	5			200 MHz (max), between rising edges With respect to V_T
Slew rate	SR	1.125		V/ns	With respect to V_{OH}/V_{OL} and HS400 reference load
Duty cycle distortion	t_{DSDCD}	0.0	0.2	ns	Allowable deviation from the input CLK duty cycle distortion (t_{CKDCD}) With respect to V_T Includes jitter, phase noise
Minimum pulse width	t_{DSMPW}	2.0		ns	With respect to V_T
Read pre-amble	t_{RPRE}	0.4	-	t_{PERIOD}	Max value is specified by manufacturer. Value up to infinite is valid
Read post-amble	t_{RPST}	0.4	-	t_{PERIOD}	Max value is specified by manufacturer. Value up to infinite is valid
CMD Response (referenced to Data Strobe)					
Output skew(CMD)	t_{RQ_CMD}		0.4	ns	With respect to V_{OH}/V_{OL} and HS400 reference load
Output hold skew(CMD)	t_{RQH_CMD}		0.4	ns	With respect to V_{OH}/V_{OL} and HS400 reference load
Slew rate	SR	1.125		V/ns	With respect to V_{OH}/V_{OL} and HS400 reference load

7.7 Signal Levels

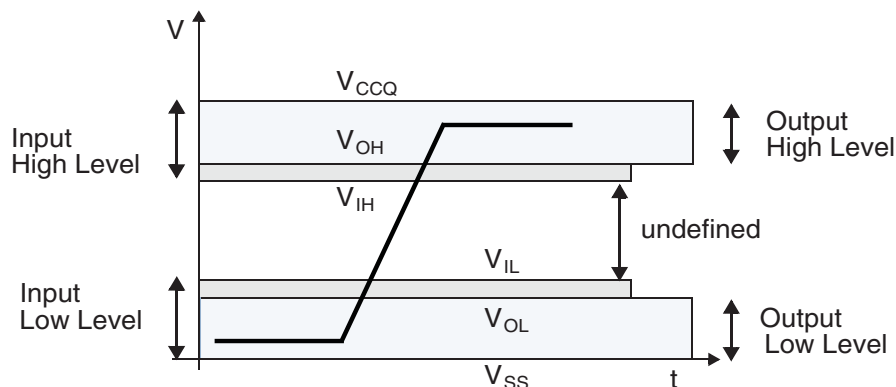
Figure 7.10 Signal Levels

7.8 Open-Drain Mode Bus Signal Level

Table 7.10 Open-Drain Mode Bus Signal Level

Parameter	Symbol	Min.	Max.	Unit	Conditions
Output High Voltage	V_{OH}	$V_{CCQ} - 0.2$		V	$I_{OH} = -100 \mu A$
Output Low Voltage	V_{OL}		0.3	V	$I_{OLL} = 2 \text{ mA}$

7.9 Push-Pull Mode Bus Signal Level — High Voltage e.MMC

Table 7.11 Push-Pull Mode Bus Signal Level — High Voltage e.MMC

Parameter	Symbol	Min.	Max.	Unit	Conditions
Output High Voltage	V_{OH}	$0.75 * V_{CCQ}$		V	$I_{OH} = -100 \mu A$ at V_{CCQ} min
Output Low Voltage	V_{OL}		$0.125 * V_{CCQ}$	V	$I_{OL} = 100 \mu A$ at V_{CCQ} min
Input High Voltage	V_{IH}	$0.625 * V_{CCQ}$	$V_{CCQ} + 0.3$	V	
Input Low Voltage	V_{IL}	$V_{SS} - 0.3$	$0.25 * V_{CCQ}$	V	

7.10 Push-Pull Bus Signal Level — Dual Voltage e.MMC

Table 7.12 Push-Pull Bus Signal Level — Dual Voltage e.MMC

Parameter	Symbol	Min.	Max.	Unit	Conditions
Output High Voltage	V_{OH}	$V_{CCQ} - 0.45V$		V	$I_{OH} = -2 \text{ mA}$
Output Low Voltage	V_{OL}		0.45V	V	$I_{OL} = 2 \text{ mA}$
Input High Voltage	V_{IH}	$0.65 * V_{CCQ}$	$V_{CCQ} + 0.3$	V	
Input Low Voltage	V_{IL}	$V_{SS} - 0.3$	$0.35 * V_{CCQ}$	V	

8. DC Parameter

8.1 Supply Voltage

Table 8.1 Supply Voltage

Symbol	Min.	Max.	Unit
V_{CC}	2.7	3.6	V
V_{CCQ}	1.7	1.95	V
V_{SS}	-0.5	0.5	V

8.2 Bus Operating Condition

Table 8.2 Bus Operating Condition

Parameter	Min.	Max.	Unit
Peak Voltage on all lines	-0.5	$V_{CCQ} + 0.5$	V
Input Leakage Current (after changing the bus width and disconnecting the internal pull-up resistors)	-2	2	μA
Output Leakage Current (after changing the bus width and disconnecting the internal pull-up resistors)	-2	2	μA

9. Ordering Information

The ordering part number is formed by a valid combination of the following:

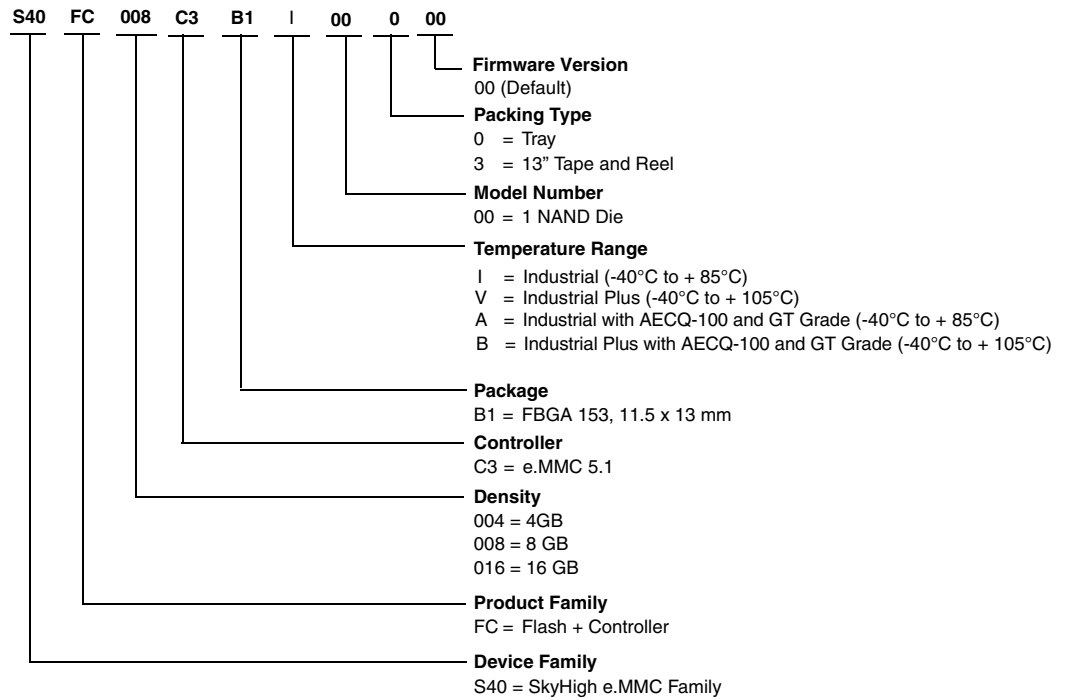

Valid Combinations

Valid Combinations list configurations planned to be supported in volume for this device. Consult your local sales office to confirm availability of specific valid combinations and to check on newly released combinations.

Valid Combinations									
Device Family	Product Family	Density	Controller	Package Type	Temperature Range	Model Number	Packing Type	Firmware Version	Package Description
S40	FC	008	C3	B1	I, V	00	0, 3	00	BGA

10. Physical Diagram

10.1 VFBGA 153 — Package Dimensions 11.5 x 13 x 0.8 mm

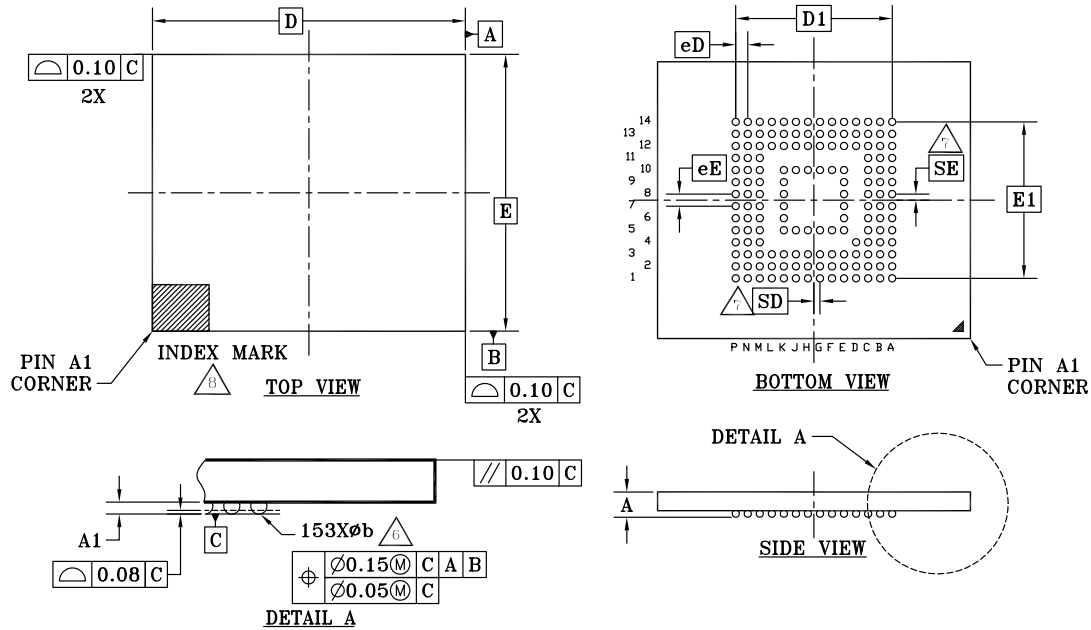

NOTES:

1. DIMENSIONING AND TOLERANCING METHODS PER ASME Y14.5-2009. THIS OUTLINE CONFORMS TO JEP 95, SECTION 4.6.
 2. ALL DIMENSIONS ARE IN MILLIMETERS.
 3. BALL POSITION DESIGNATION PER JEP 95, SECTION 3, SPP-020.
 4. [e] REPRESENTS THE SOLDER BALL GRID PITCH.
 5. SYMBOL "MD" IS THE BALL MATRIX SIZE IN THE "D" DIRECTION. SYMBOL "ME" IS THE BALL MATRIX SIZE IN THE "E" DIRECTION. n IS THE NUMBER OF POPULATED SOLDER BALL POSITIONS FOR MATRIX SIZE MD X ME.
- △ A. DIMENSION "b" IS MEASURED AT THE MAXIMUM BALL DIAMETER IN A PLANE PARALLEL TO DATUM C.
- △ B. [SD] AND [SE] ARE MEASURED WITH RESPECT TO DATUMS A AND B AND DEFINE THE POSITION OF THE CENTER SOLDER BALL IN THE OUTER ROW. WHEN THERE IS AN ODD NUMBER OF SOLDER BALLS IN THE OUTER ROW [D] OR [E] = 0.000. WHEN THERE IS AN EVEN NUMBER OF SOLDER BALLS IN THE OUTER ROW [SD] OR [SE] = e/2
9. TEST PADS MAY BE PRESENT BUT ARE NOT SHOWN. THEY ARE FOR INTERNAL USE ONLY AND ARE NOT SOLDER BALLS.

PACKAGE	TBD 153			NOTE
JEDEC	MO-276			
D X E	13.00mm X 11.50mm PACKAGE			
SYMBOL	MIN.	NOM.	MAX.	
A	0.70	---	0.80	PROFILE
A1	0.17	---	---	BALL HEIGHT
[D]	13.00 BSC			BODY SIZE
[E]	11.50 BSC			BODY SIZE
[D1]	6.50 BSC			MATRIX FOOTPRINT
[E1]	6.50 BSC			MATRIX FOOTPRINT
MD	14			MATRIX SIZE D DIRECTION
ME	14			MATRIX SIZE E DIRECTION
n	153			BALL COUNT
øb	0.25	0.30	0.35	BALL DIAMETER
[eE]	0.50 BSC			BALL PITCH
[eD]	0.50 BSC			BALL PITCH
[SD] / [SE]	0.25 BSC			SOLDER BALL PLACEMENT
	D5-D11, E11-K11, L4-L11, E4-K4 F6-F9, G6-G9, H6-H9, J6-J9			DEPOPULATED SOLDER BALLS

TBD153-0.8/4.16.15