



PRECISION DUAL SAB™ OVER VOLTAGE PROTECTION PCB

GENERAL DESCRIPTION

ALD's SABMBOVP2XX family of Over Voltage Protection Printed Circuit Boards (PCB) are innovative circuits designed to provide precision Over Voltage Protection (OVP) in stacked supercapacitor voltage balancing and other voltage clamping applications. The SABMBOVP2XX circuit can be viewed as a precision voltage clamp circuit that offers a superior zener-diode type of functionality and performs to superior specification and characteristics in creating a strong, precision voltage clamp. Typically, the clamp current changes from a few nA to over 100mA (about 1,000,000 times) at the clamp voltage within a 100mV transition.

The SABMBOVP2XX PCB is populated with an ALD9100XX Supercapacitor Auto Balancing (SAB™) MOSFET IC chip that specifies the circuit threshold or clamping voltage. SAB MOSFETs are ALD exclusive EPAD® MOSFETs designed to address voltage balancing of multiple supercapacitor cells connected in series. SAB MOSFETs and the SABMBOVP2XX boards are designed to be compact, economical and effective in balancing any size supercapacitors with little or no additional power dissipation.

The SABMBOVP is a blank PCB designed to be used with the entire ALD9100XX family of SAB MOSFETs for system designers and application developers. The SABMBOVP contains two OVP circuits, each functioning as a precision voltage clamp with extremely high current gain characteristics. Inside each of two SABMBOVP circuits on the PCB, the internal voltages of the circuit are shifted so that the balancing output current from the SAB MOSFET is amplified to produce nominally 1mA of balancing (clamp) output current at V_{IN} equal to the rated SAB MOSFET threshold voltage.

The SABMBOVP board's two circuits function as a pair of push-pull matched OVP circuits to balance supercapacitors connected in series. Each OVP circuit can also be used individually with any electronic circuitry requiring precision over-voltage clamps. The two OVP circuits offer a very energy efficient solution that can be applied to other low-loss energy harvesting and long-life battery operated applications. They can also be connected in cascade mode, resulting in a single OVP circuit with twice the clamp voltage.

ORDERING INFORMATION

Part Number	Description
SABMBOVP	Blank Universal PCB ready for one ALD9100XX Dual SAB MOSFET IC
SABMBOVP2XX	SABMBOVP Board with one installed ALD9100XXSALI
Example: SABMBOVP225	SABMBOVP Board with one installed ALD910025SALI

Note: SABMBOVP2XX is optional with specific ALD9100XXSALI units installed. XX = 16, 17, 18, 19, 20, 21, 22, 23, 24, 25, 26, 27, 28, 29, 30.
See page 6 for full listing of part numbers.

FEATURES & BENEFITS

- Extremely low output currents at input voltages below the threshold voltage
- Precision threshold voltage set point
- Extreme change of output current in response to small changes in input voltage, i.e. $dI/dV = \sim 3mA/1mV$
- High maximum clamp output current of 100 mA or greater
- Over Voltage Protection for any size of supercapacitor stacks in series or in parallel
- Ultra-low power for energy harvesting and battery-powered applications
- Fully automatic OVP - no trimming adjustments, no additional circuits and no software
- Broad selection of threshold voltages for wide variety of OVP applications
- Corrects imbalances in both capacitance value and DC leakage current

MECHANICAL DRAWING

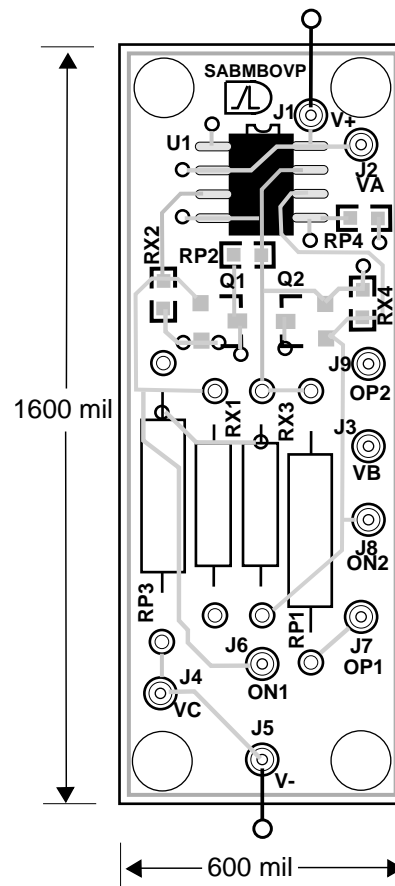

* Magnified, not to scale

PRECISION OVP VOLTAGE CLAMPING EXAMPLE

The SABMBOVP PCB is typically populated with one ALD SAB™ MOSFET IC chip selected to establish the threshold or clamping voltage of the circuit. The ALD910025 chip, for example, provides a threshold voltage of 2.50V, which allows the OVP circuit to behave similar to a pair of super precision zener diodes stacked in series, each clamping the output at 2.5V. The following scenario illustrates the relative magnitude of input voltage vs. output current change:

The SABMBOVP PCB balances a pair of series-connected supercapacitor cells by featuring two near identical over-voltage clamp circuits, one for parallel connection to each cell. Each board has two output channels with each having a nominal threshold setting of 2.5V. At 2.5V input voltage (V_{IN}), the nominal output current (I_{OUT}) is typically 1.0mA. At V_{IN} voltages less than 2.5V, I_{OUT} decreases rapidly. Hence, at $V_{IN} = \sim 2.40V$ I_{OUT} is equal to 0.07 μA , and at $V_{IN} = 2.30V$, I_{OUT} drops to 0.01 μA . At any V_{IN} less than 2.40V, there is essentially no SABMBOVP power dissipation or any energy draw from the supercapacitors.

At V_{IN} above the 2.5V threshold level, I_{OUT} increases sharply and steeply, to near vertical. It features high gain dI/dV at small incremental voltages of V_{IN} greater than 2.5V. At V_{IN} of 2.53V, for instance, the output current (I_{OUT}) is typically about 100mA, 1,400,000 times higher than I_{OUT} at V_{IN} at 2.4V. This high current level (avalanche effect) change tends to limit the V_{IN} to rise very slowly and clamps the V_{IN} to 2.53V. The standard SABMBOVP225 board is designed to limit I_{OUT} to approximately 100mA at V_{IN} voltages above 2.53V. If the user needs to increase this clamp current, then an external resistor can be parallel connected across each of R_{P1} and R_{P3} . An external 24 Ω 1W resistor connected across each R_{P1}/R_{P3} resistor would increase the max. clamp output current to 200mA.

For a pair of 2.7V rated supercapacitors connected in series, the SABMBOVP225 functions to limit each supercapacitor to about 2.53V maximum V_{IN} voltage. Accordingly, when two supercapacitor cells are connected to the SABMBOVP225 PCB and are not balanced in either their capacitance values and/or leakage currents, the cell with the higher voltage tends to be limited in V_{IN} rise by the corresponding SABMBOVP225 circuit with up to 100mA bypass current. A 5.00V power supply connected across two supercapacitor cells in series would limit one cell to a maximum of 2.53V leaving the other cell at 2.47V (5.00V - 2.53V). If a cell voltage initially exceeds 2.53V, it rapidly discharges and its cell voltage is clamped at 2.53V while the other cell voltage remains at 2.47V.

In this example, supercapacitors should be normally set and operated at 2.40V for optimal operation without energy loss. If the desired normal operating voltage is 2.5V instead, then perhaps a SABMBOVP226 should be selected instead.

PLUG-AND-PLAY BALANCING SOLUTION

The SABMBOVP2XX is a simple, out-of-the-box plug-and-play PCB solution for development, prototyping, demonstration and evaluation, or production deployment. It is suited for balancing supercapacitor stacks ranging from two in series to hundreds in series, and for supercapacitor capacitance values ranging from 0.1F to 3000F and beyond. Although the current dissipation of the

SABMBOVP2XX is higher at the threshold voltage due to an active current amplifier on board, it is still far below any other means of correcting for capacitance imbalances. At input voltages of about 0.1V below the threshold voltage, the average additional power dissipation due to use of SABMBOVP2XX boards is zero, which makes this method of supercapacitor balancing very energy efficient. It is especially suited for low loss energy harvesting and long life battery operated applications.

The SABMBOVP2XX circuit features a sharp and high gain current amplifier, which produces greater than 1,000,000 times output current increase with small increments of less than 100 mV input voltage change.

Supercapacitors, also known as ultracapacitors, when connected two cells in series can be balanced with a single SABMBOVP2XX PCB. Supercapacitors, when connected more than two cells in series, can be balanced with more than one SABMBOVP2XX board (each with ALD9100XX packages installed).

The ALD9100XX SAB MOSFET family offers the user a selection of different threshold voltages for various supercapacitor nominal operating voltage values and desired leakage balancing characteristics. Each SAB MOSFET generally requires connecting its V+ pin to the most positive voltage and its V- and IC pins to the most negative voltage within the package. Note that each Drain pin has an internal reverse biased diode to its Source pin, and each Gate pin has an internal reverse biased diode to V-. All other pins must have voltages within V+ and V- voltage limits within the same packaged unit.

Standard ESD protection facilities and handling procedures for static sensitive devices must also be used while installing the ALD9100XX units. Once installed, the connection configuration will protect the ALD9100XX units from ESD damage. When connected to a supercapacitor stack, the ALD9100XX is further protected from virtually any ESD damage due to the large capacitance of the supercapacitors, which sinks any ESD charge and thereby reduces any of the terminal voltages to minimal harmless values.

SABMBOVP2XX PRINTED CIRCUIT BOARDS

Additional features include:

- 1) ALD9100XX Dual SAB MOSFET with other required components installed and tested.
- 2) Optional reverse biased external clamping power diodes (schottky rectifiers) can be installed by user.
- 3) Multiple SABMBOVP2XX PCBs can be cascaded to form a series chain, paralleling a series-connected chain of supercapacitors.
- 4) Compact size of 0.6 in by 1.6 in with mounting holes.
- 5) Rated for RoHS compatible/industrial temperature range of -40°C to +85°C.

The SABMBOVP Printed Circuit Board is available as a blank PCB board, made with RoHS compliant FR4 material, ready for mounting a single ALD9100XX 8-lead SOIC unit. SABMBOVP2XX PCB are SABMBOVP with an ALD9100XX chip and other components factory-installed and tested. ALD9100XX are supplied with a 2-digit suffix, which denotes the specific ALD9100XX component

mounted and tested on the PCB. All that is required of the user is to mount the PCB and wire the appropriate connections from the SABMBOVP2XX board to the respective supercapacitor nodes.

Each SABMBOVP2XX Printed Circuit Board has three key terminal connections, V_A (VA), V_B and V_C (VC). V_A is directly connected to terminal A, which must be connected to the most positive voltage for the individual SABMBOVP2XX board. V_C is the most negative voltage present for the same SABMBOVP2XX board. Any number of SABMBOVP2XX boards can be daisy-chain connected in series. For example, three SABMBOVP2XX boards, each with an ALD9100XSALI installed, can be connected in series to a +15V power supply, provided care is taken to insure that each SABMBOVP2XX PCB V_A is connected to the V_A of the next SABMBOVP2XX PCB in series.

For example, an SABMBOVP225 would have typical internal voltages from V_A to V_C of +5.0V. Each individual ALD910025SALI IC chip on the board has a +15.0V max. rating, but each chip generally experiences only about +5.0V. Three SABMBOVP2XX PCB connected in series has a total max. voltage rating of +45V (+15V x 3), well beyond the +15V power supply.

The ALD9100XX is rated for reverse bias diode currents of up to 80mA maximum for each SAB MOSFET on board. Any reverse bias condition as a result of changing supercapacitor voltages, especially during fast supercapacitor discharge, could lead to some internal nodes temporarily reverse biased with surge current in excess of this limit. The SABMBOVP2XX board has additional optional TO-277 footprints for mounting external schottky rectifiers (power diodes) to clamp such surge current transients. The user is advised to determine the various power and current limits, including temperature and heat dissipation considerations, when selecting a suitable component for such purpose. The appropriate level of derating and margin allowance must also be added to assure long-term reliability of the PCB.

SUPERCAPACITORS

Supercapacitors are typically rated with a nominal recommended working voltage established for long life at their maximum rated operating temperature. Excessive supercapacitor voltages that exceed the supercapacitor's rated voltage for a prolonged time period will result in reduced operating life and eventual rupture and catastrophic failure. To prevent such an occurrence, a means of automatically adjusting (charge-balancing) and monitoring the maximum voltage is required in most applications having two or more supercapacitors connected in series, due to the different internal leakage currents that vary from one supercapacitor to another.

Each supercapacitor cell has a tolerance difference in capacitance, internal resistance and leakage current. When connected in series, these differences create imbalance in cell voltages, which must be balanced so that any individual cell voltage does not exceed its rated max. voltage. Initially, cell voltage imbalance is caused by capacitance value differences. Supercapacitors selected from the same manufacturer make and model batch can be measured and matched to deliver reasonable initial cell voltages.

However, even with selection for matching, supercapacitor capacitance value mismatches can still cause significant initial cell voltage imbalance that necessitates extra voltage margin allowances. When capacitance values of supercapacitors become larger, for values ranging from 100F to 1000F, this mismatch problem become more pronounced and also become much more difficult to correct. A small MOSFET current meant for correcting leakage current imbalances may not adequately do the job to balance supercapacitor cell voltages quickly enough to avoid prolonged voltage imbalances. Hence if the capacitance values of supercapacitors cause the initial voltage imbalance, this imbalance can remain for a long time, even though there is a small balancing current at work. Hence there is a need to amplify this balancing current to much higher levels at the critical threshold point, while still preserving the merits and distinctive performance features and benefits of SAB MOSFET balancing.

Next, cell voltage imbalance due to individual cell leakage currents must be compensated.

The supercapacitor leakage current itself is a variable function of its many parameters such as aging, initial leakage current at zero input voltage, the material/construction of the supercapacitor, and the operating bias voltage. Its leakage is also a function of the charging voltage, the charging current, operating temperature range and the rate of change of many of these parameters. Supercapacitor balancing must accommodate these changing conditions.

By using the appropriate ALD SAB MOSFET and the appropriate SABMBOVP2XX board, users can compensate for all of these causes of imbalance and automatically balance supercapacitor imbalances including capacitance value mismatches and leakage current mismatches.

ENERGY HARVESTING APPLICATIONS

Supercapacitors offer an important benefit for energy harvesting applications using a low energy source, by buffering and storing such energy to drive a higher power load.

For energy harvesting applications, supercapacitor leakage currents are a critical factor, as the average energy harvesting input charge must exceed the average supercapacitor internal leakage currents in order for any net energy to be harvested and saved. Often, the input energy is variable, meaning that its input voltage and current magnitude are not constant and may be dependent upon a whole set of other parameters such as the source energy availability, energy sensor conversion efficiency, changing environmental conditions, etc.

SAB MOSFETs used for charge balancing, due to their high input threshold voltages, are completely turned off initially, consuming zero drain current while the supercapacitor is being charged, maximizing any energy harvesting gathering efforts. The SAB MOSFET does not become active until the supercapacitor is already charged to over 90% of its max. rated voltage. The trickle charging of supercapacitors with energy harvesting techniques tends to work well with SAB MOSFETs as charge balancing devices, as it is less likely to have high transient energy spurts resulting in excessive voltage or current excursions.

If an energy harvesting source only provides a few μA of current, the power budget does not allow wasting any of this current on capacitor leakage currents and power dissipation of resistor or operational amplifier based charge-balancing circuits. It may also be important to reduce long term leakage currents, as energy harvesting charging at low levels may take up to many days.

In summary, in order for an energy harvesting application to be successful, the input energy harvested must exceed all the energy required, due to the leakages of the supercapacitors and the charge-balancing circuits, plus any load requirements. With their unique autobalancing characteristics and near-zero charge loss, SAB MOSFETs are ideal devices for use in supercapacitor charge-balancing in energy harvesting applications.

BATTERY POWERED APPLICATIONS

Many battery powered circuits requiring a supercapacitor to boost power output can benefit from using SAB MOSFETs for supercapacitor balancing. The additional power burn by using SAB MOSFETs for supercapacitor stack balancing can actually be negative, as adding SAB MOSFETs can save supercapacitor leakage current and associated power dissipation by lowering the operating bias voltage of the leakier supercapacitor. Applications that depend on long life battery usage must take into account the supercapacitor leakage current and balancing circuit power burn because the currents involved are steady state DC currents that are continuous throughout the lifetime of the application circuit and its battery life. The average added power dissipation with the addition of the SABMBOVP2XX board is zero, provided the selection of the operating voltages and SAB MOSFETs are appropriate for the leakage currents of the supercapacitors specified.

CONNECTION TO OTHER SABMBXX OR SABMBOVP2XX PCBs

The SABMBOVP2XX is compatible with other SABMBXX or SABMBOVP2XX boards and is designed to be used along with these other boards connected in series to achieve balancing the corresponding number of supercapacitors installed in a stack. For example, six supercapacitors in series can be balanced with three SABMBOVP2XX PCB connected in series.

For more information on the CHARACTERISTICS OF SUPERCAPACITOR AUTO BALANCING (SAB™) MOSFETS, please refer to the following documents:

- * ALD8100XX/ALD9100XX FAMILY of SUPERCAPACITOR AUTO BALANCING (SAB™) MOSFET ARRAYS
- * Individual datasheet for chosen SAB MOSFET.

CAUTION:

Users must limit the voltage across any ALD9100XX chip to 15.0V max.

SABMBOVP PCB CONNECTION TO SUPERCAPACITORS

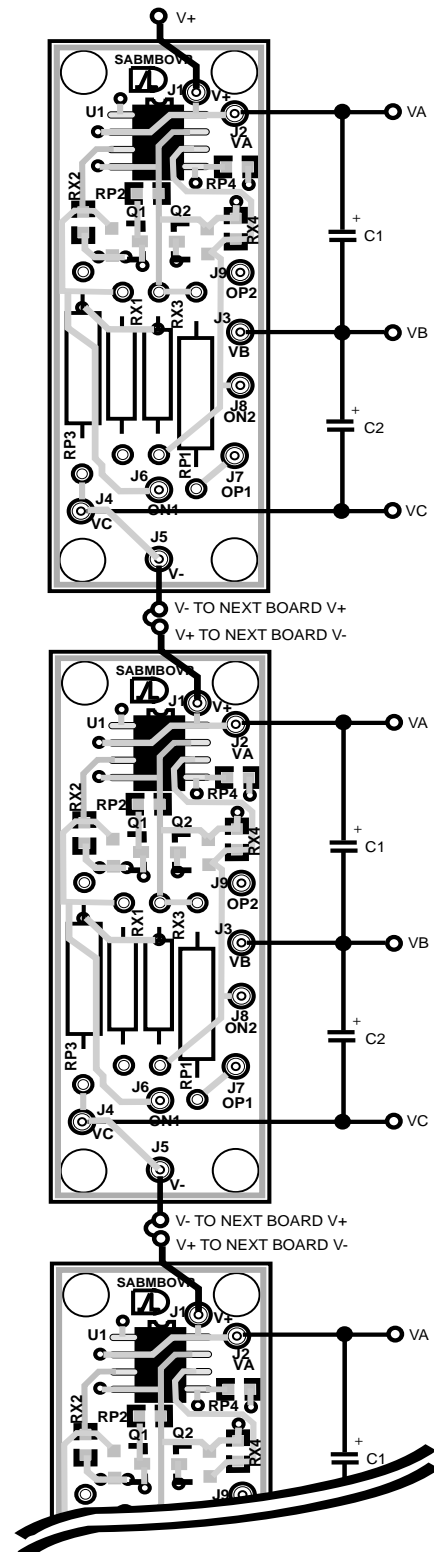

* Magnified, not to scale

TYPICAL PERFORMANCE CHARACTERISTICS

