

This document is the property of Amphenol Corporation and is delivered on the express condition that it is not to be disclosed, reproduced or used, in whole or in part, for manufacture or sale by anyone other than Amphenol Corporation without its prior consent, & that no right is granted to disclose or to use any information in this document.

Customer Drawing

| REVISIONS | | | | |
|-----------|--------|--|---------|------------|
| SYM | ECN | DESCRIPTION | DATE | APPROVED |
| B | HK3854 | RELEASE TO PRODUCTION | 5/18/06 | Michael.IP |
| C | HK4281 | CHANGE THE TOLERANCE TO MEET SATA SPEC | 1/29/07 | Michael.IP |

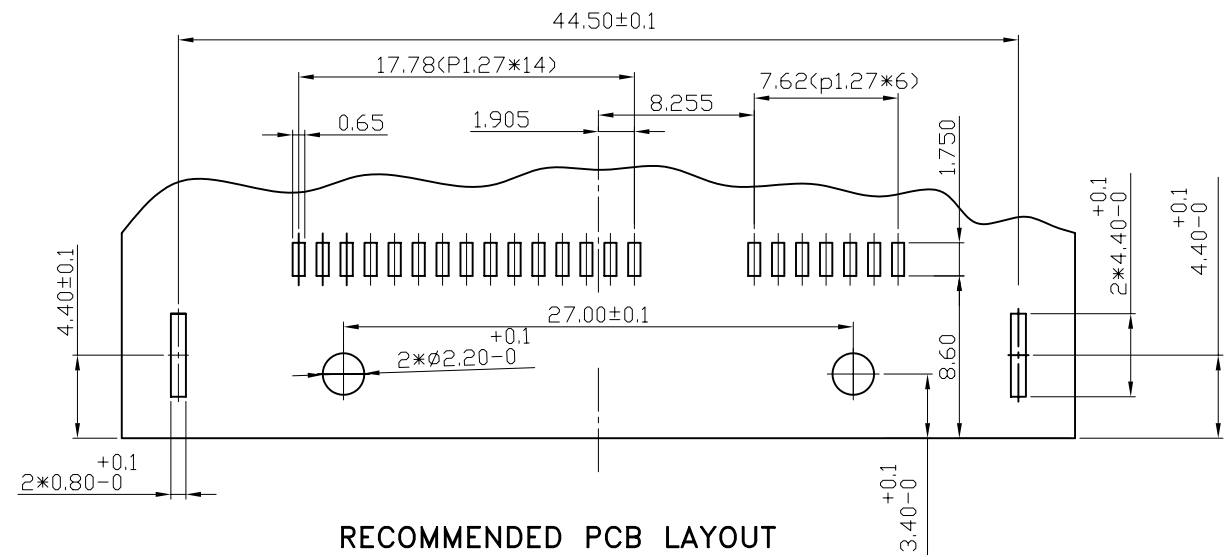
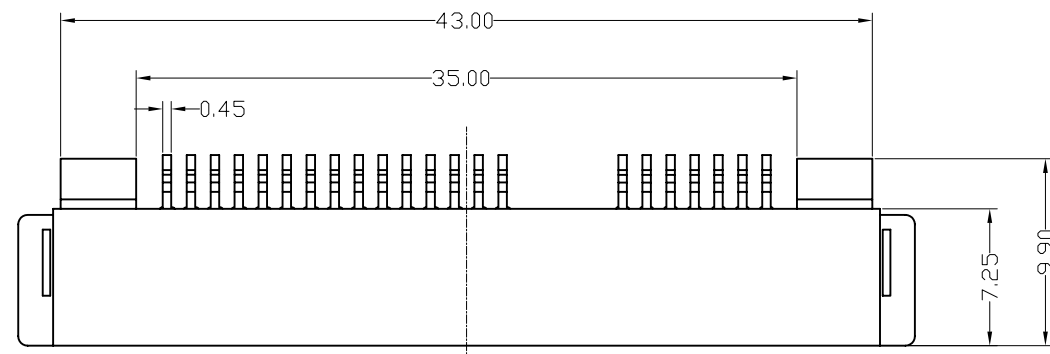

RECOMMENDED PCB LAYOUT
(PC BOARD THICKNESS: 1.60mm±0.10)

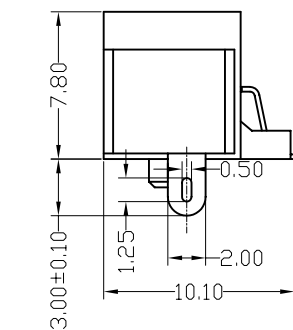
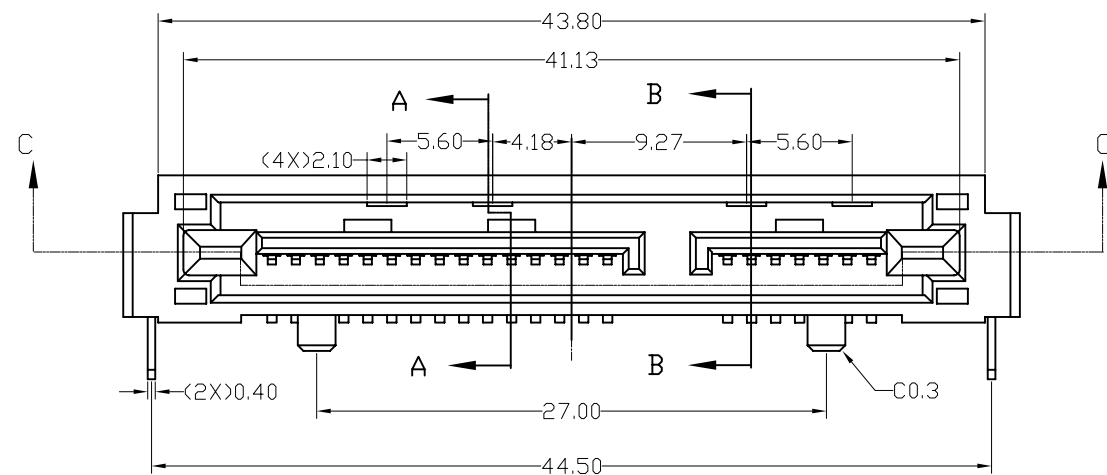

NOTE:

- MATERIAL:**
 HOUSING: HIGH TEMPERATURE THERMOPLASTIC MATERIAL , UL 94 V-0, BLACK;
 CONTACTS: COPPER ALLOY T=0.25mm;
 CONTACT FINISHED: 1.30-2.54um. NICKEL UNDER PLATED ON ENTIRE CONTACT;
 SEE NOTES 4 FOR GOLD PLATING ON MATING AREA;
 2.54-5.08um MATTE TIN PLATED ON TAIL AREA;
 SOLDER TAB: BRASS, t=0.4±0.05mm;
 SOLDER TAB FINISHED: 2.54-5.08um PURE MATTE TIN OVER 1.30um MIN. NICKEL;
- SPECIFICATIONS:**
 RATED CURRENT: SIGNAL PIN 1.5A MIN
 POWER PIN 1.5A MIN
 DIELECTRIC STRENGTH: 500V FOR 1 MINUTE
 INSULATION RESISTANCE: 1x10³ MΩ
 TEMPERATURE: -40°C TO +105°C
 CONTACT RESISTANCE: 30mΩ MAX
- PACKAGE:** PACKING WITH TRAY.
- ORDERING INFORMATION:**

SATA - 001 - 0225 - X

- GOLD PLATING ON MATING AREA:
 1: 0.76 um MIN.
 2: 0.38 um MIN.
 3: GOLD FLASH

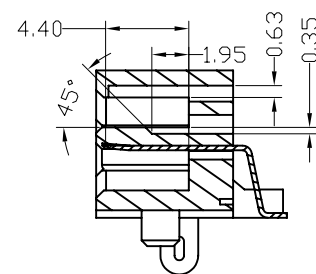
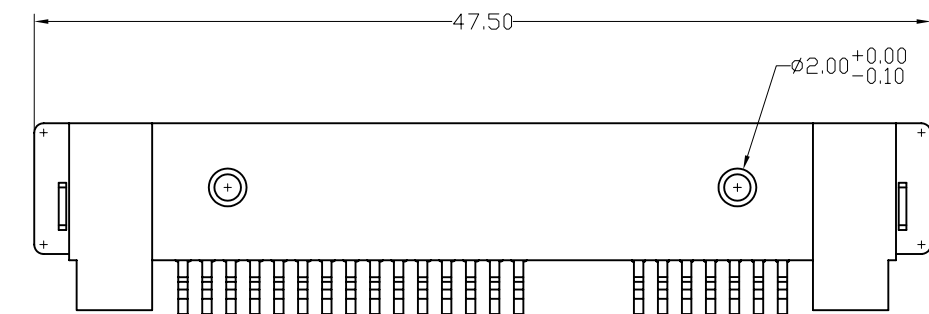

SECTION A-A

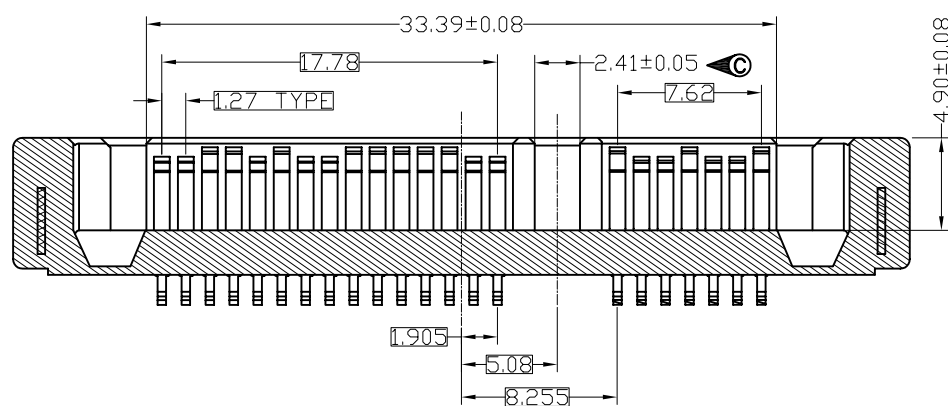

SECTION C-C

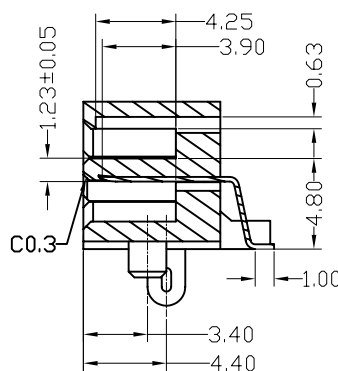

SECTION B-B

| | | | | | |
|---------------------------------------|---------|------------------------------------|---------|---|--|
| UNLESS OTHERWISE SPECIFIED TOLERANCES | | APPROVAL | DATE | Amphenol | |
| .X | +/- | DRAWN: Maya.Lu | 1/29/07 | | |
| .XX | +/- | CHECKED: Micheal.IP | 1/29/07 | TITLE 15+7PIN SATA PLUG,SMT TYPE | |
| .XXX | +/- | CHECKED | | | |
| FRACTIONS | +/- | DRAWING FILE : | | SIZE DRAWING NO. REV. A3 C SATA-001-0225-X C | |
| ANGLES | +/- | \DRAWING\SATA\C SATA0010225X-C.DWG | | | |
| FOR MATERIALS AND FINISHES SEE NOTES | | ANGLE OF PROJECTION | | SCALE NONE SHEET 1 OF 1 | |
| REMOVE SHARP EDGES | | | | | |
| DIMENSIONS | | | | | |
| — U.S. — | INCHES— | | | | |
| (METRIC) | (MM) | | | | |