

Breakout board embedding the VL53L4CD Time-of-Flight high-accuracy proximity sensor



Features

- VL53L4CD Time-of-Flight high-accuracy proximity sensor
- True distance measurement independent of the target size and reflectance
- Divisible board that can be used as a mini-PCB breakout board, easy to integrate into the customer's device
- Two breakout boards available in the package

Description

The SATEL-VL53L4CD package includes two breakout boards, which can be easily integrated into the customer's devices.

The PCB section that embeds the VL53L4CD module is perforated. The developers can then break off the mini-PCB and use it in a 3.3 V supply application via flying wires.

This makes it easier to integrate the SATEL-VL53L4CD breakout boards into the development and evaluation devices thanks to their small size.

Product summary	
Breakout board embedding the VL53L4CD Time-of-Flight high-accuracy proximity sensor	SATEL-VL53L4CD
Time-of-Flight high-accuracy proximity sensor expansion board based on the VL53L4CD for STM32 Nucleo	X-NUCLEO-53L4A1
Time-of-Flight high-accuracy proximity sensor	VL53L4CD
Applications	Personal Electronics - Audio and Video Gaming and Drones Virtual - Augmented Reality Wearable

1 Breakout boards

You can break the breakout boards along the perforations to use the mini-PCB.

Figure 1. Breakout board

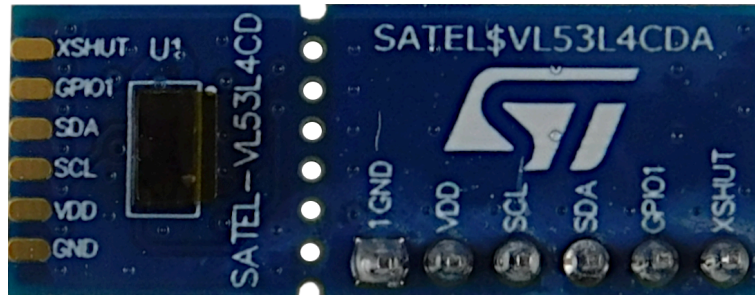

This setup is easier to integrate into a customer's device thanks to its small form factor.

You can plug the VL53L4CD breakout boards directly onto the X-NUCLEO-53L4A1 expansion board through two six-pin connectors (Figure 2), or connect them to the board through flying wires (Figure 3).

Figure 2. SATEL-VL53L4CD breakout boards connected to the X-NUCLEO-53L4A1 expansion board

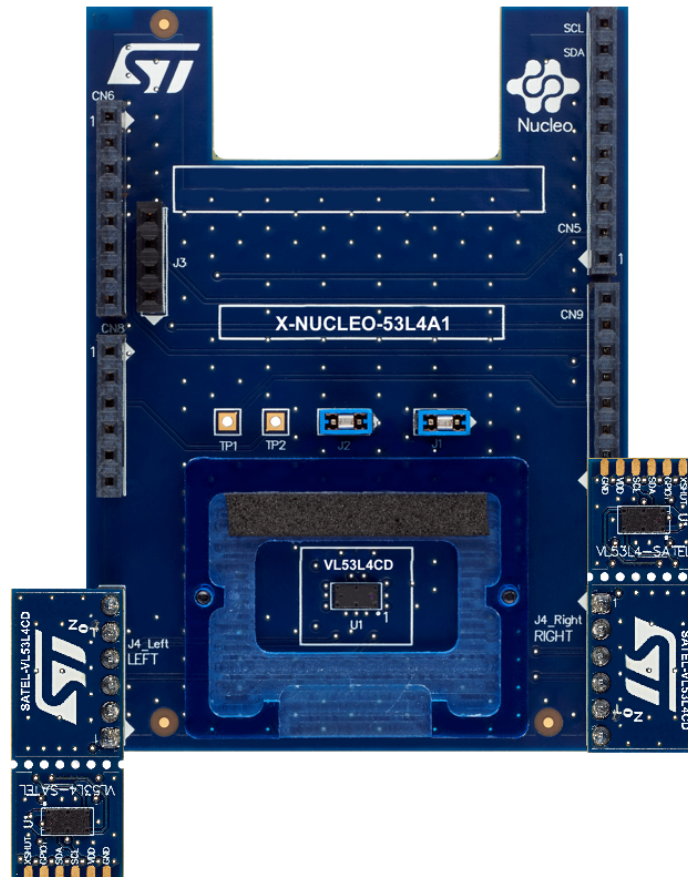
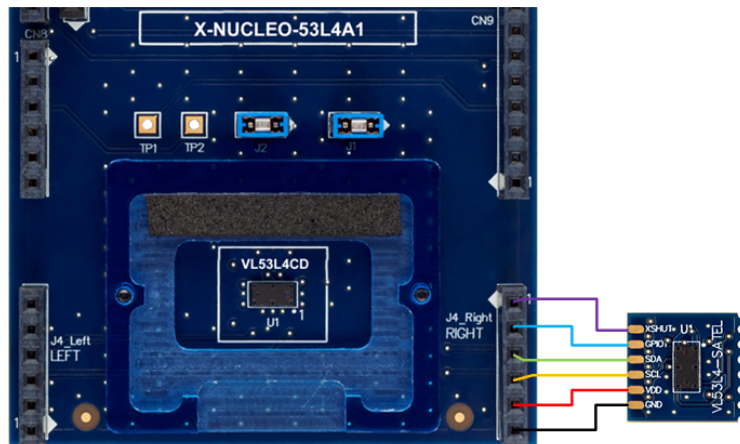
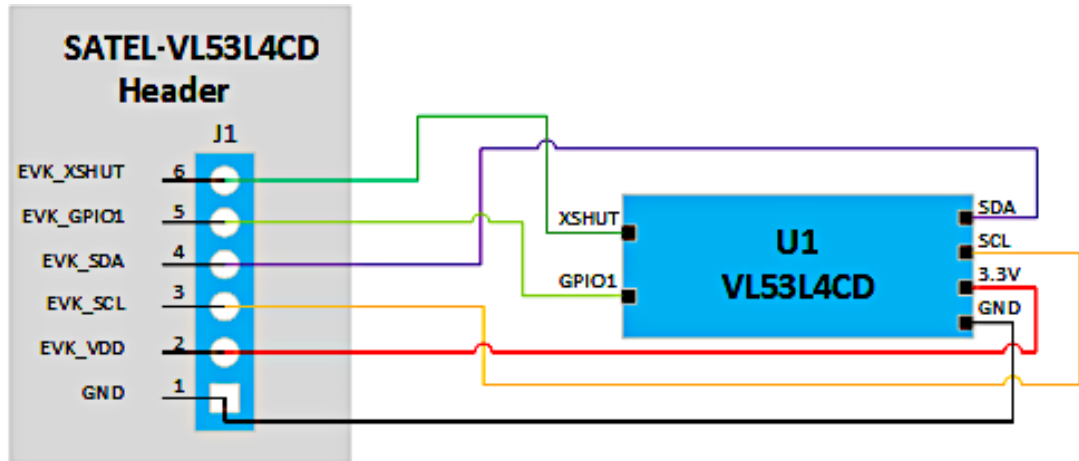

Figure 3. SATEL-VL53L4CD mini-PCB flying wire connection to the X-NUCLEO-53L4A1 expansion board



2 Simplified schematic

Figure 4. SATEL-53L4CD simplified schematic



3 Schematic diagrams

Figure 5. SATEL-VL53L4CD circuit schematic

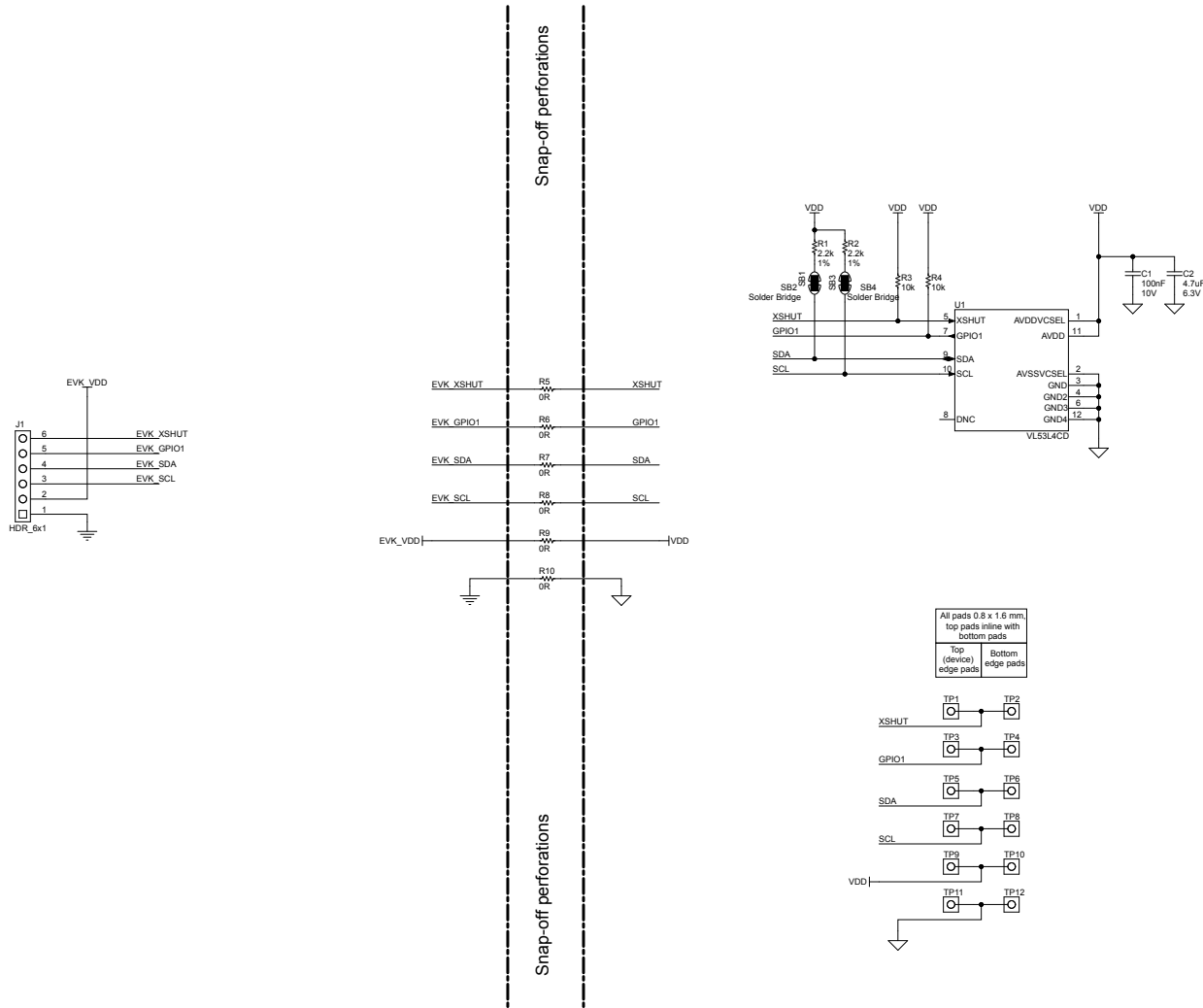

4 Board versions

Table 1. SATEL-53L4CD versions

Finished good	Schematic diagrams	Bill of materials
SATEL\$VL53L4CDA ⁽¹⁾	SATEL\$VL53L4CDA schematic diagrams	SATEL\$VL53L4CDA bill of materials

1. This code identifies the SATEL-VL53L4CD expansion board first version.

Revision history

Table 2. Document revision history

Date	Revision	Changes
24-Jan-2022	1	Initial release.