

Product Overview

The SBB1089Z is a high performance InGaP HBT MMIC amplifier utilizing a Darlington configuration with an active bias network. The active bias network provides stable current over temperature and process Beta variations. Designed to run directly from a 5V supply, the SBB1089Z does not require a dropping resistor as compared to typical Darlington amplifiers. The SBB1089Z product is designed for high linearity 5V gain block applications that require small size and minimal external components. It is internally matched to 50Ω.



3-pin SOT-89 Package

Key Features

- 50MHz – 850MHz Operational Frequency
- OIP3 = +43.1dBm at 240MHz
- P1dB = +19.6dBm at 500MHz
- Single Fixed 5V Supply
- Robust 1000V ESD, Class 1C
- Patented Thermal Design and Bias Circuit
- Low Thermal Resistance

Functional Block Diagram

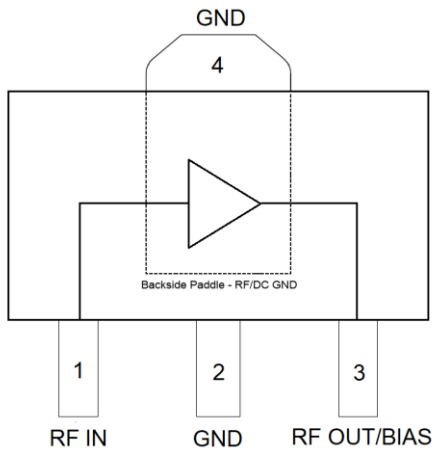

Top View

Applications

- Receiver IF Amplifier
- Cellular, PCS, GSM, UMTS
- Wireless Data, Satellite Terminals

Ordering Information

Part No.	Description
SBB1089Z	7" Reel with 1000 pieces
SBB1089ZPCK1	50MHz to 850MHz PCBA with 5-piece sample bag

Absolute Maximum Ratings

Parameter	Rating
Storage Temperature	-55 to 150 °C
RF Input Power, CW, 50 Ω, T=+25 °C	+24 dBm
Device Voltage (V _{CC})	+5.5 V
Device Current (I _{CC})	110 mA
Power Dissipation	0.61 W
Junction Temperature (T _J)	+150 °C

Exceeding any one or a combination of the Absolute Maximum Rating conditions may cause permanent damage to the device.

Recommended Operating Conditions

Parameter	Min	Typ	Max	Units
Device Voltage (V _{CC})		+5	+5.3	V
T _{CASE}	-55		+105	°C

Electrical specifications are measured at specified test conditions. Specifications are not guaranteed over all recommended operating conditions. Application of conditions to the device outside the Recommended Operating Conditions may reduce device reliability and performance.

Electrical Specifications

Parameter	Conditions ⁽¹⁾	Min	Typ	Max	Units
Operational Frequency Range		50		850	MHz
Gain	70MHz		15.5		dB
	240MHz	14	15.5	17	dB
	400MHz	14	15.5	17	dB
Input Return Loss	70MHz to 5000MHz	14	18		dB
Output Return Loss	70MHz to 5000MHz	12	16		dB
Output P1dB	70MHz		+19		dBm
	240MHz		+19		dBm
	400MHz	+18	+19		dBm
Output IP3	P _{out} = 0 dBm/tone, Δf = 1 MHz, Center Freq.= 70MHz		+42		dBm
	P _{out} = 0 dBm/tone, Δf = 1 MHz, Center Freq.= 240MHz		+43		dBm
	P _{out} = 0 dBm/tone, Δf = 1 MHz, Center Freq.= 400MHz	+38.5	+40.5		dBm
Noise Figure	500MHz		3.5	4.2	dB
Reverse Isolation	70MHz to 5000MHz		18		dB
Device Operating Current		82	90	98	mA
Thermal Resistance, θ _{JC}	Junction to case		48.8		°C/W

Notes:

1. Test conditions unless otherwise noted: V_{CC} = +5.0 V, I_{CC} = 90mA, Temp= +25 °C, 50 Ω system.

Evaluation Board

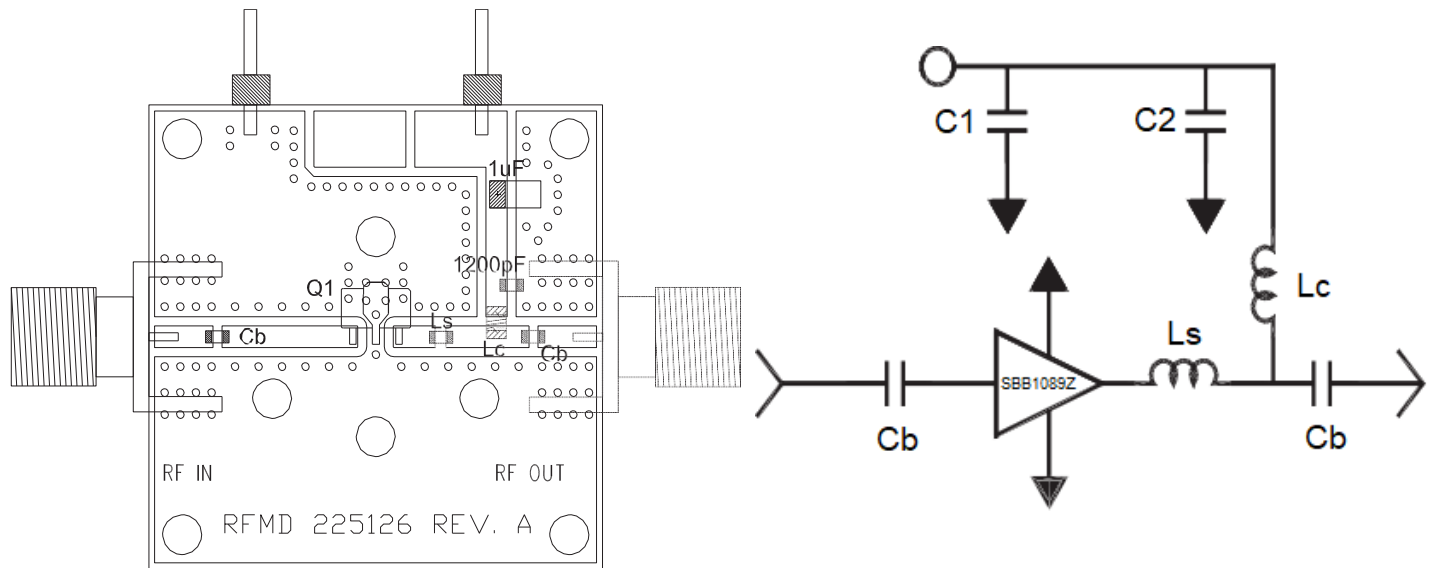

Bill of Material

Reference Des.	Value	Description	Manuf.	Part Number
n/a	n/a	Printed Circuit Board	Qorvo	
Q1	n/a	Cascadable Amplifier	Qorvo	SBB1089Z
Cb	8200 pF	CAP, 0603, 10%, 50V, X7R	various	
C1	1 uF	CAP, 1206, 20%, 20V, TANT-A	various	
C2	1200 pF	CAP, 0603, 10%, 50V, X7R	various	
Ls	2.7 nH	IND, 0603, +/-0.3nH	Murata	LL1608-FSL2N7S
Lc	1.2 uH	IND, 1008, 5%	Coilcraft	1008LS-122XJLC

Typical Performance

Test conditions unless otherwise noted: $V_{CC} = +5.0V$, $I_{CC} = 90mA$, $Temp = +25^{\circ}C$, 50Ω system.

Parameter	Typical Value							Units
Frequency	50	70	100	240	400	500	850	MHz
Gain	16	15.5	15.5	15.5	15.5	15.5	15.5	dB
Input Return Loss	13	16	17	19	19	19	18	dB
Output Return Loss	18	20	21	23	24	23	17	dB
Reverse Isolation	18	18	18	18	18	18	18	dB
Output P1dB	+19	+19	+19	+19	+19	+19	+18	dBm
OIP3 ⁽¹⁾	+41.5	+42	+43	+43	+41	+40	+35	dBm
Noise Figure	3.5	3.3	3.2	3.1	3.2	3.2	3.4	dB

Notes:

1. $P_{out} = 0$ dBm/tone, $\Delta f = 1$ MHz

Performance Plots

Test conditions unless otherwise noted: $V_{CC} = +5.0V$, $I_{CC} = 90mA$, $Temp = +25^{\circ}C$, 50Ω system.

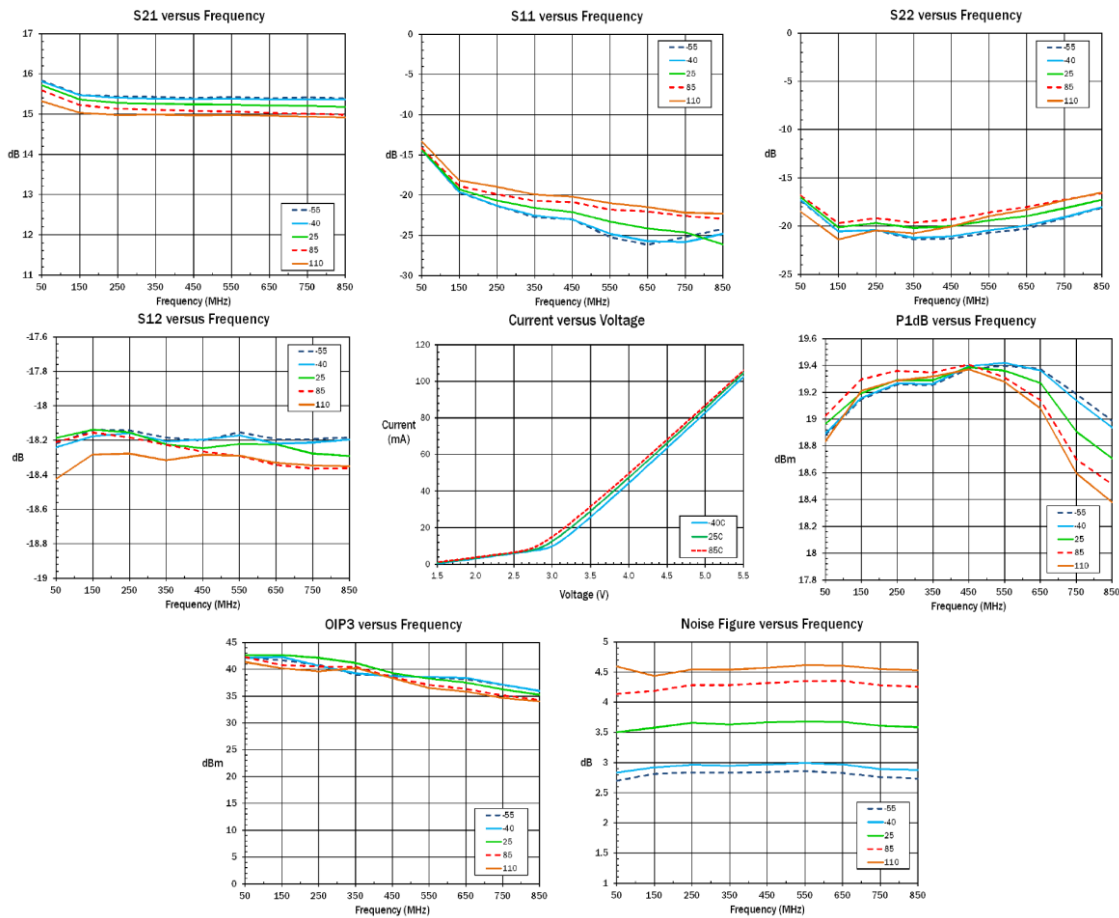

Performance Plots – with BIAS Tees

Test conditions unless otherwise noted: $V_{CC} = +5.0V$, $I_{CC} = 90mA$, $Temp = +25^{\circ}C$, 50Ω system.

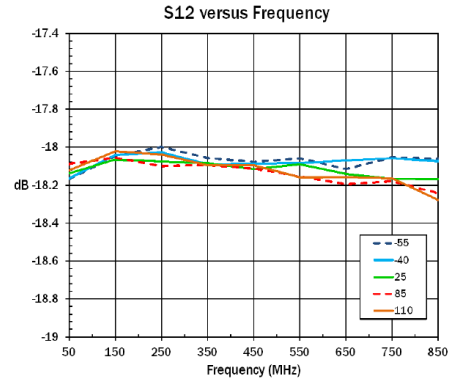
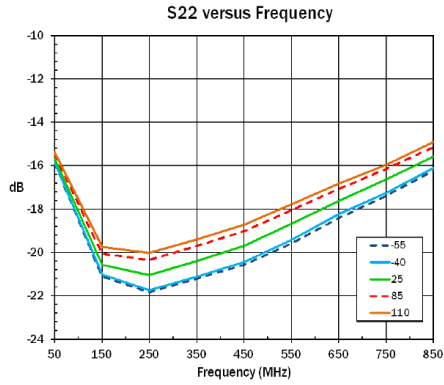
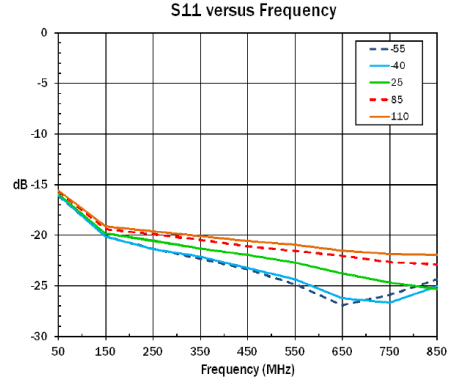
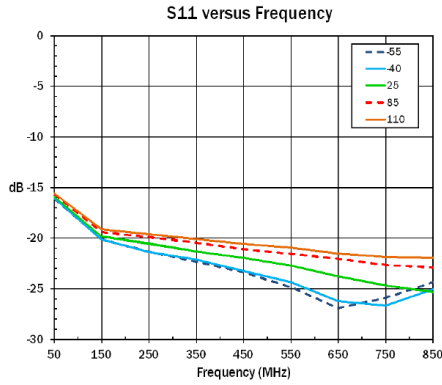

Pin Configuration and Description

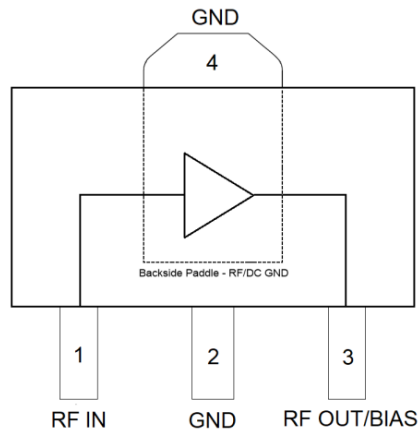

Pin No.	Label	Description
1	RF IN	RF input. External DC Block capacitor required.
2, 4	GND	RF/DC ground. Use recommended via hole pattern to minimize inductance and thermal resistance. See PCB Mounting Pattern for suggested footprint.
3	RF OUT / BIAS	RF output and DC Supply input. External DC Block capacitor and bias voltage required.

Package Marking and Dimensions

Marking: Part Identifier – SBB1089Z
Trace Code – Assigned by sub-contractor

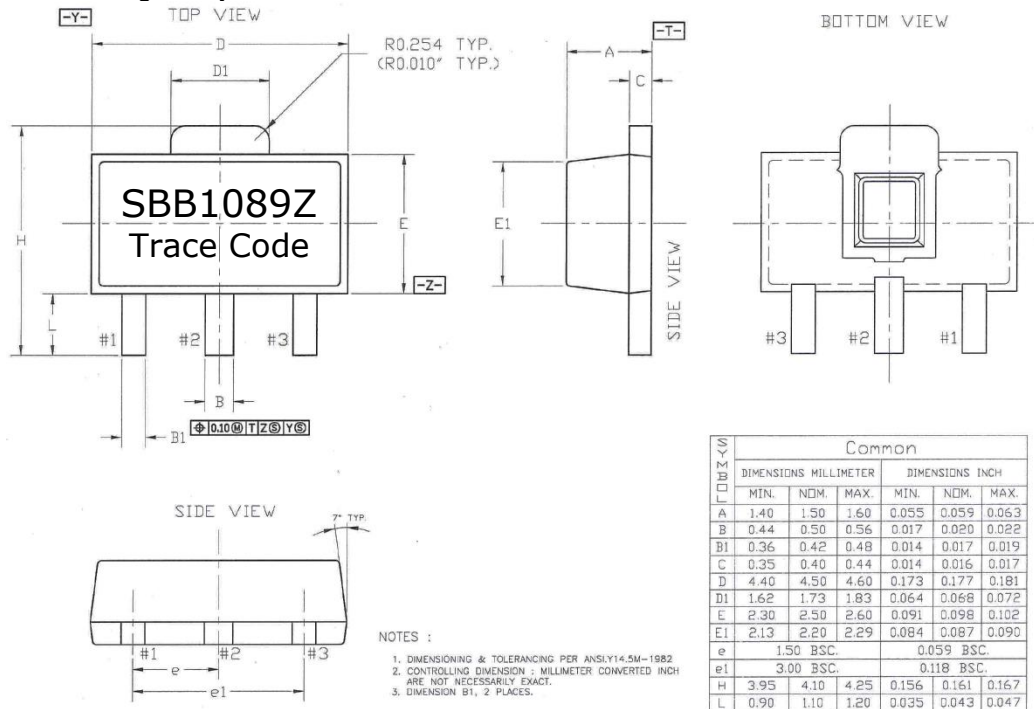

Notes:

1. All dimensions are in millimeters. Angles are in degrees.
2. The terminal #1 identifier and terminal numbering conform to JESD 95-1 SPP-012.

PCB Mounting Pattern

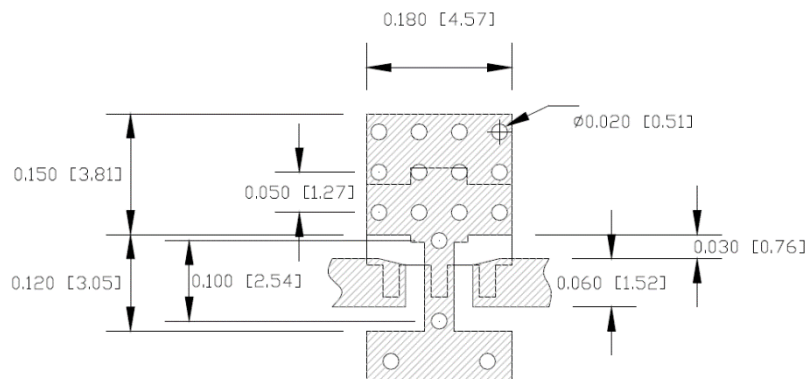

NOTES:

1. All dimensions are in millimeters [inches]. Angles are in degrees.
2. Use 1 oz. copper minimum for top and bottom layer metal.
3. Vias are required under the backside paddle of this device for proper RF/DC grounding and thermal dissipation. We recommend a 0.35mm (#80/.0135") diameter bit for drilling via holes and a final plated thru diameter of 0.25mm (0.01").
4. Ensure good package backside paddle solder attach for reliable operation and best electrical performance.

Tape and Reel Information – Carrier and Cover Tape Dimensions

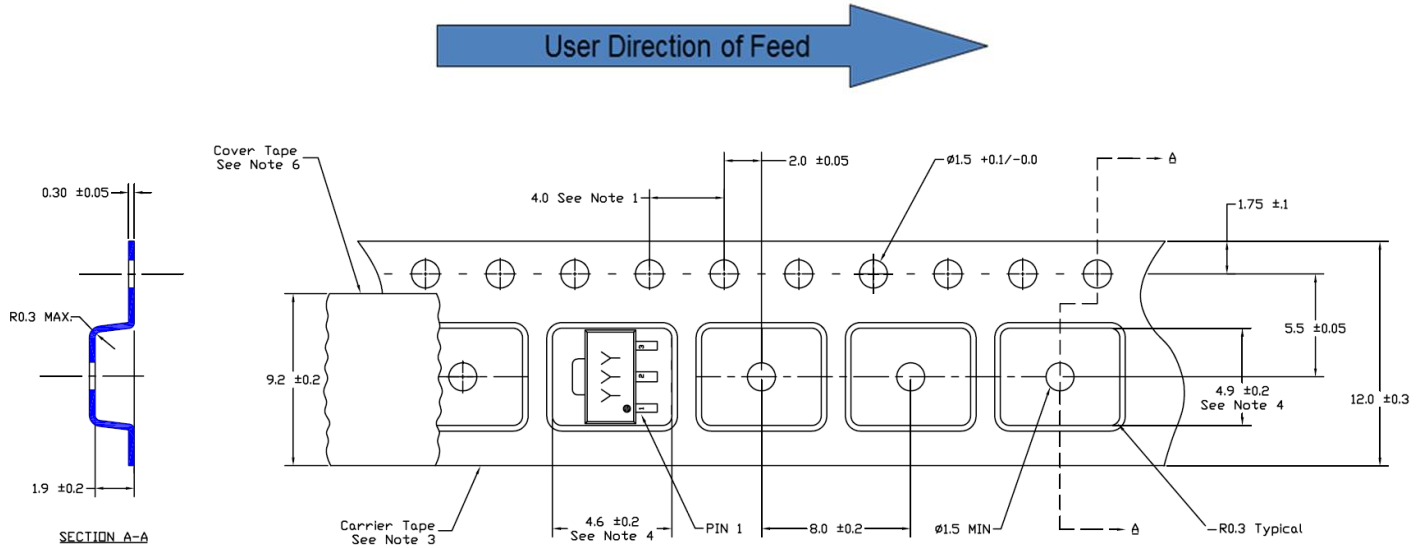

1. 10 sprocket hole pitch cumulative tolerance
2. Camber not to exceed 1mm in 100mm
3. Material: Black Conductive Polystyrene
4. Measured on a plane 0.3mm above the bottom of the pocket
5. Measured from a plane on the inside bottom of the pocket to the top surface of the carrier.
6. Material: Antistatic Polyester Film

Feature	Measure	Symbol	Size (in)	Size (mm)
Cavity	Length	A0	0.181	4.60
	Width	B0	0.193	4.90
	Depth	K0	0.075	1.90
	Pitch	P1	0.315	8.00
Centerline Distance	Cavity to Perforation - Length Direction	P2	0.079	2.00
	Cavity to Perforation - Width Direction	F	0.217	5.50
Cover Tape	Width	C	0.362	9.20
Carrier Tape	Width	W	0.472	12.0

Tape and Reel Information – Reel Dimensions

Standard T/R size = 1,000 pieces on a 7" reel.

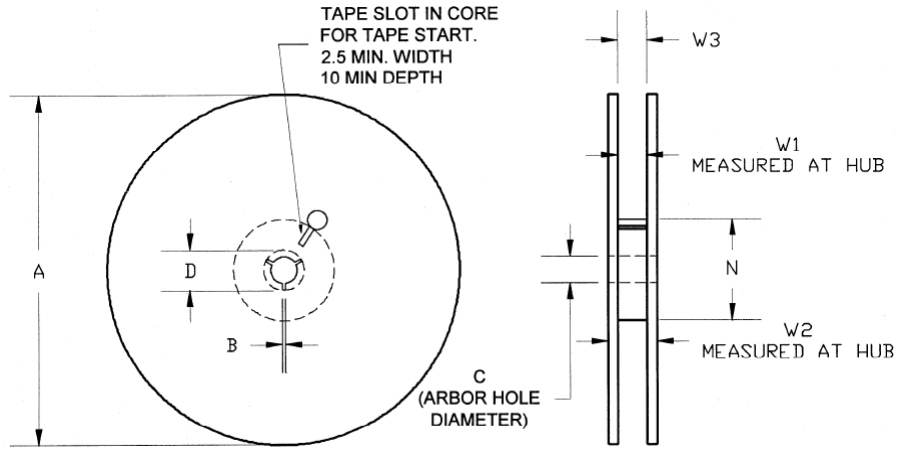

Feature	Measure	Symbol	Size (in)	Size (mm)
Flange	Diameter	A	6.969	177.0
	Thickness	W2	0.717	18.2
	Space Between Flange	W1	0.504	12.8
Hub	Outer Diameter	N	2.283	58.0
	Arbor Hole Diameter	C	0.512	13.0
	Key Slit Width	B	0.079	2.0
	Key Slit Diameter	D	0.787	20.0

Tape and Reel Information – Tape Length and Label Placement



- Notes:
1. Empty part cavities at the trailing and leading ends are sealed with cover tape. See EIA 481-1-A.
 2. Labels are placed on the flange opposite the sprockets in the carrier tape.