

60 Amp Schottky Rectifier

SBR6090 — SBR60100

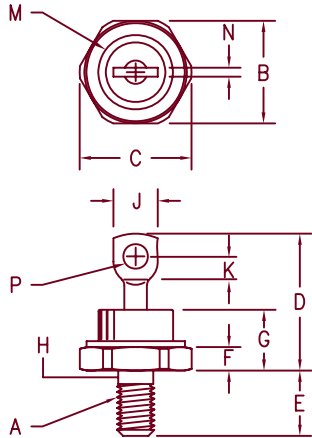

Notes:

1. Full threads within 2 1/2 threads
2. Standard Polarity: Stud is Cathode
Reverse Polarity: Stud is Anode

Dim.	Inches		Millimeter		Notes
	Minimum	Maximum	Minimum	Maximum	
A	----	----	----	----	1/4-28
B	.669	.688	17.00	17.47	
C	----	.794	----	20.16	
D	.750	1.00	19.05	25.40	
E	.422	.453	10.72	11.50	
F	.115	.200	2.93	5.08	
G	----	.450	----	11.43	
H	.220	.249	5.59	6.32	1
J	----	.375	----	9.52	
K	.156	----	3.97	----	
M	----	.510	----	12.95	Dia
N	----	.080	----	2.03	
P	.140	.175	3.56	4.44	Dia

DO-203AB (DO-5)

Microsemi Catalog Number	Industry Part Number	Working Peak Reverse Voltage	Peak Reverse Voltage
SBR6090*	60HQ080 MBR6080	90V	90V
SBR60100*	60HQ100 MBR60100	100V	100V

*Add Suffix R For Reverse Polarity

- Schottky barrier rectifier
- Hermetic packaging
- Guard ring protected
- Reverse Energy Tested
- 175°C junction temperature
- VRRM – 90 to 100 Volts

Electrical Characteristics		
Average forward current	I _{F(AV)} 60 Amps	T _C = 130°C, square wave, R _{θJC} = 1.0 @/W 8.3ms, half sine, T _J = 175°C
Maximum surge current	I _{FSM} 1000 Amps	
Max repetitive peak reverse current	I _{R(OV)} 2 Amp	f = 1 KHz, 25°C, 1 μsec square wave
Max peak forward voltage	V _{FM} .89 Volts	I _{FM} = 60A: 25°C *
Max peak forward voltage	V _{FM} .70 Volts	I _{FM} = 60A: 125°C *
Max peak reverse current	I _{RM} 50 mA	VRRM, T _J = 125°C *
Max peak reverse current	I _{RM} 1.0 mA	VRRM, T _J = 25°C
Typical junction capacitance	C _J 1250 pF	V _R = 5.0V, T _J = 25°C

*Pulse test: Pulse width 300 μsec, Duty cycle 2%

Thermal and Mechanical Characteristics		
Storage temp range	T _{STG}	-65°C to 175°C
Operating junction temp range	T _J	-65°C to 175°C
Maximum thermal resistance	R _{θJC}	1.0°C/W Junction to case
Typical thermal resistance (greased)	R _{θCS}	0.5°C/W Case to sink
Mounting torque		25-30 inch pounds
Weight		.54 ounces (15.3 grams) typical



6 Lake Street
Lawrence, MA 01841
PH: (978) 620-2600
FAX: (978) 689-0803
www.microsemi.com

05-30-07 Rev. 3

SBR6090 — SBR60100

Figure 1
Typical Forward Characteristics

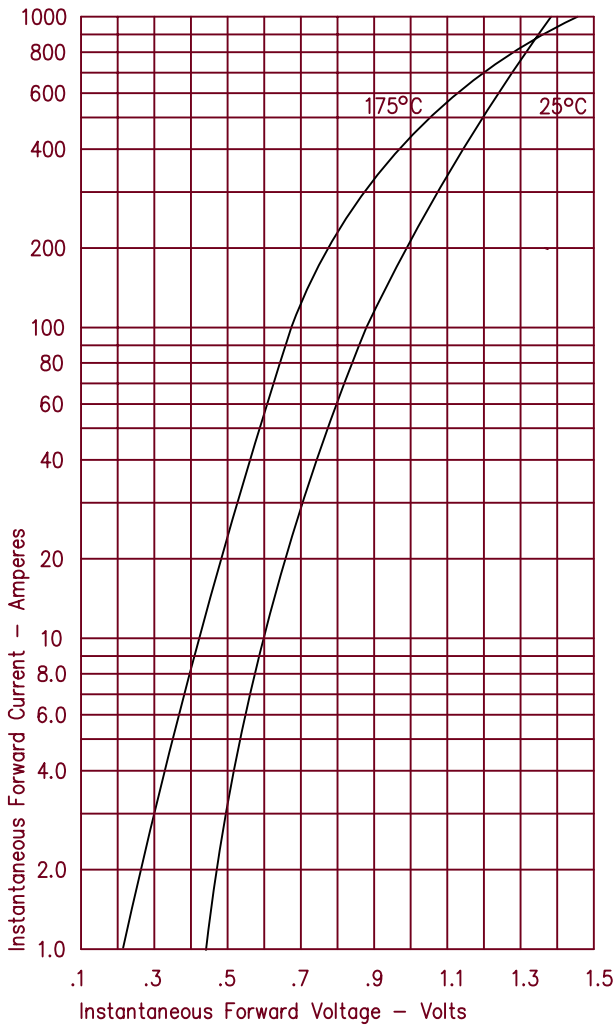

Figure 3
Typical Junction Capacitance

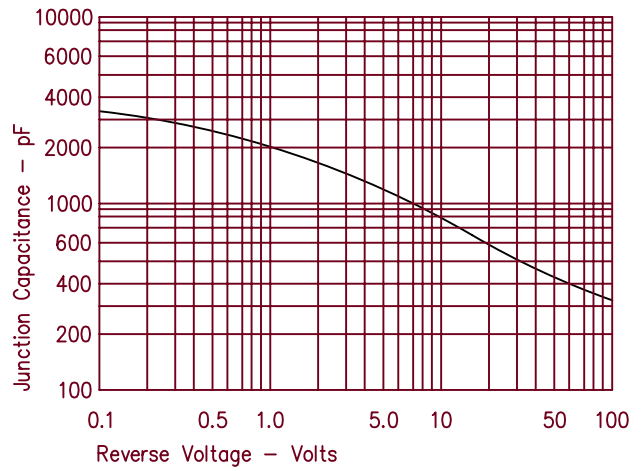

Figure 4
Forward Current Derating

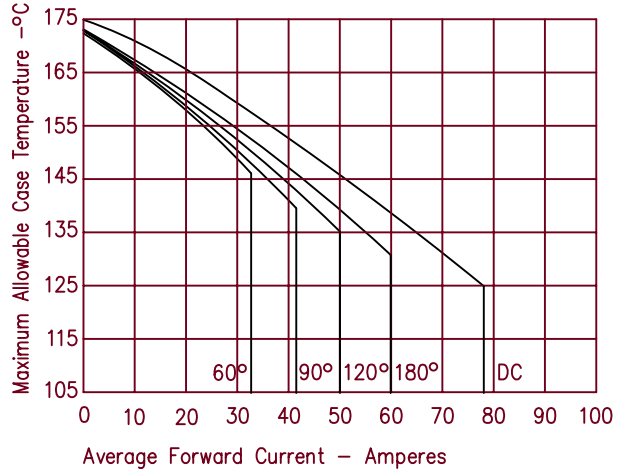

Figure 2
Typical Reverse Characteristics

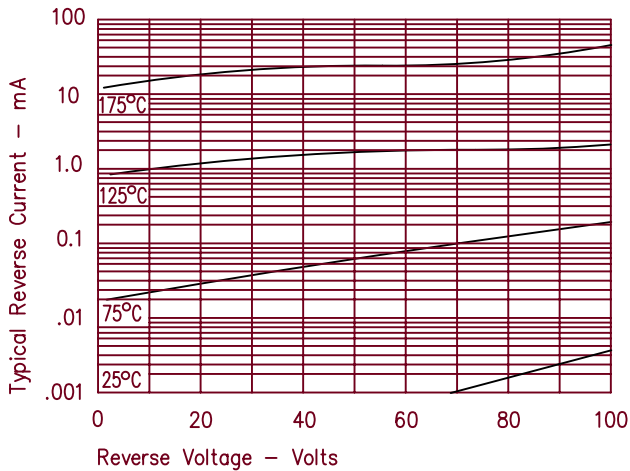

Figure 5
Maximum Forward Power Dissipation

