

Data Sheet SCC30-DB

Humidity and Temperature Sensor Module

- Relative humidity and temperature output
- Superior sensor performance, typical accuracy RH: $\pm 3\%$, T: $\pm 0.3^{\circ}\text{C}$
- Fully calibrated and processed digital signal output
- 2.4 to 5.5V supply voltage range

Product Summary

The RH/T sensor module SCC30-DB is specifically designed to meet the most demanding requirements of home appliance applications as well as of other applications, which require sensing remotely from the main control board. It offers the superior sensor performance of capacitive type sensor elements and a very attractive price/performance ratio due to Sensirion's latest generation of highly integrated humidity and temperature sensors (SHT3x). This SHT3x platform incorporates more than ten years of knowledge of Sensirion, the leader in the humidity sensor industry.

Customer Benefits:

- High reliability & excellent long-term stability due to capacitive type sensor
- Versatile low cost sensor module
- Broad and competent application support by Sensirion.

1 Product Description

The SCC30-DB is a humidity and temperature sensor module with digital I²C output, consisting of a SHT30-DIS humidity and temperature sensor mounted on a PCB with connector.



Figure 1. SCC30-DB

2 Sensor Specifications

Relative Humidity

Parameter	Condition	Typical Value	Units
Accuracy Tolerance ¹	10 to 90 %RH	±3	%RH
Operating Range	non-condensing environment ²	0-100	%RH
Hysteresis	-	< ±0.8	%RH
Long Term Drift ³	-	< 0.25	%RH/yr
Response time ⁴	τ 63%	8	s

Table 1. Relative Humidity Performance Specification

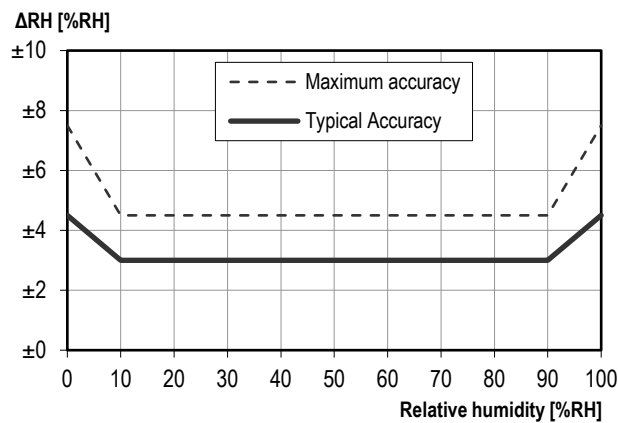

Figure 2. Relative Humidity Accuracy Specification.

Temperature

Parameter	Condition	Typical Value	Units
Accuracy Tolerance	0 to 65°C	±0.3	°C
Operating Range	-	-20 to +85	°C
Storage Range	-	-25 to +85	°C
Long Term Drift	-	< 0.04	°C/yr
Response Time ⁵	τ 63%	45	s

Table 2. Temperature Performance Specification

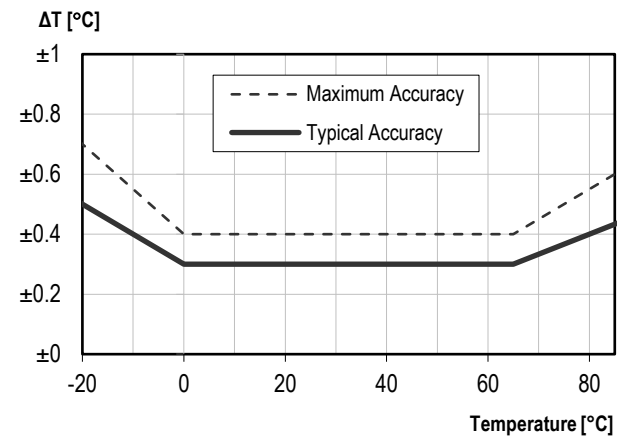

Figure 3. Temperature Accuracy Specification

¹ For definition of typical and maximum accuracy tolerance, please refer to the document "Sensirion Humidity Sensor Specification Statement".

² Condensation shall be avoided because of risk of corrosion and leak currents on the PCB.

³ Typical value for operation in normal RH/T operating range, see section 2.1. Maximum value is < 0.5 %RH/yr. Value may be higher in environments with

vaporized solvents, out-gassing tapes, adhesives, packaging materials, etc. For more details please refer to Handling Instructions.

⁴ Time for achieving 63% of a humidity step function, valid at 25°C and 1m/s airflow. Humidity response time in the application depends on the design-in of the sensor.

⁵ Response time is measured when the sensor is exchanged between water reservoirs of different temperatures

2.1 Recommended Operating Conditions

The sensor shows best performance when operated within recommended normal temperature and humidity range of 5 °C – 60 °C and 20 %RH – 80 %RH, respectively. Long-term exposure to conditions outside normal range, especially at high humidity, may temporarily offset the RH signal (e.g. +3%RH after 60h kept at >80%RH). After returning into the normal temperature and humidity range the sensor will slowly come back to calibration state by itself. Prolonged exposure to extreme conditions may accelerate ageing.

3 Electrical Specifications

3.1 Electrical Characteristics

Parameter	Symbol	Condition	Min.	Typ.	Max.	Units	Comments
Supply voltage	V_{DD}		2.4	3.3	5.5	V	
Power-up/down level	V_{POR}		1.8	2.1	2.4	V	
Slew rate change of the supply voltage	$V_{DD,slew}$		-	-	20	V/ms	Voltage changes on the VDD line between $V_{DD,min}$ and $V_{DD,max}$ should be slower than the maximum slew rate; faster slew rates may lead to reset;
Supply current	I_{DD}	idle state (single shot mode)	-	0.2	2.0	μA	Current when sensor is not performing a measurement during single shot mode
		idle state (periodic data acquisition mode)	-	45	-	μA	Current when sensor is not performing a measurement during periodic data acquisition mode
		Measuring	-	800	1500	μA	Current consumption while sensor is measuring
		Average	-	2	-	μA	Current consumption (operation with one measurement per second at lowest repeatability, single shot mode)

Table 3. Electrical specifications, values measured at 25°C.

3.2 Timing Specifications

Parameter	Symbol	Conditions	Min.	Typ.	Max.	Units	Comments
Power-up time	t_{PU}	After hard reset, $V_{DD} \geq V_{POR}$	-	0.5	1.5	ms	Time between VDD reaching VPOR and sensor entering idle state
Soft reset time	t_{SR}	After soft reset.	-	0.5	1.5	ms	Time between ACK of soft reset command and sensor entering idle state
Measurement duration	$t_{MEAS,l}$	Low repeatability	-	2.5	4.5	ms	The three repeatability modes differ with respect to measurement duration, noise level and energy consumption.
	$t_{MEAS,m}$	Medium repeatability	-	4.5	6.5	ms	
	$t_{MEAS,h}$	High repeatability	-	12.5	15.5	ms	

Table 4. System timing specifications, valid from -40 °C to 125 °C and VDDmin to VDDmax

3.3 Absolute Minimum and Maximum Ratings

Stress levels beyond those listed in **Table 5** may cause permanent damage to the device or affect the reliability of the sensor. These are stress ratings only and functional operation of the device at these conditions cannot be guaranteed.

Parameter	Rating	Units
Supply voltage V_{DD}	-0.3 to 6	V
Max Voltage on pins SDA and SCL	-0.3 to VDD+0.3	V
Input current on any pin	± 100	mA
Temperature range	-25 to 85	°C
ESD HBM (human body model) ⁶	4	kV

Table 5. Absolute minimum and maximum ratings; values are target specs and not confirmed by measurements yet

4 Pin Assignment

The connector of the SCC30-DB is Scondar SCT2001WR-S-4P (compatible to JST part no. S4B-PH-SM4-TB).

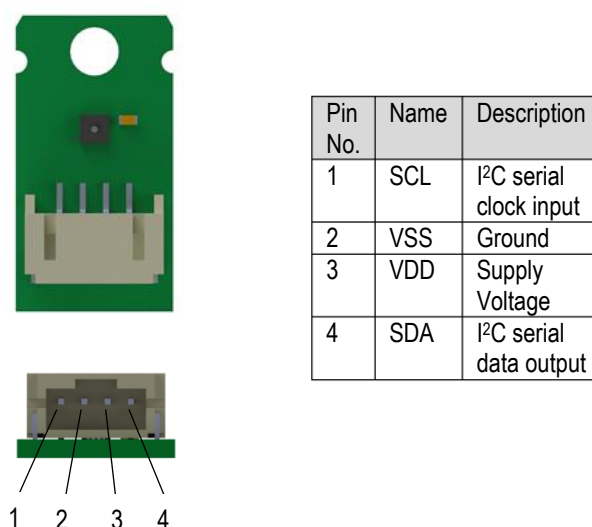

Figure 4. Connector pin assignment of the SCC30-DB module.

⁶ According to JEDEC JS-001

4.1 Typical Application Circuit

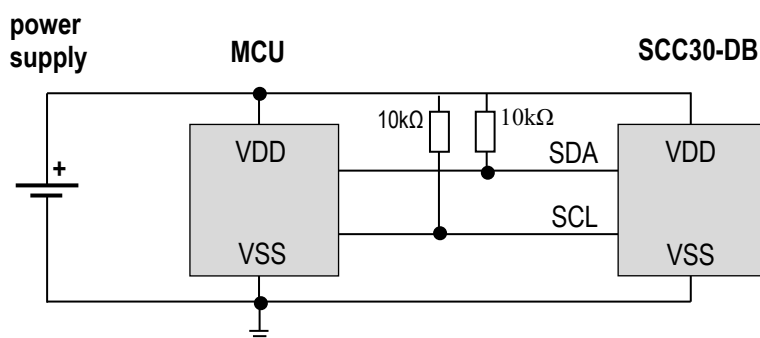

Figure 5. Typical application circuit for the SCC30-DB module.

5 Operation and Communication

The SCC30-DB supports I²C normal and fast mode. Low frequencies (below 100 kHz) are recommended for applications where the module is connected by a cable because of capacitive coupling of cables with the I²C bus. For detailed information on the I²C protocol, refer to NXP I²C-bus specification⁷.

After sending a command to the sensor a minimal waiting time of 1ms is needed before another command can be received by the sensor. Furthermore, to keep self-heating below 0.1°C, the SCC30-DB should not be active for more than 10% of the time. All SCC30-DB commands and data are mapped to a 16-bit address space. Additionally, data and commands are protected with a CRC checksum. This increases communication reliability. The 16 bits commands to the sensor already include a 3 bit CRC checksum. Data sent from and received by the sensor is always succeeded by an 8 bit CRC.

In write direction it is mandatory to transmit the checksum, since the SCC30-DB only accepts data if it is followed by the correct checksum. In read direction it is left to the master to read and process the checksum.

5.1 I²C Address

The I²C device address is given

Table 6:

SCC30-DB	Hex. Code	Bin. Code
I ² C address	0x44	1000100

Table 6. SCC30-DB I²C device address.

Each transmission sequence begins with START condition (S) and ends with an (optional) STOP condition (P) as described in the I²C-bus specification.

5.2 Power-Up and Communication Start

The sensor starts powering-up after reaching the power-up threshold voltage V_{POR} specified in Table 3. After reaching this threshold voltage the sensor needs the time t_{PU} to enter idle state. Once the idle state is entered it is ready to receive commands from the master (microcontroller).

Each transmission sequence begins with a START condition (S) and ends with a STOP condition (P) as described in the I²C-bus specification. Whenever the sensor is powered up, but not performing a measurement or communicating, it automatically enters idle state for energy saving. This idle state cannot be controlled by the user.

5.3 Starting a Measurement

A measurement communication sequence consists of a START condition, the I²C write header (7-bit I²C device address plus 0 as the write bit) and a 16-bit measurement command. The proper reception of each byte is indicated by the sensor. It pulls the SDA pin low (ACK bit) after the falling edge of the 8th SCL clock to indicate the reception. A complete measurement cycle is depicted in Table 7.

With the acknowledgement of the measurement command, the SCC30-DB starts measuring humidity and temperature.

⁷ http://www.nxp.com/documents/user_manual/UM10204.pdf

5.4 Measurement Commands for Single Shot Data Acquisition Mode

In this mode one issued measurement command triggers the acquisition of *one data pair*. Each data pair consists of one 16-bit temperature and one 16-bit humidity value (in this order). During transmission each data value is always followed by a CRC checksum, see Section 5.5.

The single shot mode allows different measurement commands. The 16-bit commands are shown in Table 7. They differ with respect to repeatability (low, medium and high). The repeatability setting influences the measurement duration and thus the overall energy consumption of the sensor. This is explained in Section 3.

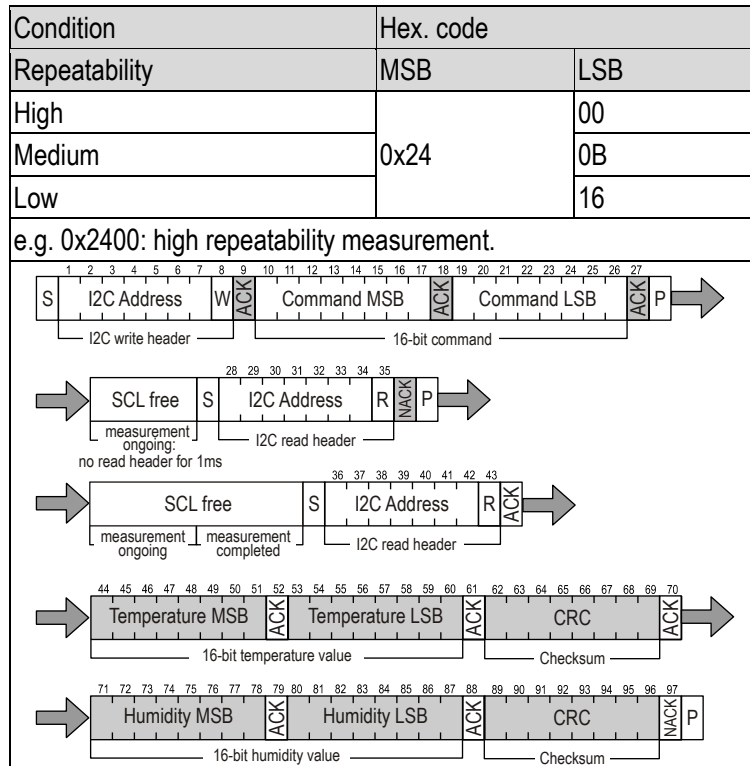

Table 7. Measurement commands in single shot mode. The first “SCL free” caters a minimal waiting time of 1ms. (Clear blocks are controlled by the roller, grey blocks by the sensor).

5.5 Readout of Measurement Results for Single Shot Mode

After the sensor has completed the measurement, the master can read the measurement results (pair of RH & T) by sending a START condition followed by an I2C read header. The sensor responds to a read header with a not acknowledge (NACK), if the measurement is still ongoing and thus no data is present.

If the measurement is completed, the sensor will acknowledge the reception of the read header and send two bytes of data (temperature) followed by one byte CRC checksum and another two bytes of data (relative humidity) followed by one byte CRC checksum. Each byte must be acknowledged by the microcontroller with an ACK condition for the sensor to continue sending data. If the sensor does not receive an ACK from the master after any byte of data, it will not continue sending data.

The sensor will send the temperature value first and then the relative humidity value. After having received the checksum for the humidity value a NACK and stop condition should be sent (see Table 7).

The I2C master can abort the read transfer with a NACK condition after any data byte if it is not interested in subsequent data, e.g. the CRC byte or the second measurement result, in order to save time.

In case the user needs humidity and temperature data but does not want to process CRC data, we recommend to read the two temperature bytes of data with the CRC byte (without processing the CRC data); after having read the two humidity bytes, the read transfer can be aborted with a with a NACK.

5.6 Measurement Commands for Periodic Data Acquisition Mode

In this mode one issued measurement command yields a *stream of data pairs*. Each data pair consists of one 16-bit temperature and one 16-bit humidity value (in this order). In periodic mode different measurement commands can be selected. The corresponding 16-bit commands are shown in Table 8. They differ with respect to repeatability (low, medium and high) and data acquisition frequency (0.5, 1, 2, 4 & 10 measurements per second, mps). The data acquisition frequency and the repeatability

setting influences the measurement duration and the current consumption of the sensor. This is explained in Section 3 of this datasheet. If a measurement command is issued, while the sensor is busy with a measurement (measurement durations see **Table 4**), we recommend to issue a break command first (see Section 5.9). Upon reception of the break command the sensor will abort the ongoing measurement and enter the single shot mode.

Condition		Hex. code	
Repeatability	mps	MSB	LSB
High	0.5	0x20	32
Medium			24
Low			2F
High	1	0x21	30
Medium			26
Low			2D
High	2	0x22	36
Medium			20
Low			2B
High	4	0x23	34
Medium			22
Low			29
High	10	0x27	37
Medium			21
Low			2A
e.g. 0x2130: 1 high repeatability mps - measurement per second			

Table 8. Measurement commands for periodic data acquisition mode (Clear blocks are controlled by the microcontroller, grey blocks by the sensor). N.B.: At the highest mps setting self-heating of the sensor might occur.

5.7 Readout of Measurement Results for Periodic Mode

Transmission of the measurement data can be initiated through the fetch data command shown in **Table 9**. If no measurement data is present the I²C read header is responded with a NACK (Bit 9 in **Table 9**) and the communication stops. After the read out command fetch data has been issued, the data memory is cleared, i.e. no measurement data is present.

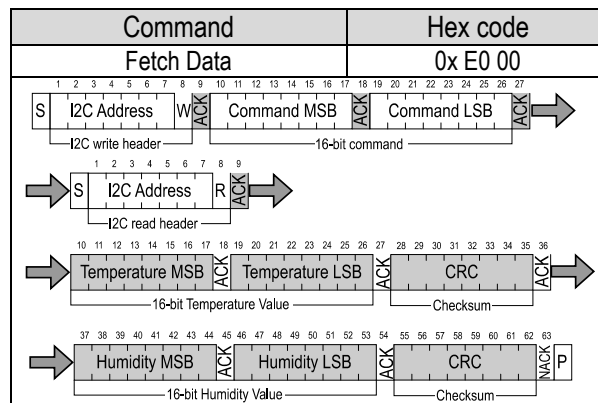

Table 9. Fetch Data command (Clear blocks are controlled by the microcontroller, grey blocks by the sensor).

5.8 ART Command

The ART (accelerated response time) feature can be activated by issuing the command in **Table 10**. After issuing the ART command the sensor will start acquiring data with a frequency of 4Hz.

The ART command is structurally similar to any other command in Table 8. Hence Section 5.6 applies for starting a measurement, Section 0 for reading out data and Section 5.9 for stopping the periodic data acquisition.

The ART feature can also be evaluated using the Evaluation Kit EK-H5 from Sensirion.

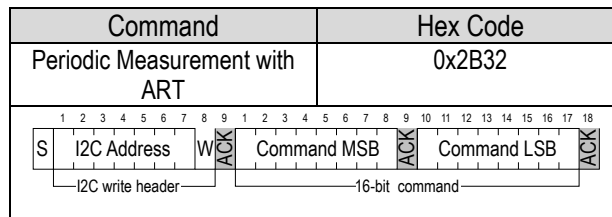

Table 10. Command for a periodic data acquisition with the ART feature (Clear blocks are controlled by the microcontroller, grey blocks by the sensor).

5.9 Break Command / Stop Periodic Data Acquisition Mode

The periodic data acquisition mode can be stopped using the break command shown in **Table 11**, which we recommend to do prior to sending another command (except Fetch Data command). Upon reception of the break command the sensor will abort the ongoing measurement and enter the single shot mode. This takes 1ms.

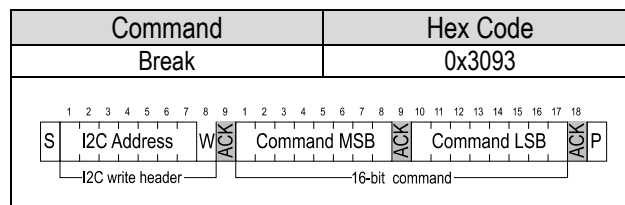

Table 11. Break command (Clear blocks are controlled by the microcontroller, grey blocks by the sensor).

5.10 Reset

A system reset of the SCC30-DB can be generated externally by issuing a command (soft reset). Additionally, a system reset is generated internally during power-up. During the reset procedure the sensor will not process commands.

Interface Reset

If communication with the device is lost, the following signal sequence will reset the serial interface: While leaving SDA high, toggle SCL nine or more times. This must be followed by a Transmission Start sequence preceding the next command. This sequence resets the interface only. The status register preserves its content.

Soft Reset / Re-Initialization

The SCC30-DB provides a soft reset mechanism that forces the system into a well-defined state without removing the power supply. When the system is in idle state the soft reset command can be sent to the SCC30-DB. This triggers the sensor to reset its system controller and reloads calibration data from the memory. In order to start the soft reset procedure the command as shown in **Table 12** should be sent.

It is worth noting that the sensor reloads calibration data prior to every measurement by default.

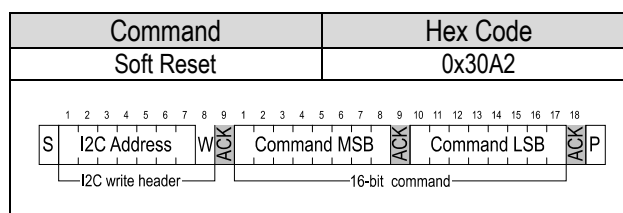

Table 12. Soft reset command (Clear blocks are controlled by the microcontroller, grey blocks by the sensor).

Reset through General Call

Additionally, a reset of the sensor can also be generated using the “general call” mode according to I²C-bus specification⁷. It is important to understand that a reset generated in this way is not device specific. All devices on the same I²C bus that support the general call mode will perform a reset. Additionally, this command only works when the sensor is able to process I²C commands. The appropriate command consists of two bytes and is shown in **Table 13**.

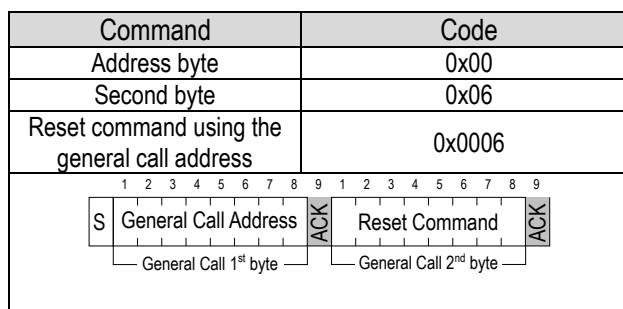

Table 13. Reset through the general call address (Clear blocks are controlled by the microcontroller, grey blocks by the sensor).

Hard Reset

A hard reset is achieved by switching the supply voltage to the VDD Pin off and then on again. In order to prevent powering the sensor over the ESD diodes, the voltage to pins 1 (SCL) and 4 (SDA) also needs to be removed.

5.11 Heater

The SHT3x sensor on the SCC30-DB is equipped with an internal heater, which is meant for plausibility checking only. The temperature increase achieved by the heater depends on various parameters, and lies in the range of a few degrees centigrade. It can be switched on and off by command, see **Table 14** below. The status is listed in the status register. After a reset the heater is disabled (default condition).

Command	Hex Code	
	MSB	LSB
Heater Enable	0x30	6D
Heater Disabled		66

The diagram illustrates the I2C write sequence for a 16-bit command. It starts with a Start (S) signal, followed by the 7-bit I2C Address. A Write Acknowledge (WACK) signal is received at bit 9. The 16-bit command is then transmitted, split into Command MSB (bits 1-8) and Command LSB (bits 9-16). The sequence ends with a Stop (P) signal.

Table 14. Heater command (Clear blocks are controlled by the microcontroller, grey blocks by the sensor).

5.12 Status Register

The status register contains information on the operational status of the heater, the alert mode and on the execution status of the last command and the last write sequence. The command to read out the status register is shown in **Table 15** whereas a description of the content can be found in **Table 16**.

Command	Hex code
Read Out of status register	0xF32D

The diagram illustrates the I2C read sequence for the status register. It starts with a Start (S) signal, followed by the 7-bit I2C Address. A Read Acknowledge (RACK) signal is received at bit 9. The 16-bit status register content is then transmitted, split into Register MSB (bits 1-8) and Register LSB (bits 9-16). The sequence ends with a Stop (P) signal. A CRC checksum (bits 28-35) is also shown, which is controlled by the microcontroller.

Table 15. Command to read out the status register (Clear blocks are controlled by the microcontroller, grey blocks by the sensor).

Bit	Field description	Default value
15	Reserved	'1'
14	Reserved	'0'
13	Heater status '0': Heater OFF '1': Heater ON	'0'
12	Reserved	'0'
11	Reserved	'0'
10	Reserved	'0'
9:5	Reserved	'xxxxx'
4	System reset detected '0': no reset detected since last 'clear status register' command '1': reset detected (hard reset, soft reset command or supply fail)	'1'
3:2	Reserved	'00'
1	Command status '0': last command executed successfully '1': last command not processed. It was either invalid, failed the integrated command checksum	'0'
0	Write data checksum status '0': checksum of last write transfer was correct '1': checksum of last write transfer failed	'0'

Table 16. Description of the status register.

Clear Status Register

All flags (Bit 15, 11, 10, 4) in the status register can be cleared (set to zero) by sending the command shown in **Table 17**.

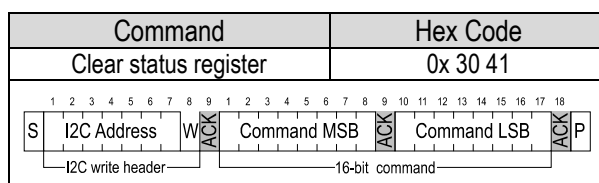

Table 17. Command to clear the status register (Clear blocks are controlled by the microcontroller, grey blocks by the sensor)

5.13 Checksum Calculation

The 8-bit CRC checksum transmitted after each data word is generated by a CRC algorithm (Table 18). The CRC covers the contents of the two previously transmitted data bytes and is calculated by using only these two previously transmitted data bytes.

Property	Value
Name	CRC-8
Width	8 bit
Protected data	read and/or write data
Polynomial	0x31 ($x^8 + x^5 + x^4 + 1$)
Initialization	0xFF
Reflect input	False
Reflect output	False
Final XOR	0x00
Examples	CRC (0xBEEF) = 0x92

Table 18. I²C CRC properties.

5.14 Conversion of Signal Output

Measurement data is always transferred as 16-bit values (unsigned integer). These values are already linearized and compensated for temperature and supply voltage effects. Converting those raw values into a physical scale can be achieved using the following formulas.

Relative humidity conversion formula (result in %RH):

$$RH = 100 \cdot \frac{S_{RH}}{2^{16} - 1}$$

Temperature conversion formula (result in °C & °F):

$$T [^{\circ}C] = -45 + 175 \cdot \frac{S_T}{2^{16} - 1}$$

$$T [^{\circ}F] = -49 + 315 \cdot \frac{S_T}{2^{16} - 1}$$

S_{RH} and S_T denote the raw sensor output for humidity and temperature, respectively. The formulas work only correctly when S_{RH} and S_T are used in decimal representation.

5.15 Communication Timing

Parameter	Symbol	Conditions	Min.	Typ.	Max.	Units	Comments
SCL clock frequency	f_{SCL}		0	-	1000	kHz	Max frequency is more than specified by fast mode. Low frequencies (below 100 kHz) are recommended for applications where the module is connected by a cable.
Hold time (repeated) START condition	$t_{HD;STA}$	After this period, the first clock pulse is generated	0.24	-	-	μs	
LOW period of the SCL clock	t_{LOW}		0.53	-	-	μs	
HIGH period of the SCL clock	t_{HIGH}		0.26	-	-	μs	
SDA hold time	$t_{HD;DAT}$		0	-	250	ns	Transmitting data
			0	-	-	ns	Receiving data
SDA set-up time	$t_{SU;DAT}$		100	-	-	ns	
SCL/SDA rise time	t_R		-	-	300	ns	
SCL/SDA fall time	t_F		-	-	300	ns	
SDA valid time	$t_{VD;DAT}$		-	-	0.9	μs	
Set-up time for a repeated START condition	$t_{SU;STA}$		0.26	-	-	μs	
Set-up time for STOP condition	$t_{SU;STO}$		0.26	-	-	μs	
Capacitive load on bus line	CB		-	-	400	pF	
Low level input voltage	V_{IL}		0	-	$0.3 \times V_{DD}$	V	
High level input voltage	V_{IH}		$0.7 \times V_{DD}$	-	$1 \times V_{DD}$	V	
Low level output voltage	V_{OL}	3 mA sink current	-	-	0.4	V	

Table 19. Timing specifications for I²C communication, valid for T=-40°C - 125°C and VDD = VDDmin - VDDmax. The nomenclature above is according to the I²C Specification (UM10204, Rev. 6, April 4, 2014).

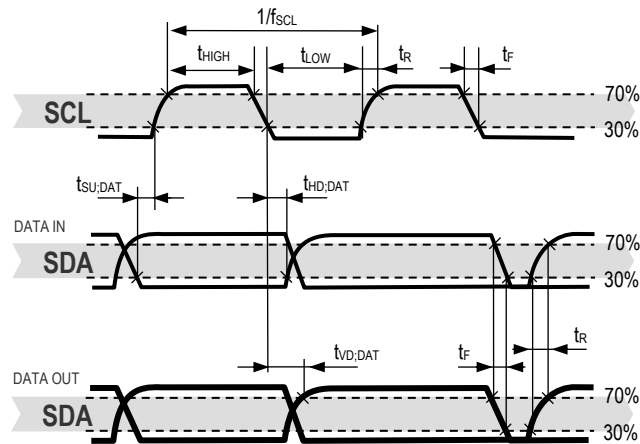

Figure 6. Timing diagram for digital input/output pads. SDA directions are seen from the sensor. Bold SDA lines are controlled by the sensor, plain SDA lines are controlled by the micro-controller. Note that SDA valid read time is triggered by falling edge of preceding toggle.

6 Mechanical

6.1 Mounting Recommendations

The SCC30-DB module is designed for clip or screw mount. Metallic areas of the SCC30-DB module must not be in contact with electrically conducting materials of the end-product. When screw mount is used, care must be taken to not damage the PCB and use of a plastic spacer is recommended.

6.2 Outer Dimensions SCC30-DB

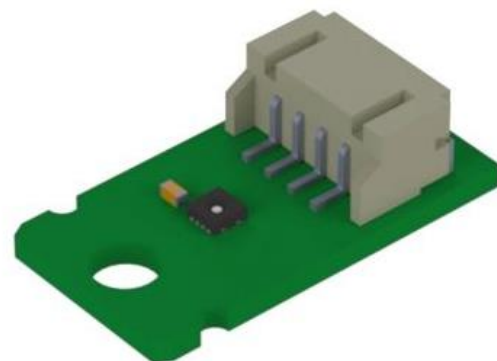
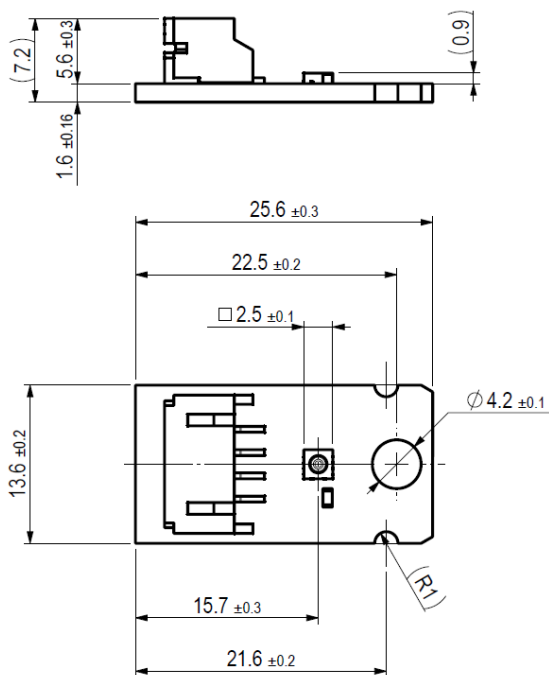

Figure 7. Outer dimensions of the SCC30-DB module.

7 Quality

The qualification of the SHT30 sensor which is mounted on the SCC30-DB is performed based on the JEDEC JESD47 qualification test method. Visual optical acceptance criteria of the SCC30-DB PCB are according to IPC-A-610, class II.

Revision History

Date	Version	Page(s)	Changes
03. June 2020	2	4	Figure 4. Corrected pin assignment.
17. September 2018	1	all	Initial version.