



## SD57030-01

### RF POWER TRANSISTORS

#### The *LdmoST* FAMILY

#### N-CHANNEL ENHANCEMENT-MODE LATERAL MOSFETs

- EXCELLENT THERMAL STABILITY
- COMMON SOURCE CONFIGURATION
- P<sub>OUT</sub> = 30 W WITH 13 dB gain @ 945 MHz
- BeO FREE PACKAGE

#### DESCRIPTION

The SD57030-01 is a common source N-Channel enhancement-mode lateral Field-Effect RF power transistor designed for broadband commercial and industrial applications at frequencies up to 1.0 GHz. The SD57030-01 is designed for high gain and broadband performance operating in common source mode at 28 V. It is ideal for base station applications requiring high linearity.

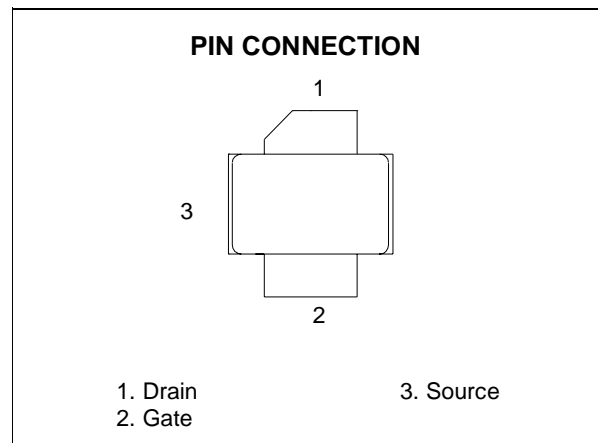
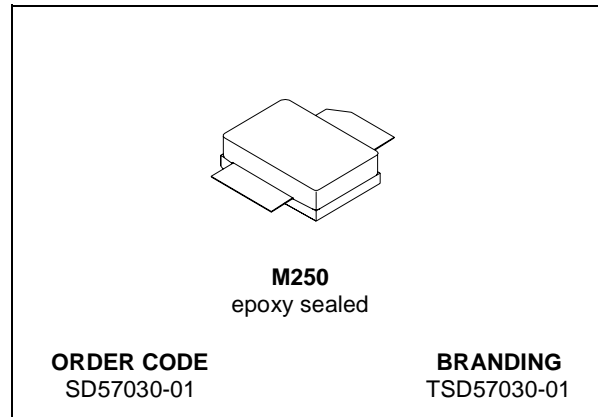

#### ABSOLUTE MAXIMUM RATINGS (T<sub>CASE</sub> = 25°C)

Symbol	Parameter	Value	Unit
V <sub>(BR)DSS</sub>	Drain-Source Voltage	65	V
V <sub>DGR</sub>	Drain-Gate Voltage (R <sub>GS</sub> = 1 MΩ)	65	V
V <sub>GS</sub>	Gate-Source Voltage	+ 20	V
I <sub>D</sub>	Drain Current	4	A
P <sub>DISS</sub>	Power Dissipation (@ T <sub>c</sub> = 70°C)	74	W
T <sub>j</sub>	Max. Operating Junction Temperature	200	°C
T <sub>STG</sub>	Storage Temperature	-65 to + 200	°C

#### THERMAL DATA

R <sub>th(j-c)</sub>	Junction -Case Thermal Resistance	1.75	°C/W
----------------------	-----------------------------------	------	------

ELECTRICAL SPECIFICATION ( $T_{CASE} = 25^{\circ}C$ )

## STATIC

Symbol	Test Conditions		Min.	Typ.	Max.	Unit
$V_{(BR)DSS}$	$V_{GS} = 0 V$	$I_{DS} = 10 mA$	65			V
$I_{DSS}$	$V_{GS} = 0 V$	$V_{DS} = 28 V$			1	$\mu A$
$I_{GSS}$	$V_{GS} = 20 V$	$V_{DS} = 0 V$			1	$\mu A$
$V_{GS(Q)}$	$V_{DS} = 28 V$	$I_D = 50 mA$	2.0		5.0	V
$V_{DS(ON)}$	$V_{GS} = 10 V$	$I_D = 3 A$		1.3		V
$G_{FS}$	$V_{DS} = 10 V$	$I_D = 3 A$		1.8		mho
$C_{ISS}^*$	$V_{GS} = 0 V$	$V_{DS} = 28 V$		58		pF
$C_{OSS}$	$V_{GS} = 0 V$	$V_{DS} = 28 V$		34		pF
$C_{RSS}$	$V_{GS} = 0 V$	$V_{DS} = 28 V$		2.7		pF

Ref. 7143417B

## DYNAMIC

Symbol	Test Conditions		Min.	Typ.	Max.	Unit
$P_{OUT}$	$V_{DD} = 28 V$	$I_{DQ} = 50 mA$	30			W
$G_{PS}$	$V_{DD} = 28 V$	$I_{DQ} = 50 mA$	13	15		dB
$\eta_D$	$V_{DD} = 28 V$	$I_{DQ} = 50 mA$	50	60		%
Load mismatch	$V_{DD} = 28 V$	$I_{DQ} = 50 mA$	10:1			VSWR

## TYPICAL PERFORMANCE (CW)

Output Power vs. Input Power

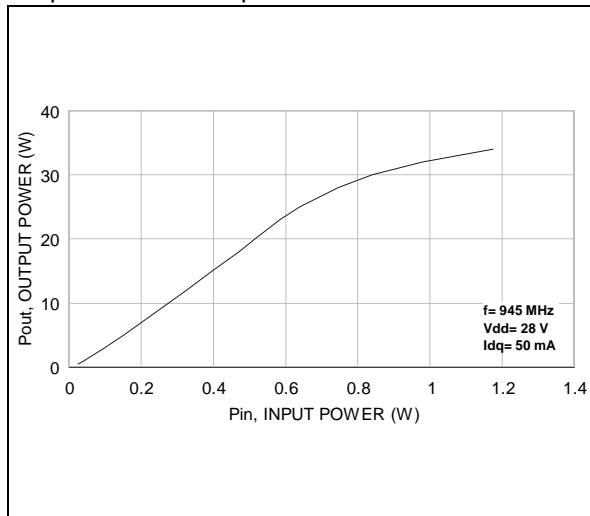

Power Gain and Efficiency vs. Output Power

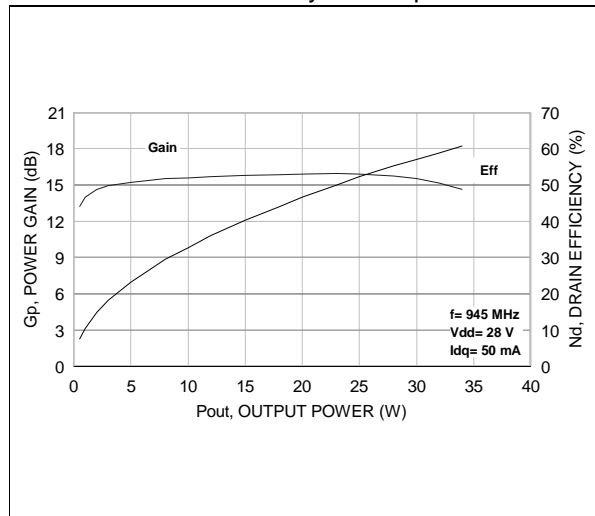

Output Power vs. Gate Source Voltage

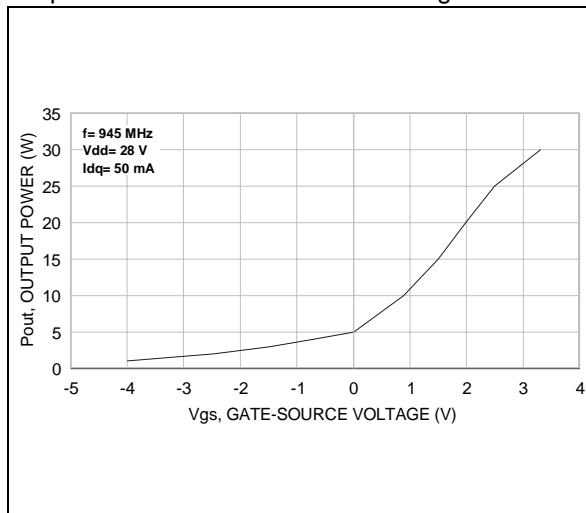

Output Power vs. Supply Voltage

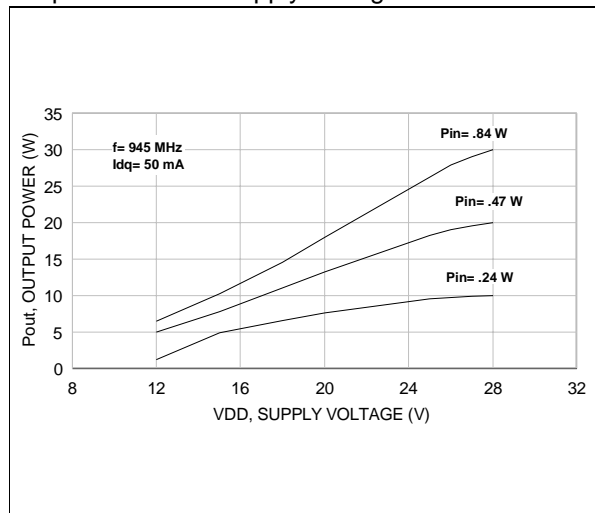

TEST CIRCUIT SCHEMATIC

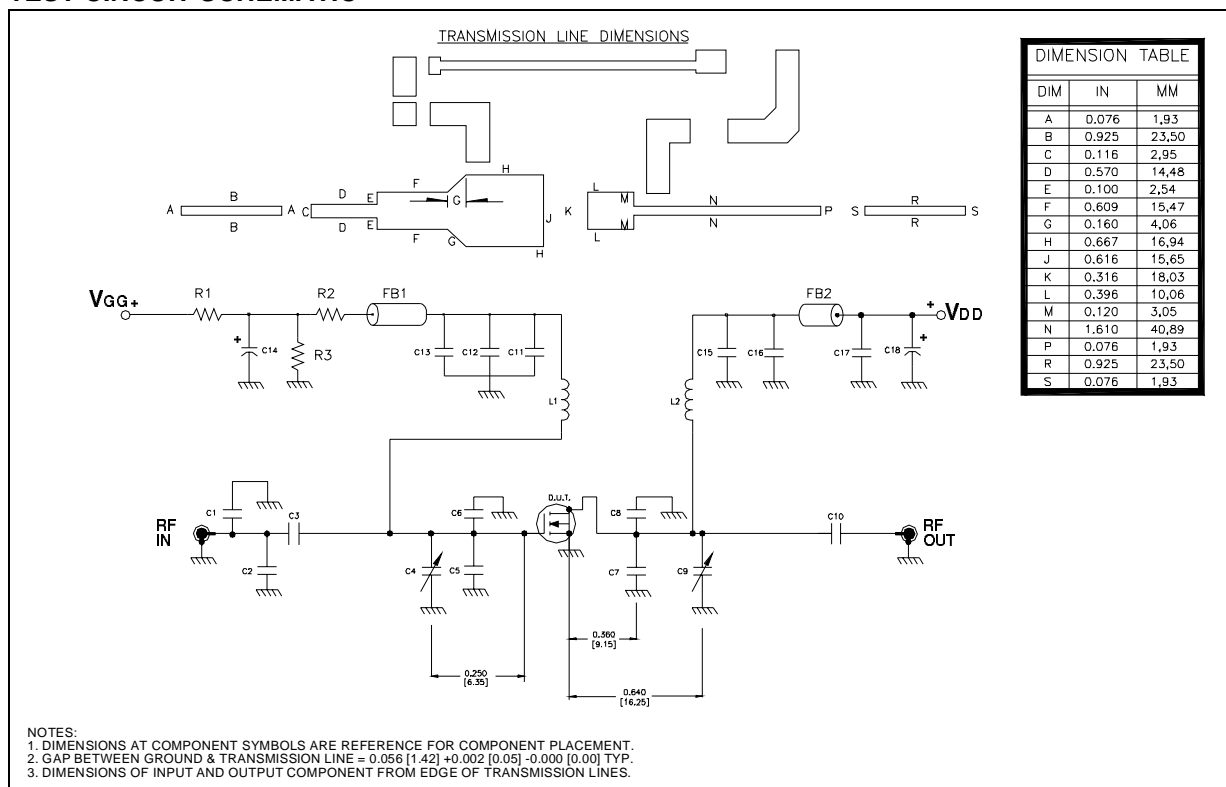

TEST CIRCUIT COMPONENT PART LIST

COMPONENT	DESCRIPTION
C19	200 μF / 63V ALLUMINIUM ELECTROLYTIC RADIAL LEAD CAPACITOR
C18, C14	0.1 μF / 500V SURFACE MOUNT CERAMIC CHIP CAPACITOR
C17	100 pF ATC 100B SURFACE MOUNT CERAMIC CHIP CAPACITOR
C16, C12, C11, C1	47 pF ATC 100B SURFACE MOUNT CERAMIC CHIP CAPACITOR
C15	10 μF / 50V ALUMINIUM ELECTROLYTIC RADIAL LEAD CAPACITOR
C13	100 pF ATC 700B SURFACE MOUNT CERAMIC CHIP CAPACITOR
C9, C2	0.8-8.0 pF GIGA TRIM VARIABLE CAPACITOR
C8	6.2 pF ATC 100B SURFACE MOUNT CERAMIC CHIP CAPACITOR
C7, C6, C5, C4	10 pF ATC 100B SURFACE MOUNT CERAMIC CHIP CAPACITOR
C3	3 pF ATC 100B SURFACE MOUNT CERAMIC CHIP CAPACITOR
R3	120 0-IM, 2W SURFACE MOUNT CERAMIC CHIP CAPACITOR
R2	4.7 M OHM 1W SURFACE MOUNT CERAMIC CHIP CAPACITOR
R1	18 K OHM, 1W SURFACE MOUNT CERAMIC CHIP CAPACITOR
FB2, FB1	SHIELD BEAD SURFACE MOUNT EMI
L2, L1	INDUCTOR, 5 TURNS AIR WOUND #22AWG, ID=0.059[1.49], NYLON COATED MAGNET WIRE
PCB	WOVEN FIBERGLASS REINFORCED PTFE 0.080" THK, εr=2.55, 2 Oz EDCu BOTH SIDE



TEST CIRCUIT

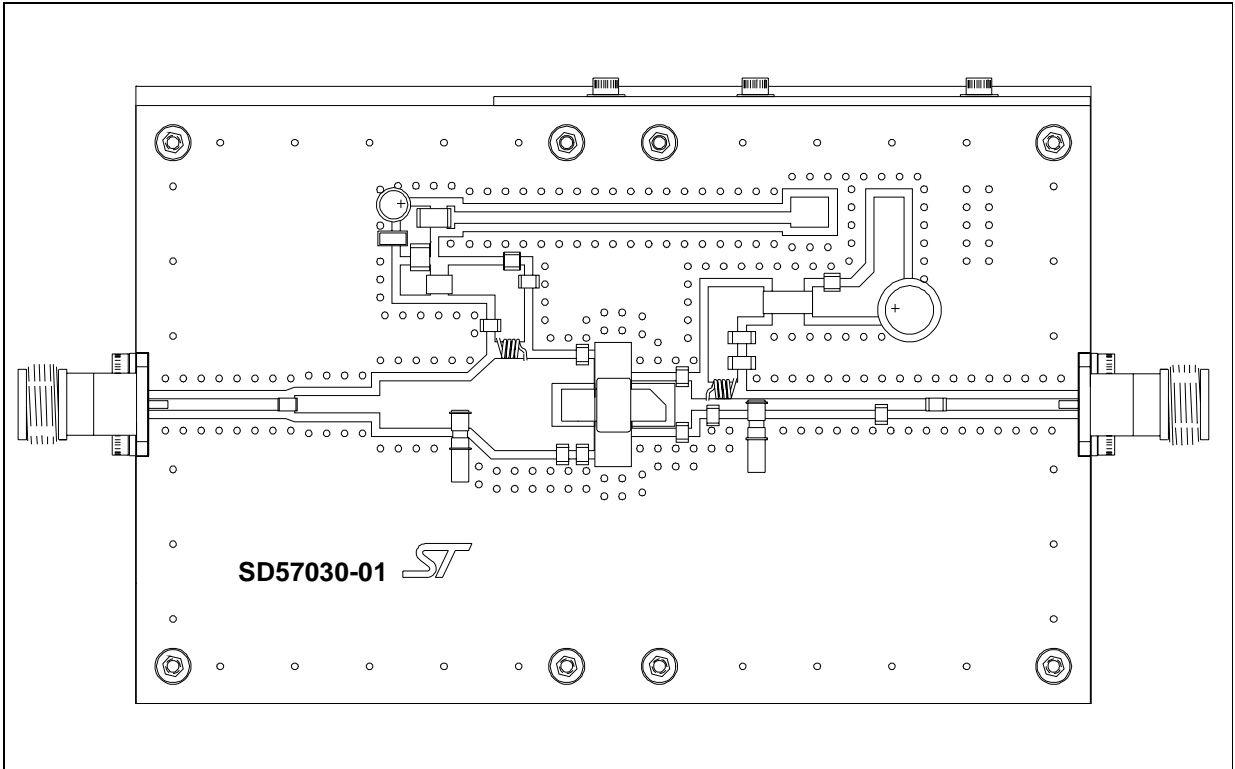

TEST CIRCUIT PHOTOMASTER

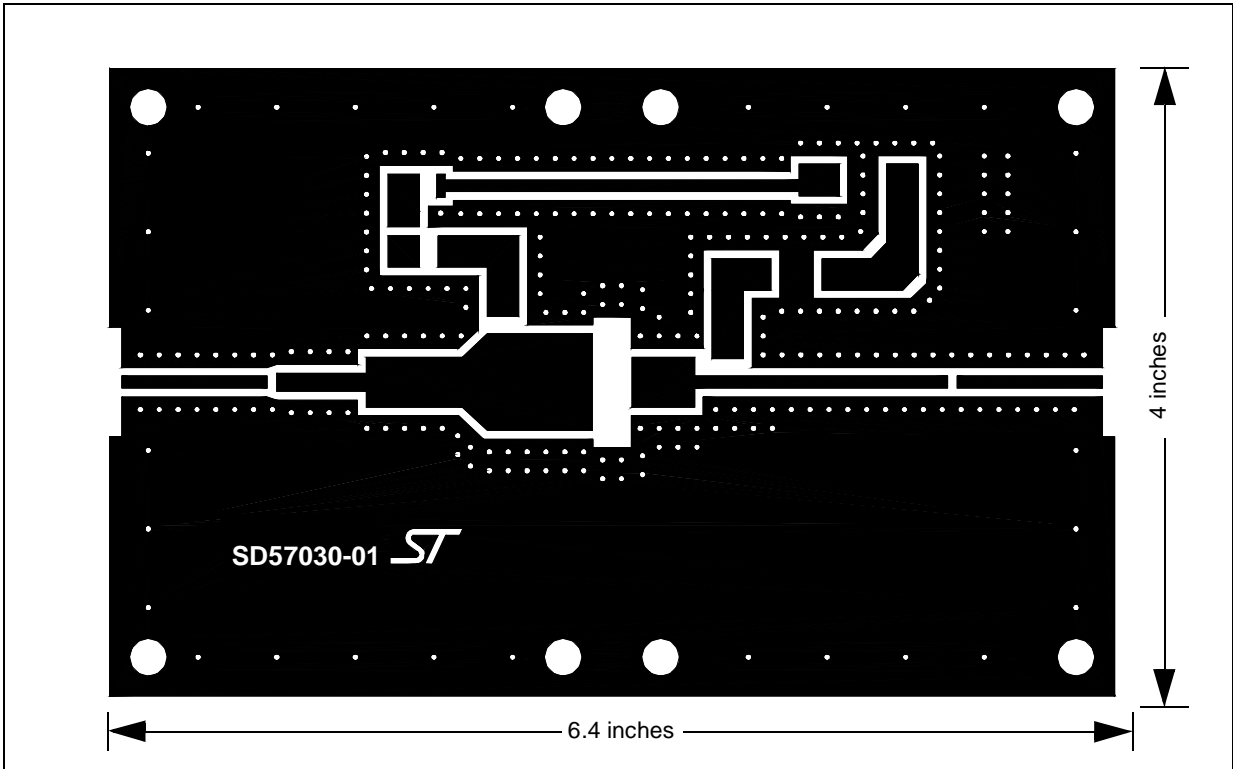

M250 (.230 x .360 2L N/HERM W/FLG) MECHANICAL DATA

DIM.	mm			Inch		
	MIN.	TYP.	MAX	MIN.	TYP.	MAX
A	5.21		5.71	0.205		0.225
B	2.16		2.92	0.085		0.115
C	5.59		6.09	0.220		0.240
D	8.89		9.40	0.350		0.370
E	9.40		9.91	0.370		0.390
F	0.11		0.15	0.004		0.006
G	0.89		1.14	0.035		0.045
H	1.45		1.70	0.057		0.067
I	2.67		3.94	0.105		0.155

