

**PROTECTION PRODUCTS**
**Description**

The SDC36C is a high-surge transient voltage suppressor (TVS) optimized for protection of sensitive digital sensors used in proximity switches and industrial control applications. The SDC36C protects the components from over-voltages caused by electrostatic discharge (ESD), electrical fast transients (EFT), and tertiary lightning. The unique design of the SDC36C incorporates two TVS diodes in a compact package for applications where board space is at a premium. The single package provides protection for the I/O line and power supply rail with high surge capabilities (4 Amps at  $t_p=1.2/50\mu s$ ) and an exceptionally low clamping voltage of  $<47V$ .

The SDC36C replaces up to two large discrete diodes providing the designer an easy to implement integrated solution. The SDC36C is in a 3-pin, RoHS/WEEE compliant, SOT-23 package. The small size and unique features of the SDC36C make it ideal for protection of two, three, and four wire DC high-side proximity switches.

**Features**

- Transient Protection to
  - ♦ IEC 61000-4-2 (ESD): 15kV (Air), 8kV (Contact)
  - ♦ IEC 61000-4-4 (EFT): 40A (5/50ns)
  - ♦ IEC 61000-4-5 (Lightning): 4A (8/20 $\mu s$ )
- Replaces Two Discrete Devices
- Protects Two Lines
- Working Voltage: 33V
- High Surge capability
- Solid-State Silicon-Avalanche Technology

**Mechanical Characteristics**

- JEDEC SOT-23 Package
- Pb-Free, Halogen Free, RoHS/WEEE Compliant
- Molding Compound Flammability Rating: UL 94V-0
- Marking : Marking Code
- Packaging : Tape and Reel

**Applications**

- Two, Three, and Four Wire DC High-Side Proximity Switch
- I/O Link
- Digital Sensor Input Protection
- Industrial Equipment

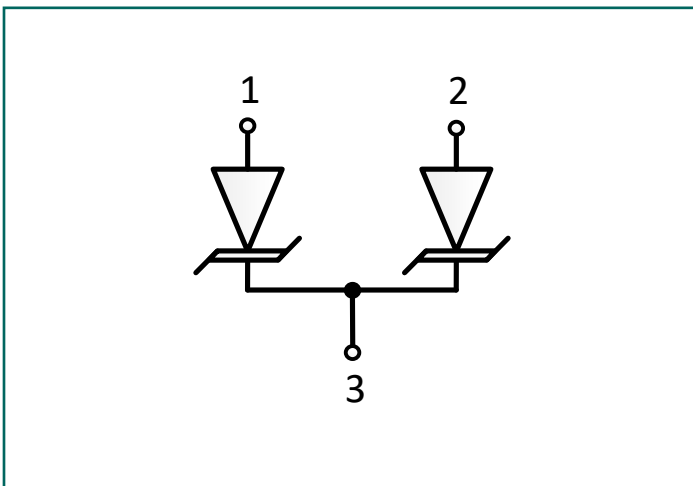
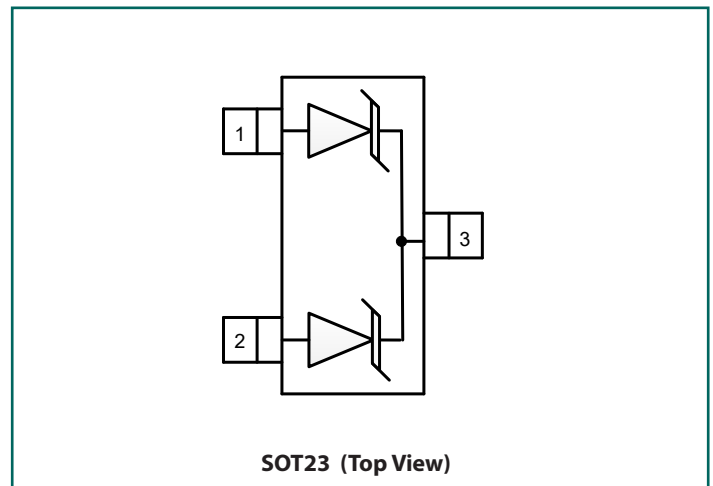
**Circuit Diagram**

**Schematic and Pin Configuration**

## Absolute Maximum Ratings

Rating	Symbol	Value	Units
Peak Pulse Power (tp = 8/20μs)	P <sub>PK</sub>	350	W
Peak Pulse Power (tp = 1.2/50μs)	P <sub>PK</sub>	225	W
Peak Pulse Current (tp = 1.2/50μs)	I <sub>PP</sub>	4	A
Non-Repetitive Peak Forward Current (tp = 100μs)	I <sub>F5MAX</sub>	4	A
Operating Temperature	T <sub>J</sub>	-55to +125	°C
Storage Temperature	T <sub>STG</sub>	-55 to +150	°C

## Electrical Characteristics (T=25°C unless otherwise specified)

Parameter	Symbol	Conditions	Min.	Typ.	Max.	Units
Reverse Stand-Off Voltage	V <sub>RWM</sub>	-40°C to 125°C, Pin 3 to Pin 1 or 2			33	V
Reverse Breakdown Voltage	V <sub>BR</sub>	I <sub>t</sub> = 1mA, Pin 3 to Pin 1 or 2	35			V
Reverse Leakage Current	I <sub>R</sub>	V <sub>RWM</sub> = 33V	T = 25°C		5	μA
			T = 85°C		25	μA
Clamping Voltage	V <sub>C</sub>	I <sub>PP</sub> = 2A, tp = 1.2/50μs			47	V
Forward Voltage	V <sub>F</sub>	I <sub>F</sub> = 100mA			1.3	V
Junction Capacitance	C <sub>J</sub>	V <sub>R</sub> = 0V, f = 1MHz, Pin 3 to Pin 1 or 2			120	pF

### Notes:

- (1): ESD Gun return path to Ground Reference Plane (GRP)
- (2): Transmission Line Pulse Test (TLP) Settings: tp = 100ns, tr = 0.2ns, I<sub>TLP</sub> and V<sub>TLP</sub> averaging window: t<sub>1</sub> = 70ns to t<sub>2</sub> = 90ns.
- (3): Dynamic resistance calculated from I<sub>TLP</sub> = 4A to I<sub>TLP</sub> = 16A.

# Typical Characteristics

### Non-Repetitive Peak Pulse Power vs. Pulse Time

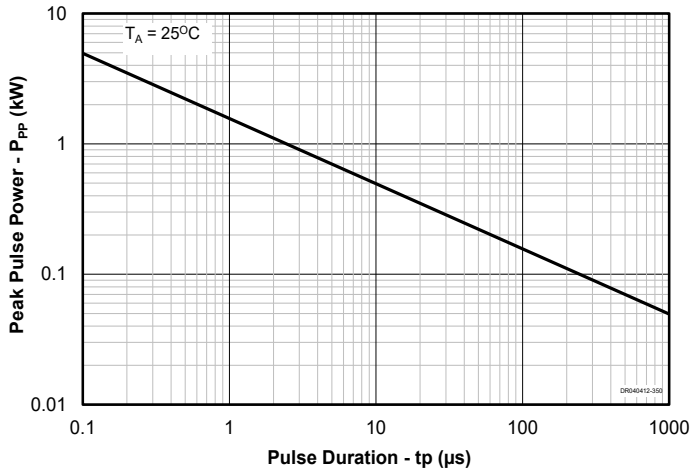

### Power Derating Curve

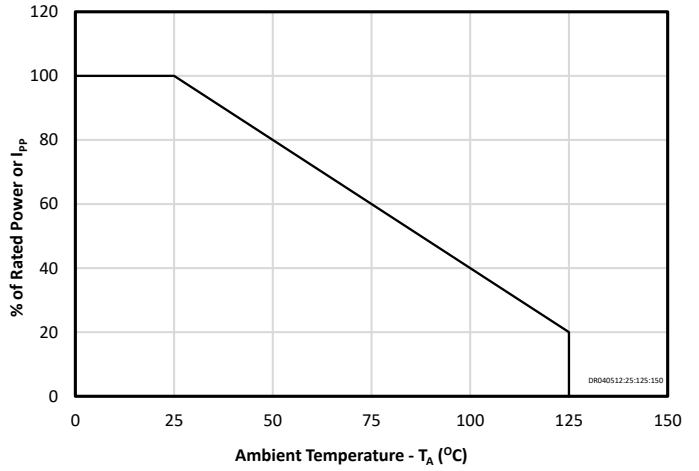

### Pulse Waveform

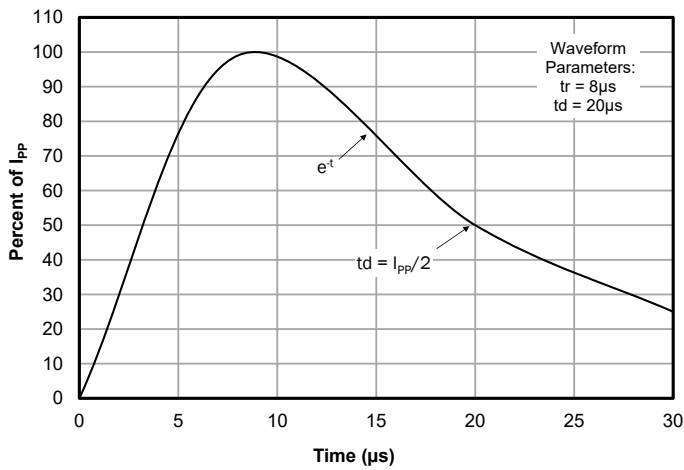

### Clamping Voltage vs. Peak Pulse Current (8/20 $\mu$ s Pulse)

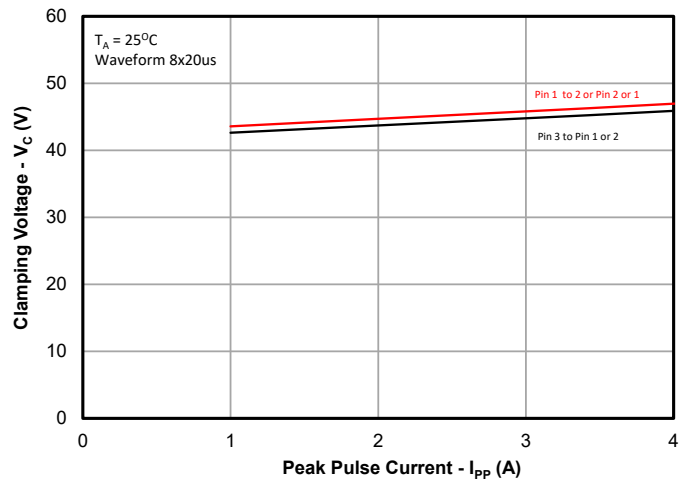

### Forward Voltage vs. Peak Pulse Current (8/20 $\mu$ s Pulse)

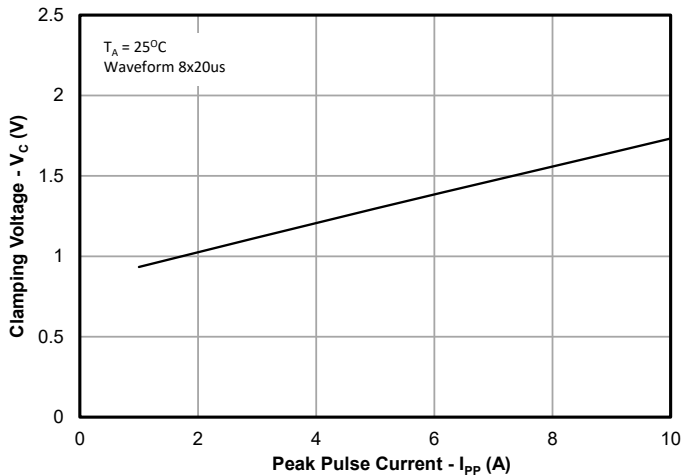

# Application Information

## Device Connection for Protection of Two, Three, and Four Wire Proximity Switches

Digital sensors help to bridge the gap between the physical world and the digital world in applications such as computer controlled factory automation. In such environments, transient voltages can easily disrupt or damage sensitive sensor inputs. The SDC36C provides transient voltage protection for the digital sensors to ensure their operation is not disrupted by the physical world.

The SDC36C is designed to meet the high surge capability and low clamping voltage needed to protect the ASIC and control logic used in proximity switches. The SDC36C provides protection for the power and I/O lines. Typical configurations for the protection of two, three, and four wire switches are as follows:

- 1. Two-Wire Switch:** Connect pin 1 to the I/O line and pin 2 to the DC supply (since the device is symmetrical, these connections can be reversed). Pin 3 is not connected.
- 2. Three-Wire Switch:** Either pin 1 or pin 2 is connected to the I/O line with the other connected to ground. Pin 3 must be connected to the DC supply.
- 3. Four-Wire Switch:** Two devices are required to protect four wire switches. Pin 3 of each device is connected to the DC supply line. Pins 1 and 2 are connected to the I/O lines and ground as shown.

### Matte Tin Lead Finish

Matte tin has become the industry standard lead-free replacement for SnPb lead finishes. A matte tin finish is composed of 100% tin solder with large grains. Since the solder volume on the leads is small compared to the solder paste volume that is placed on the land pattern of the PCB, the reflow profile will be determined by the requirements of the solder paste. Therefore, these devices are compatible with both lead-free and SnPb assembly techniques. In addition, unlike other lead-free compositions, matte tin does not have any added alloys that can cause degradation of the solder joint.

### 2-Wire DC Proximity Switch Application

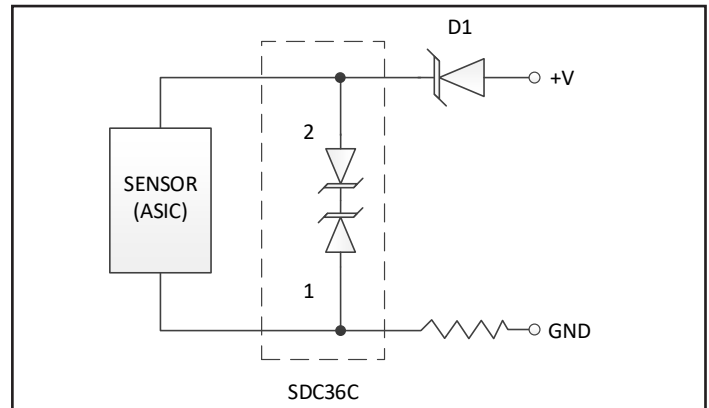

### 3-Wire DC Proximity Switch Application

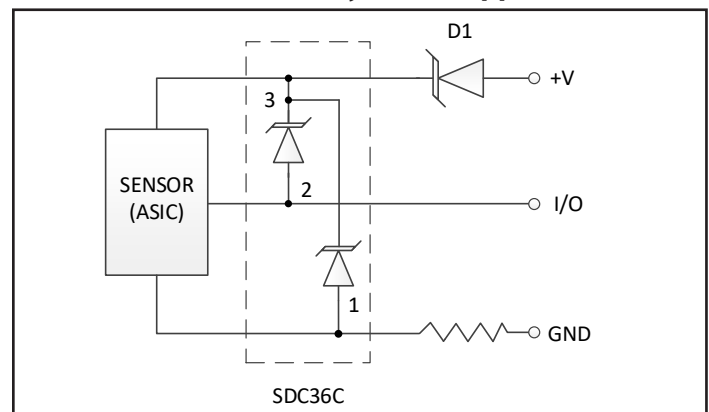

### 4-Wire DC Proximity Switch Application

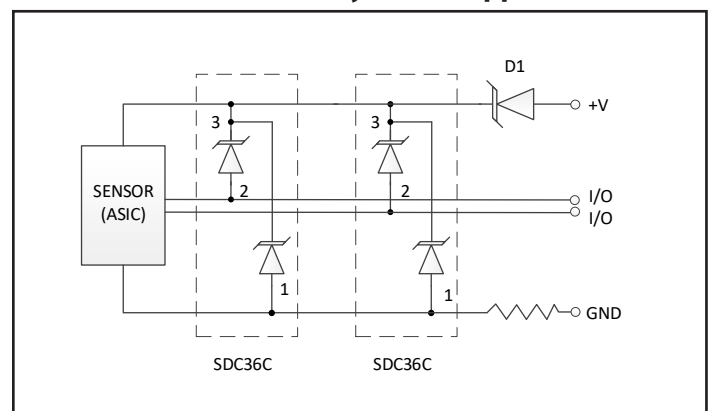

# Outline Drawing - SOT23-3L

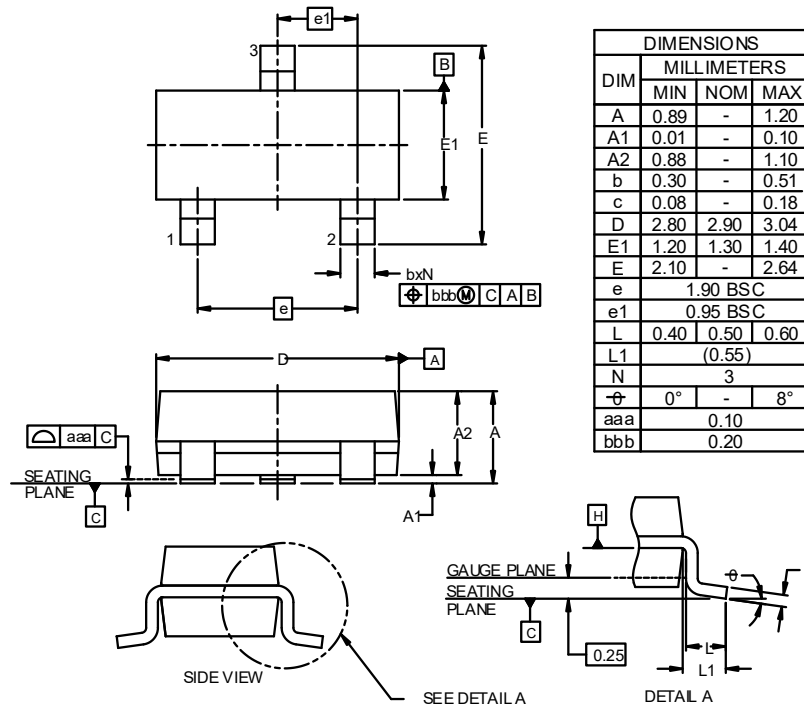

DIMENSIONS			
DIM	MILLIMETERS		
	MIN	NOM	MAX
A	0.89	-	1.20
A1	0.01	-	0.10
A2	0.88	-	1.10
b	0.30	-	0.51
c	0.08	-	0.18
D	2.80	2.90	3.04
E1	1.20	1.30	1.40
E	2.10	-	2.64
e	1.90 BSC		
e1	0.95 BSC		
L	0.40	0.50	0.60
L1	(0.55)		
N	3		
$\theta$	0°	-	8°
aaa	0.10		
bbb	0.20		

- NOTES:
1. CONTROLLING DIMENSIONS ARE IN MILLIMETERS (ANGLES IN DEGREES).
  2. DATUMS  $-A$  AND  $-B$  TO BE DETERMINED AT DATUM PLANE  $-H$
  3. DIMENSIONS "E1" AND "D" DO NOT INCLUDE MOLD FLASH, PROTRUSIONS OR GATE BURRS.

# Land Pattern - SOT23-3L

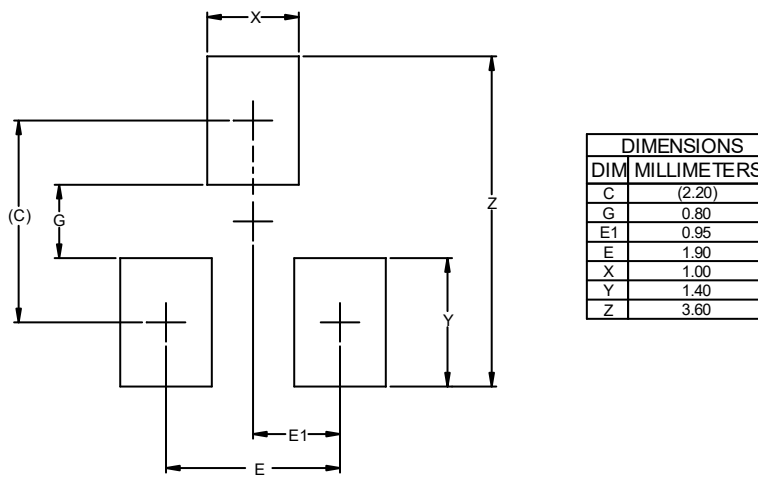

DIMENSIONS	
DIM	MILLIMETERS
C	(2.20)
G	0.80
E1	0.95
E	1.90
X	1.00
Y	1.40
Z	3.60

- NOTES:
1. CONTROLLING DIMENSIONS ARE IN MILLIMETERS (ANGLES IN DEGREES).
  2. THIS LAND PATTERN IS FOR REFERENCE PURPOSES ONLY CONSULT YOUR MANUFACTURING GROUP TO ENSURE YOUR COMPANY'S MANUFACTURING GUIDELINES ARE MET.
  3. REFERENCE IPC-SM-782A.

## Marking Code

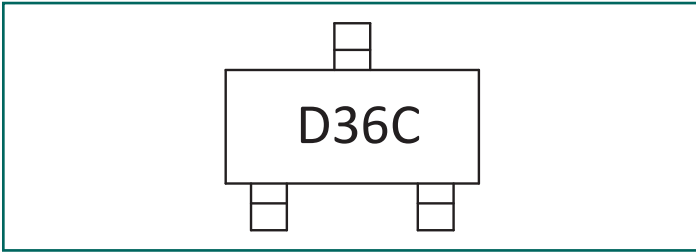

## Tape and Reel Specification

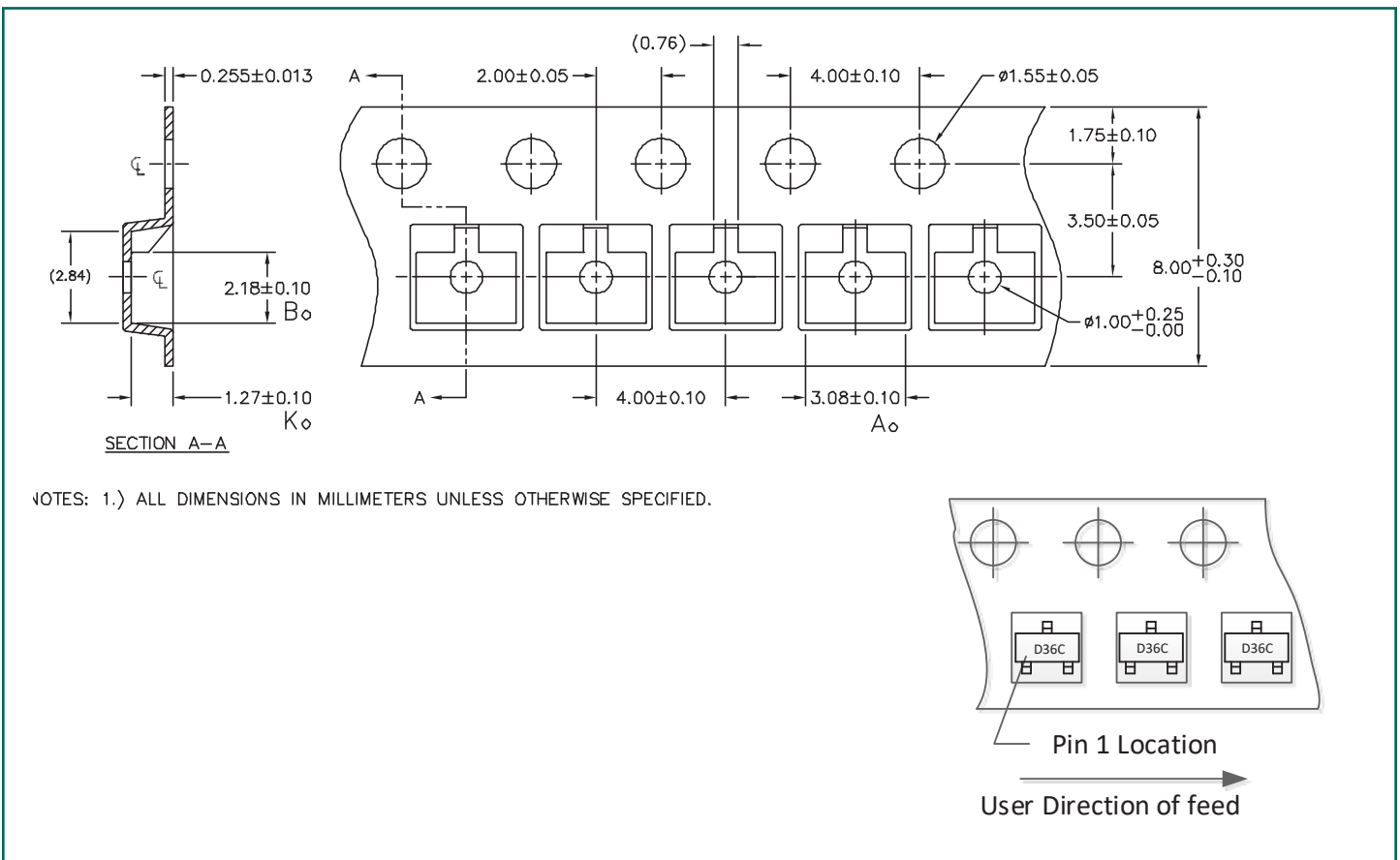

## Ordering Information

Part Number	Qty per Reel	Reel Size	Pitch
SDC36C.TCT	3000	7 Inch	4mm