



TAOGLAS®



Datasheet

Part No:

SDCP.5900.12.4.A.40

Description:

SDCP.5900 5.9GHz C-V2X Circular Polarized Embedded SMD 12*12*4mm Patch Antenna

Features:

5.9GHz C-V2X Ceramic Patch Antenna

5850MHz to 5925MHz

Peak Gain: 4.64dBi

Efficiency: 60%

Dimensions: 12*12*4mm

IATF16949 Production & Quality Approved

RoHS & REACH Compliant

1.	Introduction	3
2.	Specifications	4
3.	Antenna Characteristics	5
4.	Radiation Patterns	10
5.	Mechanical Drawing - Antenna	12
6.	Footprint	13
7.	Antenna Integration Guide	14
8.	Mechanical Drawing – Evaluation Board	19
9.	Soldering Conditions	20
10.	Packaging	21
	Changelog	23

Taoglas makes no warranties based on the accuracy or completeness of the contents of this document and reserves the right to make changes to specifications and product descriptions at any time without notice. Taoglas reserves all rights to this document and the information contained herein. Reproduction, use or disclosure to third parties without express permission is strictly prohibited.



1. Introduction



The SDCP.5900.12.4.A.40 is a 12*12*4mm embedded ceramic C-V2X (& DSRC) Patch antenna. It is a high-performance directional antenna designed to operate at 5.9GHz for V2V / V2X / V2I systems. The directionality of the antenna allows further range of C-V2X communications. For example, one patch can be mounted to the front of the vehicle, and one to back. Its tiny size allows placement in crowded vehicle interiors. The SMD mounting is particularly suited to high volume manufacturing applications.

Typical Applications:

- Automotive Rearview Mirror Back Mount
- In-Vehicle Window Mount
- Embedded in Roadside Transceivers

C-V2X is the communications medium of choice for active safety V2V/V2X (Vehicle-to-Vehicle and Vehicle-to-Other) systems. Primarily allocated for vehicle safety applications, C-V2X supports high-speed, low-latency, short-range, V2V/V2X wireless communications.

The SDCP.5900 patch antenna has been designed to be circularly polarized to enable a more stable system signal strength typically required on moving vehicles. Circular polarization limits any potential drop in signal from orientation change to 3dB compared to a potential drop of 40dB or more for linear solutions. It results in a system that will maintain the communication link much more reliably.

For further optimization to customer-specific device environments and for support to integrate and test this antennas performance in your device, contact your regional Taoglas customer support team.

2. Specifications

Antenna	
Frequency (MHz)	5850~5925MHz
Efficiency	60.45 %
Peak Gain	4.64 dBi
Average Gain	-2.15 dBi
VSWR	< 2
Polarization	RHCP
Axial Ratio	< 4
Impedance (Ω)	50 Ohms
Mechanical	
Dimensions (mm)	12 x 12 x 4
Weight	2.0g
Mechanical	
Temperature Range	-40°C to 85°C
Humidity	Non-condensing 65°C 95% RH
Moisture Sensitivity Level (MSL)	3 (168 Hours)

3. Antenna Characteristics

3.1 Return Loss

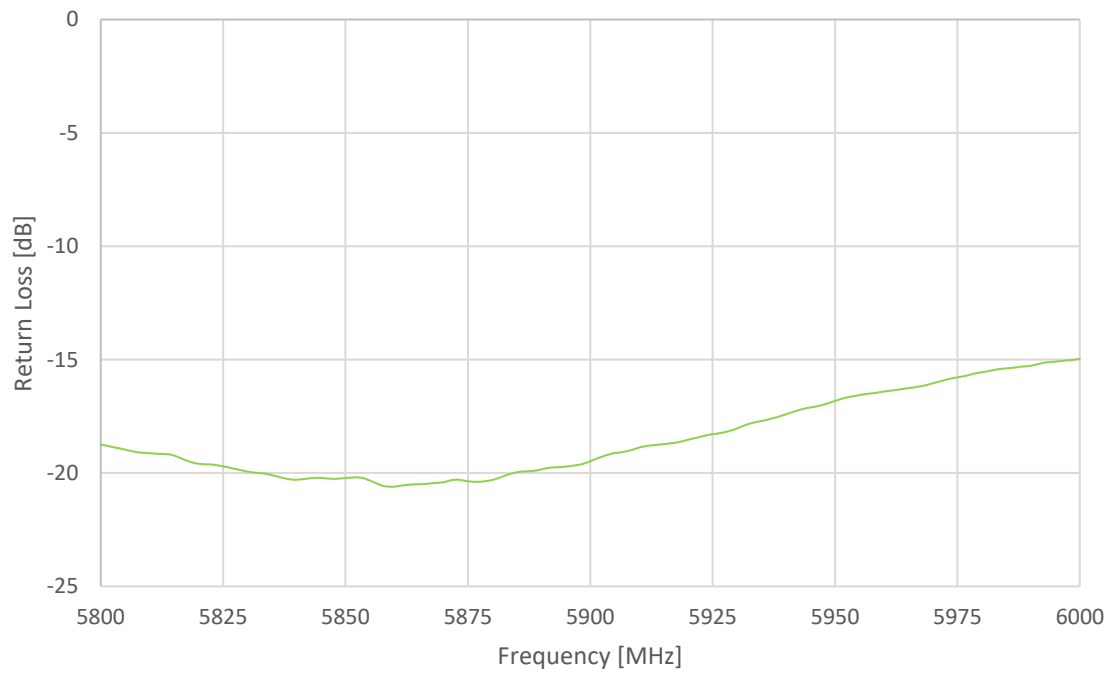

3.2 VSWR

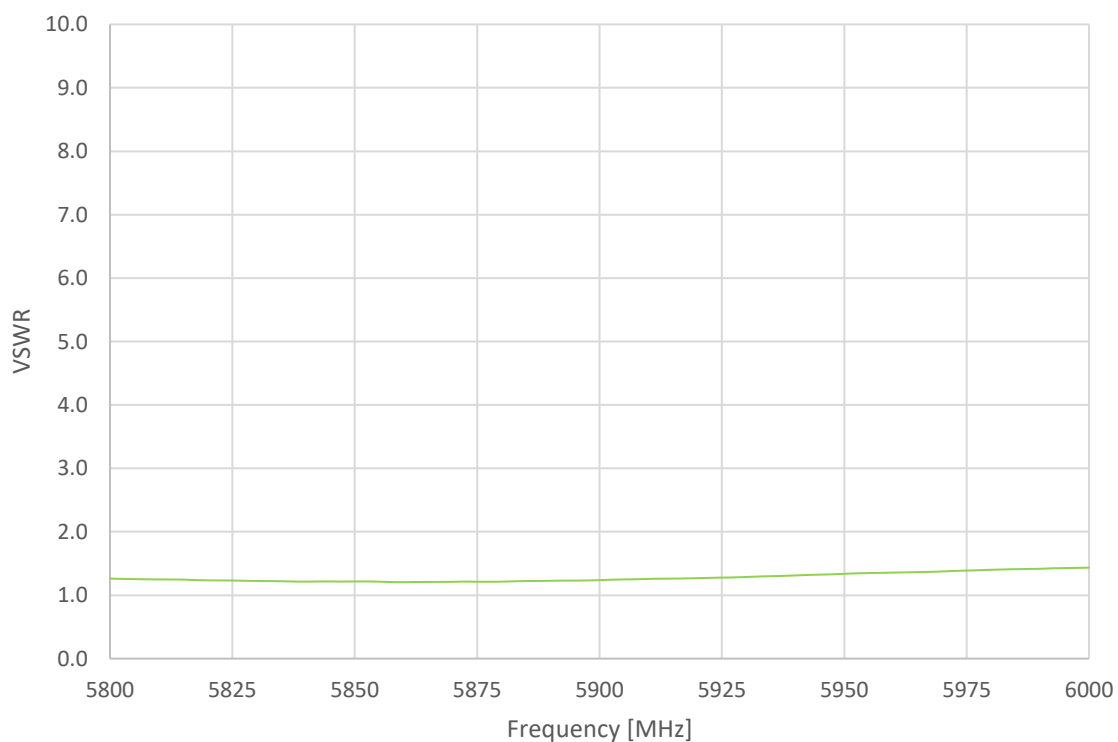

3.3 Efficiency

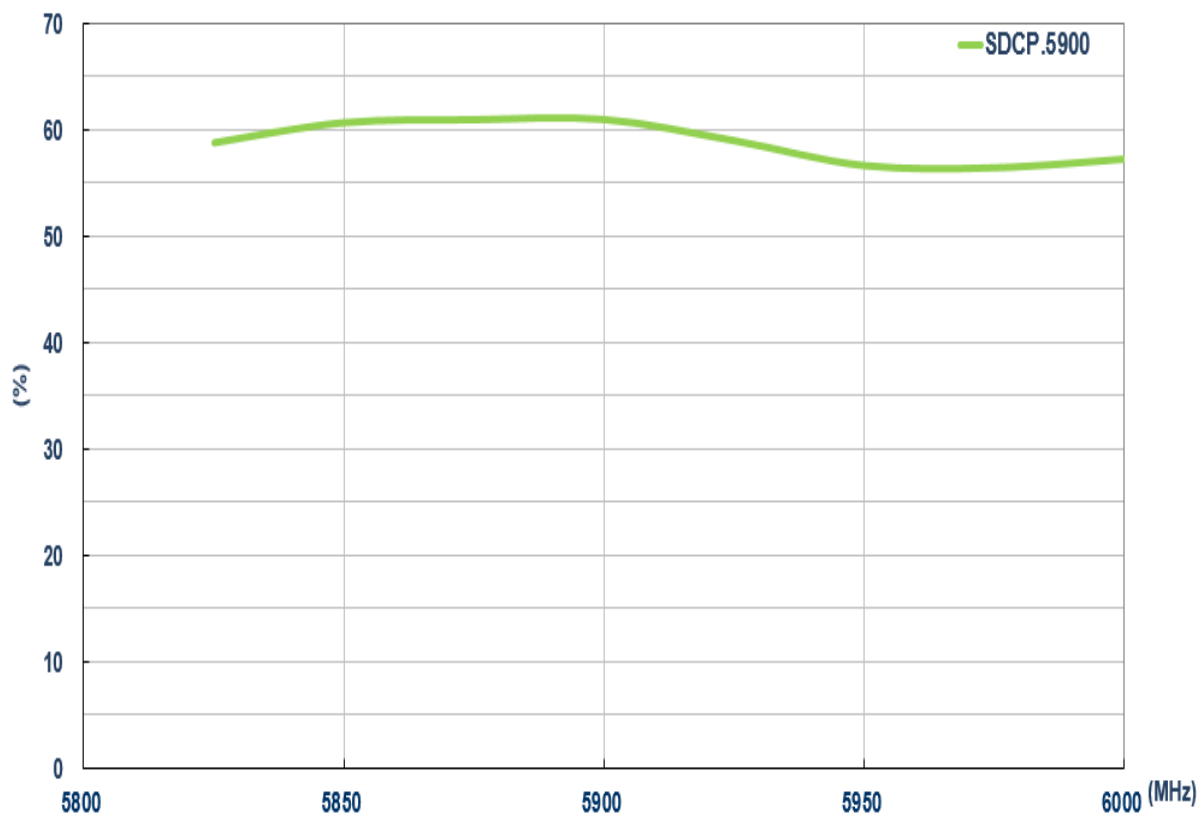

3.4 Peak Gain

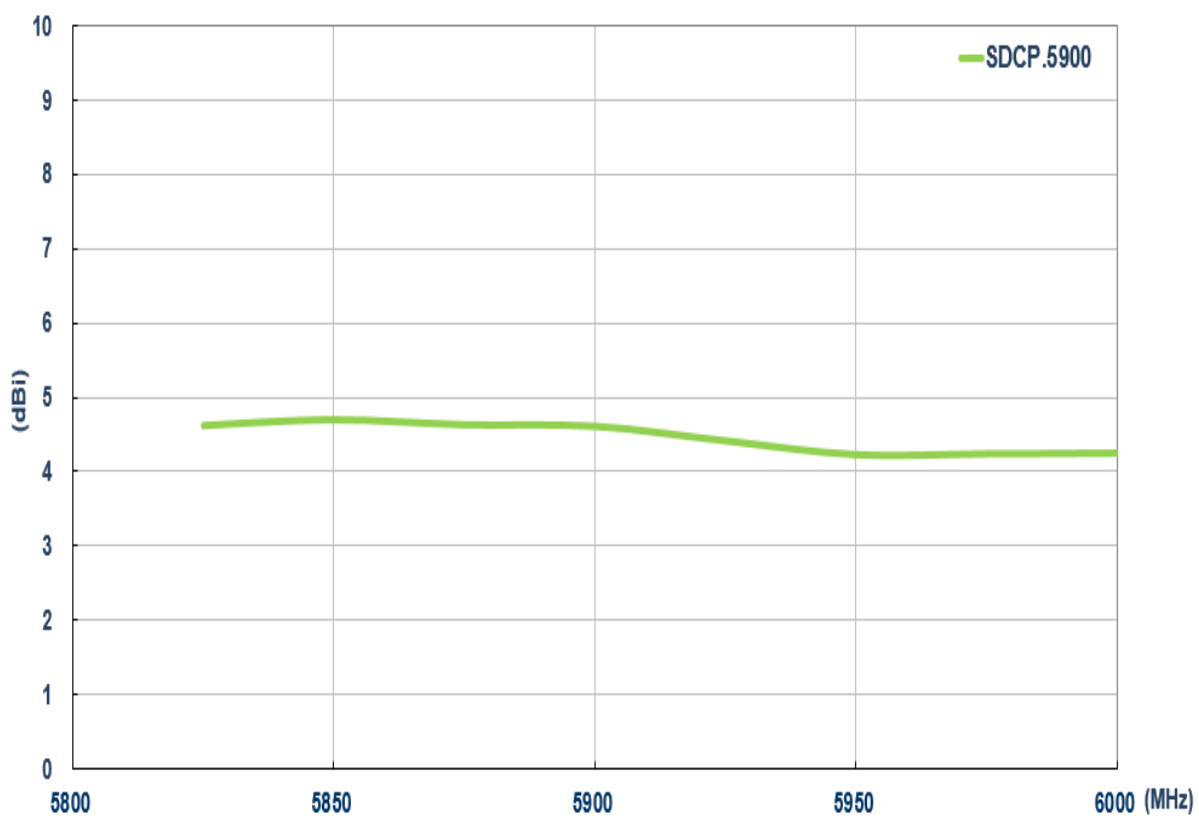

3.5 Average Gain

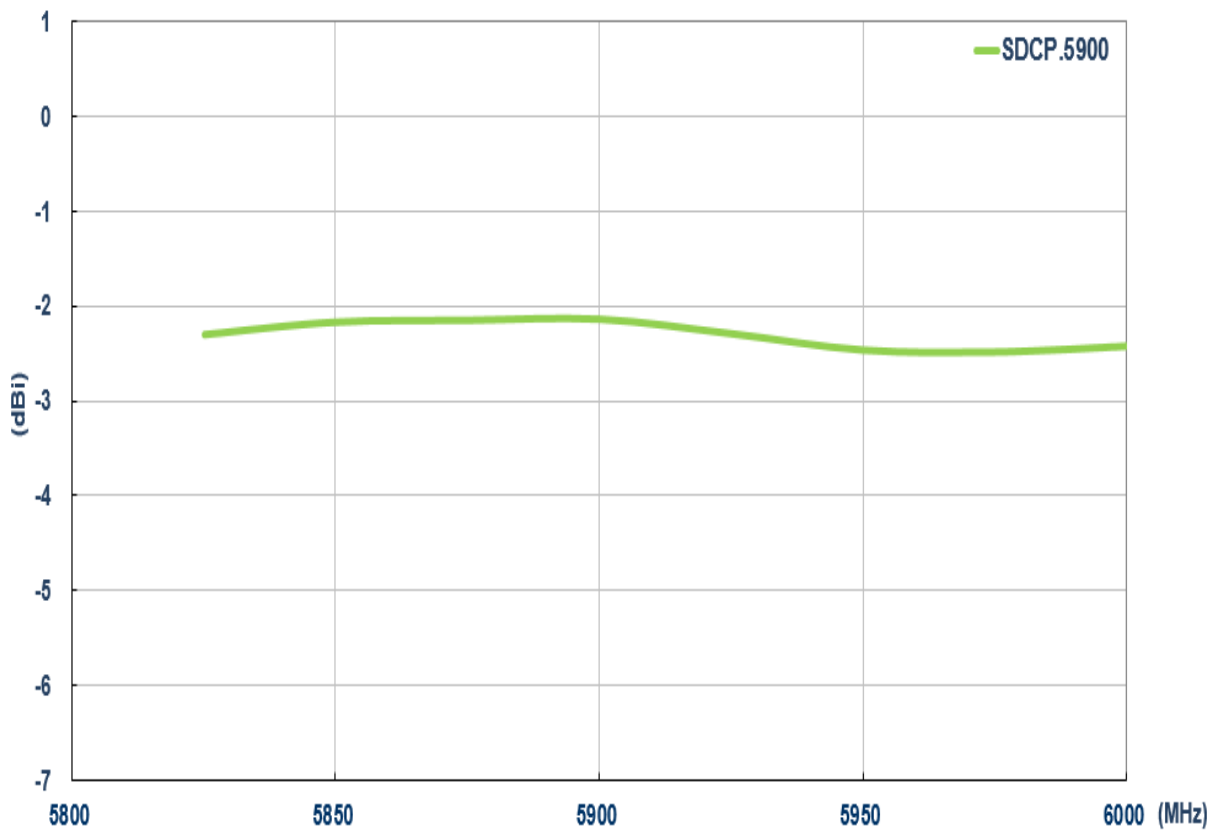

3.6 Axial Ratio: XZ Plane

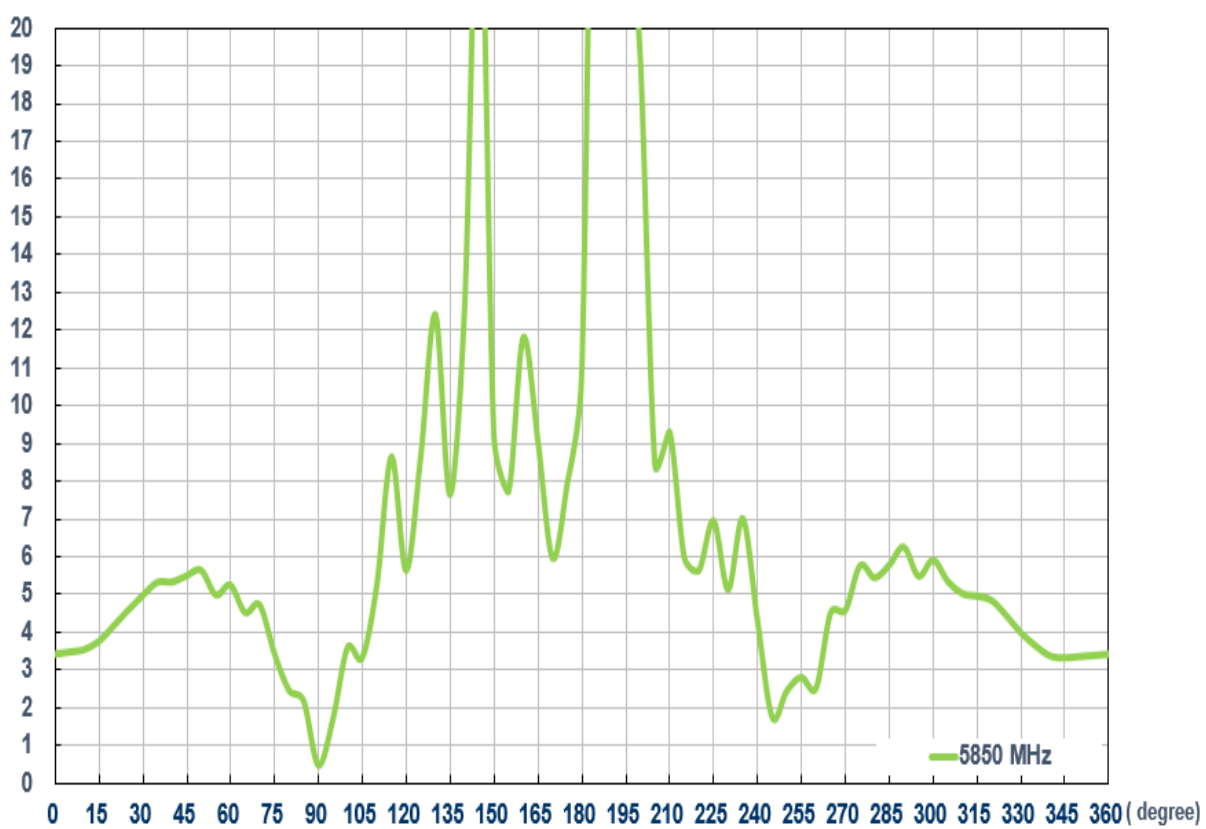

3.7 Axial Ratio: XZ Plane

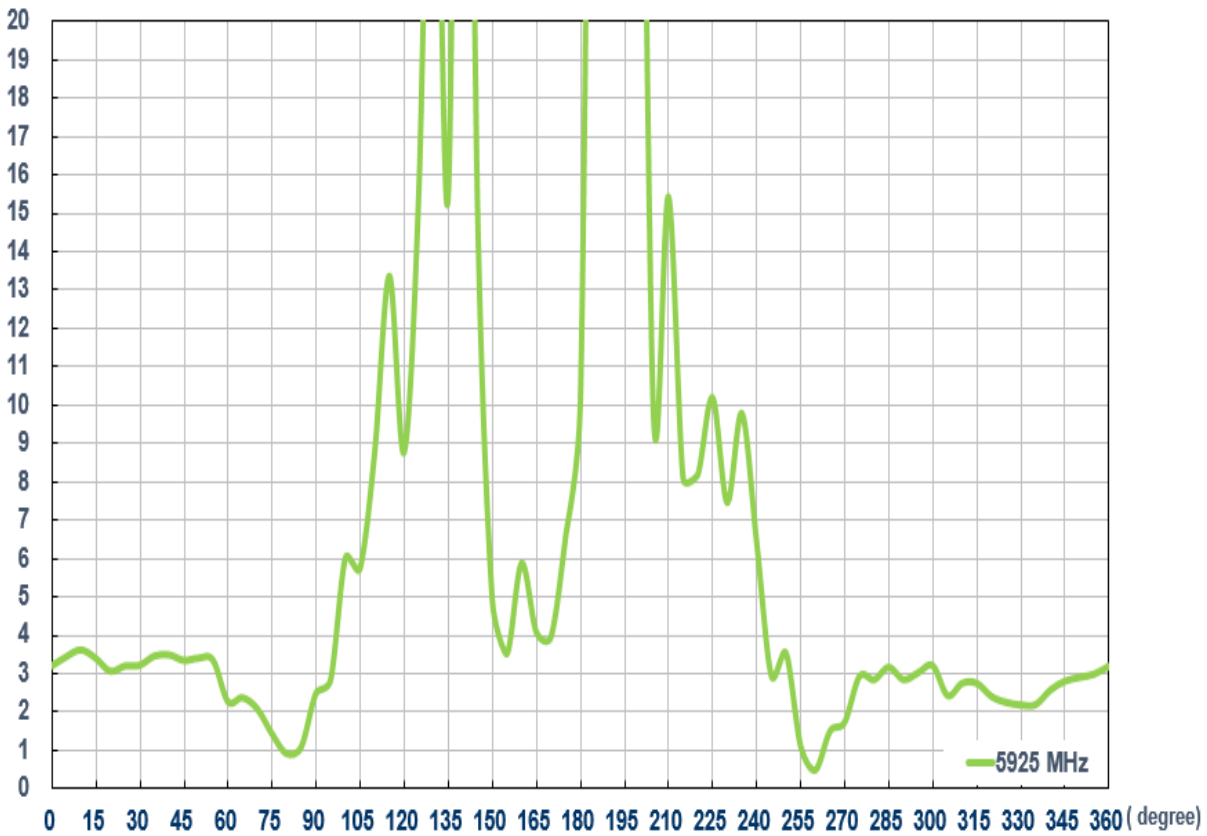

3.8 Axial Ratio: YZ Plane

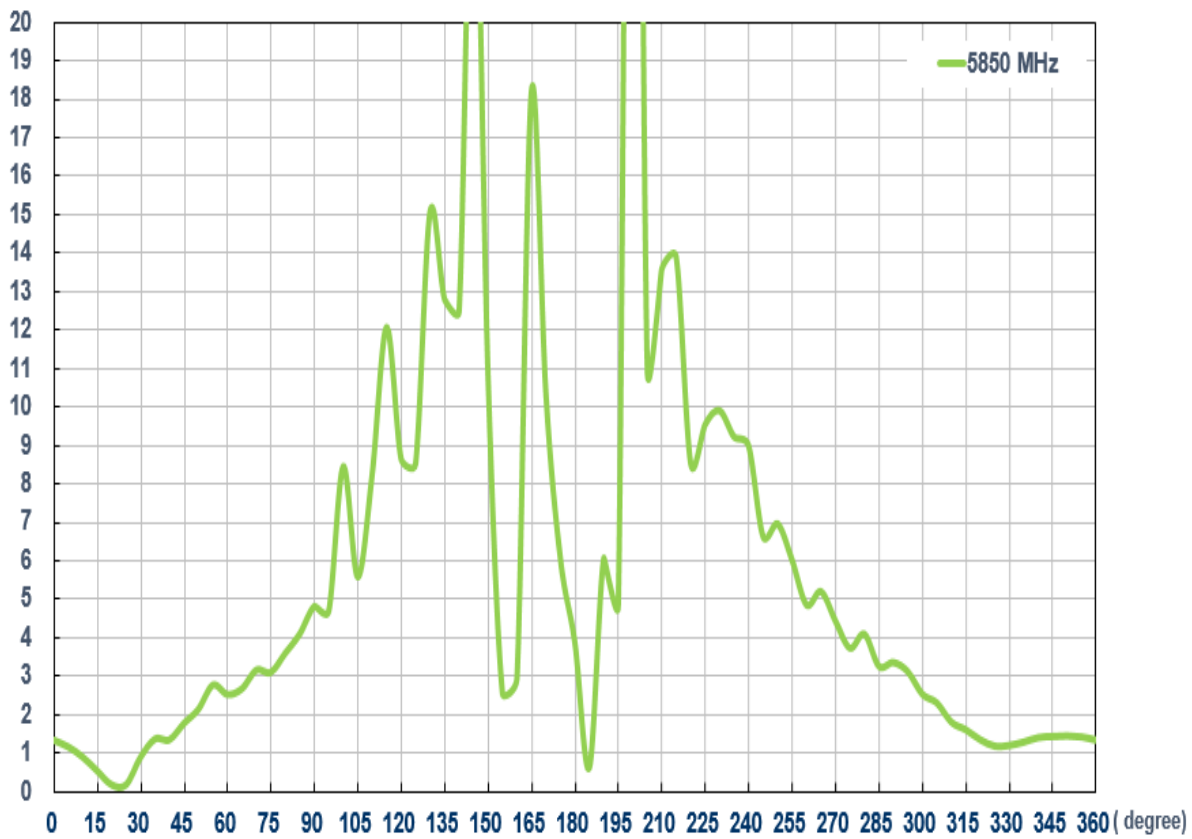

3.9 Axial Ratio: YZ Plane

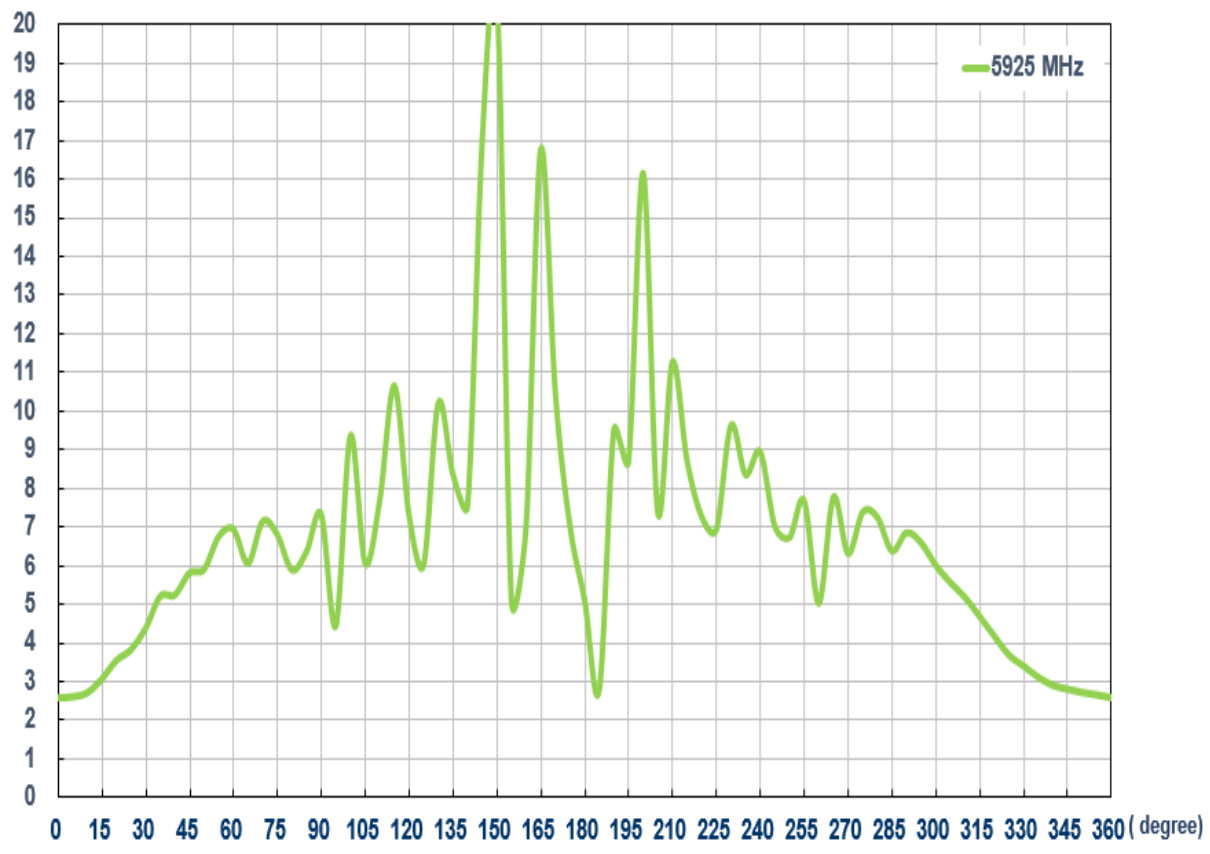

4. Radiation Patterns

4.1 Antenna Setup (Antenna testing Setup in ETS Anechoic Chamber)

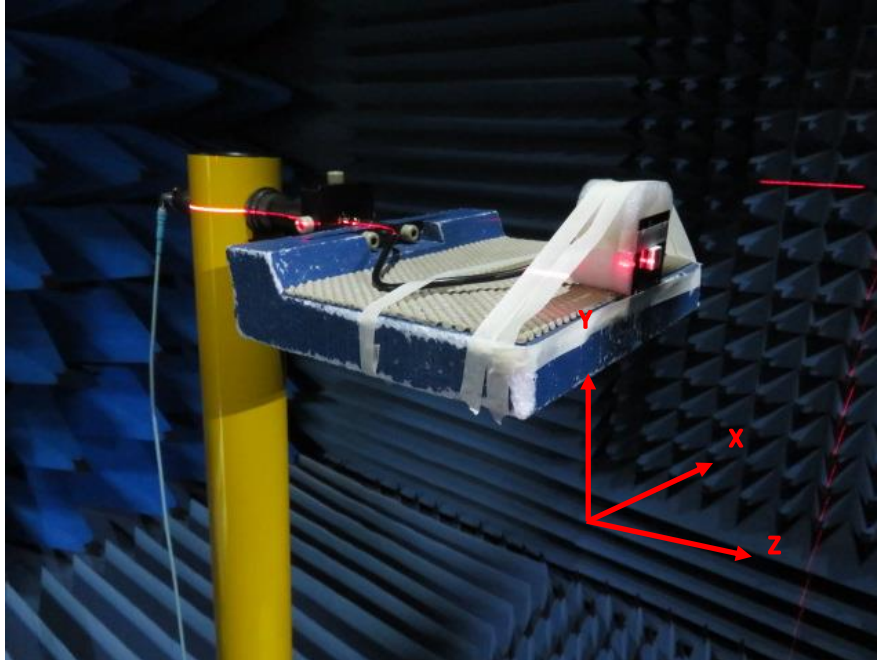

4.2 Radiation Patterns

XY Plane

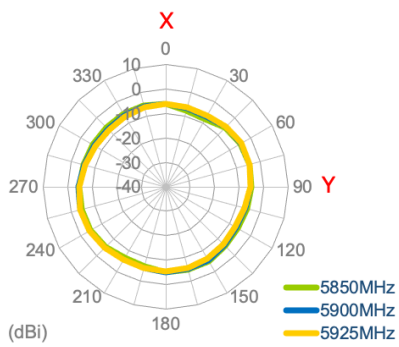

XY Plane Flipped

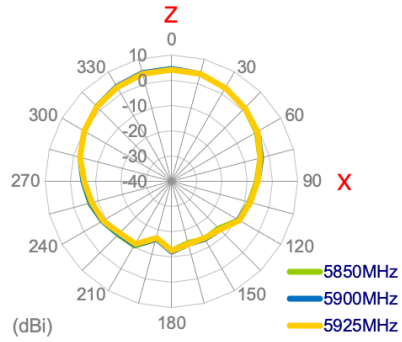

XZ Plane

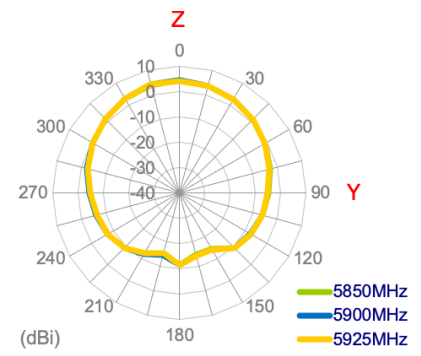

4.3 Antenna 3D Radiation Pattern (In free space)

5850MHz

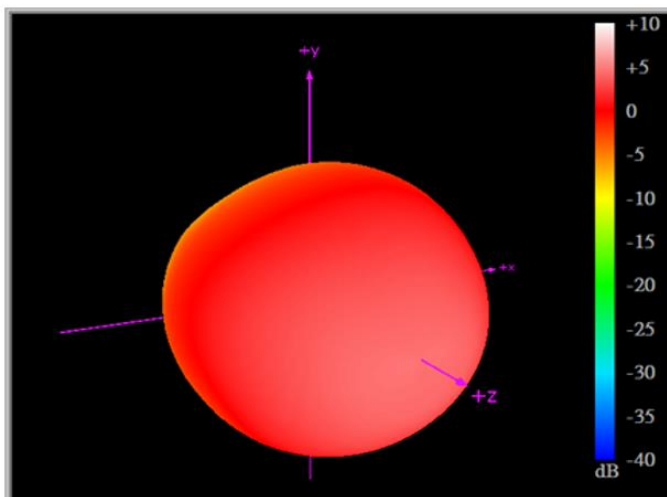

5925MHz

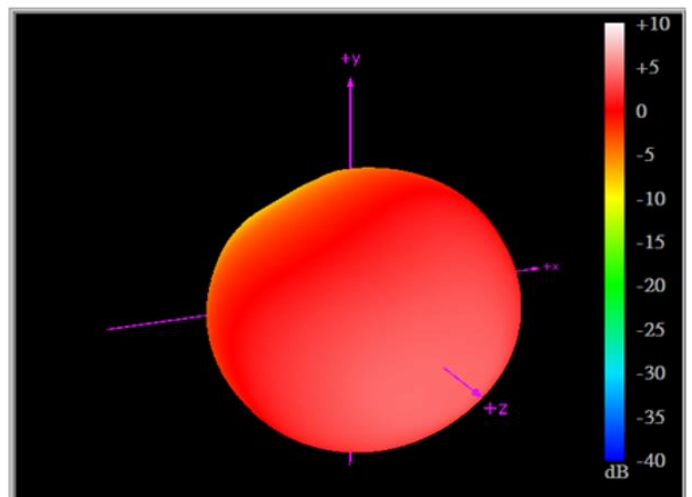

5. Mechanical Drawing - Antenna

5.1 Antenna Main Body

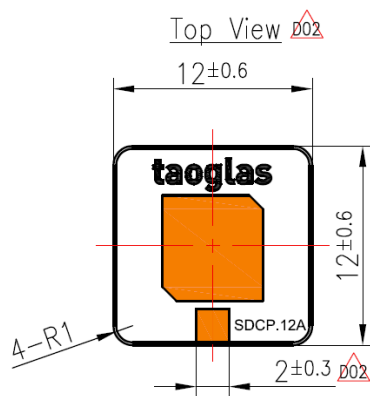

SCALE: 1/1

Side View



Bottom View

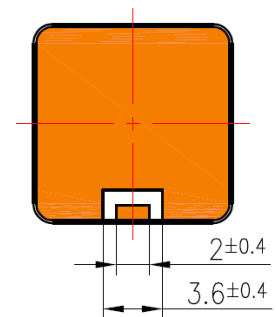

6. Footprint

6.1 Solder Land Pattern

Foot Print																
<p>Top Copper</p> <p>Pads 1, 2, 3, 4, 5, 6, 7 and 9 are the same size. They should be connected to GND.</p> <p>Connected to 50 ohm transmission line.</p>	<p>Top Solder Paste</p> <p>Pads 1, 2, 3, 4, 5, 6, 7 and 9 are the same size.</p>															
<p>Top Solder Mask</p> <p>Pads 1, 2, 3, 4, 5, 6, 7 and 9 are the same size. This drawing is a negative of solder mask. Black regions are anti-mask.</p>	<p>Composite Diagram</p>															
<p>NOTE:</p> <table border="0"> <tr> <td>1. Ag Plated area</td> <td></td> <td>6. Copper keepout should extend through all PCB layers.</td> </tr> <tr> <td>2. Solder Mask area</td> <td></td> <td>7. Any vias in pads should be either filled or tented to prevent solder from wicking away from the pad during reflow.</td> </tr> <tr> <td>3. Copper area</td> <td></td> <td>8. The dimension tolerances should follow standard PCB manufacturing guidelines</td> </tr> <tr> <td>4. Paste area</td> <td></td> <td></td> </tr> <tr> <td>5. Copper Keepout Area</td> <td></td> <td></td> </tr> </table>		1. Ag Plated area		6. Copper keepout should extend through all PCB layers.	2. Solder Mask area		7. Any vias in pads should be either filled or tented to prevent solder from wicking away from the pad during reflow.	3. Copper area		8. The dimension tolerances should follow standard PCB manufacturing guidelines	4. Paste area			5. Copper Keepout Area		
1. Ag Plated area		6. Copper keepout should extend through all PCB layers.														
2. Solder Mask area		7. Any vias in pads should be either filled or tented to prevent solder from wicking away from the pad during reflow.														
3. Copper area		8. The dimension tolerances should follow standard PCB manufacturing guidelines														
4. Paste area																
5. Copper Keepout Area																

7. Antenna Integration Guide



7.1 Schematic Symbol and Pin Definition

The circuit symbol for the antenna is shown below. The antenna has 9 pins as indicated below.

Pin	Description
1	RF Feed
2, 3, 4, 5, 6, 7, 8, 9	Ground

SDCP.5900.12.4.A40
ANT1

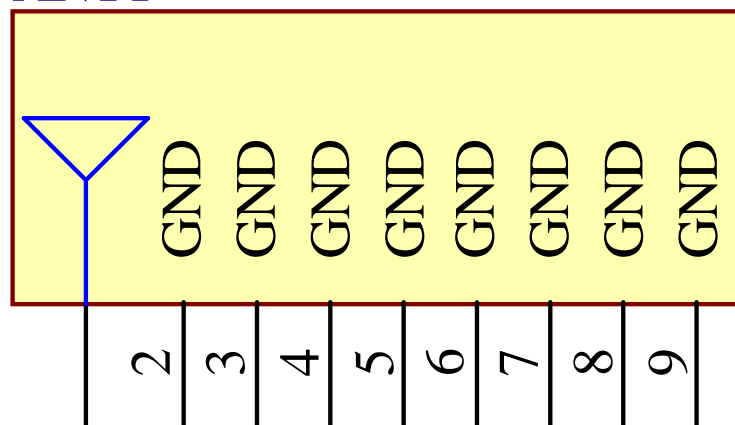

7.2 Antenna Integration

The antenna should be placed at the center of the ground plane with a length and width of 50mm. Maintaining a square symmetric ground plane shape and symmetric environment around the antenna is critical to maintaining the excellent axial ratio and phase center performance shown in this datasheet.



Top Side w/ Solder Mask

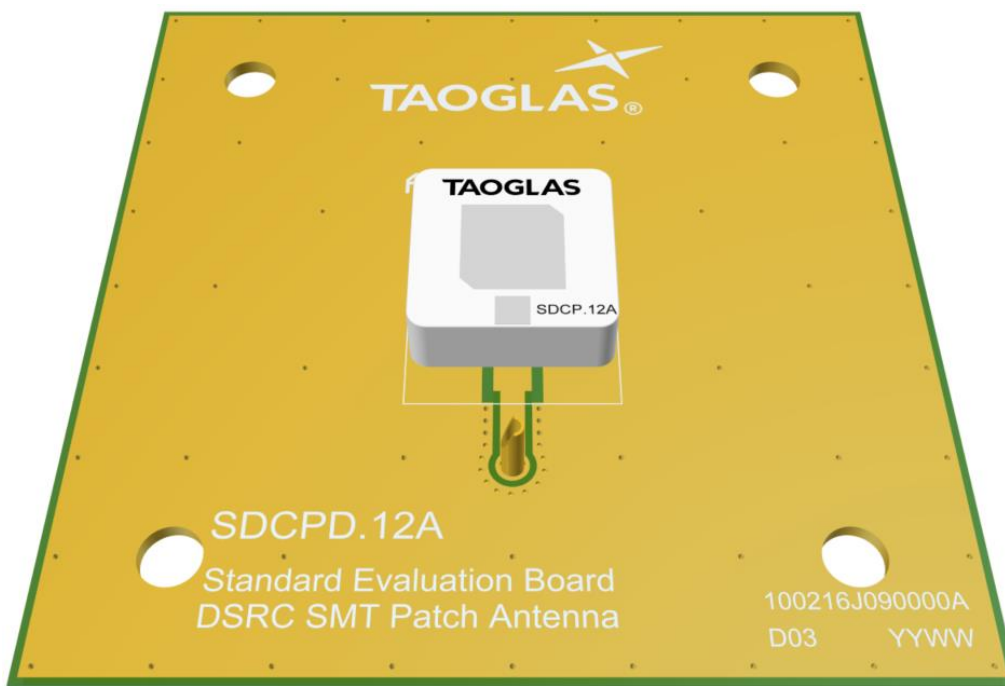

Top Side w/o Solder Mask

7.3 PCB Layout

The footprint and clearance on the PCB must comply with the antenna specification. The PCB layout shown in the diagram below demonstrates the antenna footprint.



Topside

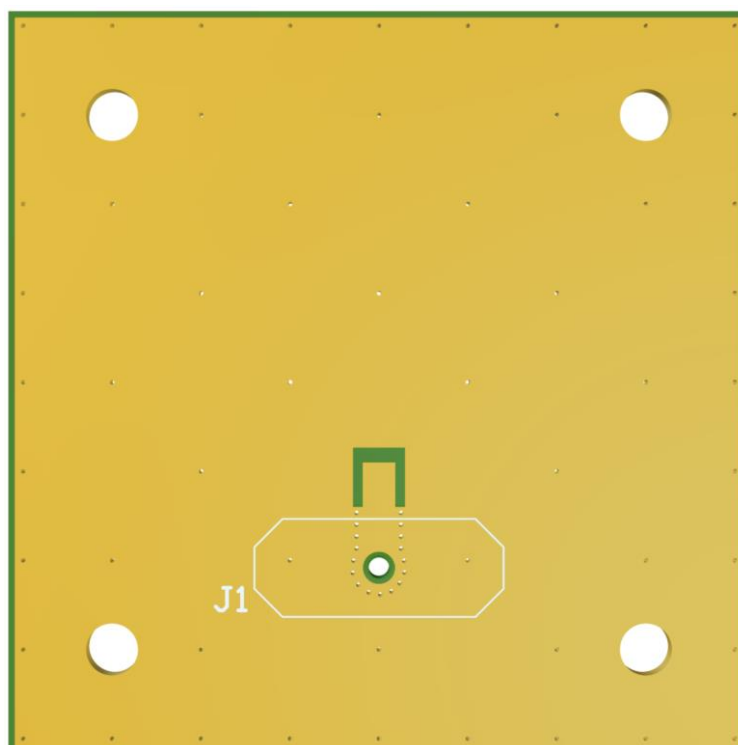

Bottom Side

7.4 Evaluation Board



Topside

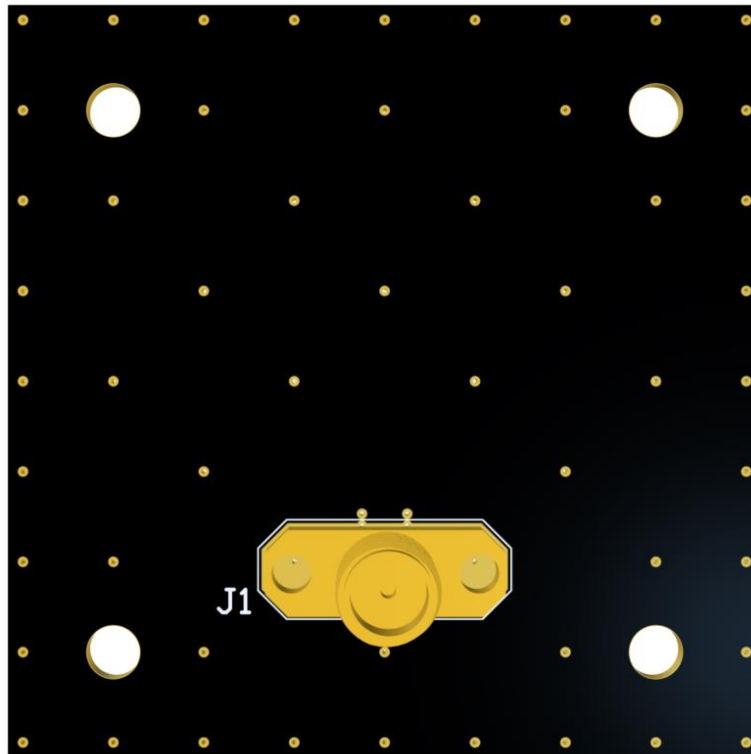

Bottom Side

8. Mechanical Drawing – Evaluation Board

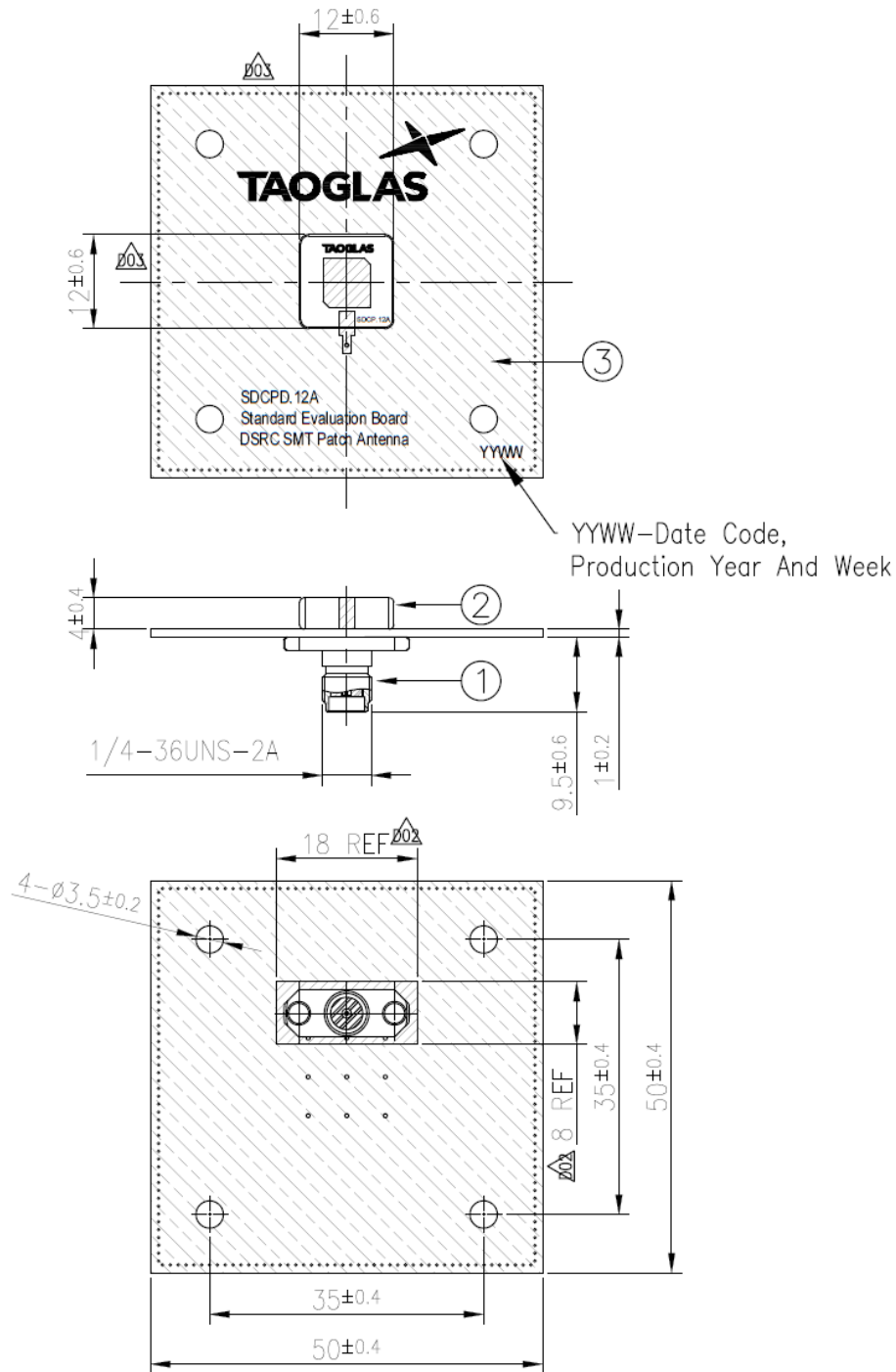

Note:

- 1. Silver Area
- 2. Soldermask Area
- 3. Logo & Text Ink Printing : White

	Name	P/N	Material	Finish	QTY
1	PCB SMA(F)ST $\varnothing 0.3$	001516J000000A	Brass	Au Plated	1
2	SDCP.12A Patch(12x12x4mm)	001516J000000A	Ceramic	Clear	1
3	SDCPD.12A PCB	100216J090000A	Composite 1.0t	Black	1

9. Soldering Conditions

SDCP.5900.12A can be assembled following Pb-free assembly. According to the Standard IPC/JEDEC J-STD-020C, the temperature profile suggested is as follows:

Phase	Profile Features	Pb-Free Assembly (SnAgCu)
PREHEAT	Temperature Min(T_{smin}) Temperature Max(T_{smax}) Time(t_s) from (T_{smin} to T_{smax})	150°C 200°C 60-120 seconds
RAMP-UP	Avg. Ramp-up Rate (T_{smax} to TP)	3°C/second(max)
REFLOW	Temperature(T_L) Total Time above T_L (t_L)	217°C 30-100 seconds
PEAK	Temperature(T_P) Time(t_p)	260°C 2-5 seconds
RAMP-DOWN	Rate	3°C/second(max)
Time from 25°C to Peak Temperature		8 minutes max.
Composition of solder paste		96.5Sn/3Ag/0.5Cu
Solder Paste Model		SHENMAO PF606-P26

The graphic shows temperature profile for component assembly process in reflow ovens

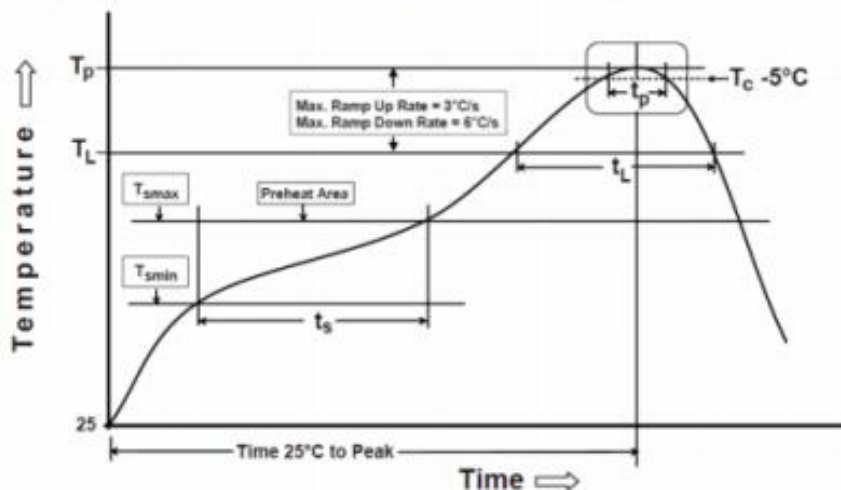

Soldering iron condition: Soldering iron temperature $270^\circ\text{C} \pm 10^\circ\text{C}$.

Apply preheating at 120°C for 2-3 minutes. Finish soldering for each terminal within 3 seconds, if soldering iron temperature over $270^\circ\text{C} \pm 10^\circ\text{C}$ or 3 seconds, it will make cause component surface peeling or damage.

10. Packaging

500 pc SDCP.5900.12.4.A.40 per reel
 Dimensions - Ø330*55mm
 Weight - 2300g

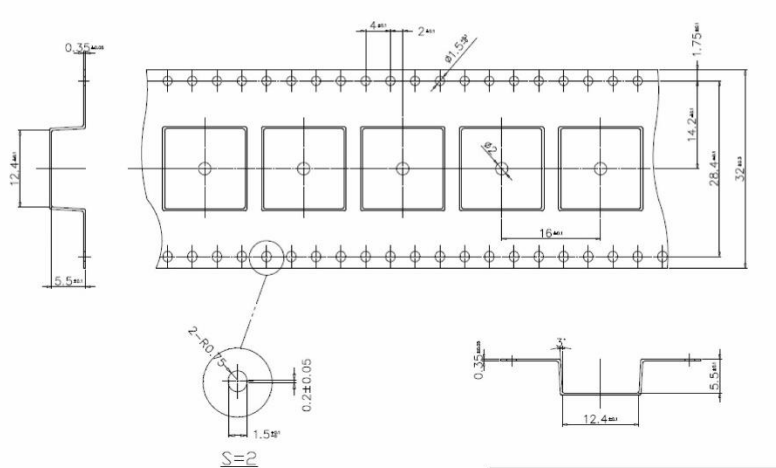
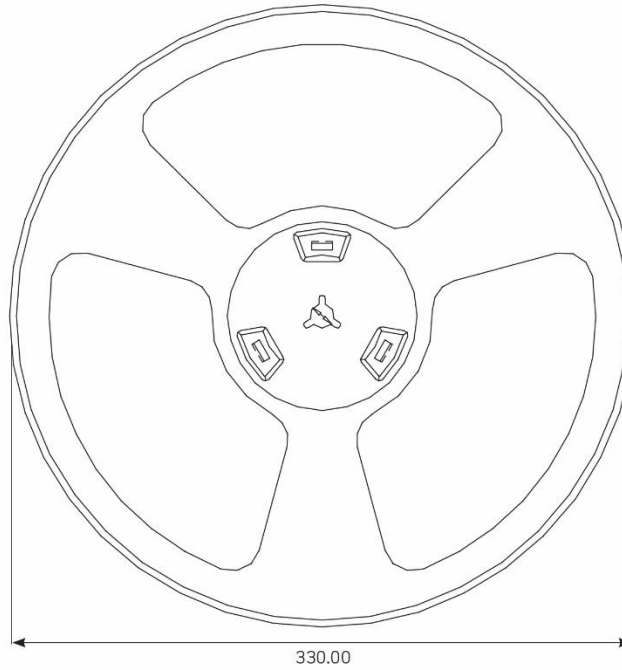

1 pc reel in small in Anti-static Bag
 Dimensions - 340*350*70mm
 Weight - 2400g

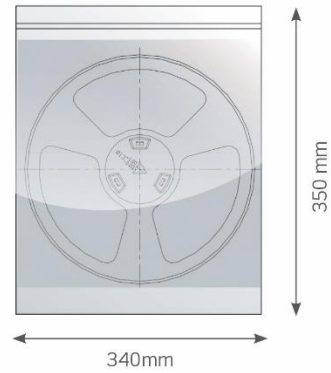

4 Reels in Anti-static Bags
 2000 pcs in one carton
 Carton Dimensions - 370*360*305mm
 Weight - 10.5Kg

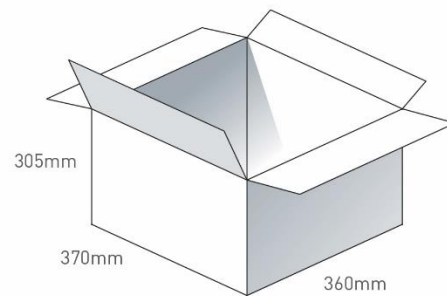

Pallet Dimensions 1200*1000*1420mm
 24 Cartons per Pallet
 6 Cartons per layer
 4 Layers

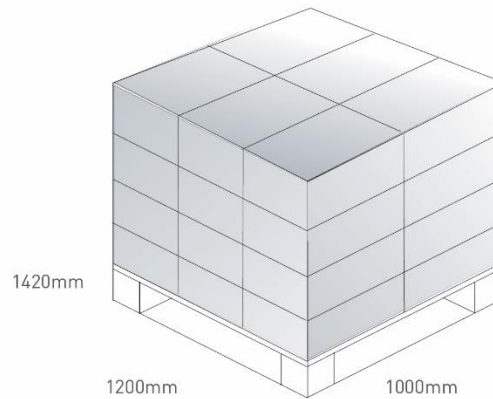

Changelog for the datasheet

SPE-17-8-037– SDCP.5900.12.4.A.40

Revision: E (Current Version)

Date:	2021-10-05
Changes:	Antenna Integration Guide Added
Changes Made by:	Cesar Sousa

Previous Revisions

Revision: D

Date:	2021-10-05
Changes:	Updated VNA measurement graphs.
Changes Made by:	Gary West

Revision: C

Date:	2021-10-05
Changes:	Format Change, MSL
Changes Made by:	Erik Landi

Revision: B

Date:	2021-10-25
Changes:	Updated to C-V2X
Changes Made by:	Jack Conroy

Revision: A (Original First Release)

Date:	2017-7-12
Notes:	Initial Release
Author:	STAFF