

Datasheet SDP1000

Low Range Differential Pressure Sensor for Air and Non-Aggressive Gases



- For HVAC and medical OEM applications
- Unsurpassed performance thanks to CMOSens® technology
- Offset and hysteresis free
- Excellent accuracy and reproducibility even below 10 Pa
- Fully calibrated and temperature compensated
- Linear or square root extracted output characteristics available
- Not sensitive to the mounting orientation
- Direct PCB mounting with simple snap-on system



Datasheet – v5.1

SDP1000 Product Summary

The SDP1000 differential pressure sensors for air cover the following measurement ranges: -5 to 125 Pa (0.5 inch H₂O), and -20 to 500 Pa (2 inch H₂O).

Mounted in a rugged, chemically inert PPS housing the SDP1000 differential pressure sensors feature a unique dynamic range, zero offset and unsurpassed long term stability. This makes it an ideal fit for demanding yet cost sensitive OEM applications in HVAC and medical equipment.

The devices are supplied with 5.0 V and provide a 0.25...4.0 V output. Although the output of the SDP1000 differential pressure sensor is analog, the internal linearization and temperature compensation is performed digitally. This results in a superior accuracy, outstanding resolution, and lowest temperature dependence.

Since fully exchangeable just a few external electronic components around the SDP1000 make a high quality

differential sensor transmitter with e.g. an 0...10 V output or other interfaces.

Its leading performance is based on Sensirion's proprietary CMOSens® sensor technology which combines the sensor element with amplification and A/D conversion on one single silicon chip. The differential pressure is measured by a thermal sensor element. In contrast to other thermal differential pressure sensors only a very small amount of air is required. This leads to a reliable operation even under harsh conditions. In comparison to membrane based sensors the SDP1000 differential pressure sensors show an extended measurement range, better offset stability and improved reproducibility even at lowest pressure ranges. In addition, the SDP1000 is robust against pressure bursts and shows no sensitivity to the mounting orientation.

Applications

- Medical
- HVAC
- Automotive
- Process Automation

Block Diagram

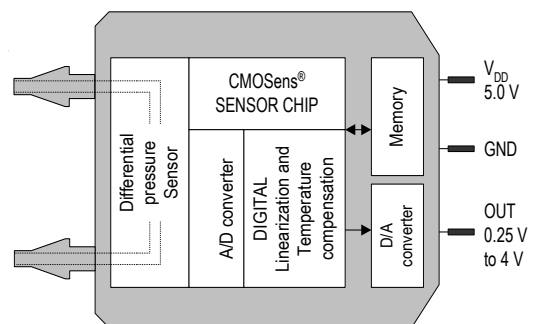

1 Specifications

Table 1: Sensor specifications (at 23°C and $p_{absolute} = 966\text{mbar}$, $VDD = 5.0\text{ V}$ unless otherwise noted).

Parameter	SDP1000-L025			SDP1000-L05			SDP1000-L			Unit
	Min	Typ	Max	Min	Typ	Max	Min	Typ	Max	
Measurement range	-62		62	-5		125	-20		500	Pa
	-0.25		0.25	-0.02		0.5	-0.08		2	Inch water
Power supply (see Tab 4)	4.75	5.00	5.25	4.75	5.00	5.25	4.75	5.00	5.25	V
Full scale output (100 kΩ load)	Typ. 4.00V at +62Pa Typ. 0.20V at -62Pa						4.00			V
Zero Pressure Output	2.10			0.250			0.250			V
Accuracy (also see Figure 1)	0.5			0.2			0.1			% FS ⁽¹⁾⁽²⁾
	1.5			1.5			1			% m.v. ⁽¹⁾
Repeatability	0.3			0.3			0.3			% m.v. ⁽¹⁾
Offset stability	0			0			0			Pa / year
Additional error over temperature (T ≠ 23°C)	0.003			0.003			0			% FS/°C ⁽²⁾
	0.03			0.03			0.03			% m.v./°C
Resolution < 30% FS ⁽¹⁾							0.05			Pa
Resolution 30..70% FS ⁽¹⁾	0.05	0.1	0.2	0.05	0.1	0.2	0.2	0.5	1.5	Pa
Resolution > 70% FS ⁽¹⁾							1.5			Pa

(1) FS = full scale or span, m.v. = measured value, i.e. reading, whichever value is bigger

(2) FS = full scale or span, i.e. for the SDP1000-L it is 500 Pa (2 "H2O), for the SDP1000-L025 it is 62 Pa (0.25 "H2O)

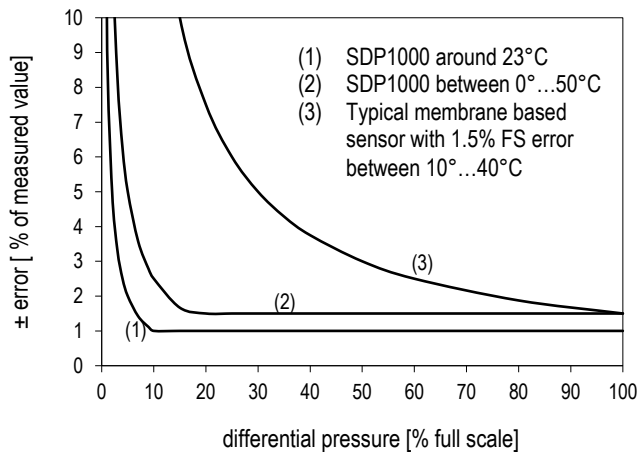

Figure 1: Accuracy (includes errors caused by offset, linearity, hysteresis and repeatability) of the SDP1000-L (1), (2) compared with typical membrane sensors (3).

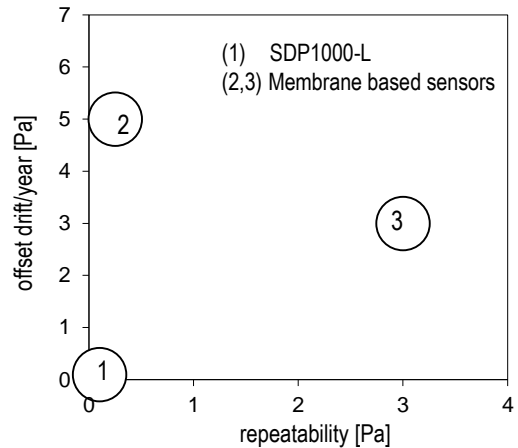

Figure 2: Max. repeatability and offset drift/year of the SDP1000-L (1) compared with two typical membrane based sensors (2,3).

Table 2: Additional sensor specifications.

Media	Air, N ₂ – for other gases contact Sensirion AG.
Operating Conditions: - Temperature - Humidity	-10 °C ... +60 °C / 14°F ... 140 °F non-condensing
Ambient storage conditions ¹	-40 °C ... +80 °C / -40°F ... 176 °F
Orientation sensitivity	below resolution
Response time	40 ms
Admissible overpressure (short term)	1 bar (14.5 PSI)
Burst Pressure Capability	2 bar (29 PSI)
Weight	14 g
Protection Class	IP 20
Wetted materials	Glass (silicon nitride, silicon oxide), Silicon, PPS (Polyphenylene Sulfide), PEEK (Polyetheretherketone), FR4, Silicone as static sealing, Epoxy, Gold
Gas flow through sensor	see Figure 6.
REACH and RoHS	REACH and RoHS compliant

⁽¹⁾ For maximum 2 weeks

1.1 Temperature Compensation

The SDP1000 differential pressure sensors feature a sophisticated built-in temperature compensation circuit. The temperature is measured on the CMOSens chip by means of a PTAT bandgap reference temperature sensor. Its data is fed into a compensation circuit which is also integrated on the CMOSens[®] sensor chip. No external temperature compensation is therefore required.

1.2 Altitude Correction

The SDP1000 differential pressure sensors achieve their unsurpassed performance by using a dynamic measurement principle, i.e. an applied differential pressure forces a small air flow through the sensor. This results in a dependence of the indicated differential pressure on the ambient air density. While the temperature effect is compensated (see Paragraph 1.1) the altitude above sea level has an influence on the SDP1000 output. If desired, this effect can be compensated by a correction factor according to the following equation:

$$Dp_{eff} = Dp_{sensor} + P_{cal} / P_{amb}$$

where Dp_{eff} is the effective differential pressure, Dp_{sensor} the differential pressure indicated by the SDP1000, P_{cal} the absolute pressure during calibration (966 mbar) and P_{amb} the actual ambient absolute pressure.

This leads to the following correction factors:

Table 3: Altitude correction factors.

Altitude [meter]	Ambient Pressure (P_{amb}) [mbar]	Correction Factor P_{cal} / P_{amb}
0	1013	0.95
250	984	0.98
425	966	1.00
500	958	1.01
750	925	1.04
1500	842	1.15
2250	766	1.26
3000	697	1.38

Example:

The SDP1000 is used at 750 m above sea level. The output of the SDP1000 shows 0.5 V, which corresponds to $Dp_{sensor} = 33.3$ Pa. Taking into account the correction factor $P_{cal} / P_{amb} = 1.04$ the effective differential pressure Dp_{eff} is 33.3 Pa * $1.04 = 34.6$ Pa.

Note:

In many HVAC applications such as filter monitoring, fan/ventilator control or air flow measurement the described effect is actually welcome since at the end the mass flow and not volume flow is the effective value to control.

2 Electrical Specifications

2.1 Power Supply

The SDP1000 differential pressure sensors require a stable voltage supply of 5 V. Influence of the supply voltage variation on the offset and the sensitivity are given in Table 5.

2.2 Voltage Output

The SDP1000 features a voltage output from 0.25 V to 4.0 V (Figure 2). An output voltage below 0.25 V indicates a negative differential pressure. This range is not calibrated however. Exempt from this statement is the SDP1000-L025, which features a fully bidirectional calibration with 0.2 to 4.0 V output.

The resistive load at the output pin should be larger than 20 kOhm. The capacitive load at the output pin must not be larger than 200 pF. If the design shows a larger capacity at the output pin an additional resistor is required in series at the output (e.g. 620 Ohm).

Linear output

Formula: $P = \text{Ifactor} * (\text{voltage}^{(1)} - 0.250)/3.750$

Ifactor =	SDP1000-L05	SDP1000-L
Pascal	125	500
Inch water	0.5	2

⁽¹⁾ voltage: measured output voltage in Volt.

For bi-directional SDP1000-L025

Formula: $P = \text{Ifactor} * (\text{voltage} - 2.10)/1.90$

Ifactor = 62 Pa or 0.25 Inch water

Table 4: SDP1000 electrical characteristics.

Parameter	Conditions	Min.	Typ.	Max.	Units
Power Supply Voltage V_{DD}		4.75	5.0	5.25	VDC
Operating Current	5 V, no load, zero flow		4.3	5.2	mA
Output capacitive load C_{load}			20	200	pF
Recommended load R_{load}	To GND	20	100	∞	k Ω

Table 5: Typical power supply dependence of the offset and the sensitivity.

Parameter	Device	4.75 V	5.0 V	5.25 V	Units
Offset	SDP1000-L025	- 3.5		+ 3.5	Pa
	SDP1000-L05	- 0.4		+ 0.4	
	SDP1000-L	- 1.6		+ 1.6	
Sensitivity	SDP1000-L025	29.0	30.6	32.2	mV/Pa
	SDP1000-L05	28	30	32	
	SDP1000-L	7.1	7.5	7.9	

3 Physical Dimensions and Mounting Information

3.1 Housing

The SDP1000 differential pressure sensor is mounted in chemically inert PPS housing. The rugged package has been designed to withstand continuous overpressures of at least 1 bar (14.5 PSI). Burst pressure is > 2 bar (29 PSI)

The physical dimensions and mounting information is given in Figure 4 and 5.

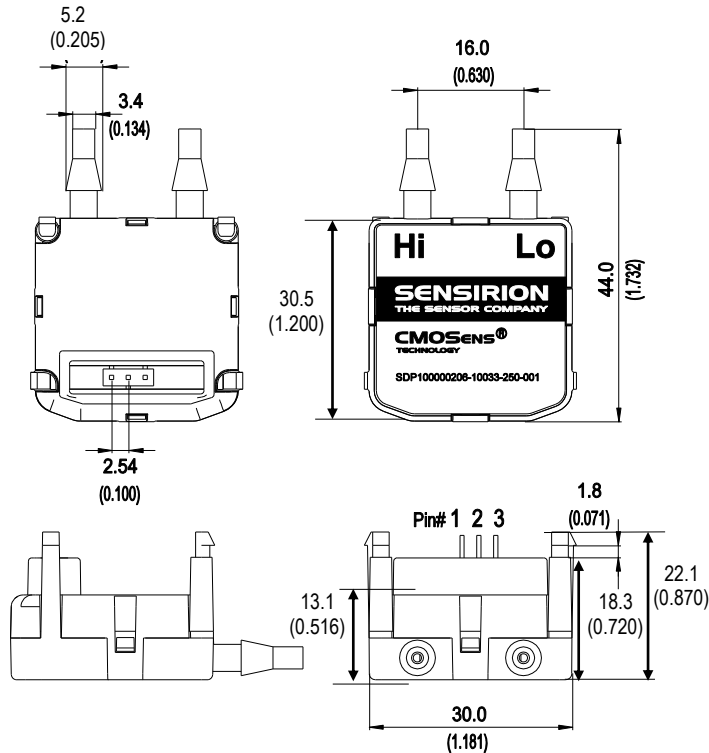

Pin#	Function
1	VDD (5 Vdc)
2	Ground
3	OUT (0.25...4 Vdc)

Figure 4: Pin out and physical dimensions in mm (inch). The drawing is not to scale.

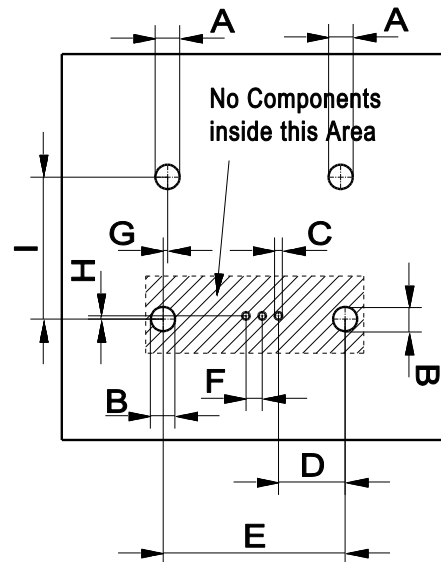

Dim.	[mm]	[inch]	[mil]
A	3.00	0.118	118
B	3.30	0.130	130
C	1.20	0.047	47
D	10.20	0.402	402
E	28.20	1.110	1110
F	2.54	0.100	100
G	0.60	0.024	24
H	0.50	0.020	20
I	22.70	0.894	894

Figure 5: SDP1000 PCB footprint. The drawing is not to scale.

3.2 Soldering Instructions

The SDP1000 differential pressure sensor can be wave soldered. Direct reflow soldering is not recommended since it may affect the accuracy. If reflow soldering is required Sensirion recommends to use an SMD connector (e.g. type Samtec SSM-103-L-SV) and to mount the SDP1000 after soldering.

3.3 Connecting Hose

Sensirion recommends a hose with an inner diameter of 1/8 to 3/20 inch (3.18 to 3.8mm). Due to the dynamic measurement principle, a small air flow is

required (Figure 6) which leads to a dependence on the length of the hose (Figure 7). Tubes up to 1 m show less than 1 % error of the measured value (Figure 7).

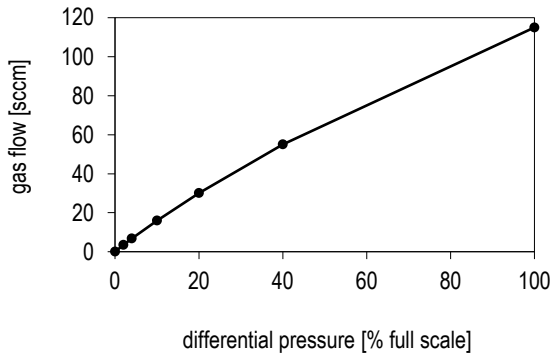

Figure 6: Typical air flow through the SDP1000. Please note: 1 sccm = 1 cm³/min at 0°C and 1013 mbar pressure (1 sccm = 0.001 norm liter).

Length of the connecting hose	Deviation of Measured Value
0.5 m (20 inch)	- 0.4 %
1.0 m (40 inch)	- 0.8 %
2.0 m (80 inch)	- 1.6 %
4.0 m (160 inch)	- 3.2 %

Figure 7: Influence of the length of the connecting hose on the accuracy (using 3/16 inch inner diameter). Example: a 50 Pa difference pressure is shown as 49.8 Pa when using 0.5 m tube with 3/16 inch diameter.

4 Ordering Information

When ordering SDP1000 differential pressure sensors please refer to the following part names and article numbers. For the latest product information and local distributor check out Sensirion's website on <http://www.sensirion.com>

Table 6: Overview ordering information

Part Name	Output	Range (Full Scale)				Article Number
SDP1000-L025	Voltage 0.2 – 4.0 V, linear	± 62 Pa	± 0.62 mbar	± 0.25 "H ₂ O	± 0.009 PSI	1-100313-03
SDP1000-L05	Voltage 0.25 - 4.0 V, linear	125 Pa	1.25 mbar	0.5 "H ₂ O	0.018 PSI	1-100235-03
SDP1000-L	Voltage 0.25 - 4.0 V, linear	500 Pa	5 mbar	2 "H ₂ O	0.07 PSI	1-100110-03

5 Revision history

Table 7: Revision history

Date	Version	Page(s)	Changes
November 2002	Preliminary v0.9	all	First preliminary release
January 2003	First release	all	Specifications, typos, various small modifications
December 2004	V2.6	all	Introduction type L05
Juni 2005	V2.7	all	Change of address, adjusted specifications for type L05
March 2006	V2.8	all	Introduction of Sensirion USA address, updated disclaimer
March 2006	V2.9	2,6	New Calibration temperature: 23°C. Change of barbs/ports diameter specification
October 2006	V3.0	1,8,9	RoHS statement, Introduction of revision history in this document
May 2008	V3.1	All	RoHS statement on page 3, New disclaimer on page 10, Contact addresses updated, Various small modifications, Inconsistency in Zero Pressure / Full Scale Output corrected
September 2008	V4.0	2-5,8	SDP2000-R discontinued, new SDP1000-L025 implemented, power consumption, power supply dependence and temperature dependence changed due to new SF04 sensor chip version, article number index counted up due to new sensor chip version. Small linguistic adaptations.
October 2011	V4.1	1	Block diagram changed
February 2013	V5	all	Updated product number. Minor updates.
April 2017	V5.1	all	Removed SDP1000-R and moved SDP2000-L to separate datasheet No changes to SDP1000 specifications