

Datasheet SDP1108-R

Low Differential Pressure Sensor with fast response time

- For medical ventilators (ICU and home care)
- High sensitivity below 10 Pa to measure small volume flow (neonatal)
- Fast response time for efficient trigger function
- Unsurpassed performance thanks to CMOSens® technology
- Offset and hysteresis free
- Fully calibrated and temperature compensated
- Not sensitive to the mounting orientation and vibrations



SDP1108-R Product Summary

The SDP1108-R sensor is a differential pressure sensor for air based on the successful SDP1000 sensor from Sensirion. The response time of the SDP1108-R has been optimized for medical ventilation applications.

Mounted in a rugged, chemically inert PPS housing the SDP1108-R differential pressure sensors feature a unique dynamic range, zero offset and unsurpassed **long term stability**. This makes it an ideal fit for demanding yet cost sensitive OEM applications in medical and HVAC equipment.

The SDP1108-R is supplied with **5.0 V** and provides a **0.25...4.0 V output**. Although the output of the sensor is analog, the internal linearization and **temperature compensation** is performed digitally. This results in a

superior accuracy, outstanding resolution (up to 0.05 Pa), and lowest temperature dependence.

Its leading performance is based on Sensirion's proprietary CMOSens® sensor technology which combines the sensor element with amplification and A/D conversion on one single silicon chip. The differential pressure is measured by a thermal sensing element. In contrast to other thermal differential pressure sensors only a very small amount of air is required. This leads to a reliable operation even under harsh conditions. In comparison to membrane and piezo-resistive based sensors the SDP1108-R differential pressure sensors show an extended measurement range, better **offset stability** and improved reproducibility even at lowest pressure ranges. In addition the SDP1108-R is robust against pressure bursts and shows no sensitivity to the mounting orientation.

Applications

Medical applications:

- Homecare ventilation
- Intensive care ventilation (ICU)

Block Diagram

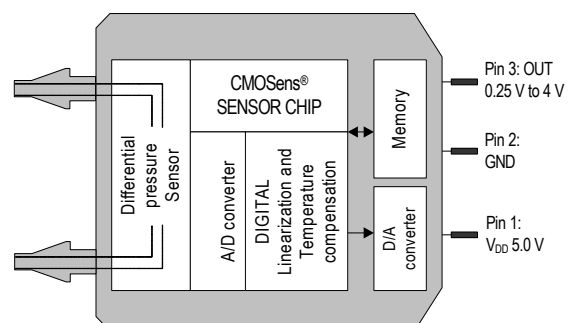

1 Sensor Output Characteristics¹

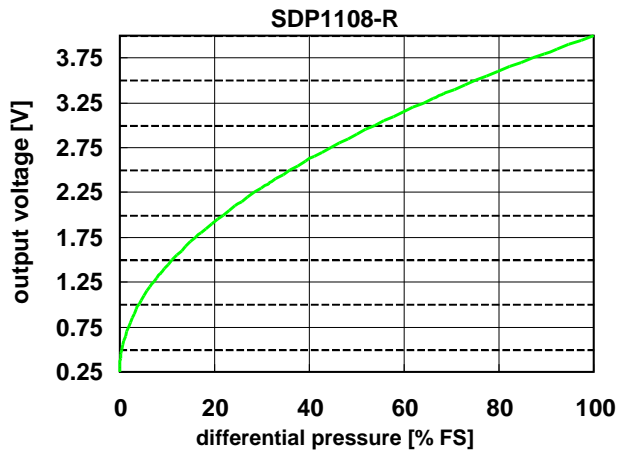

The SDP1108-R provides a fully calibrated voltage output. To enhance the sensitivity at very low differential pressures, the SDP1108-R comes with a root-square output characteristic.

$$\text{Diff. Press [Pa]} = \left(\frac{\text{Output Voltage} - 0.25\text{V}}{3.75\text{V}} \right)^2 \cdot 500$$

Use this formula to convert the sensor output into physical value.

¹Calibration conditions apply unless otherwise noted: 23°C and $p_{\text{absolute}} = 966 \text{ mbar}$, dry air, $V_{\text{DD}} = 5.000 \text{ V}$.

2 Specifications

Table 1: SDP1108-R Sensor specifications¹

Parameter		SDP1108-R			Unit
		Min	Typ	Max	
Measurement range		0.25	-	4	Volts
		0	-	500	Pa
		0	-	2	Inch water
Accuracy ³	20% FS to 100% FS	-	1.0	2.0	% Measured Value ⁴
	0 to 20% FS	-	0.2	0.4	% Full Span ⁵
	zero ²	-	15 0.01	40 0.06	mV Pa
Repeatability	100 to 500 Pa	-	0.3	1.0	% Measured Value
	0 to 100 Pa	-	0.05	0.2	% Full Span ⁵
Null drift per year ⁶		-	0	0.1	Pa / year
Additional error over temperature ⁷ (T ≠ 23°C)	0 to 100 % FS	-	0.03	0.05	% Measured Value ⁴ / °C
	zero	-	1	2	mV/°C
Response time ⁽⁸⁾		6.6	8.0	10.1	ms
Cut off frequency of internal filter		17	20	24	Hz

¹ Calibration conditions apply unless otherwise noted: 23°C and $p_{\text{absolute}} = 966 \text{ mbar}$, dry air, $V_{\text{DD}} = 5.000 \text{ V}$

² Variance between the zero point (offset) of different sensors measured under the same conditions (e.g. same supply voltage, temperature, ...)

³ Include deviations due to linearity, hysteresis, and repeatability

⁴ % Measured value = (SDP1108-R output [Pa] - output of reference instrument [Pa]) / output of reference instrument [Pa].

⁵ Full span is defined as 3750 mV / 500 Pa for SDP1108-R

⁶ Drift over time due to aging, pressure cycles... Test results can be provided.

⁷ The additional error due to temperature variation is temporary. Once the sensor is back to the calibration temperature, the shift disappears (no hysteresis).

⁸ Tau= 0 to 63%, filter response time = 8ms.

Table 2: Additional sensor specifications.

Parameter			
Media Calibration ¹	Air, N ₂ – for other gases contact Sensirion AG.		
Media Compatibility	Air, N ₂ , O ₂		
Operating Conditions ² : - Temperature - Humidity	-10 °C ... +60 °C / 14°F ... 140 °F non-condensing		
Ambient storage conditions ³	-40 °C ... +80 °C / -40°F ... 176 °F		
Orientation sensitivity	below zero point accuracy		
Admissible overpressure (short term)	1 bar (14.5 PSI)		
Burst Pressure Capability	2 bar (29 PSI)		
Weight	14 g		
Protection Class	IP 20		
Wetted materials	Glass (silicon nitride, silicon oxide), Silicon, PPS (Polyphenylene Sulfide), PEEK (Polyetheretherketone), FR4, Silicone as static sealing, Epoxy, Gold		
Electromagnetic compatibility	EN 61000-4-2	Air discharge (ESD)	± 2 kV
Lead free	Reach and RoHS compliant.		

¹ Sensors are calibrated for a specific gas, please contact Sensirion when you employ different gases than the specified.

²Condensation of liquids or dust on the sensor membrane might lead to sensor offset.

³For maximum 2 weeks

2.1 Temperature Compensation

The SDP1108-R differential pressure sensor features a sophisticated built-in temperature compensation circuit. The temperature is measured on the CMOSens[®] chip by means of a PTAT bandgap reference temperature sensor. Its data is fed into a compensation circuit which is also integrated on the CMOSens[®] sensor chip. No external temperature compensation is therefore required.

2.2 Altitude Correction

The SDP1108-R differential pressure sensor achieves its unsurpassed performance by using a dynamic measurement principle: An applied differential pressure forces a small air flow through the SDP1108-R, which measures this air flow.

The sensor signal is dependent on the ambient air density. The temperature effect on density is compensated by internal intelligence (see Paragraph 2.1). Effects on density due to a change of ambient pressure, typically a change of altitude above sea level, can be compensated using a correction factor according to the following equation:

$$Dp_{eff} = Dp_{sensor} * P_{cal} / P_{amb}$$

Where Dp_{eff} is the effective differential pressure, Dp_{sensor} the differential pressure indicated by the SDP1108-R, P_{cal} the absolute pressure during calibration (966 mbar) and P_{amb} the actual ambient absolute pressure.

This leads to the following correction factors:

Table 3: Altitude correction factors.

Altitude [meter]	Ambient Pressure (P_{amb}) [mbar]	Correction Factor P_{cal} / P_{amb}
0	1013	0.95
250	984	0.98
425	966	1.00
500	958	1.01
750	925	1.04
1500	842	1.15
2250	766	1.26
3000	697	1.38

Example:

The SDP1108-R is used at 750 m above sea level. The output of the SDP1108-R shows 0.5 V, which corresponds to $Dp_{sensor} = 33.3$ Pa. Taking into account the correction factor $P_{cal} / P_{amb} = 1.04$ the effective differential pressure Dp_{eff} is 33.3 Pa * $1.04 = 34.6$ Pa.

Note:

In many medical and HVAC applications such as filter monitoring, fan/ventilator control or air flow measurement the described effect is actually welcome since at the end the mass flow and not volume flow is the effective value to control.

3 Physical Dimensions and Mounting Information

3.1 Housing

The SDP1108-R differential pressure sensor is mounted in chemically inert PPS housing. The rugged package has been designed to withstand continuous overpressures of at least 1 bar (14.5 PSI). Burst pressure is > 2 bar (29 PSI)

The physical dimensions and mounting information is given in Figure 1 and 2.

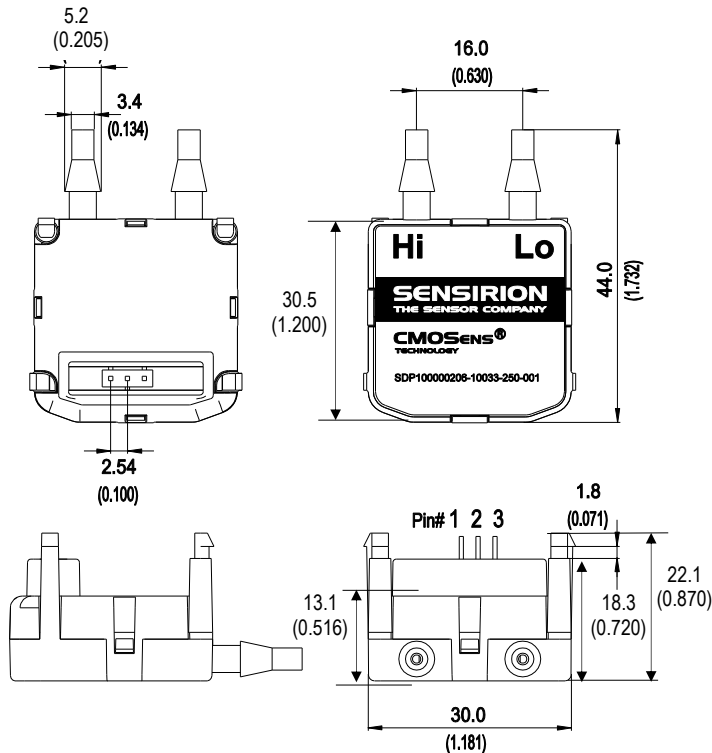

Pin#	Function
1	VDD (5 Vdc)
2	Ground
3	OUT (0.25...4 Vdc)

Figure 1: Pin out and physical dimensions in mm (inch). The drawing is not to scale.

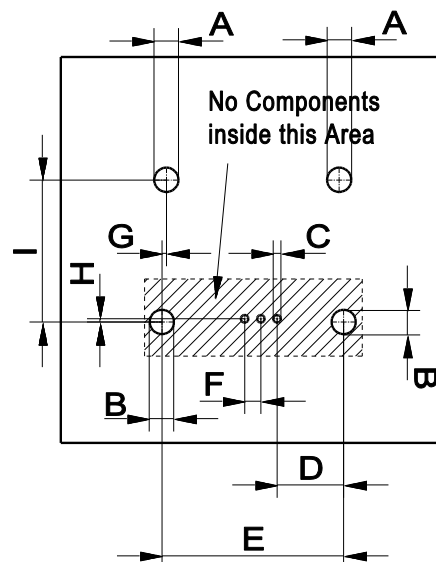

Dim.	[mm]	[inch]	[mil]
A	3.00	0.118	118
B	3.30	0.130	130
C	1.20	0.047	47
D	10.20	0.402	402
E	28.20	1.110	1110
F	2.54	0.100	100
G	0.60	0.024	24
H	0.50	0.020	20
I	22.70	0.894	894

Figure 2: SDP1108-R PCB footprint. The drawing is not to scale.

3.2 Soldering Instructions

The SDP1108-R differential pressure sensor can be wave soldered. Direct reflow soldering is not recommended since it may affect the accuracy.

If reflow soldering is required Sensirion recommends to use an SMD connector (e.g. type Samtec SSM-103-L-SV) and to mount the SDP1108-R after soldering.

3.3 Connecting Hose

Sensirion recommends a hose with an inner diameter of 3.18 to 3.8mm (1/8 to 3/20 inch). Due to the dynamic measurement principle, a small air flow is required (Figure 3) which leads to a dependence on the length

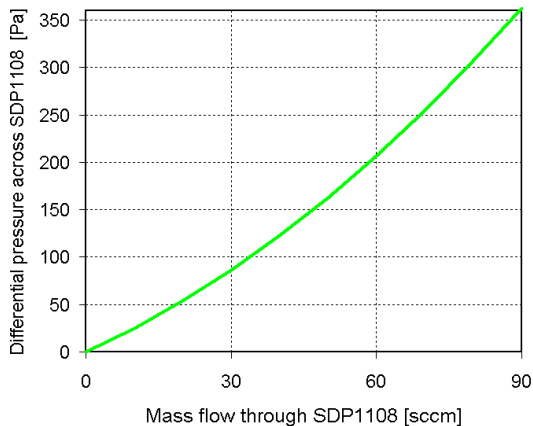

Figure 3: Typical air flow through the SDP1108-R. Please note: 1 scc/min = 1 cm³/min at 0°C and 1013 mbar pressure (1 sccm = 0.001 norm liter).

of the hose (Table 4). Tubes up to 1 m show less than 2 % error of the measured value (Table 4).

Table 4: Influence of the length of the connecting hose on the accuracy (using 4 mm inner diameter). Deviation is given in % of the measured value. Example SDP1108-R: a 500 Pa difference pressure is shown as 492.5 Pa when using 1 m tube with 4 mm inner diameter.

Hose length	SDP1108-R	
	@FS	@0.5 FS
0.5 m (20 inch)	-0.75%	-0.95%
1.0 m (40 inch)	-1.5%	-1.9%
2.0 m (80 inch)	-3.0%	-3.8%

Table 5: Maximum flow through the sensor element.

	SDP1108-R
Mass flow through sensor element:	123 sccm (@ 500 Pa)

4 Electrical Specifications

4.1 Power Supply

The SDP1108-R differential pressure sensor requires a stable voltage supply of 5.0 V. The requirements for the electrical supply are specified in Table 6.

The resistive load at the output pin should be larger than 20 kOhm. The capacitive load at the output pin must not be larger than 200 pF. If the design shows a larger capacity at the output pin an additional resistor is required in series at the output (e.g. 620 Ohm).

4.2 Voltage Output

The SDP1108-R features a voltage output from 0.25 V to 4.0 V. An output voltage below 0.25 V indicates a negative differential pressure (not calibrated).

Table 6: SDP1108-R electrical characteristics.

Parameter	Conditions	Min.	Typ.	Max.	Units
Power Supply Voltage V_{DD}		4.75	5.0	5.25	VDC
Operating Current	5 V, no load, zero flow		5.1	6	mA
Output capacitive load C_{load}			20	200	pF
Recommended load R_{load}		20	100	∞	k Ω

5 Ordering Information

When ordering please refer to the following part names and article numbers. For the latest product information and local distributor check out Sensirion's website on <http://www.sensirion.com>

Part Name	Article Number
SDP1108-R	1-100339-03

Revision history

Date	Revision	Author	Changes
October 2008	V1.0	PHA	Initial release
June 2010	V1.1	DAT	SDP2108 launched, New Item Number (see product change notification PCN 081015), block diagram (page 1), minor changes
February 2013	V2	ANB	Updated product number. Minor layout updates.
November 2016	V2.1	ANB	SDP2108-R discontinued and removed from datasheet.