

# Safety Laser Scanner SE2L

---





## Area Protection

Ensures the safety of humans in a hazardous area, or those approaching the machine.

### Distance 5m, sensing angle 270°

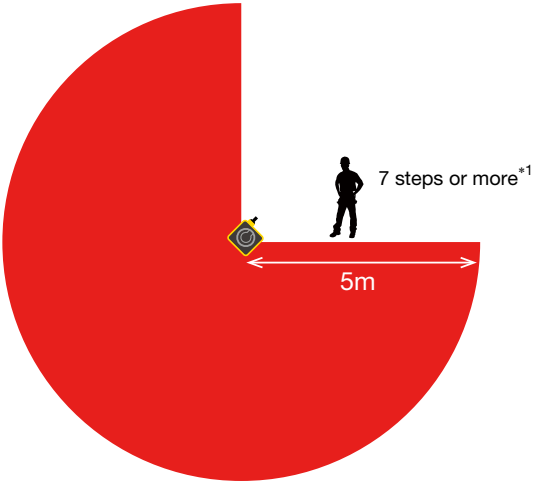

One SE2L protects a wide area (270° and 5m) and can be used in a variety of applications such as large sized systems or long conveyor lines.

\*1: average stride length (70 cm) of a 170 cm person

### Ensures productivity and safety

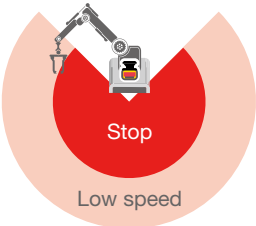

The SE2L is a safety sensor that can detect approach. Stop area can be made smaller by detecting approach at the additional protection zone to start slowdown. (Conventional configuration of one protection zone + two warning zones is possible)

### Master slave function, first in its industry



A maximum of four SE2Ls can be interconnected using RS-485 for master/slave operation.

## IDEC's safety products for safe and productive production lines



**RF2 force-guided relay (2-pole)**

Can be used as interface relays to send input signals to a controller, or to amplify current for driving a contactor.



**RF1V force-guided relay (4-pole/6-pole)**

Can interrupt a small load directly.





## Access Protection

Allows only objects to pass through. Detects the access of humans.



## Dual protection function

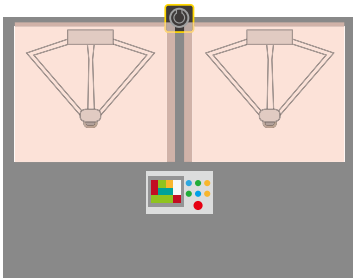

An SE2L can monitor two separate hazardous areas to stop machines when detecting the access of humans. No reflective sensor is necessary, thus eliminating the need of optical axis alignment. Can replace two light curtains.

## Ensures safety at positional change

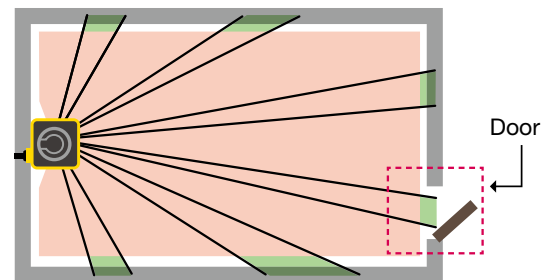

Reference monitoring function ensures safety by detecting the positional change of SE2L or reference boundary, such as a door's opening/closing status.

## Ensures safety at entrance of works. Override function enables restart from unintended stop.

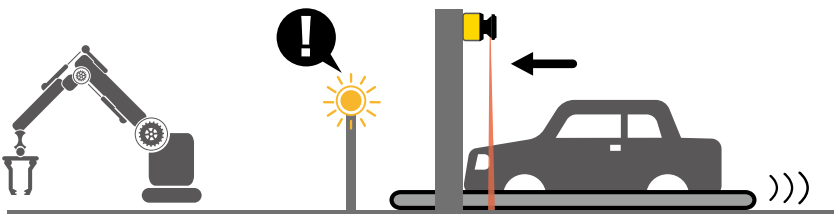

By disabling some areas of protection zone, muting function allows objects to enter the hazardous area without stopping the machine.

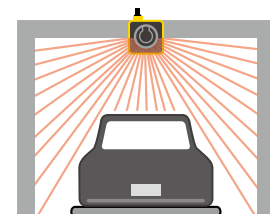

With override function, when stopped by errors at muting status, the work can be moved easily.



### FS1A Safety Controller

A variety of safety products can be connected to the controller equipped with various control logics.



### LD6A LED SignalLight Towers

Used to indicate the status of processes. Visible even at a distance.

## Collision Avoidance

Protects humans from colliding.  
Also prevents loads on from falling.



### A maximum of 32 area patterns

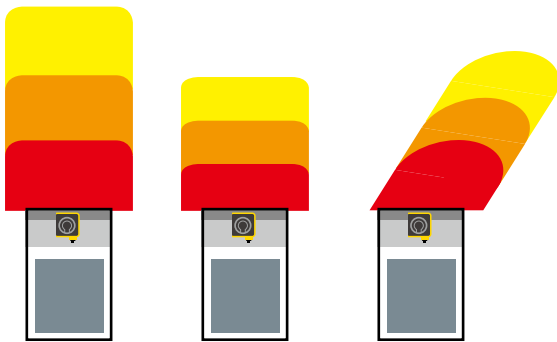

A maximum of 32 area patterns can be configured/switched according to the mobile application such as AGV, ensuring the optimum protection in various applications.

### Utilize distance measurement data

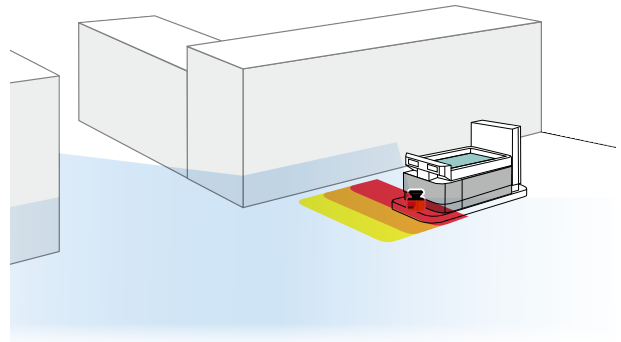

During safety protection, the SE2L can send out distance measurement data through the Ethernet port, in order to obtain the data of the obstacles.

### Monitors external output equipment

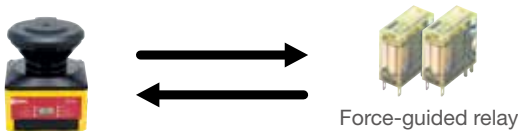

EDM function monitors the status of external devices, enabling monitoring of welded contacts and such.

### Encoder inputs

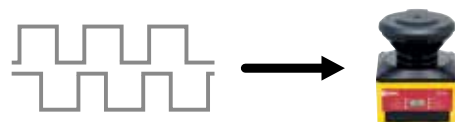

Pulse signals from an incremental encoder can be sent to the SE2L directly without a controller, enabling to switch areas easily depending on the speed.

IDEC's safety products  
for safe and productive  
production lines



Emergency Stop Switches  
XW/XN/X6

A variety of models to choose from.

## Excellent Usability

Easy-to-use configuration and useful functions for simple and comfortable maintenance.

### Supports area configuration

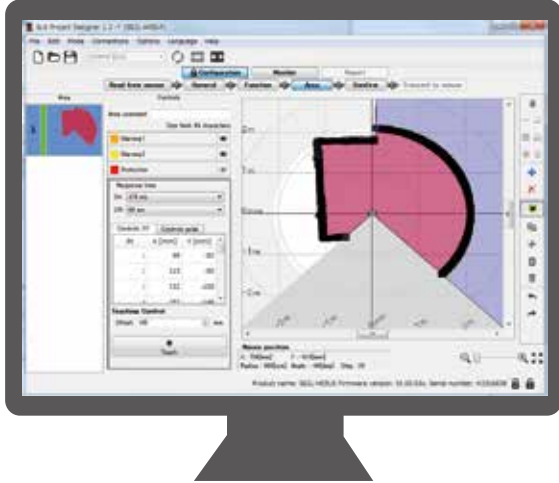

Teaching function enables automatic area configuration by referring to obstacles such as walls and columns. Area can be configured easily even with complicated background.

### Check detection status with video

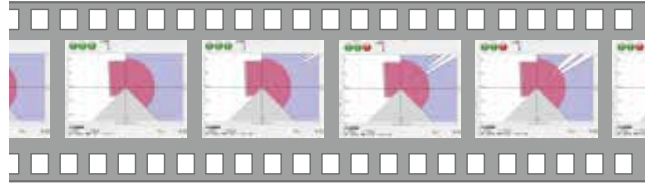

No human in the protection zone    Human approaching the protection zone    Human inside the protection zone

Area data and distance measurement data can be recorded while monitoring on PC. Video of detection status can be replayed with the file.

### Reduce maintenance and start-up time



Area data and function settings created on PC can be transferred to the SE2L using not only by USB cable but also micro SD card.

### Detection log report reduces maintenance

Log	ID	Min distance	Stop
Log1	Area: 1 Protection1: OFF	Protection1: 108 [mm]	Protection1: 534    2016/04/21 11:30:57
Log2	Area: 1 Protection1: OFF	Protection1: 115 [mm]	Protection1: 578    2016/04/21 11:30:59
Log3	Area: 1 Protection1: OFF	Protection1: 111 [mm]	Protection1: 566    2016/04/21 11:31:00



Operational status is displayed on the SE2L. It can also be displayed on PC to monitor errors and data log for easy trouble shooting.

### Stable operation even in dusty environment



Checks dust in air with signals and reduces unintended detection. Safety function is not impaired.

### Optical window can be replaced on-site



Cover Bracket

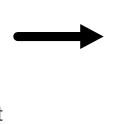

Optical Window

Optical window can be replaced by the user, reducing downtime and cost. A cover bracket to protect the SE2L for damage by collision is also available.

## IDEC Safety Solution

- Safety system
- Safety consulting
- Risk assessment
- Safety seminars

IDEC—Committed to creating the optimum safety environment—both for humans and systems.







# SE2L Safety Laser Scanner

## SE2L Safety Laser Scanner

### Model











Package Quantity: 1

Name & Shape	Cable Length	Part No.	Remarks
Cable Model 	3m	SE2L-H05LP	<ul style="list-style-type: none"> <li>Attachment: SLS Project Designer CD (includes: User's Manual, SLS_Optical Window Adjuster)</li> <li>Applicable OS: Windows XP, 32 bit (SP3 or higher) Windows 7, 32/64 bit (SP1 or higher) Windows 8, 32/64 bit Windows 8.1, 32/64 bit Windows 10 32/64 bit</li> </ul>
Connector Model  <b>NEW</b>	0.3m	SE2L-H05LPC	

### Accessories (optional)

Package Quantity: 1

Part No.	Cable Length	Part No.	Remarks
Connector Cable 	2m	SE9Z-HS2-C002	<ul style="list-style-type: none"> <li>Degree of protection: IP65</li> <li>Used with connector model SE2L-H05LPC only.</li> </ul>
	5m	SE9Z-HS2-C005	
	10m	SE9Z-HS2-C010	
	20m	SE9Z-HS2-C020	
Micro USB Cable 	1m	SE9Z-HS2-XCM11	<ul style="list-style-type: none"> <li>Used to connect the SE2L and PC.</li> </ul>
Ethernet Cable 	3m	SE9Z-HS2-XCD13	<ul style="list-style-type: none"> <li>Degree of protection: IP65</li> <li>Waterproof LAN cable</li> </ul>
Extension Cable	10m	SE9Z-HS2-XCE010	<ul style="list-style-type: none"> <li>Used to extend the cable length of the SE2L.</li> </ul>
	20m	SE9Z-HS2-XCE020	
Base Mounting Bracket 		SE9Z-HS2-BK01	<ul style="list-style-type: none"> <li>Used to change the vertical angle alignment of the SE2L.</li> <li>Adjustable by 15 degrees total (7.5 degrees each direction)</li> <li>Material: iron</li> <li>Attachment: Four bolts (M5×12)</li> </ul>
Rear Mounting Bracket 		SE9Z-HS2-BK02	<ul style="list-style-type: none"> <li>Used to change the vertical/horizontal angle adjustment of the SE2L.</li> <li>Adjustable by 15 degrees total (7.5 degrees each direction)</li> <li>Material: iron</li> <li>Attachment: Four bolts (M5×12)</li> </ul>
Simple Base Mounting Bracket  <b>NEW</b>		SE9Z-HS2-BK03	<ul style="list-style-type: none"> <li>Attachment: Four bolts (M5×10)</li> </ul>
Rear Mounting Bracket  <b>NEW</b>		SE9Z-HS2-BK04L	<ul style="list-style-type: none"> <li>Attachment: Four bolts (M5×10)</li> </ul>
Cover Bracket 		SE9Z-HS2-CM01	<ul style="list-style-type: none"> <li>Used to protect the optical window in combination with base mounting bracket or rear mounting bracket.</li> <li>Material: iron</li> <li>Attachment: Four bolts (M5×12)</li> </ul>
Optical Window 		SE9Z-HS2-WD01	<ul style="list-style-type: none"> <li>Material: polycarbonate</li> <li>Attachment: Four bolts (M3×8)</li> </ul>

## Safety Products



### Safety Controller

Name & Shape	Part No.	Remarks
	FS1A-C11S	• 24 logics
	FS1A-C21S	• 11 logics



### LED SignalLight Tower

Name & Shape	Part No.	Remarks
	LD6A-*	<ul style="list-style-type: none"> <li>Degree of protection: IP65</li> </ul>

### Force-guided Relay

Name & Shape	Part No.	Remarks
2-pole 	RF2S-*	<ul style="list-style-type: none"> <li>Force guided contact mechanism (EN50205 Type A TÜV approved).</li> </ul>
	RF2V-*	
4-pole 	RF1V-*	
6-pole 	RF1V-*	

### Emergency Stop Switches

Name & Shape	Part No.	Remarks
ø30mm 	XN1E-*	<ul style="list-style-type: none"> <li>Degree of protection: IP65</li> </ul>
ø22mm 		
ø16mm 	AB6E-*	

\* See product catalogs or IDEC's website for detailed part no.

# SE2L Safety Laser Scanner

## Performance Specifications

Part No.		SE2L-H05LP/SE2L-H05LPC
Sensing Characteristics	Protection Zone	5.0m maximum
	Warning Zone (Note 1)	20m maximum (non-safety)
	Additional Safety Distance (Note 2)	+100 mm
	Sensing Characteristics	Black reflector sheet (1.8%) to retro-reflector sheet
	Sensing Angle	270°
	Minimum Sensing Width	ø30 mm (maximum distance: 1.8m) ø50 mm (maximum distance: 3.0m) ø70 mm/ø150 mm (maximum distance: 5.0m)
	Scan Cycle	30 ms (rotating speed 2,000 rpm)
	Scan Area	32 patterns maximum
	Response Time	ON→OFF: 60 to 510 ms OFF→ON: 270 to 510 ms
Light Source	Element	Pulse laser diode
	Wavelength	905nm
	Laser Class	Laser class 1 (IEC 60825-1)
Type	Type 3 (IEC 61946-1, IEC 61496-3)	
Functional Safety	SIL 2 (Type B, HFT=1) (IEC 61508)	
PFHd	7.8×10 <sup>-8</sup> (T1=20 years): when master slave function is disabled 1.6×10 <sup>-7</sup> (T1=20 years): when master slave function is enabled	
Master Slave Connection	4 maximum	
Enclosure	Dimensions	80W × 80D × 95H (mm) (cable not included)
	Weight (approx.)	Cable model: 0.8 kg (incl. cable)/Connector model 0.5 kg
	Degree of Protection	IP65 (IEC 60529)
	Material	Body: aluminum diecast / Optical window: polycarbonate
	Cable	Cable model: 3 m/Connector model 0.3 m
Power Voltage	24V DC ±10%: power from converter 24V DC -30%/+20%: power from battery	
Power Consumption	Without Output Load	6W
	Maximum (without output load)	50W
Output	OSSD1/2 (safety)	Output type (high side SW)
		Output current (maximum: 500 mA) (Note 3)
		Leakage current (maximum: 1 mA)
		Cable (AWG 26)
		Allowable load (L/R=25 ms, C=1μF)
	OSSD3 (safety) OSSD4 (safety) WARNING1 (non-safety) WARNING2 (non-safety)	Output type (high side SW)
		Output current (maximum: 250 mA) (Note 3)
		Leakage current (maximum: 1 mA)
	RES_REQ1, RES_REQ2, MUT_OUT1, MUT_OUT2	Cable (AWG 28)
Allowable load (L/R=25 ms, C=1μF)		
Output type (PNP transistor output)		
Input	Area Switching (5 inputs × 2 channels) EDM1/EDM2/MUTING1/MUTING2/ MUTING3/MUTING4/OVERRIDE1/ OVERRIDE2/RESET1/RESET2/ ENC1_A/ENC1_B/ENC2_A/ENC2_B	Input Resistance: 4.7kΩ Cable: AWG 28
	PC	USB2.0 (USB micro type-B connector)
	Master Slave	RS-485 (cable)
Interface	Distance Measurement Data Output	Ethernet 100BASE-TX (water proof connector)
Environmental Resistance	Operating Temperature	-10 to +50°C (no freezing)
	Storage Temperature	-25 to +70°C (no freezing)
	Operating Humidity	95% RH (no condensation)
	Storage Humidity	95% RH (no condensation)
	Surrounding Light Intensity (Note 4)	1500 lx maximum
	Vibration Resistance	Frequency: 10 to 55 Hz Sweep: 1 octave/minute Amplitude: 0.35 mm ±0.05 mm
	Shock Resistance	Acceleration: 98 m/s <sup>2</sup> (10G) Pulse duration: 16 ms
	Outdoor Operation	Not permitted
	Altitude	Below 2,000m

Note 1: When the reflectance of object is 90% or above.

Note 2: Additional distance of 200 mm is needed when the SE2L operates under high reflective background.

Note 3: Total current supply of OSSD output and warning output should be below 1.0A.

Note 4: The angle between the sensing plane and the light source should be more than 5 degrees.

# SE2L Safety Laser Scanner

## Dimensions

### Safety Laser Scanner SE2L-H05LP□

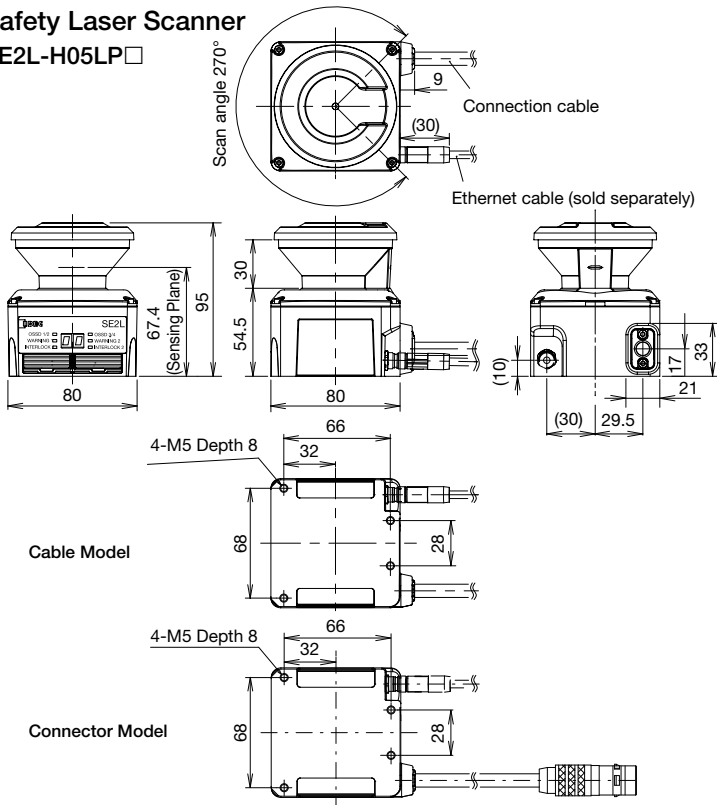

### Cover Bracket SE9Z-HS2-CM01

All dimensions in mm.

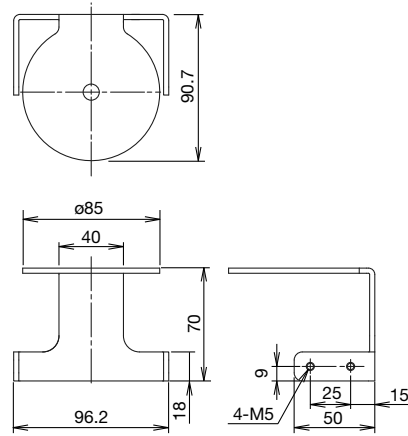

- Used to protect the optical window in combination with base mounting bracket or rear mounting bracket. Cannot be used with simple base mounting bracket or rear mounting bracket.

### Base Mounting Bracket SE9Z-HS2-BK01

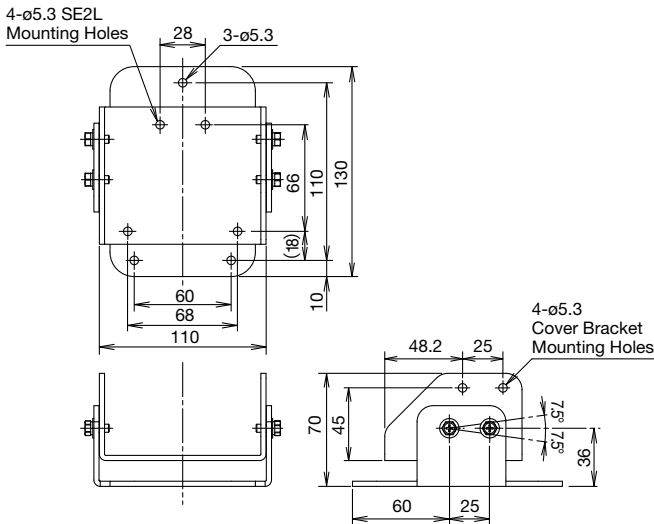

### Rear Mounting Bracket SE9Z-HS2-BK02

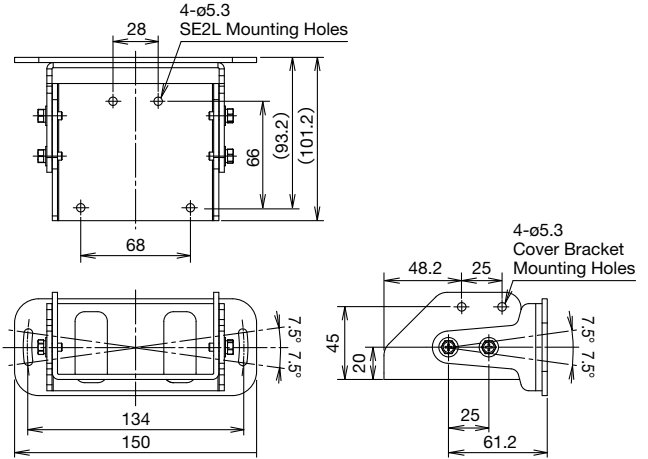

### Simple Base Mounting Bracket SE9Z-HS2-BK03 (Note 1)

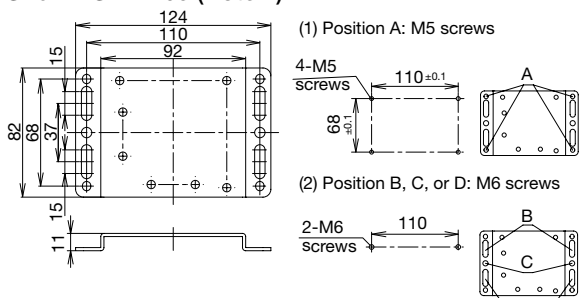

### Rear Mounting Bracket SE9Z-HS2-BK04L (Note 1)

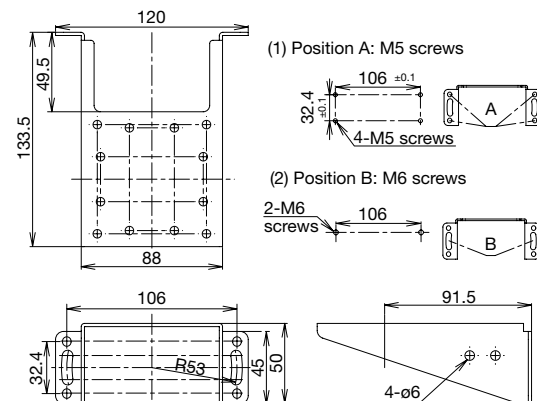

- Note 1:
- Use washers when fastening screws.
  - Use two M6 screws when installing on an aluminum frame.



# SE2L Safety Laser Scanner

## Wiring Examples

a) When using 32 scanning areas (e.g. AGV)

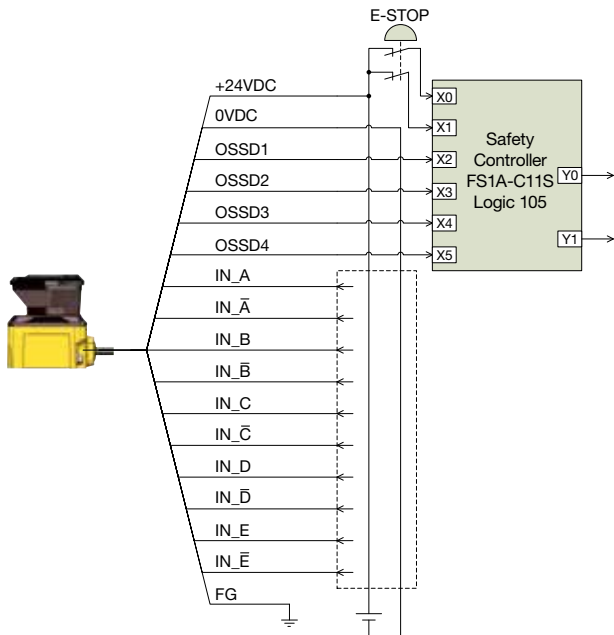

**IDEC safety products**  
 Safety Controller: FS1A  
 E-STOP: X series

c) When switching 32 scanning areas using an encoder

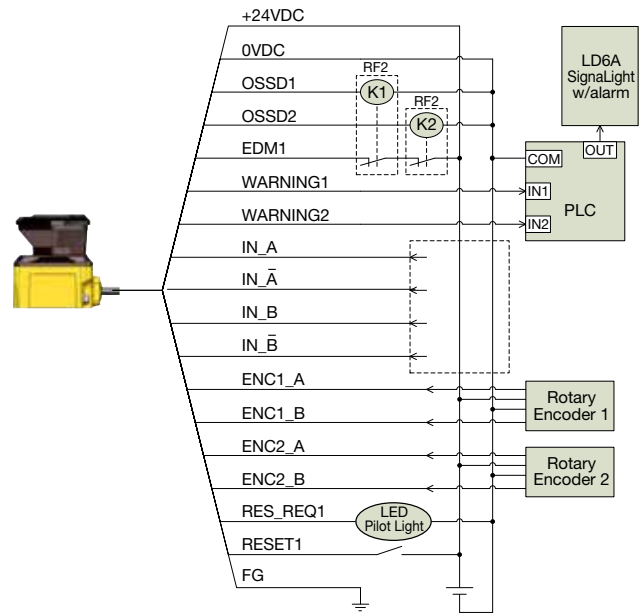

**IDEC safety products**  
 SignalLight w/alarm: LD6A  
 PLC: FC6A  
 LED pilot light: AP22  
 Force-guided relay: RF2

b) When using muting/override/EDM

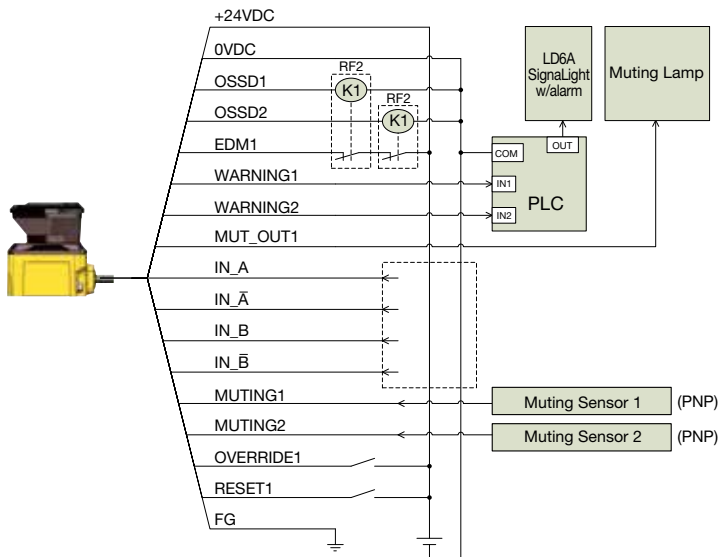

**IDEC safety products**  
 SignalLight w/alarm: LD6A  
 PLC: FC6A  
 Muting sensor: SA1E  
 Muting sensor lamp: HW1P-5  
 Force-guided relay: RF2

# SE2L Safety Laser Scanner

d) When using the master slave function to guard an AGV or robot

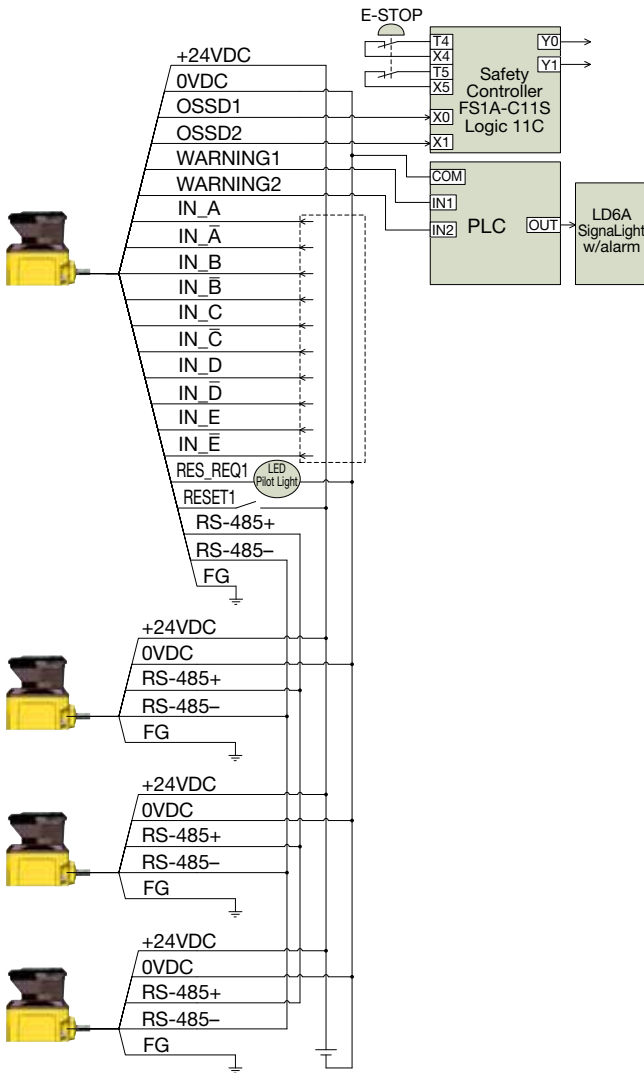

**IDEC safety products**  
 SignalLight w/ alarm: LD6A  
 PLC: FC6A  
 LED pilot light: AP22  
 Safety Controller: FS1A  
 E-STOP: X series

e) When using the master slave function to guard multiple hazards and perform partial stops

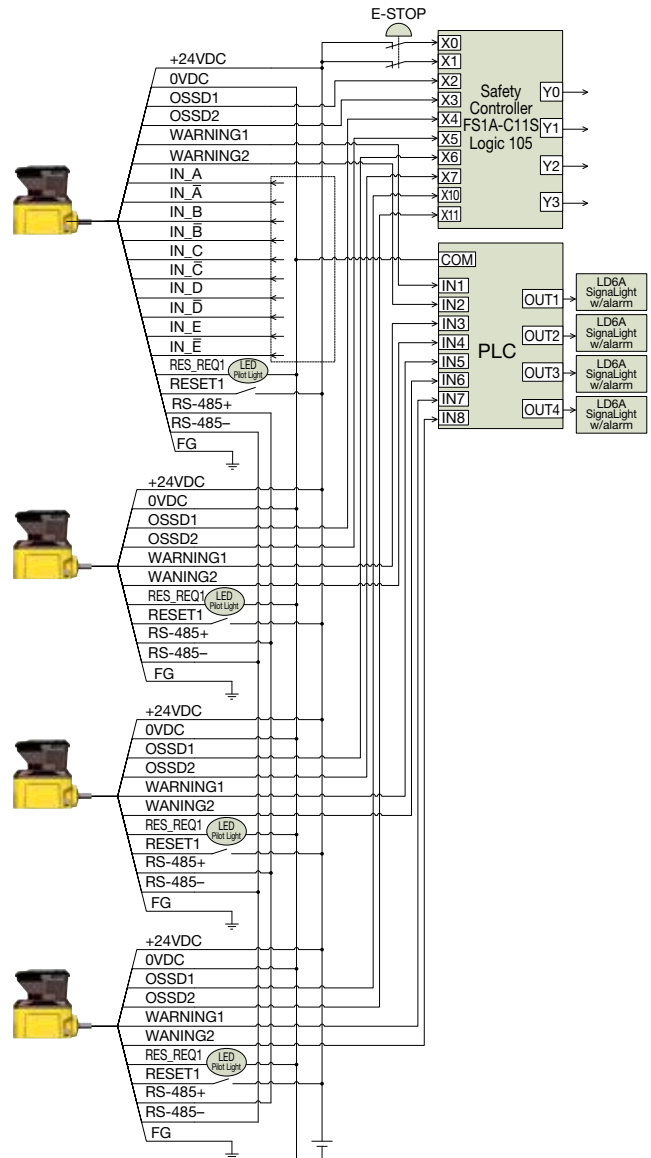

**IDEC safety products**  
 SignalLight w/ alarm: LD6A  
 PLC: FC6A  
 LED pilot light: AP22  
 Safety Controller: FS1A  
 E-STOP: X series

## Input/Output Circuit

### OSSD/WARNING Output Circuit

OSSD/WARNING outputs are N channel MOSFET outputs.

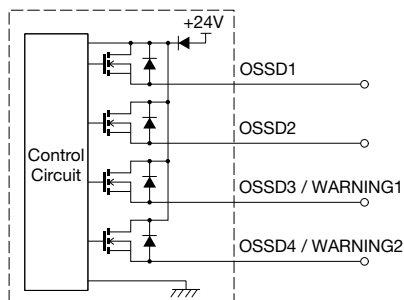

### Other Output Circuit

RES\_REQ1, RES\_REQ2, MUT\_OUT1, MUT\_OUT2 outputs are PNP outputs.

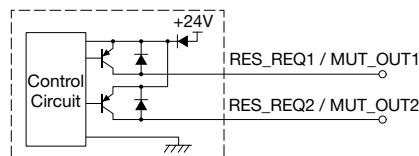

### Input Circuit

Available for are input, EDM1, EDM2, RESET1, RESET2, MUTING1, MUTING2, MUTING3, MUTING4, OVERRIDE1, and OVERRIDE2.

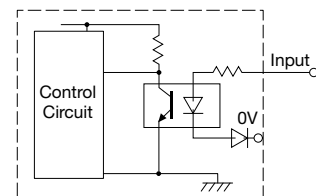

## Operating Principle

With the SE2L, the distance is measured by the Time of Flight (TOF) principle. The SE2L sends out very short pulses of infrared light. The mirror rotated by the motor sends the infrared light within the scanning range of 270°, and is reflected back from an object within the range.

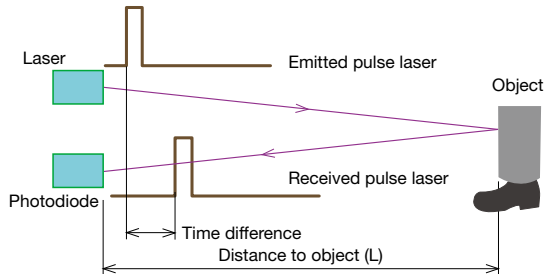

The distance can be calculated as follows:

$$L = \frac{1}{2} \times c \times T$$

L = Distance to the object  
 c = Speed of light  
 T = Time difference

## Scanning Area

A scanning area of the SE2L consists of:

- A protection + two zones
- A protection zone
- Two protection zones

Up to 32 sets of scanning areas can be configured. A software SLS Project Designer supplied with the SE2L is used to configure the protection and warning zones, providing excellent user interface. Automatic zone configuration by referring the boundary is also possible. See SE2L User's Manual "7. Function Configuration of SE2L" for details. The latest version of the software can be downloaded from IDEC website.

Protection zone: The area obtained by risk assessment and calculation of safety distance

Warning zone: The area to send alarms which can be set according to the application

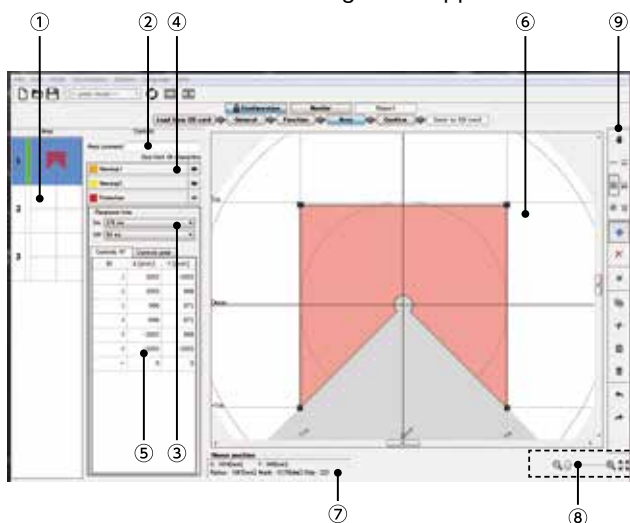

- ① Area preview
- ② Area comment
- ③ Response time (ON/OFF)
- ④ Area selection
- ⑤ Point coordinate
- ⑥ Area display
- ⑦ Mouse position
- ⑧ Zoom-in, zoom-out tool
- ⑨ Drawing tools bar

## Area Switching

The SE2L can store up to 32 area patterns. The number of maximum configurable areas depends on selected functions such as scan area mode and muting.

### Maximum number of patterns

Mode	Protection	Max. Internal Input	Max. Area	Max. Encoder Area
Standard	1	5	32	–
	2	5	32	–
EDN	1	4	16	–
	2	4	16	–
MUTING/EDM	1	2	4	–
	2	1	2	–
Encoder (Note 1)	1	2	3	32 (Note 2)

Note 1: Dual protection and muting function modes cannot be used when encoder input mode is selected.

Note 2: Among the four input patterns, at least one pattern must be used for encoder input. Other three remaining patterns can be selected to be used as a static input or not in use. A pattern with encoder input mode has up to 32 sets of area.

### Input combination for area switching

(ex. 5 inputs)

Area	IN_A	IN_B	IN_C	IN_D	IN_E	IN_Ā	IN_Ḃ	IN_Ĉ	IN_Ḍ	IN_Ē
1	ON	ON	ON	ON	ON	OFF	OFF	OFF	OFF	OFF
2	OFF	ON	ON	ON	ON	ON	OFF	OFF	OFF	OFF
3	ON	OFF	ON	ON	ON	OFF	ON	OFF	OFF	OFF
4	OFF	OFF	ON	ON	ON	ON	ON	OFF	OFF	OFF
5	ON	ON	OFF	ON	ON	OFF	OFF	ON	OFF	OFF
6	OFF	ON	OFF	ON	ON	ON	OFF	ON	OFF	OFF
7	ON	OFF	OFF	ON	ON	OFF	ON	ON	OFF	OFF
8	OFF	OFF	OFF	ON	ON	ON	ON	ON	OFF	OFF
9	ON	ON	ON	OFF	ON	OFF	OFF	OFF	ON	OFF
10	OFF	ON	ON	OFF	ON	ON	OFF	OFF	ON	OFF

- See User's Manual for more combinations (max. 32 areas)



# SE2L Safety Laser Scanner

## Response Time

The OFF response time (default: 60ms) for the OSSD signal and ON response time (default: 270ms) can be configured by using the SLS Project Designer. The response time for WARNING 1, 2 is the same as the response time for OSSD. In dual protection mode, different response time can be set for protection zone 1 and 2 each. The stability of the SE2L can be increased by setting a long response time, but a long safety distance is required (see User's Manual 4. Application Examples of SE2L). Before setting the response time, the user must perform a risk assessment thoroughly. The configurable response time is shown in the table below. Be sure to add the time taken to switch areas (30 ms).

## Time Chart

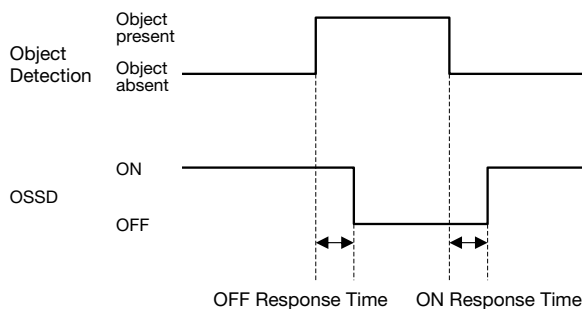

## SE2L Response Time

	Response Time (ms)							
OFF (ON→OFF)	60	90	120	150	180	210	240	270
	300	330	360	390	420	450	480	510

	Response Time (ms)							
ON (OFF→ON)	-	-	-	-	-	-	-	270
	300	330	360	390	420	450	480	510

- Default value
- Minimum configurable response time in Master/Slave mode  
OFF: 120ms, ON: 300ms

## Safety Distance

### Access protection

In this application, the SE2L is horizontally installed to protect the hazardous area. The protection zone is set around the hazardous area to prevent humans or objects from entering the hazardous area. Warning zones 1 and 2 are configured to surround the protection zone.

### Protection zone 1 application (horizontal, stationary installation)

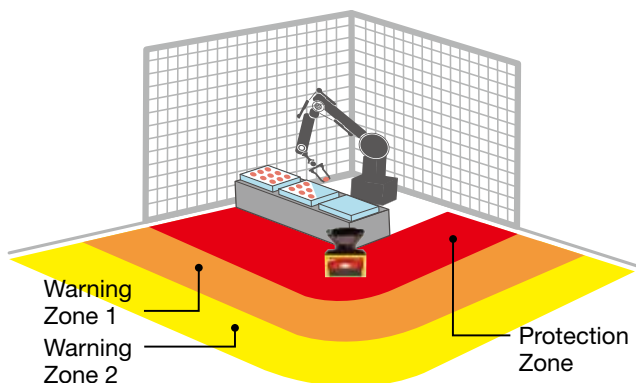

Warning zones 1 and 2 are set around the protection zone to send alarms to prevent humans or objects from entering the hazardous area and stopping the machine. By detecting humans or objects in the protection zone, the OSSD signal switches from ON to OFF. Also, when humans or objects are detected in the warning zone, WARNING signal switches from ON to OFF.

### Upper view (stationary)

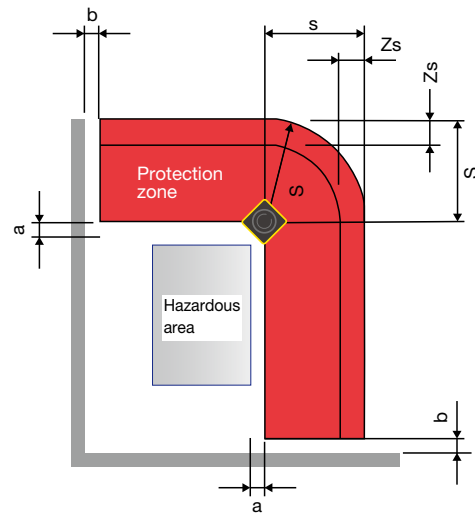

- Maintain the distance "a" shorter than the minimum detection width. To prevent unwanted detection, maintain the distance "b" 100mm.

### Side view (stationary)

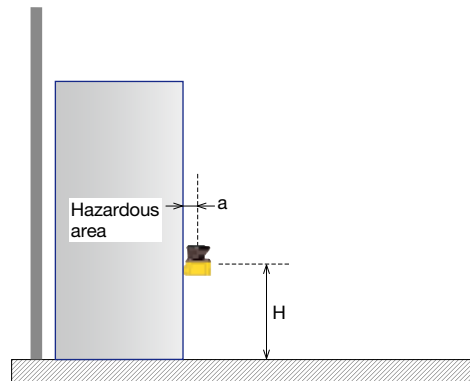

### Calculation

$$S = (K \times (T_m + T_s) + C + Z_s)$$

S = Safety distance (mm)

K = Human approach speed 1,600 (mm/s)

$T_m$  = Maximum stop speed of machine or system (s)

$T_s$  = Response time of SE2L (s)

$C = 1200 - 0.4 \times H \geq 850$

H = height from the floor to the sensing plane (mm)

$1000 \geq H \geq 15 \times (d - 50)$

d = Minimum sensing width of object (mm)

$Z_s$  = Additional safety distance of SE2L (mm)

- See User's Manual for access protection and area protection (access detection, collision avoidance for mobiles)

## Installation

### Light Interference

SE2L is a sensor that transmits pulsed laser for obstacle detection. Interfering light sources may lead to false detection. Before using the SE2L, examine the surrounding environment. If the SE2L must be used under the environment shown below, install the SE2L so that the light source is located more than  $\pm 5$  degrees from the sensing plane to prevent light interference.

- a) Incandescent light
- b) Florescent light
- c) Strobe light
- d) Flashing beacon
- e) Sunlight
- f) Infrared light source

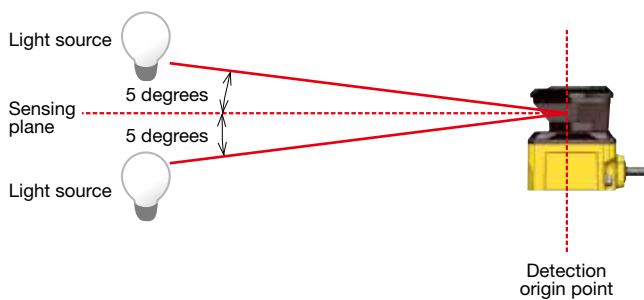

### Mutual Interference

When using several safety laser scanners or scanning range finders of the same model, pulse laser signals from other sensors may be falsely detected. To prevent mutual interference, see the installation methods shown below. See User's Manual for more details.

#### 1) Changing the installation height

Install the SE2Ls at different heights to keep at least 5 degree distance between the detection planes.

##### ① Face to face installation

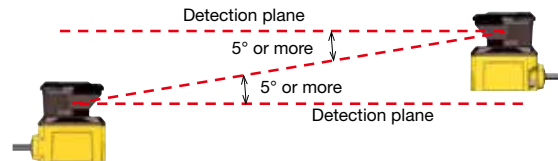

##### ② Parallel installation

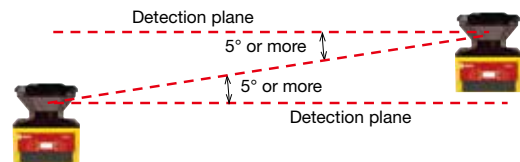

#### 2) Changing the installation angle

Adjust the angle of SE2Ls to keep at least 5 degree distance between the detection planes.

##### ① Face to face installation

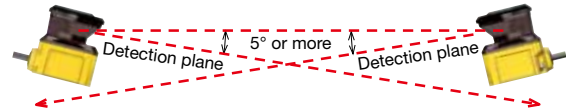

##### ② Parallel installation

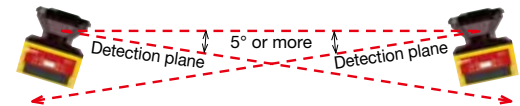

#### 3) Using shields

Install a shield between the SE2Ls to prevent prevent the laser beams from entering the other SE2L.

##### ① Face to face installation

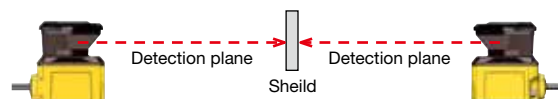

##### ② Parallel installation

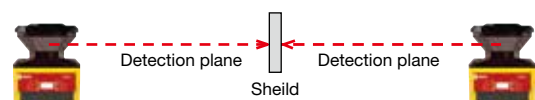

# SE2L Safety Laser Scanner

## Highly Reflective Background

Highly reflective backgrounds may cause false detection causing the SE2L to detect a longer distance than the actual distance. If an operating environment with a highly reflective background cannot be avoided, an additional distance of 200 mm, in addition to the 100mm additional safety distance, is needed when configuring protection or warning zones.

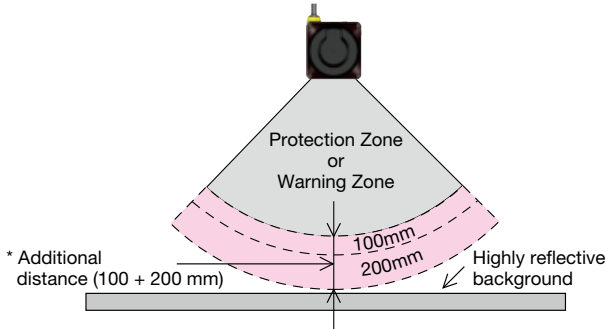

\* Additional distance: the distance required to operate the SE2L under high reflective background

## Limited Detection Capability Area

The limited detection capability area is the area between the optical window and the beginning of the detection zone. The area from the origin point of the SE2L to 90 mm from the origin point is the limited detection capability area. In this area, a low reflective object is difficult to detect.

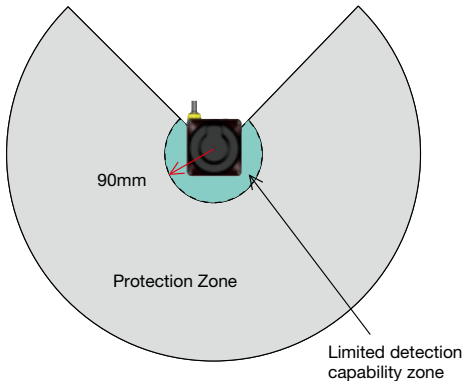

## Wiring

The table below shows the functions of each wire. Use of a shielded wire is recommended.

### Wire Color and Functions

Color	Signal	Function	Description	AWG	Pin No.	
Brown	+24V DC	Power	Power: 24V DC	22	1	
Blue	0V DC		Power: 0V DC	22	2	
Red	OSSD 1	Output	Protection zone output 1	26	3	
Yellow	OSSD 2		Protection zone output 2	26	4	
Red/Black	OSSD 3 WARNING1	Output	Protection zone output 3 Warning zone output 1	28	5	
Yellow/Black	OSSD 4 WARNING2		Protection zone output 4 Warning zone output 2	28	6	
Purple	IN_A	Input	Area switching input A	28	7	
Gray	IN_B MUTING3		Area switching input B Muting input 3	28	8	
White	IN_C OVERRIDE1 ENC1_A		Area switching input C Override input 1 Encoder input 1_A	28	9	
Pink	IN_D MUTING1 ENC1_B		Area switching input D Muting input 1 Encoder input 1_B	28	10	
Green	IN_E EDM1		Area switching input E External device monitoring 1	28	11	
Purple/Black	IN_A̅		Area switching input A̅ invert	28	12	
Gray/Black	IN_B̅ MUTING4		Area switching input B̅ invert Muting input 4	28	13	
White/Black	IN_C̅ OVERRIDE2 ENC2_A		Area switching input C̅ invert Override input 2 Encoder input 2_A	28	14	
Pink/Black	IN_D̅ MUTING2 ENC2_B		Area switching input D̅ invert Muting input 2 Encoder input 2_B	28	15	
Green/Black	IN_E̅ EDM2		Area switching input E̅ invert External device monitoring 2	28	16	
Yellow/Green	RESET1		Reset input 1	28	17	
Yellow/Blue	RESET2		Reset input 2	28	18	
Orange	RES_REQ1 MUT_OUT1		Output	RES_REQ1: request output 1 MUT_OUT1: muting state output 1	28	19
Orange/Black	RES_REQ2 MUT_OUT2			RES_REQ2: request output 2 MUT_OUT2: muting state output 2	28	20
White/Blue	RS-485+		Communication	Communication protocol RS-485 (twisted pair)	28	21
White/Red	RS-485-			Communication protocol RS-485 (twisted pair)	28	22
Shield	FG	—	Frame ground	—	Case	

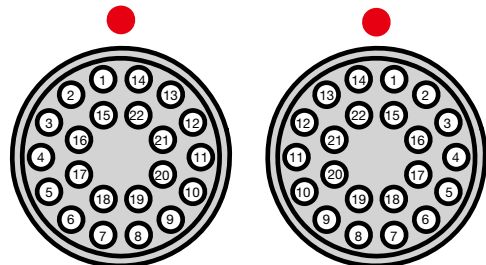

SE2L-H05LPC  
Pin No.

SE9Z-HSC-C□□□  
Socket No.



## OSSD

In SE2Ls, the OSSD signal has a self-diagnosis function that tests the signal periodically to detect malfunction. The OSSD signal will turn OFF when an error is detected due to the self-diagnosis function. The self-diagnosis function of the OSSD detects abnormality by switching off OSSD 1 to OSSD 4 at intervals of 300  $\mu$ s maximum. Be sure to use a force-guided relay, converter, or controller that does not respond to this self-diagnosis function.

## Time chart

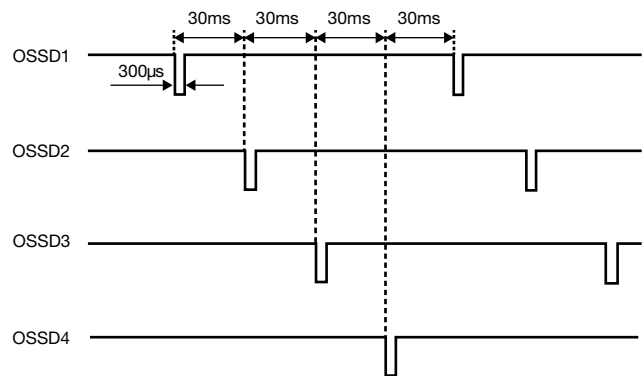

## Safety Precautions

For correct use of the SE2L, take note of the following precautions.

- SE2L is a AOPDDR (Active Optoelectronic Protective Device responsive to Diffuse Reflection) that detects diffused emitted light within the protection zone.
- Perform tests before operation to check the function and performance of the SE2L.
- SE2L is designed to protect human beings or systems by monitoring the hazardous area. It is not designed for the protection from high speed objects or electromagnetic radiation.
- To maintain the degree of protection and to prevent injury or death, do not modify or disassemble the SE2L.
- IDEC does not warrant any problems that were caused by modification or disassembly of the SE2L.
- The operator must be a person qualified to operate the SE2L. The operator must be trained and be able to operate the SE2L correctly.
- The administrator must provide continuous training to the operator for correct use of the SE2L.
- The administrator must understand the user's manual and be responsible for ensuring appropriate operating conditions for SE2L.
- SE2L has been manufactured and shipped under strict quality control. If you find any defect in the product, contact distributor or sales representative.
- IDEC does not take responsibility for damage caused by improper use of the product by customers or third parties. IDEC cannot take responsibilities for any loss from the misuse except for the responsibilities governed by law.
- To examine the object detecting performance, use a test piece the size equivalent to the minimum detectable object.
- Error occurs when detection capability is below 30% due to homogenous dirt on the optical window. The operator must keep the windows clean.
- When the interlock function is active, make sure that the surrounding environment, especially within the protection zone, is safe before resetting the interlock.
- While SE2L is removed, a protective measure must be taken to ensure safety within the protection zone. To prevent entry into the danger zone, use protective materials such as a safety guard or light curtain.
- SE2L and its accessories are subject to change for improvement without prior notice.
- Dispose the SE2L as industrial waste or in accordance with the local regulations.

## Operating Environment

- Make sure that the operating environment is within the range of the specifications (temperature, humidity, light interference) described in User's Manual, otherwise malfunction or degradation of detection performance may result.
- Do not use the SE2L near a machine that may generate strong radio waves. It may interfere with the operation of the SE2L.
- Do not use or install the SE2L where dust, smoke, or corrosive chemical substances exist. Using the SE2L under these environments may lead to degradation of detection performance.
- The SE2L is for indoor use only.

## Installation

- Install the SE2L on a stable surface or structure to prevent displacement of the sensor.
- Install the SE2L securely so that screws do not loosen due to shock or vibration. (Recommended tightening torque 3 N·m). Displacement may degrade protection performance.
- Determine the safety distance before installing the SE2L. After installing the SE2L, use a test piece for all protection zones to check the sensing functions.
- After installing the SE2L, use protective materials such as safety guards and light curtains to prevent entry into the protective zone.
- The following switches must be installed far from the protection zone, so that the operator can operate the switches while overseeing the entire protection zone.
  - \* Switch to reset the interlock function
  - \* Switch to start muting function
  - \* Switch to start override function
- If several SE2Ls are installed on the same sensing plane, mutual interference may occur.
- Provide enough space for installation and maintenance of the SE2L.
- Do not cover the front of the optical window with glass or transparent cover, otherwise detection characteristics of the SE2L may be impaired.
- Minimum sensing width differs according to the distance.