

Datasheet SFM3003 series

Digital Mass Flow Meter



Product Summary

Sensirion's SFM3003 is a versatile, low pressure drop, bidirectional flow meter. Based on the same form factor as the proven SFM3000 series, SFM3003 comes with a larger flow range of up to 300slm and offers additional features for measuring flows of air, oxygen and mixtures of air and oxygen. SFM3003 series is the ideal choice for medical and industrial applications.

Key characteristics at a glance

- Flow range up to 300slm
- Calibrated for O₂, air and mixtures thereof
- I²C interface
- Low pressure drop across the sensor
- No recalibration needed
- Bi-directional option up to -150slm

Benefits of Sensirion's CMOSens® Technology

- High reliability and long-term stability
- Best signal-to-noise ratio
- Industry-proven technology with a track record of more than 15 years
- Designed for mass production
- High process capability
- Scalability

Content

1. Ordering Information	2
2. Specifications	2
3. Measurement Mode	5
4. Digital Interface Description	7
5. Package Outline	14
6. Shipping Package	14
7. Revision History	14
8. Important Notices	15

1. Ordering Information

Use the part names and item numbers shown in the following table when ordering the SFM3003. For the latest product information and local distributors, visit www.sensirion.com.

Part name	Description	Order number
SFM3003-300-CL	-30 to 300 slm range, with cap, low pressure drop (only one mesh at inlet)	3.000.386
SFM3003-300-CE	-150 to 300 slm range, with cap, extended negative flow range	3.000.474

2. Specifications

2.1 Flow Specification¹

Parameter	Condition	SFM3003-300-CL		SFM3003-300-CE		Units
Measurement range ²		Air/O ₂ : -30 to 300		Air/O ₂ : -150 to 300		slm ³
		Typ. ⁴	Max. ⁵	Typ. ⁴	Max. ⁵	
Accuracy ⁶	Span (200...300slm)	±2.5%	±3.5%	±3%	±4%	m.v. ⁷
	Span (-30...200slm)	±2%	±2.5%	±2.5%	±3%	m.v. ⁷
	Span (-150...-30slm)	n/a	n/a	±2.5%	±3%	m.v. ⁷
	Zero point	±0.05	±0.1	±0.05	±0.1	slm ³
Noise Level ^{6, 8}	Span (200...300slm)	±1.5%	±2%	±1.5%	±2.5%	m.v. ⁷
	Span (-30 ...200slm)	±1.0%	±1.5%	±1.0%	±2%	m.v. ⁷
	Span (-150 ...-30slm)	n/a	n/a	±1.0%	±2%	m.v. ⁷
	Zero point	±0.05	±0.1	±0.05	±0.15	slm ³
Span shift due to temperature variation		< 0.5% of reading per 10°C				
Flow step response time (τ ₆₃)		< 3ms				
Resolution		16 bit				
Calibrated for		O ₂ , Air and mixtures of Air/O ₂				
Media compatibility		Air, N ₂ , O ₂ , non-condensing				
Pressure Drop @60slm @200slm @300slm	Measured with air	One mesh: < 80 / < 0.32 < 500 / < 2.0 < 750 / < 3.0		Two meshes: < 100 / < 0.4 < 600 / < 2.4 < 1200 / < 4.8		Pa / inH ₂ O

¹ Unless otherwise noted, all sensor specifications are valid at 25°C with VDD = 3.3 V and absolute pressure = 966 mbar and horizontal flow direction.

² For other ranges contact Sensirion

³ Mass flow measured in liters per minute at standard conditions (T = 20°C and p = 1013 mbar)

⁴ For "Typ" a CpK of 0.67 is targeted (95% of sensors within the Typ limit)

⁵ for "Max" no sensor measured outside of these limits will be shipped and a CpK of 1.33 is targeted

⁶ Span or offset value, whichever is larger

⁷ Measured value

⁸ Noise Level is defined as standard deviation of individual sensor readings, measured in "average till read" mode with readout every 3ms, "Typ.": average of noise level, "Max." > 99% of sensors have a noise level below indicated value

2.2 Temperature Specification¹

Parameter	Value
Measurement range	-20 °C to +85 °C
Resolution	16 bit
Accuracy	±2°C for range -10 °C to +60 °C, ±3°C otherwise
Repeatability	0.1°C

2.3 Electrical Specifications

Parameter	Symbol	Condition	Min.	Typ.	Max	Units	Comments
Supply Voltage	V _{DD}		2.7	3.3	5.5	V	Recommended: 3.3V +/- 5% (calibration voltage)
Power-up/down level	V _{POR}		2.3	2.5	2.7	V	
Supply current	I _{DD}	Measuring		3.8	5.5	mA	VDD 3.3V
		Idle state			1.1	mA	
		Sleep mode			1	µA	

2.4 Timing Specifications

Parameter	Symbol	Min.	Typ.	Max.	Units	Comments
Power-up time	t _{PU}		2		ms	Time to sensor ready
Soft reset time	t _{SR}			2	ms	Time between soft reset command or exit sleep mode and sensor ready
Warm-up time	t _w		30		ms	To reach accuracy spec after first measurement command
I ² C SCL frequency	f _{I2C}		400	1000	kHz	
Update rate flow value		1800	2000	2200	Hz	
Update rate temperature value		112.5			Hz	Temperature value is updated at least every 16 flow values

¹ The measured temperature is the temperature of the bulk silicon in the sensor. This temperature value is not only depending on the gas temperature, but also on the sensor's surroundings. Using the signal to measure solely the gas temperature will need special precautions, such as isolating the sensor from external temperature influences.

2.5 Mechanical Specifications

Parameter	Symbol	Min.	Typ.	Max.	Units	Condition/Comment
Operating pressure range		0.7		1.3	bar	absolute
Allowable overpressure	P_{max}	-0.2		0.2	bar	gauge
Rated burst pressure	P_{burst}			>1	bar	gauge
Weight	m		14.6		g	

2.6 Materials

Parameter	
Wetted materials	PPE+PS blend, Si, glass (Si ₃ N ₄ , SiO _x), gold, FR4, copper alloy, lead-free solder, epoxy, polyurethane, stainless steel (annealed)
REACH, RoHS	REACH and RoHS compliant

2.7 Absolute Minimum and Maximum Ratings

Parameter	Rating	Units
Supply Voltage V_{DD}	-0.3 to 5.5	V
Max Voltage on pins (SDA, SCL)	-0.3 to $V_{DD}+0.3$	V
Input current on any pin	± 70	mA
Operating temperature range ¹	-20 to +85	°C
Storage temperature range	-20 to +85	°C
Max. humidity for long term exposure	40	°C dew point
ESD HBM (human body model)	2	kV

2.8 Pin Assignment

The pin assignments of the SFM3003 series can be found in Table 1. The cap of the SFM3003 is compatible with DuraClik™ Wire-to-Board Receptacle Housing, Single Row, 4 Circuits. (Molex product number: 502351-0400).

Name	Description
SCL	Serial Clock (I ² C Interface)
VDD	VDD Supply
GND	Connect to ground
SDA	Bidirectional Serial Data (I ² C Interface)

digital:

Table 1: SFM3003 series pin assignment

¹ For Air and N₂. Long term exposure to (high concentrations of) O₂ at high temperatures can reduce the product lifetime

3. Measurement Mode

After the sensor receives a “start continuous measurement” command (for more details see Section 4.3.1) it enters the corresponding measurement mode and continuously performs a measurement every ~0.5ms. Therefore, a new reading can be obtained every 0.5ms. A single reading consists of three measurement values: flow, temperature, and one value for a status word (for more details on status word see Section 4.3.2).

3.1 Averaging of Flow Value

Two modes for on-sensor averaging of the flow signal are available:

- 1) Average-until-read: in this mode, the sensor averages all measured values prior to read out. This averaging mode is the default mode selected upon startup and after a reset.
- 2) Fixed-N averaging: in this mode, every reading is the average of a fixed number (N) of measured flow values.

3.1.1 Average-Until-Read

If the ‘average till read’ option is chosen, the sensor averages all values x_i prior to the read out. This has the benefit that the user can read out the sensor at his own desired speed, without losing information and thus preventing aliasing. During the first 64ms of averaging, the averaged value is obtained as the arithmetic mean:

$$\bar{x} = \sum_{i=1}^M \frac{x_i}{M} \quad \text{for } t < 64 \text{ ms}$$

If the period between readouts is longer than 64ms, the sensor will continue to average, but using a different algorithm. In this algorithm, exponential smoothing is used with a smoothing factor $\alpha = 0.02$:

$$S_k = \alpha \cdot x_k + (1 - \alpha) \cdot S_{k-1}, \quad S_0 = \bar{x}, \quad \text{for } t > 64 \text{ ms}$$

Where S_0 is the arithmetic mean value after the first 64ms and the readout value for flow is S_k .

With an exponential smoothing factor of $\alpha = 0.02$, the value read out by the user is an average value of about the last 64ms. In order not to lose information, it is recommended to read out the sensor at least once every 64ms. Please refer to the relevant literature for more information about exponential smoothing.

Average-until-read is the default averaging mode after startup and after a reset. It can further be selected by the user by setting $N=0$ in the argument for the “Configuration of Averaging” command (for more details see Section 4.3.5).

3.1.2 Fixed-N Averaging

Averaging may also be set to a fixed number $1 \leq N \leq 128$ of measurements to be averaged (c.f. Section 4.3.5). This type of averaging is especially suited to avoid any averaging ($N=1$). If fixed-N averaging is chosen, the update time for new readings is $N \cdot 0.5\text{ms}$ accordingly. Averaging has the benefit that the user can read out the sensor at his own desired speed, without losing information and thus preventing aliasing. In this case, the averaged value \bar{x} is the arithmetic mean of the individual, ~2kHz measurements x_i :

$$\bar{x} = \sum_{i=1}^N \frac{x_i}{N}$$

If no averaging is desired, set N to 1.

3.2 Sensor Start-Up and Warm-Up Behavior

The typical time for system power-up (until the sensor responds to communication requests) is 2ms. The typical time from a soft reset until the sensor responds to communication requests is also 2ms if the SCL line is high.

After reset or start-up of the sensor, the sensor's internal heater is off and is automatically turned on by performing a *Start Continuous Measurement* command (see Section 4.3.1). The very first measurement after *Start Continuous Measurement* is ready after approximately 12ms.

Due to the thermal measurement principle, a total warm-up time of typically 30ms is necessary for an accurate measurement. This includes the 12ms needed for measurement initialization.

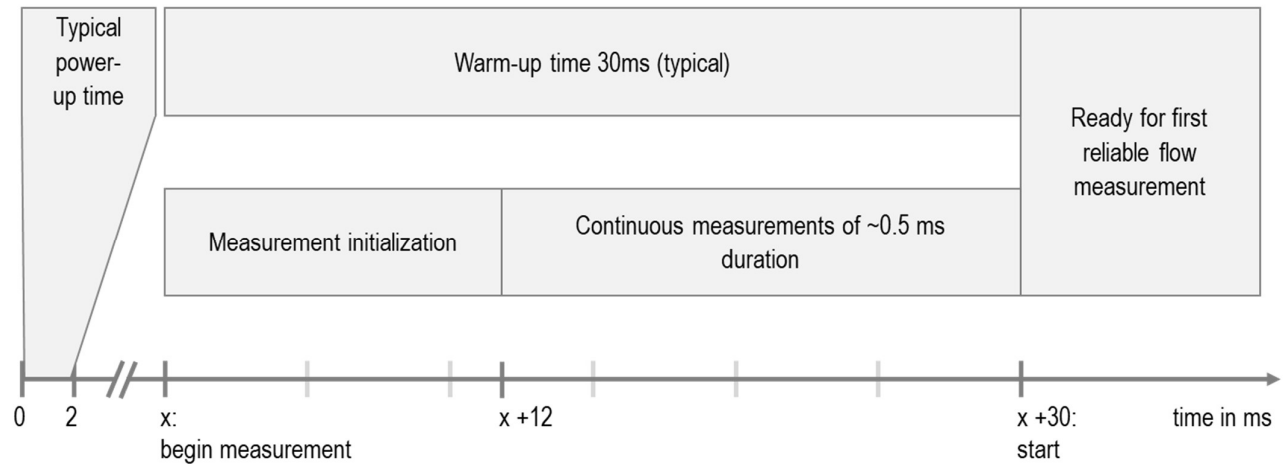

Figure 1: Time diagram upon start-up.

3.3 Sensor Check at Start-Up

The gas flow sensor checks the integrity of its entire memory content (including all lookup tables for all gases and gas mixtures and the entire configuration) at start-up automatically using a CRC check sum. In case the CRC check fails, the I²C-interface is deactivated.

The following command provides a further possibility for an integrity check: Read Product Identifier (command code 0xE102, see Section 4.3.9). Ideally suited to test if the sensor is connected correctly and if the sensor has been assigned the correct I²C-address upon start-up.

4. Digital Interface Description

The sensor's digital interface is compatible with the I²C protocol. This chapter describes the available command set. For detailed information about the I²C protocol, please consult the document "NXP I²C-bus specification and user manual" (http://www.nxp.com/documents/user_manual/UM10204.pdf).

The physical interface consists of two bus lines: a data line (SDA) and a clock line (SCL) which need to be connected via pull-up resistors to the bus voltage of the system.

4.1 I²C Address

The I²C address for different SFM3003 versions are:

Product Version	I ² C address (hex)	I ² C address (binary)
SFM3003-300-CL	0x28	b0101000
SFM3003-300-CE	0x2D	b0101101

Table 2: I²C addresses of the SFM3003 series

In the I²C protocol, a read or write bit follows the I²C address.

4.2 I²C Sequences

The commands have a length of 16 bits. If commands require an argument, they are followed by a 16-bit argument plus an 8bit checksum:

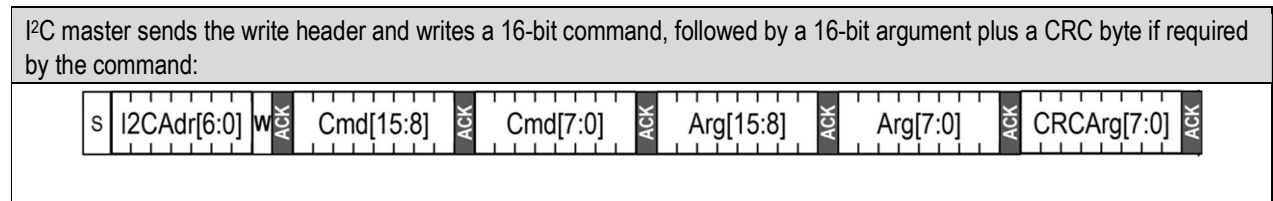

Figure 2: I²C sequences to send a command with an argument to the sensor.

After that, data is read from the sensor in multiples of 16-bit words, each followed by an 8-bit checksum to ensure communication reliability. I²C sequences can be aborted with a NACK and STOP condition as indicated below.

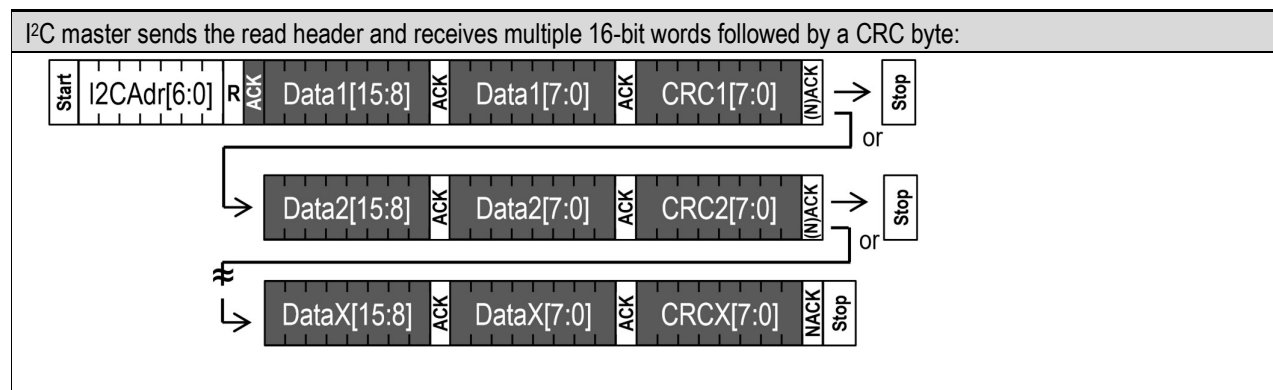

Figure 3: I²C sequences to read results from the sensor. Dark areas with white text indicate that the sensor controls the SDA (Data) line

4.3 I²C Commands

The command set consists of a set of various commands, which are described in the following sections:

- Various Start continuous measurement commands (one for each gas/gas mixture)
- Update concentration
- Stop continuous measurement command
- Configuration of averaging
- Read Scale Factor, Offset, and Flow Unit
- Soft reset
- Entering and exiting sleep mode
- Read product identifier

4.3.1 Start Continuous Measurement and Read Results

The sensor measures both flow and temperature and provides in a third data buffer a status word. All three measurement results can be read out through one single I²C read header when the continuous measurement is running. The specific command code used for the start continuous measurement command selects the calibrated gas or binary gas mixture (lookup table) for the flow signal.

Command code (Hex)	SFM3003	Command argument	Averaging
0x3603	Gas 0: O ₂	N/A	According to Section 4.3.5
0x3608	Gas 1: Air	N/A	
0x3615	Reserved for future use	N/A	
0x361E	Reserved for future use	N/A	
0x3624	Reserved for future use	N/A	
0x362F	Reserved for future use	N/A	
0x3632	Gas mixture 0: Air-O ₂	Volume fraction of O ₂ (in ‰)	

Table 3: I²C commands to start continuous measurement

After the command has been sent, the chip continuously measures and updates the measurement results. New results (flow, temperature, and status word) can be read continuously with a single I²C read header for each measurement.

Further commands must not be sent until the stop measurement command has been sent. Consult section 4.3.4 for more details.

After the start measurement command is sent:

- the first measurement result will be available after 12ms
- small accuracy deviations (few % of reading) can occur during the first 30ms (including the 12ms)

If an I²C read header (I²C address + read bit) is sent to the sensor when no measurement data is available, the sensor will respond with a NACK condition.

Preceding command	Consecutive read	Description
Continuous measurement	Byte1: Flow 8msb Byte2: Flow 8lsb Byte3: CRC Byte4: Temp 8msb Byte5: Temp 8lsb Byte6: CRC Byte7: Status Word 8msb Byte8: Status Word 8lsb Byte9: CRC	After a start continuous measurement command, the measurement results can be read out. The temperature and the consecutive bytes don't need to be read out (every time). The read sequence can be aborted by a NACK and a STOP condition.

Table 4: Consecutive reads after I²C command to start continuous measurement. The flow and temperature values are raw data value consisting of a 16bit signed integer. For conversion into physical units refer to Section 4.5.

4.3.2 Status Word

The status word is returned along with every flow and temperature measurement. It contains the measurement command that is currently running, information on the currently selected averaging mode, and the defined gas concentration of the current measurement command (either a fixed value of 0x3FF for a pure calibration gas, or the volume fraction of O₂ in per mille for gas mixtures). The table below lists the values returned by the status word.

Measurement Mode	Status Word (bits 15:0)			
	Bits <15:12>: currently running measurement command	Bit <11>: status of exponential smoothing	Bit <10>: averaging mode	Bits <9:0>: concentration
0x3603	0b0000	0: Exponential smoothing is not active 1: Averaging mode has switched to exponential smoothing	0: Average-Until-Read is active 1: Fixed-N averaging is active	Fixed value of 0b11111111 = 0x3FF = 1023 to indicate that a pure calibration gas is being measured
0x3608	0b0001			
0x3615	0b0010			
0x361E	0b0011			
0x3624	0b0100			
0x362F	0b0101			
0x3632	0b0110			
0x3639	0b0111			
0x3646	0b1000			Volume fraction of Gas 0 (in ‰)

Table 5: Values returned by the status word depending on the measurement command running. Rows, which are grayed out are reserved for future uses.

4.3.3 Update Concentration

To update the concentration of a binary gas mixture dynamically, i.e. without interrupting the running measurement mode, an I²C transmission sequence consisting of a set of two instructions is provided:

Command	Command code (Hex)	Command argument	Description
Transmit concentration	0xE17D	Volume fraction of Gas 0 in ‰	This instruction transmits the concentration value to the flow sensor.
Reset I ² C address pointer	0xE000	None	This instruction resets the I ² C address pointer to the regular result output buffer such that the measurement data as described in Sections 4.2 and 4.3 are obtained upon a subsequent read header.

Table 6: I²C commands to update the concentration for binary gas mixtures.

After those two commands changing the gas concentration, measurement results can be read with a read header as described in Section 4.3.1. No new start command is required.

Please note:

- The concentration value must not be updated more than once per millisecond.
- If a concentration value greater than 1000 is passed to the sensor, the measurement mode will stop.
- For the initial concentration value, which is supplied with the start measurement command (0x3632, c.f. Sec. 4.3.1), the command argument will be immediately applied without a need to send the second command.

Attention: Changing the gas mixture by using a new measurement command takes 12 ms to change the concentration. Therefore, the procedure to change the concentration only is significantly faster and should be used for dynamic adjustments of the concentration.

Important: During the transmission and execution of these two commands (in Table 6) no I²C-read must take place.

4.3.4 Stop Continuous Measurement

Command	Command code (Hex)	Description
Stop continuous measurement	0x3FF9	This command stops the continuous measurement and puts the sensor in idle mode. After it receives the stop command, the sensor needs up to 0.5ms to power down the heater, enter idle mode and be receptive for a new command.

Table 7: I²C command to stop continuous measurement.

When the sensor is in continuous measurement mode, the sensor must be stopped before it can accept another command.

The only exceptions are the soft reset (see Section 4.3.7) command and the update concentration command (see Section 4.3.3).

In idle mode the sensor will consume less power but consider the sleep mode for most effective energy saving results.

4.3.5 Configuration of Averaging

Command	Command code (Hex)	Command argument	Description
Configure averaging	0x366A	<i>N</i>	This command configures the sensor's averaging mode: 1) $N=0$ (default): average-until-read mode (c.f. Section 3.1) 2) $1 \leq N \leq 128$: fixed- <i>N</i> averaging mode. <i>N</i> is the number of internal measurements that are averaged for one returned measurement value (i.e. the average over <i>N</i> flow samples, where $N = \text{CmdArgument}$, c.f. Section 3.1). The configured averaging mode will be used for flow measurements until a reset or re-execution of this command is performed. After a reset, averaging is set to average-until-read mode (i.e. <i>N</i> is set to 0). The highest averaging number allowed is 128. If a higher number is used in the command argument, it will be overruled by the maximal value of 128 samples to average. If no averaging is desired, set <i>N</i> to 1.

Table 8: I²C command to configure averaging.

4.3.6 Read Scale Factor, Offset, and Flow Unit

This command provides the scale factor and offset to convert flow readings into physical units (see Section 4.5). The scale factor and offset are specific to the calibrated gas / gas mixture and its corresponding lookup table used for the flow

measurement. Therefore, the gas / gas mixture needs to be specified in the command argument by the command code of the corresponding start continuous measurement (see Section 4.3.1).

For the SFM3003 series, the flow unit is a fixed value 0x0148 and corresponds to slm: standard liter per minute at 20°C and 1013mbar pressure.

Command	Command code (Hex)	Command argument (Hex)
Read Scale Factor, Offset, and Flow Unit	0x3661	Command code of desired gas / gas mixture for scale factor, offset and flow unit (Section 4.3.1). The command argument needs to be followed by CRC (Section 4.2)

Preceding command	Consecutive read	Description
Read Scale Factor, Offset, and Flow Unit	Byte1: Scale factor 8msb Byte2: Scale factor 8lsb Byte3: CRC Byte4: Offset 8msb Byte5: Offset 8lsb Byte6: CRC Byte7: Flow Unit 8msb Byte8: Flow Unit 8lsb Byte9: CRC	After a "Read Scale Factor, Offset, and Flow Unit" command, the corresponding results can be read out. The scale factor and offset are a 16-bit signed integer number represented by a two's complement (ranging from -32'768 to 32'767). The flow unit is a 16-bit identifier.

Table 9: I²C command to read the scale factor, offset, and flow unit. Result of this command.

4.3.7 Soft Reset

Command	I ² C address + W bit + command code (Hex)	Consecutive read	Description
General call reset	0x0006	NA	This sequence resets the sensor with a separate reset block, which is as much as possible detached from the rest of the system on chip. <u>Note that the I²C address is 0x00, which is the general call address, and that the command is 8 bits long.</u> The reset is implemented according to the I ² C specification.

Table 10: Reset command

After the reset command the sensor will typically take 2ms to reset. During this time, the sensor will not acknowledge its address nor accept commands.

4.3.8 Entering and Exiting Sleep Mode

In sleep mode the sensor uses a minimum amount of power. The mode can only be entered from idle mode, i.e. when the sensor is not performing measurements.

This mode is particularly useful for battery operated devices. To minimize the current in this mode, the complexity of the sleep mode circuit has been reduced as much as possible, which is mainly reflected by the way the sensor exits the sleep mode. In sleep mode the sensor cannot be soft reset.

Command	Command code (Hex)	Consecutive read	Description
Enter Sleep mode	0x3677	NA	The sleep command can be sent after a stop continuous measurement command has been issued and the sensor is in idle mode.

Exit Sleep mode	NA	NA	The sensor exits the sleep mode and enters the idle mode when it receives the valid I²C address and a write bit ('0') . Note that the I ² C address is not acknowledged. It is necessary to poll the sensor to see whether the sensor has received the address and has woken up. This should take typically 16ms.
-----------------	----	----	--

Table 11: Sleep mode commands

4.3.9 Read Product Identifier

The product identifier and the serial number can be read out by sending the command below. The command can only be entered from the idle mode, i.e. when the sensor is not performing measurements

Command	Command code (Hex)	Consecutive read	Description
Read product identifier	0xE102	Byte1: Product number [31:24] Byte2: Product number [23:16] Byte3: CRC Byte4: Product number [15:8] Byte5: Product number [7:0] Byte6: CRC Byte7: Serial number [63:56] Byte8: Serial number [55:48] Byte9: CRC Byte10: Serial number [47:40] Byte11: Serial number [39:32] Byte12: CRC Byte13: Serial number [31:24] Byte14: Serial number [23:16] Byte15: CRC Byte16: Serial number [15:8] Byte17: Serial number [7:0] Byte18: CRC	Note that the command need to be preceded with an I ² C write header (I ² C address + W). The command returns: <ul style="list-style-type: none"> - 32-bit unique product and revision number. The number is listed in Table 13 below. <i>Note that the last 8 bits are the revision number and are subject to change as long as the datasheet is preliminary.</i> - 64-bit unique serial number in the format of an unsigned long integer. The serial number can be converted from binary into decimal, whereby in decimal it has the following format: <i>yywwwxxxxxx</i> , where: <i>yy</i> : last 2 digits of calibration year, <i>ww</i> : calibration week, <i>xxxxxx</i> : unique 6-digit sequential number within the calibration week.

Table 12: Read product identifier command

Product	Product number	Comment
SFM3003-300-CL	0x04020110	Last two digits: 8x indicating a prototype
SFM3003-300-CE	0x04020710	1x indicating finalized products, therefore last two bytes expected to change during development

Table 13: Product numbers for SFM3003 versions

4.4 Checksum Calculation

The 8-bit CRC checksum transmitted after each data word is generated by a CRC algorithm. Its properties are listed in Table 14. The CRC covers the contents of the two previously transmitted data bytes. To calculate the checksum, only these two previously transmitted data bytes are used.

Property	Value
Name	CRC-8

Protected data	read data
Width	8 bit
Polynomial	0x31 (x8 + x5 + x4 + 1)
Initialization	0xFF
Reflect input	False
Reflect output	False
Final XOR	0x00
Example	CRC (0xBEEF) = 0x92

Table 14: Checksum definition

4.5 Number Format and Conversion to Physical Values

The number format of the flow and temperature signals and the conversion to a physical value with a scale factor and an offset where applicable is explained below:

4.5.1 Scale Factors and Offsets

Signal	SFM3003-300-CL		SFM3003-300-CE		Comment
	Scale Factor	Offset	Scale Factor	Offset	
Gas 0: O2	170 slm ⁻¹	-24576	120 slm ⁻¹	-12288	Can be read out using an I ² C-command (c.f. Sec. 0)
Gas 1: Air	170 slm ⁻¹	-24576	120 slm ⁻¹	-12288	
Gas mixture 0: Gas1- Gas0	170 slm ⁻¹	-24576	120 slm ⁻¹	-12288	
Temperature	200 °C ⁻¹	0	200 °C ⁻¹	0	

Table 15: Scale factors and offsets

4.5.2 Flow

The digital calibrated gas flow signal read from the sensor is a 16-bit signed integer number represented by a two's complement (ranging from -32'768 to 32'767). The integer value can be converted to the physical value by subtracting the offset and dividing it by the scale factor (gas flow in $slm = \frac{sensor\ output - offset}{scale\ factor}$). The scale factor and offset are specific to every calibrated gas / gas mixture / lookup table.

The flow unit slm signifies standard liters per minute with reference temperature equal to 20°C and reference pressure equal to 1013mbar.

4.5.3 Temperature

The digital calibrated temperature signal read from the sensor is a 16-bit signed integer number represented by a two's complement (ranging from -32'768 to 32'767). The integer value can be converted to the physical value by subtracting the offset and dividing it by the scale factor (temperature in °C = $\frac{Sensor\ Output - offset}{Scale\ factor}$).

4.5.4 Flow Unit

1. The flow unit is specific to every calibrated gas / gas mixture / lookup table and is specified in Section 4.5.1. It can further be read out using an I²C-command (Section 4.3.6). The flow unit is given by a 16-bit unsigned word, where the information about the unit is encoded in the first 13 bits as follows: Bits <3:0>: unit prefix (multiplier)
2. Bits <7:4>: time base (e.g. per minute)
3. Bits <12:8>: unit (e.g. standard liter)

The allowed values for the 3 unit constituents are given in the table below:

Bits <12:8>	Signification: Unit	Bits <7:4>	Signification: Time Base	Bits <3:0>	Signification: Unit Prefix	overall code (16 bits)	Signification: flow unit
0b00001 = 1	standard liter ($T_0=20^{\circ}\text{C}$, $p_0=1013\text{mbar}$)	0b0100 = 4	per minute	0b1000 = 8	$10^0 = 1$	0b 0000 0001 0100 1000 = 0×0148 = 328	standard liter per minute (slm) with reference temperature = 20°C and reference pressure =1013mbar

Table 16: Possible result(s) for the flow unit

5. Package Outline

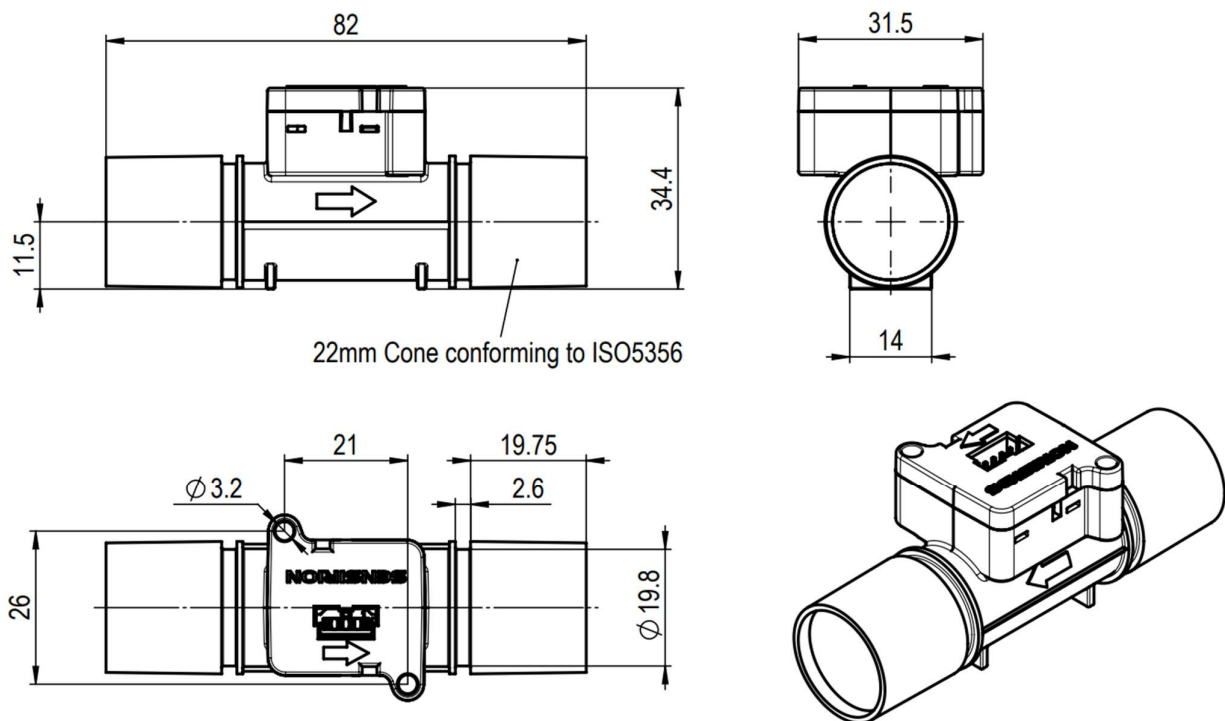

6. Shipping Package

- Packing units: 20 items/tray. Tray dimensions: 38.3 x 28.3 x 4.7 cm.
- Minimal order quantity: 6 trays. Box dimensions for 6 trays: 41 x 31 x 32 cm.

7. Revision History

Date	Author	Version	Changes
27.04.2021	JKEL/LOEH/DAT	V0.8	Corrections in all chapters, update Spec SFM3003-300-CE, removed preliminary status
07.2021	PSIM	v1.0	footnote correction on noise.