



**InvenSense Inc.**

1197 Borregas Ave, Sunnyvale, CA 94089 U.S.A.  
Tel: +1 (408) 988-7339 Fax: +1 (408) 988-8104  
Website: [www.invensense.com](http://www.invensense.com)

Document Number: PS-ITG-3200A-00-01.4  
Revision: 1.4  
Release Date: 03/30/2010

# **ITG-3200 Product Specification Revision 1.4**



## CONTENTS

<b>1</b>	<b>DOCUMENT INFORMATION</b>	<b>4</b>
1.1	REVISION HISTORY	4
1.2	PURPOSE AND SCOPE	5
1.3	PRODUCT OVERVIEW	5
1.4	APPLICATIONS	5
<b>2</b>	<b>FEATURES</b>	<b>6</b>
<b>3</b>	<b>ELECTRICAL CHARACTERISTICS</b>	<b>7</b>
3.1	SENSOR SPECIFICATIONS	7
3.2	ELECTRICAL SPECIFICATIONS	8
3.3	ELECTRICAL SPECIFICATIONS, CONTINUED	9
3.4	ELECTRICAL SPECIFICATIONS, CONTINUED	10
3.5	I <sup>2</sup> C TIMING CHARACTERIZATION	11
3.6	ABSOLUTE MAXIMUM RATINGS	12
<b>4</b>	<b>APPLICATIONS INFORMATION</b>	<b>13</b>
4.1	PIN OUT AND SIGNAL DESCRIPTION	13
4.2	TYPICAL OPERATING CIRCUIT	14
4.3	BILL OF MATERIALS FOR EXTERNAL COMPONENTS	14
4.4	RECOMMENDED POWER-ON PROCEDURE	15
<b>5</b>	<b>FUNCTIONAL OVERVIEW</b>	<b>16</b>
5.1	BLOCK DIAGRAM	16
5.2	OVERVIEW	16
5.3	THREE-AXIS MEMS GYROSCOPE WITH 16-BIT ADCS AND SIGNAL CONDITIONING	16
5.4	I <sup>2</sup> C SERIAL COMMUNICATIONS INTERFACE	17
5.5	CLOCKING	17
5.6	SENSOR DATA REGISTERS	17
5.7	INTERRUPTS	17
5.8	DIGITAL-OUTPUT TEMPERATURE SENSOR	17
5.9	BIAS AND LDO	17
5.10	CHARGE PUMP	17
<b>6</b>	<b>DIGITAL INTERFACE</b>	<b>18</b>
6.1	I <sup>2</sup> C SERIAL INTERFACE	18
<b>7</b>	<b>REGISTER MAP</b>	<b>22</b>
<b>8</b>	<b>REGISTER DESCRIPTION</b>	<b>23</b>
8.1	REGISTER 0 – WHO AM I	23
8.2	REGISTER 21 – SAMPLE RATE DIVIDER	23
8.3	REGISTER 22 – DLPF, FULL SCALE	24
8.4	REGISTER 23 – INTERRUPT CONFIGURATION	26
8.5	REGISTER 26 – INTERRUPT STATUS	26
8.6	REGISTERS 27 TO 34 – SENSOR REGISTERS	27
8.7	REGISTER 62 – POWER MANAGEMENT	27
<b>9</b>	<b>ASSEMBLY</b>	<b>29</b>
9.1	ORIENTATION	29
9.2	PACKAGE DIMENSIONS	30
9.3	PACKAGE MARKING SPECIFICATION	31
9.4	TAPE & REEL SPECIFICATION	31



**ITG-3200 Product Specification**

Document Number: PS-ITG-3200A-00-01.4  
Revision: 1.4  
Release Date: 03/30/2010

9.5 LABEL .....33  
9.6 PACKAGING.....33  
9.7 SOLDERING EXPOSED DIE PAD.....34  
9.8 COMPONENT PLACEMENT .....34  
9.9 PCB MOUNTING AND CROSS-AXIS SENSITIVITY.....34  
9.10 MEMS HANDLING INSTRUCTIONS .....35  
9.11 GYROSCOPE SURFACE MOUNT GUIDELINES.....35  
9.12 REFLOW SPECIFICATION.....35  
9.13 STORAGE SPECIFICATIONS .....37  
**10 RELIABILITY .....38**  
10.1 QUALIFICATION TEST POLICY .....38  
10.2 QUALIFICATION TEST PLAN .....38



## 1 Document Information

### 1.1 Revision History

Revision Date	Revision	Description
10/23/09	1.0	Initial Release
10/28/09	1.1	Edits for readability
02/12/2010	1.2	<ul style="list-style-type: none"><li>• Changed full-scale range and sensitivity scale factor (Sections 2, 3.1, 5.3, and 8.3)</li><li>• Changed sensitivity scale factor variation over temperature (Section 3.1)</li><li>• Changed total RMS noise spec (Section 3.1)</li><li>• Added range for temperature sensor (Section 3.1)</li><li>• Updated VDD Power-Supply Ramp Rate specification (Sections 3.2 and 4.4)</li><li>• Added VLOGIC Voltage Range condition (Section 3.2)</li><li>• Added VLOGIC Reference Voltage Ramp Rate specification (Sections 3.2 and 4.4)</li><li>• Updated Start-Up Time for Register Read/Write specification (Section 3.2)</li><li>• Updated Input logic levels for AD0 and CLKIN (Section 3.2)</li><li>• Updated Level <math>I_{OL}</math> specifications for the I<sup>2</sup>C interface (Section 3.3)</li><li>• Updated Frequency Variation Over Temperature specification for internal clock source (Section 3.4)</li><li>• Updated VLOGIC conditions for I<sup>2</sup>C Characterization (Section 3.5)</li><li>• Updated ESD specification (Section 3.6)</li><li>• Added termination requirements for CLKIN if unused (Section 4.1)</li><li>• Added recommended power-on procedure diagram (Section 4.4)</li><li>• Changed DLPF_CFG setting 7 to reserved (Section 8.3)</li><li>• Changed Reflow Specification description (Section 9.12)</li><li>• Removed errata specifications</li></ul>
03/05/2010	1.3	<ul style="list-style-type: none"><li>• Updated temperature sensor linearity spec (Section 3.1)</li><li>• Updated VDD Power-Supply Ramp Rate timing figure (Sections 3.2 and 4.4)</li><li>• Updated VLOGIC Reference Voltage timing figure (Section 4.4)</li><li>• Added default values to registers (all of Section 8)</li><li>• Updated FS_SEL description (Section 8.3)</li><li>• Updated package outline drawing and dimensions (Section 9.2)</li><li>• Updated Reliability (Section 10.1 and 10.2)</li><li>• Removed Environmental Compliance (Section 11)</li></ul>
03/30/2010	1.4	<ul style="list-style-type: none"><li>• Removed confidentiality mark</li></ul>



## 1.2 Purpose and Scope

This document is a preliminary product specification, providing a description, specifications, and design related information for the ITG-3200™. Electrical characteristics are based upon simulation results and limited characterization data of advanced samples only. Specifications are subject to change without notice. Final specifications will be updated based upon characterization of final silicon.

## 1.3 Product Overview

The ITG-3200 is the world's first single-chip, digital-output, 3-axis MEMS gyro IC optimized for gaming, 3D mice, and 3D remote control applications. The part features enhanced bias and sensitivity temperature stability, reducing the need for user calibration. Low frequency noise is lower than previous generation devices, simplifying application development and making for more-responsive remote controls.

The ITG-3200 features three 16-bit analog-to-digital converters (ADCs) for digitizing the gyro outputs, a user-selectable internal low-pass filter bandwidth, and a Fast-Mode I<sup>2</sup>C (400kHz) interface. Additional features include an embedded temperature sensor and a 2% accurate internal oscillator. This breakthrough in gyroscope technology provides a dramatic 67% package size reduction, delivers a 50% power reduction, and has inherent cost advantages compared to competing multi-chip gyro solutions.

By leveraging its patented and volume-proven Nasiri-Fabrication platform, which integrates MEMS wafers with companion CMOS electronics through wafer-level bonding, InvenSense has driven the ITG-3200 package size down to a revolutionary footprint of 4x4x0.9mm (QFN), while providing the highest performance, lowest noise, and the lowest cost semiconductor packaging required for handheld consumer electronic devices. The part features a robust 10,000g shock tolerance, as required by portable consumer equipment.

For power supply flexibility, the ITG-3200 has a separate VLOGIC reference pin, in addition to its analog supply pin, VDD, which sets the logic levels of its I<sup>2</sup>C interface. The VLOGIC voltage may be anywhere from 1.71V min to VDD max.

## 1.4 Applications

- Motion-enabled game controllers
- Motion-based portable gaming
- Motion-based 3D mice and 3D remote controls
- “No Touch” UI
- Health and sports monitoring



## 2 Features

The ITG-3200 triple-axis MEMS gyroscope includes a wide range of features:

- Digital-output X-, Y-, and Z-Axis angular rate sensors (gyros) on one integrated circuit with a sensitivity of 14.375 LSBs per °/sec and a full-scale range of  $\pm 2000^\circ/\text{sec}$
- Three integrated 16-bit ADCs provide simultaneous sampling of gyros while requiring no external multiplexer
- Enhanced bias and sensitivity temperature stability reduces the need for user calibration
- Low frequency noise lower than previous generation devices, simplifying application development and making for more-responsive motion processing
- Digitally-programmable low-pass filter
- Low 6.5mA operating current consumption for long battery life
- Wide VDD supply voltage range of 2.1V to 3.6V
- Flexible VLOGIC reference voltage allows for I<sup>2</sup>C interface voltages from 1.71V to VDD
- Standby current: 5 $\mu$ A
- Smallest and thinnest package for portable devices (4x4x0.9mm QFN)
- No high pass filter needed
- Turn on time: 50ms
- Digital-output temperature sensor
- Factory calibrated scale factor
- 10,000 g shock tolerant
- Fast Mode I<sup>2</sup>C (400kHz) serial interface
- On-chip timing generator clock frequency is accurate to  $\pm 2\%$  over full temperature range
- Optional external clock inputs of 32.768kHz or 19.2MHz to synchronize with system clock
- MEMS structure hermetically sealed and bonded at wafer level
- RoHS and Green compliant



### 3 Electrical Characteristics

#### 3.1 Sensor Specifications

Typical Operating Circuit of Section 4.2, VDD = 2.5V, VLOGIC = 1.71V to VDD, T<sub>A</sub>=25°C.

Parameter	Conditions	Min	Typical	Max	Unit	Note
<b>GYRO SENSITIVITY</b>						
Full-Scale Range	FS_SEL=3		±2000		°/s	4
Gyro ADC Word Length			16		Bits	3
Sensitivity Scale Factor	FS_SEL=3		14.375		LSB/(°/s)	3
Sensitivity Scale Factor Tolerance	25°C	-6		+6	%	1
Sensitivity Scale Factor Variation Over Temperature			±10		%	2
Nonlinearity	Best fit straight line; 25°C		0.2		%	6
Cross-Axis Sensitivity			2		%	6
<b>GYRO ZERO-RATE OUTPUT (ZRO)</b>						
Initial ZRO Tolerance			±40		°/s	1
ZRO Variation Over Temperature	-40°C to +85°C		±40		°/s	2
Power-Supply Sensitivity (1-10Hz)	Sine wave, 100mVpp; VDD=2.2V		0.2		°/s	5
Power-Supply Sensitivity (10 - 250Hz)	Sine wave, 100mVpp; VDD=2.2V		0.2		°/s	5
Power-Supply Sensitivity (250Hz - 100kHz)	Sine wave, 100mVpp; VDD=2.2V		4		°/s	5
Linear Acceleration Sensitivity	Static		0.1		°/s/g	6
<b>GYRO NOISE PERFORMANCE</b>						
Total RMS noise	FS_SEL=3 100Hz LPF (DLPFCFG=2)		0.38		°/s-rms	1
Rate Noise Spectral Density	At 10Hz		0.03		°/s/√Hz	2
<b>GYRO MECHANICAL FREQUENCIES</b>						
X-Axis		30	33	36	kHz	1
Y-Axis		27	30	33	kHz	1
Z-Axis		24	27	30	kHz	1
Frequency Separation	Between any two axes	1.7			kHz	1
<b>GYRO START-UP TIME</b>						
ZRO Settling	DLPFCFG=0 to ±1% of Final		50		ms	6
<b>TEMPERATURE SENSOR</b>						
Range			-30 to +85		°C	2
Sensitivity			280		LSB/°C	2
Temperature Offset	35°C		-13,200		LSB	1
Initial Accuracy	35°C		TBD		°C	
Linearity	Best fit straight line (-30°C to +85°C)		±1		°C	2, 5
<b>TEMPERATURE RANGE</b>						
Specified Temperature Range		-40		85	°C	

**Notes:**

1. Tested in production
2. Based on characterization of 30 pieces over temperature on evaluation board or in socket
3. Based on design, through modeling and simulation across PVT
4. Typical. Randomly selected part measured at room temperature on evaluation board or in socket
5. Based on characterization of 5 pieces over temperature
6. Tested on 5 parts at room temperature



## ITG-3200 Product Specification

Document Number: PS-ITG-3200A-00-01.4  
 Revision: 1.4  
 Release Date: 03/30/2010

### 3.2 Electrical Specifications

Typical Operating Circuit of Section 4.2, VDD = 2.5V, VLOGIC = 1.71V to VDD, T<sub>A</sub>=25°C.

Parameters	Conditions	Min	Typical	Max	Units	Notes
<b>VDD POWER SUPPLY</b>						
Operating Voltage Range		2.1		3.6	V	2
Power-Supply Ramp Rate	Monotonic ramp. Ramp rate is 10% to 90% of the final value (see Figure in Section 4.4)	0		5	ms	2
Normal Operating Current			6.5		mA	1
Sleep Mode Current			5		μA	5
<b>VLOGIC REFERENCE VOLTAGE</b>						
Voltage Range	VLOGIC must be ≤VDD at all times	1.71		VDD	V	
VLOGIC Ramp Rate	Monotonic ramp. Ramp rate is 10% to 90% of the final value (see Figure in Section 4.4)			1	ms	6
Normal Operating Current			100		μA	
<b>START-UP TIME FOR REGISTER READ/WRITE</b>			20		ms	5
<b>I<sup>2</sup>C ADDRESS</b>	AD0 = 0 AD0 = 1		1101000 1101001			6 6
<b>DIGITAL INPUTS (AD0, CLKIN)</b>						
V <sub>IH</sub> , High Level Input Voltage		0.9*VLOGIC			V	5
V <sub>IL</sub> , Low Level Input Voltage				0.1*VLOGIC	V	5
C <sub>I</sub> , Input Capacitance				5	pF	7
<b>DIGITAL OUTPUT (INT)</b>						
V <sub>OH</sub> , High Level Output Voltage	OPEN=0, Rload=1MΩ	0.9*VLOGIC			V	2
V <sub>OL</sub> , Low Level Output Voltage	OPEN=0, Rload=1MΩ			0.1*VLOGIC	V	2
V <sub>OL,INT1</sub> , INT Low-Level Output Voltage	OPEN=1, 0.3mA sink current			0.1	V	2
Output Leakage Current	OPEN=1		100		nA	4
t <sub>INT</sub> , INT Pulse Width	LATCH_INT_EN=0		50		μs	4

#### Notes:

1. Tested in production
2. Based on characterization of 30 pieces over temperature on evaluation board or in socket
4. Typical. Randomly selected part measured at room temperature on evaluation board or in socket
5. Based on characterization of 5 pieces over temperature
6. Guaranteed by design





### 3.3 Electrical Specifications, continued

Typical Operating Circuit of Section 4.2, VDD = 2.5V, VLOGIC = 1.71V to VDD, T<sub>A</sub>=25°C.

Parameters	Conditions	Typical	Units	Notes
<b>I<sup>2</sup>C I/O (SCL, SDA)</b>				
V <sub>IL</sub> , LOW-Level Input Voltage		-0.5 to 0.3*VLOGIC	V	2
V <sub>IH</sub> , HIGH-Level Input Voltage		0.7*VLOGIC to VLOGIC + 0.5V	V	2
V <sub>hys</sub> , Hysteresis		0.1*VLOGIC	V	2
V <sub>OL1</sub> , LOW-Level Output Voltage	3mA sink current	0 to 0.4	V	2
I <sub>OL</sub> , LOW-Level Output Current	V <sub>OL</sub> = 0.4V	3	mA	2
	V <sub>OL</sub> = 0.6V	6	mA	2
Output Leakage Current		100	nA	4
t <sub>of</sub> , Output Fall Time from V <sub>IHmax</sub> to V <sub>ILmax</sub>	Cb bus cap. in pF	20+0.1Cb to 250	ns	2
C <sub>I</sub> , Capacitance for Each I/O pin		10	pF	5

**Notes:**

2. Based on characterization of 5 pieces over temperature.
4. Typical. Randomly selected part measured at room temperature on evaluation board or in socket
5. Guaranteed by design



## ITG-3200 Product Specification

Document Number: PS-ITG-3200A-00-01.4  
 Revision: 1.4  
 Release Date: 03/30/2010

### 3.4 Electrical Specifications, continued

Typical Operating Circuit of Section 4.2, VDD = 2.5V, VLOGIC = 1.71V to VDD, T<sub>A</sub>=25°C.

Parameters	Conditions	Min	Typical	Max	Units	Notes
<b>INTERNAL CLOCK SOURCE</b>	<b>CLKSEL=0, 1, 2, or 3</b>					
Sample Rate, Fast	DLPFCFG=0 SAMPLERATEDIV = 0		8		kHz	4
Sample Rate, Slow	DLPFCFG=1,2,3,4,5, or 6 SAMPLERATEDIV = 0		1		kHz	4
Clock Frequency Initial Tolerance	CLKSEL=0, 25°C	-2		+2	%	1
	CLKSEL=1,2,3; 25°C	-1		+1	%	1
Frequency Variation over Temperature	CLKSEL=0		-15 to +10		%	2
	CLKSEL=1,2,3		+/-1		%	2
PLL Settling Time	CLKSEL=1,2,3		1		ms	3
<b>EXTERNAL 32.768kHz CLOCK</b>	<b>CLKSEL=4</b>					
External Clock Frequency			32.768		kHz	3
External Clock Jitter	Cycle-to-cycle rms		1 to 2		µs	3
Sample Rate, Fast	DLPFCFG=0 SAMPLERATEDIV = 0		8.192		kHz	3
Sample Rate, Slow	DLPFCFG=1,2,3,4,5, or 6 SAMPLERATEDIV = 0		1.024		kHz	3
PLL Settling Time			1		ms	3
<b>EXTERNAL 19.2MHz CLOCK</b>	<b>CLKSEL=5</b>					
External Clock Frequency			19.2		MHz	3
Sample Rate, Fast	DLPFCFG=0 SAMPLERATEDIV = 0		8		kHz	3
Sample Rate, Slow	DLPFCFG=1,2,3,4,5, or 6 SAMPLERATEDIV = 0		1		kHz	3
PLL Settling Time			1		ms	3
<b>Charge Pump Clock Frequency</b>						
Frequency	1 <sup>st</sup> Stage, 25°C		8.5		MHz	5
	2 <sup>nd</sup> Stage, 25°C		68		MHz	5
	Over temperature		+/-15		%	5

#### Notes:

1. Tested in production
2. Based on characterization of 30 pieces over temperature on evaluation board or in socket
3. Based on design, through modeling and simulation across PVT
4. Typical. Randomly selected part measured at room temperature on evaluation board or in socket
5. Based on characterization of 5 pieces over temperature.

### 3.5 I<sup>2</sup>C Timing Characterization

Typical Operating Circuit of Section 4.2, VDD = 2.5V, VLOGIC = 1.8V±5%, 2.5V±5%, 3.0V±5%, or 3.3V±5%, TA=25°C.

Parameters	Conditions	Min	Typical	Max	Units	Notes
<b>I<sup>2</sup>C TIMING</b>						
<b>I<sup>2</sup>C FAST-MODE</b>						
f <sub>SCL</sub> , SCL Clock Frequency		0		400	kHz	1
t <sub>HD,STA</sub> , (Repeated) START Condition Hold Time		0.6			us	1
t <sub>LOW</sub> , SCL Low Period		1.3			us	1
t <sub>HIGH</sub> , SCL High Period		0.6			us	1
t <sub>SU,STA</sub> , Repeated START Condition Setup Time		0.6			us	1
t <sub>HD,DAT</sub> , SDA Data Hold Time		0			us	1
t <sub>SU,DAT</sub> , SDA Data Setup Time		100			ns	1
t <sub>r</sub> , SDA and SCL Rise Time	Cb bus cap. from 10 to 400pF	20+0.1Cb		300	ns	1
t <sub>f</sub> , SDA and SCL Fall Time	Cb bus cap. from 10 to 400pF	20+0.1Cb		300	ns	1
t <sub>SU,STO</sub> , STOP Condition Setup Time		0.6			us	1
t <sub>BUF</sub> , Bus Free Time Between STOP and START Condition		1.3			us	1
C <sub>b</sub> , Capacitive Load for each Bus Line				400	pF	2
t <sub>VD,DAT</sub> , Data Valid Time				0.9	us	1
t <sub>VD,ACK</sub> , Data Valid Acknowledge Time				0.9	us	1

**Notes:**

1. Based on characterization of 5 pieces over temperature on evaluation board or in socket
2. Guaranteed by design

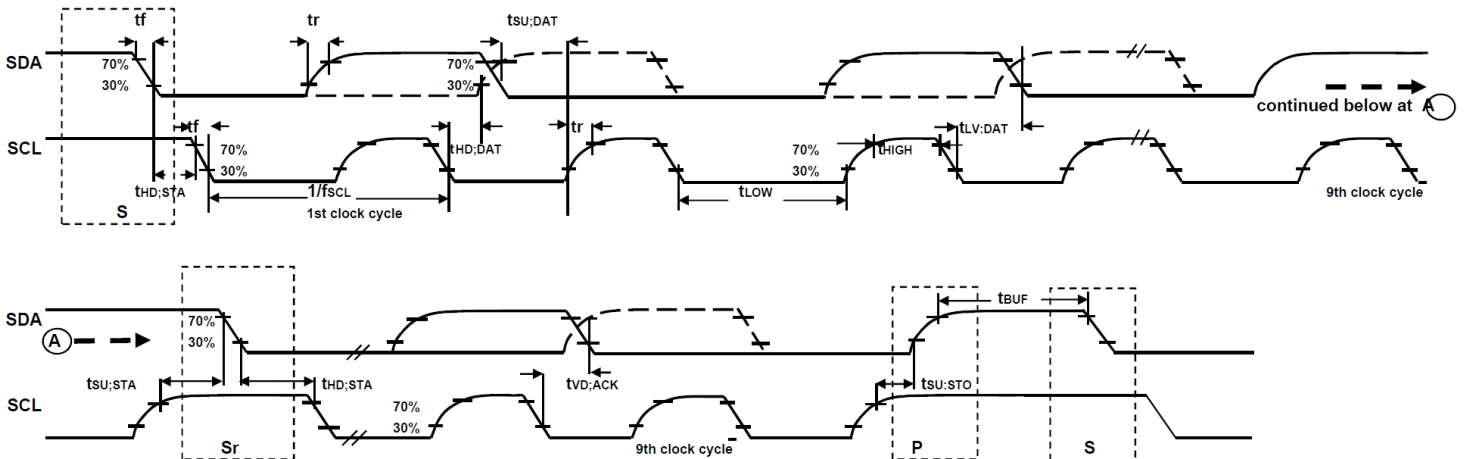

**I<sup>2</sup>C Bus Timing Diagram**



### 3.6 Absolute Maximum Ratings

Stresses above those listed as “Absolute Maximum Ratings” may cause permanent damage to the device. These are stress ratings only and functional operation of the device at these conditions is not implied. Exposure to the absolute maximum ratings conditions for extended periods may affect device reliability.

#### Absolute Maximum Ratings

Parameter	Rating
Supply Voltage, VDD	-0.5V to +6V
VLOGIC Input Voltage Level	-0.5V to VDD + 0.5V
REGOUT	-0.5V to 2V
Input Voltage Level (CLKIN, AD0)	-0.5V to VDD + 0.5V
SCL, SDA, INT	-0.5V to VLOGIC + 0.5V
CPOUT (2.1V ≤ VDD ≤ 3.6V )	-0.5V to 30V
Acceleration (Any Axis, unpowered)	10,000g for 0.3ms
Operating Temperature Range	-40°C to +105°C
Storage Temperature Range	-40°C to +125°C
Electrostatic Discharge (ESD) Protection	1.5kV (HBM); 200V (MM)

## 4 Applications Information

### 4.1 Pin Out and Signal Description

Number	Pin	Pin Description
1	CLKIN	Optional external reference clock input. Connect to GND if unused.
8	VLOGIC	Digital IO supply voltage. VLOGIC must be $\leq$ VDD at all times.
9	AD0	I <sup>2</sup> C Slave Address LSB
10	REGOUT	Regulator filter capacitor connection
12	INT	Interrupt digital output (totem pole or open-drain)
13	VDD	Power supply voltage
18	GND	Power supply ground
11	RESV-G	Reserved - Connect to ground.
6, 7, 19, 21, 22	RESV	Reserved. Do not connect.
20	CPOUT	Charge pump capacitor connection
23	SCL	I <sup>2</sup> C serial clock
24	SDA	I <sup>2</sup> C serial data
2, 3, 4, 5, 14, 15, 16, 17	NC	Not internally connected. May be used for PCB trace routing.

#### Top View

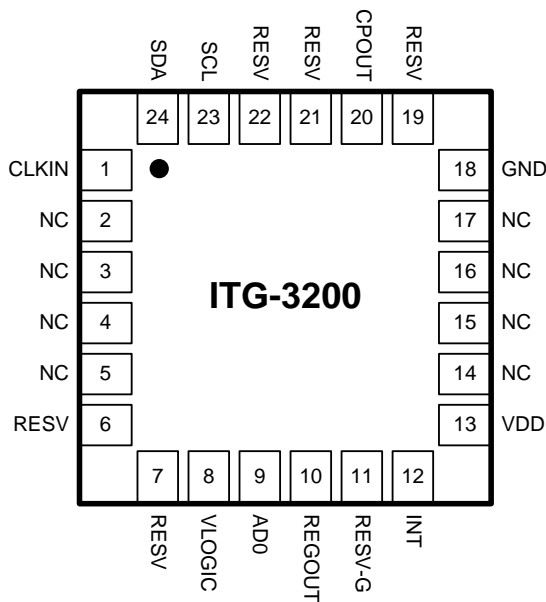

**QFN Package**  
 24-pin, 4mm x 4mm x 0.9mm

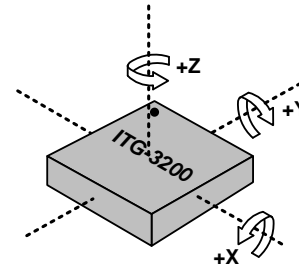

**Orientation of Axes of Sensitivity**  
**and Polarity of Rotation**

4.2 Typical Operating Circuit

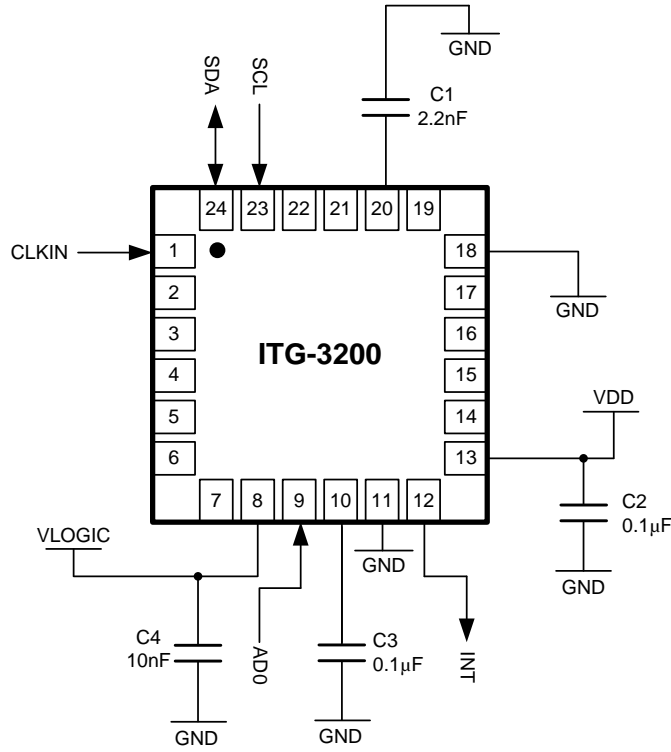

Typical Operating Circuit

4.3 Bill of Materials for External Components

Component	Label	Specification	Quantity
Charge Pump Capacitor	C1	Ceramic, X7R, 2.2nF ±10%, 50V	1
VDD Bypass Capacitor	C2	Ceramic, X7R, 0.1µF ±10%, 4V	1
Regulator Filter Capacitor	C3	Ceramic, X7R, 0.1µF ±10%, 2V	1
VLOGIC Bypass Capacitor	C4	Ceramic, X7R, 10nF ±10%, 4V	1

4.4 Recommended Power-On Procedure

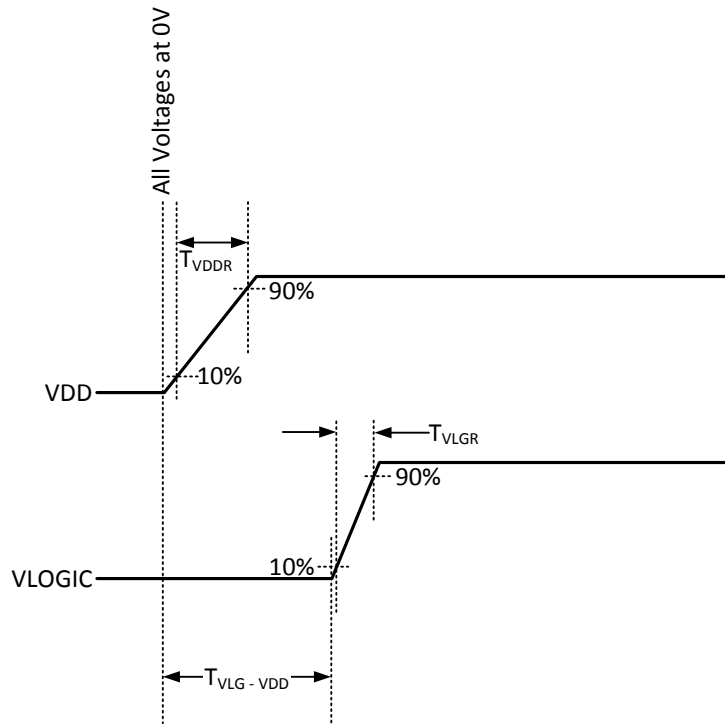

**Power-Up Sequencing**

1.  $T_{VDDR}$  is VDD rise time: Time for VDD to rise from 10% to 90% of its final value
2.  $T_{VDDR}$  is  $\leq 5\text{msec}$
3.  $T_{VLGR}$  is VLOGIC rise time: Time for VLOGIC to rise from 10% to 90% of its final value
4.  $T_{VLGR}$  is  $\leq 1\text{msec}$
5.  $T_{VLG-VDD}$  is the delay from the start of VDD ramp to the start of VLOGIC rise
6.  $T_{VLG-VDD}$  is 0 to 20msec but VLOGIC amplitude must always be  $\leq VDD$  amplitude
7. VDD and VLOGIC must be monotonic ramps

## 5 Functional Overview

### 5.1 Block Diagram

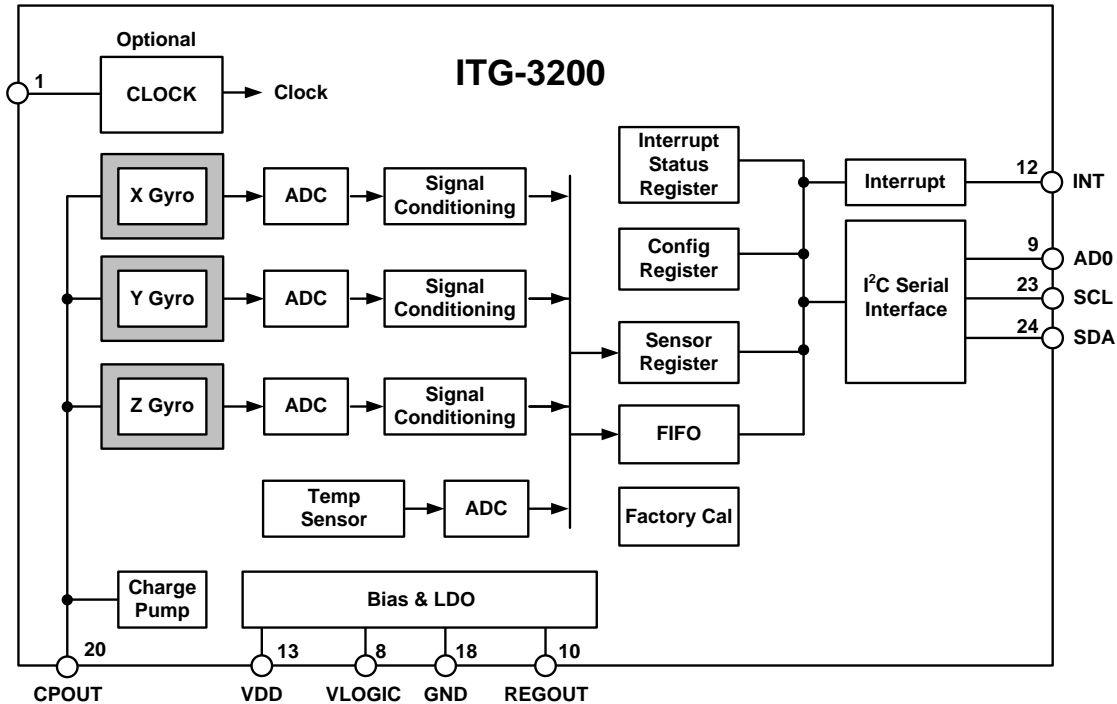

### 5.2 Overview

The ITG-3200 consists of the following key blocks and functions:

- Three-axis MEMS rate gyroscope sensors with individual 16-bit ADCs and signal conditioning
- I<sup>2</sup>C serial communications interface
- Clocking
- Sensor Data Registers
- Interrupts
- Digital-Output Temperature Sensor
- Bias and LDO
- Charge Pump

### 5.3 Three-Axis MEMS Gyroscope with 16-bit ADCs and Signal Conditioning

The ITG-3200 consists of three independent vibratory MEMS gyroscopes, which detect rotational rate about the X (roll), Y (pitch), and Z (yaw) axes. When the gyros are rotated about any of the sense axes, the Coriolis Effect causes a deflection that is detected by a capacitive pickoff. The resulting signal is amplified, demodulated, and filtered to produce a voltage that is proportional to the angular rate. This voltage is digitized using individual on-chip 16-bit Analog-to-Digital Converters (ADCs) to sample each axis.

The full-scale range of the gyro sensors is preset to  $\pm 2000$  degrees per second ( $^{\circ}/s$ ). The ADC output rate is programmable up to a maximum of 8,000 samples per second down to 3.9 samples per second, and user-selectable low-pass filters enable a wide range of cut-off frequencies.



#### 5.4 I<sup>2</sup>C Serial Communications Interface

The ITG-3200 communicates to a system processor using the I<sup>2</sup>C serial interface, and the device always acts as a slave when communicating to the system processor. **The logic level for communications to the master is set by the voltage on the VLOGIC pin.** The LSB of the of the I<sup>2</sup>C slave address is set by pin 9 (AD0).

#### 5.5 Clocking

The ITG-3200 has a flexible clocking scheme, allowing for a variety of internal or external clock sources for the internal synchronous circuitry. This synchronous circuitry includes the signal conditioning, ADCs, and various control circuits and registers. An on-chip PLL provides flexibility in the allowable inputs for generating this clock.

Allowable internal sources for generating the internal clock are:

- An internal relaxation oscillator (less accurate)
- Any of the X, Y, or Z gyros' MEMS oscillators (with an accuracy of  $\pm 2\%$  over temperature)

Allowable external clocking sources are:

- 32.768kHz square wave
- 19.2MHz square wave

Which source to select for generating the internal synchronous clock depends on the availability of external sources and the requirements for clock accuracy. There are also start-up conditions to consider. When the ITG-3200 first starts up, the device operates off of its internal clock until programmed to operate from another source. This allows the user, for example, to wait for the MEMS oscillators to stabilize before they are selected as the clock source.

#### 5.6 Sensor Data Registers

The sensor data registers contain the latest gyro and temperature data. They are read-only registers, and are accessed via the Serial Interface. Data from these registers may be read at any time, however, the interrupt function may be used to determine when new data is available.

#### 5.7 Interrupts

Interrupt functionality is configured via the Interrupt Configuration register. Items that are configurable include the INT pin configuration, the interrupt latching and clearing method, and triggers for the interrupt. Items that can trigger an interrupt are (1) Clock generator locked to new reference oscillator (used when switching clock sources); and (2) new data is available to be read from the Data registers. The interrupt status can be read from the Interrupt Status register.

#### 5.8 Digital-Output Temperature Sensor

An on-chip temperature sensor and ADC are used to measure the ITG-3200 die temperature. The readings from the ADC can be read from the Sensor Data registers.

#### 5.9 Bias and LDO

The bias and LDO sections take in an unregulated VDD supply from 2.1V to 3.6V and generate the internal supply and the references voltages and currents required by the ITG-3200. The LDO output is bypassed by a capacitor at REGOUT. Additionally, the part has a VLOGIC reference voltage which sets the logic levels for its I<sup>2</sup>C interface.

#### 5.10 Charge Pump

An on-board charge pump generates the high voltage (25V) required to drive the MEMS oscillators. Its output is bypassed by a capacitor at CPOUT.

## 6 Digital Interface

### 6.1 I<sup>2</sup>C Serial Interface

The internal registers and memory of the ITG-3200 can be accessed using I<sup>2</sup>C at up to 400kHz.

#### Serial Interface

Pin Number	Pin Name	Pin Description
8	VLOGIC	Digital IO supply voltage. VLOGIC must be $\leq$ VDD at all times.
9	AD0	I <sup>2</sup> C Slave Address LSB
23	SCL	I <sup>2</sup> C serial clock
24	SDA	I <sup>2</sup> C serial data

#### 6.1.1 I<sup>2</sup>C Interface

I<sup>2</sup>C is a two wire interface comprised of the signals serial data (SDA) and serial clock (SCL). In general, the lines are open-drain and bi-directional. In a generalized I<sup>2</sup>C interface implementation, attached devices can be a master or a slave. The master device puts the slave address on the bus, and the slave device with the matching address acknowledges the master.

The ITG-3200 always operates as a slave device when communicating to the system processor, which thus acts as the master. SDA and SCL lines typically need pull-up resistors to VDD. The maximum bus speed is 400kHz.

The slave address of the ITG-3200 devices is b110100X which is 7 bits long. The LSB bit of the 7 bit address is determined by the logic level on pin 9. This allows two ITG-3200 devices to be connected to the same I<sup>2</sup>C bus. When used in this configuration, the address of the one of the devices should be b1101000 (pin 9 is logic low) and the address of the other should be b1101001 (pin 9 is logic high). The I<sup>2</sup>C address is stored in register 0 (WHO\_AM\_I register).

#### I<sup>2</sup>C Communications Protocol

##### START (S) and STOP (P) Conditions

Communication on the I<sup>2</sup>C bus starts when the master puts the START condition (S) on the bus, which is defined as a HIGH-to-LOW transition of the SDA line while SCL line is HIGH (see figure below). The bus is considered to be busy until the master puts a STOP condition (P) on the bus, which is defined as a LOW to HIGH transition on the SDA line while SCL is HIGH (see figure below).

Additionally, the bus remains busy if a repeated START (Sr) is generated instead of a STOP condition.

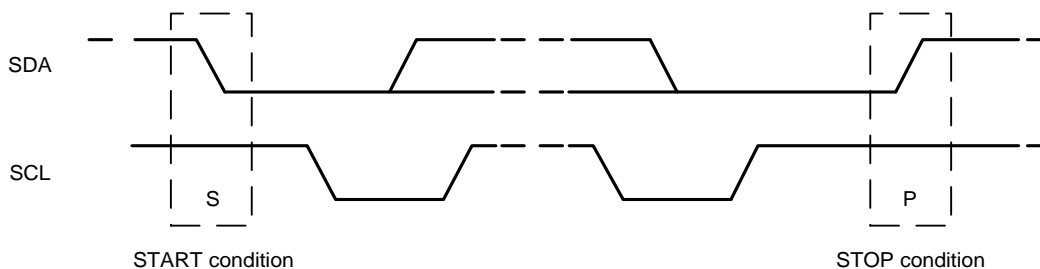

**START and STOP Conditions**

Data Format / Acknowledge

I<sup>2</sup>C data bytes are defined to be 8 bits long. There is no restriction to the number of bytes transmitted per data transfer. Each byte transferred must be followed by an acknowledge (ACK) signal. The clock for the acknowledge signal is generated by the master, while the receiver generates the actual acknowledge signal by pulling down SDA and holding it low during the HIGH portion of the acknowledge clock pulse.

If a slave is busy and cannot transmit or receive another byte of data until some other task has been performed, it can hold SCL LOW, thus forcing the master into a wait state. Normal data transfer resumes when the slave is ready, and releases the clock line (see figure below).

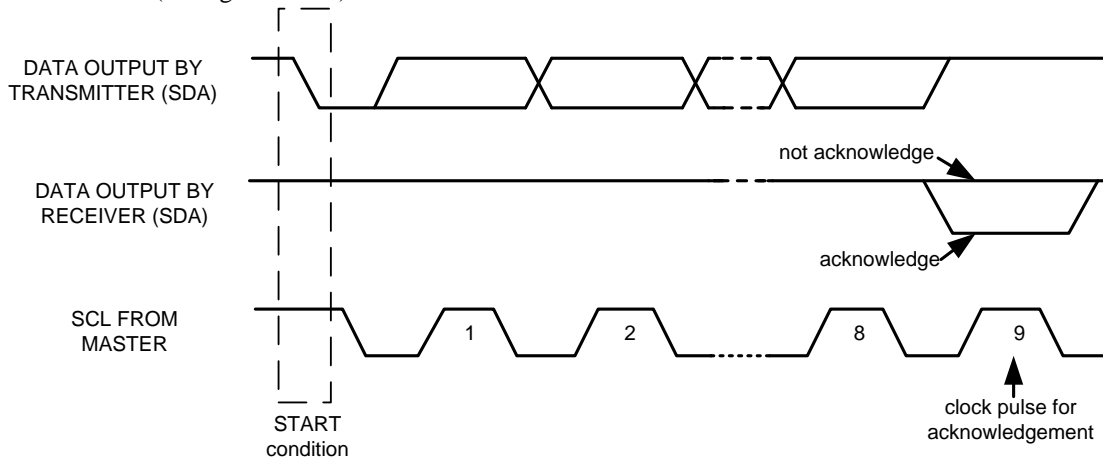

**Acknowledge on the I<sup>2</sup>C Bus**

Communications

After beginning communications with the START condition (S), the master sends a 7-bit slave address followed by an 8<sup>th</sup> bit, the read/write bit. The read/write bit indicates whether the master is receiving data from or is writing to the slave device. Then, the master releases the SDA line and waits for the acknowledge signal (ACK) from the slave device. Each byte transferred must be followed by an acknowledge bit. To acknowledge, the slave device pulls the SDA line LOW and keeps it LOW for the high period of the SCL line. Data transmission is always terminated by the master with a STOP condition (P), thus freeing the communications line. However, the master can generate a repeated START condition (Sr), and address another slave without first generating a STOP condition (P). A LOW to HIGH transition on the SDA line while SCL is HIGH defines the stop condition. All SDA changes should take place when SCL is low, with the exception of start and stop conditions.

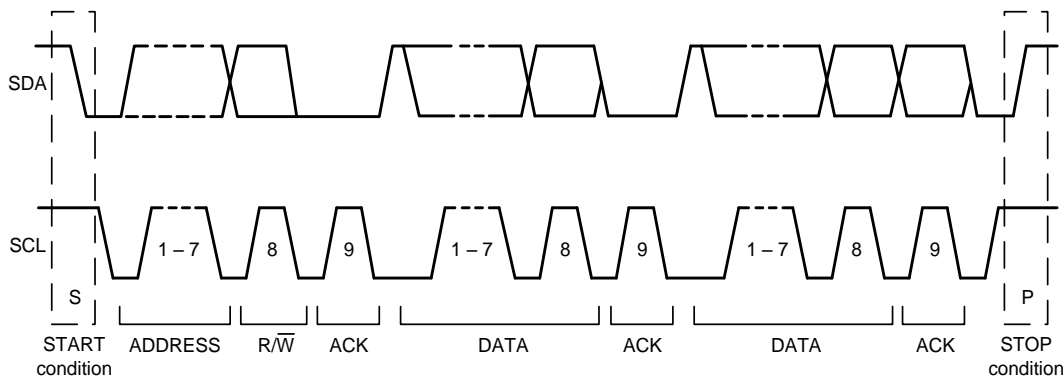

**Complete I<sup>2</sup>C Data Transfer**



To write the internal ITG-3200 device registers, the master transmits the start condition (S), followed by the I<sup>2</sup>C address and the write bit (0). At the 9<sup>th</sup> clock cycle (when the clock is high), the ITG-3200 device acknowledges the transfer. Then the master puts the register address (RA) on the bus. After the ITG-3200 acknowledges the reception of the register address, the master puts the register data onto the bus. This is followed by the ACK signal, and data transfer may be concluded by the stop condition (P). To write multiple bytes after the last ACK signal, the master can continue outputting data rather than transmitting a stop signal. In this case, the ITG-3200 device automatically increments the register address and loads the data to the appropriate register. The following figures show single and two-byte write sequences.

**Single-Byte Write Sequence**

Master	S	AD+W		RA		DATA		P
Slave			ACK		ACK		ACK	

**Burst Write Sequence**

Master	S	AD+W		RA		DATA		DATA		P
Slave			ACK		ACK		ACK		ACK	

To read the internal ITG-3200 device registers, the master first transmits the start condition (S), followed by the I<sup>2</sup>C address and the write bit (0). At the 9<sup>th</sup> clock cycle (when clock is high), the ITG acknowledges the transfer. The master then writes the register address that is going to be read. Upon receiving the ACK signal from the ITG-3200, the master transmits a start signal followed by the slave address and read bit. As a result, the ITG-3200 sends an ACK signal and the data. The communication ends with a not acknowledge (NACK) signal and a stop bit from master. The NACK condition is defined such that the SDA line remains high at the 9<sup>th</sup> clock cycle. To read multiple bytes of data, the master can output an acknowledge signal (ACK) instead of a not acknowledge (NACK) signal. In this case, the ITG-3200 automatically increments the register address and outputs data from the appropriate register. The following figures show single and two-byte read sequences.

**Single-Byte Read Sequence**

Master	S	AD+W		RA		S	AD+R			NACK	P
Slave			ACK		ACK			ACK	DATA		

**Burst Read Sequence**

Master	S	AD+W		RA		S	AD+R			ACK		NACK	P
Slave			ACK		ACK			ACK	DATA		DATA		



**I<sup>2</sup>C Terms**

Signal	Description
S	Start Condition: SDA goes from high to low while SCL is high
AD	Slave I <sup>2</sup> C address
W	Write bit (0)
R	Read bit (1)
ACK	Acknowledge: SDA line is low while the SCL line is high at the 9 <sup>th</sup> clock cycle
NACK	Not-Acknowledge: SDA line stays high at the 9 <sup>th</sup> clock cycle
RA	ITG-3200 internal register address
DATA	Transmit or received data
P	Stop condition: SDA going from low to high while SCL is high



## ITG-3200 Product Specification

Document Number: PS-ITG-3200A-00-01.4  
 Revision: 1.4  
 Release Date: 03/30/2010

### 7 Register Map

Addr Hex	Addr Decimal	Register Name	R/W	Bit7	Bit6	Bit5	Bit4	Bit3	Bit2	Bit1	Bit0
0	0	WHO_AM_I	R/W	-	ID						-
15	21	SMPLRT_DIV	R/W	SMPLRT_DIV							
16	22	DLPF_FS	R/W	-	-	-	FS_SEL		DLPF_CFG		
17	23	INT_CFG	R/W	ACTL	OPEN	LATCH_INT_EN	INT_ANYRD_2CLEAR	-	ITG_RDY_EN	-	RAW_RDY_EN
1A	26	INT_STATUS	R	-	-	-	-	-	ITG_RDY	-	RAW_DATA_RDY
1B	27	TEMP_OUT_H	R	TEMP_OUT_H							
1C	28	TEMP_OUT_L	R	TEMP_OUT_L							
1D	29	GYRO_XOUT_H	R	GYRO_XOUT_H							
1E	30	GYRO_XOUT_L	R	GYRO_XOUT_L							
1F	31	GYRO_YOUT_H	R	GYRO_YOUT_H							
20	32	GYRO_YOUT_L	R	GYRO_YOUT_L							
21	33	GYRO_ZOUT_H	R	GYRO_ZOUT_H							
22	34	GYRO_ZOUT_L	R	GYRO_ZOUT_L							
3E	62	PWR_MGM	R/W	H_RESET	SLEEP	STBY_XG	STBY_YG	STBY_ZG	CLK_SEL		



## 8 Register Description

This section details each register within the InvenSense ITG-3200 gyroscope. Note that any bit that is not defined should be set to zero in order to be compatible with future InvenSense devices.

The register space allows single-byte reads and writes, as well as burst reads and writes. When performing burst reads or writes, the memory pointer will increment until either (1) reading or writing is terminated by the master, or (2) the memory pointer reaches certain reserved registers between registers 33 and 60.

### 8.1 Register 0 – Who Am I

**Type: Read/Write**

Register (Hex)	Register (Decimal)	Bit7	Bit6	Bit5	Bit4	Bit3	Bit2	Bit1	Bit0
0	0	-	ID						-

**Description:**

This register is used to verify the identity of the device.

**Parameters:**

*ID* Contains the I<sup>2</sup>C address of the device, which can also be changed by writing to this register.

The Power-On-Reset value of Bit6: Bit1 is 110 100.

### 8.2 Register 21 – Sample Rate Divider

**Type: Read/Write**

Register (Hex)	Register (Decimal)	Bit7	Bit6	Bit5	Bit4	Bit3	Bit2	Bit1	Bit0	Default Value
15	21	SMPLRT_DIV								00h

**Description:**

This register determines the sample rate of the ITG-3200 gyros. The gyros outputs are sampled internally at either 1kHz or 8kHz, determined by the *DLPF\_CFG* setting (see register 22). This sampling is then filtered digitally and delivered into the sensor registers after the number of cycles determined by this register. The sample rate is given by the following formula:

$$F_{\text{sample}} = F_{\text{internal}} / (\text{divider} + 1), \text{ where } F_{\text{internal}} \text{ is either } 1\text{kHz or } 8\text{kHz}$$

As an example, if the internal sampling is at 1kHz, then setting this register to 7 would give the following:

$$F_{\text{sample}} = 1\text{kHz} / (7 + 1) = 125\text{Hz, or } 8\text{ms per sample}$$

**Parameters:**

*SMPLRT\_DIV* Sample rate divider: 0 to 255



### 8.3 Register 22 – DLPF, Full Scale

Type: Read/Write

Register (Hex)	Register (Decimal)	Bit7	Bit6	Bit5	Bit4	Bit3	Bit2	Bit1	Bit0	Default Value
16	22	-			FS_SEL		DLPF_CFG			00h

**Description:**

This register configures several parameters related to the sensor acquisition.

The *FS\_SEL* parameter allows setting the full-scale range of the gyro sensors, as described in the table below.

The power-on-reset value of *FS\_SEL* is 00h. **Set to 03h for proper operation.**

**FS\_SEL**

FS_SEL	Gyro Full-Scale Range
0	Reserved
1	Reserved
2	Reserved
3	±2000°/sec

The *DLPF\_CFG* parameter sets the digital low pass filter configuration. It also determines the internal sampling rate used by the device as shown in the table below.

**DLPF\_CFG**

DLPF_CFG	Low Pass Filter Bandwidth	Internal Sample Rate
0	256Hz	8kHz
1	188Hz	1kHz
2	98Hz	1kHz
3	42Hz	1kHz
4	20Hz	1kHz
5	10Hz	1kHz
6	5Hz	1kHz
7	Reserved	Reserved

**Parameters:**

*FS\_SEL* Full scale selection for gyro sensor data

*DLPF\_CFG* Digital low pass filter configuration and internal sampling rate configuration



**DLPF Characteristics:** The gain and phase responses of the digital low pass filter settings (*DLPF\_CFG*) are shown below:

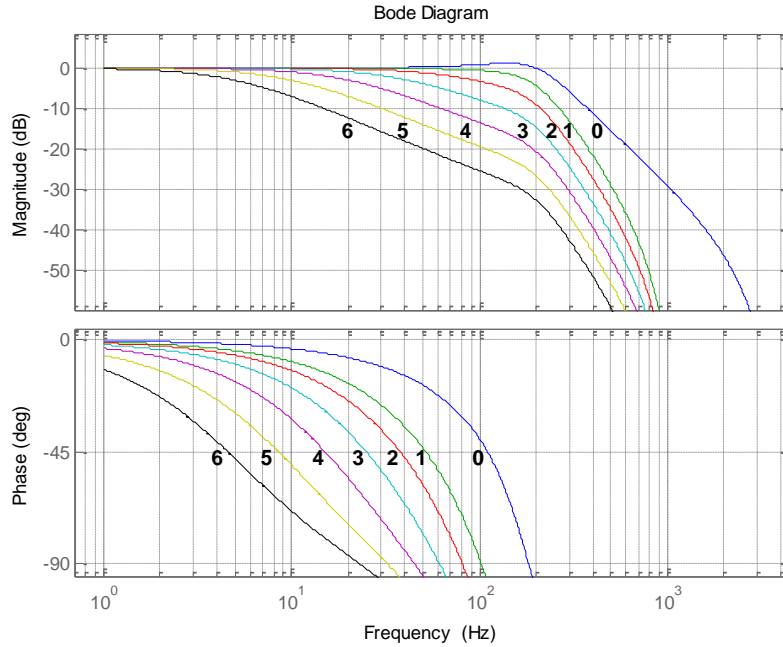

**Gain and Phase vs. Digital Filter Setting**

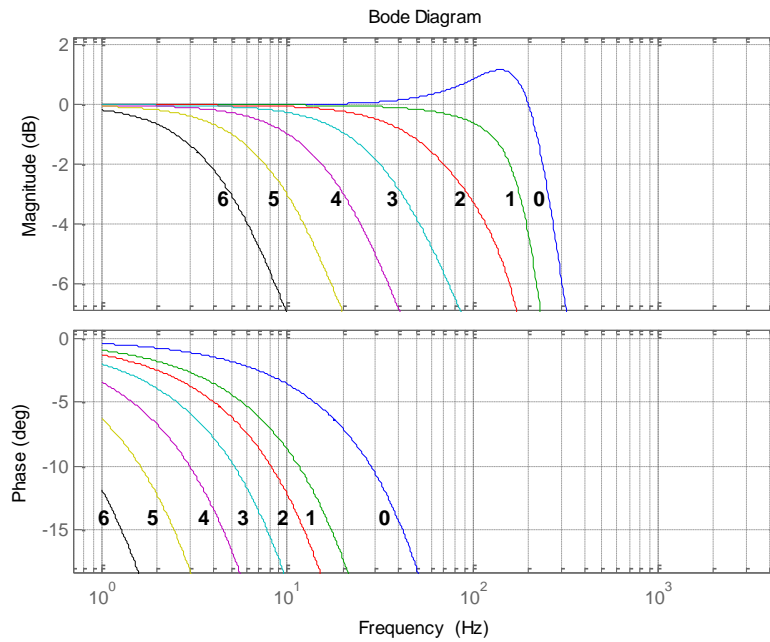

**Gain and Phase vs. Digital Filter Setting, Showing Passband Details**



## 8.4 Register 23 – Interrupt Configuration

### Type: Read/Write

Register (Hex)	Register (Decimal)	Bit7	Bit6	Bit5	Bit4	Bit3	Bit2	Bit1	Bit0	Default Value
17	23	ACTL	OPEN	LATCH_INT_EN	INT_ANYRD_2CLEAR	0	ITG_RDY_EN	0	RAW_RDY_EN	00h

### Description:

This register configures the interrupt operation of the device. The interrupt output pin (INT) configuration can be set, the interrupt latching/clearing method can be set, and the triggers for the interrupt can be set.

Note that if the application requires reading every sample of data from the ITG-3200 part, it is best to enable the raw data ready interrupt (*RAW\_RDY\_EN*). This allows the application to know when new sample data is available.

### Parameters:

<i>ACTL</i>	Logic level for INT output pin – 1=active low, 0=active high
<i>OPEN</i>	Drive type for INT output pin – 1=open drain, 0=push-pull
<i>LATCH_INT_EN</i>	Latch mode – 1=latch until interrupt is cleared, 0=50us pulse
<i>INT_ANYRD_2CLEAR</i>	Latch clear method – 1=any register read, 0=status register read only
<i>ITG_RDY_EN</i>	Enable interrupt when device is ready (PLL ready after changing clock source)
<i>RAW_RDY_EN</i>	Enable interrupt when data is available
0	Load zeros into Bits 1 and 3 of the Interrupt Configuration register.

## 8.5 Register 26 – Interrupt Status

### Type: Read only

Register (Hex)	Register (Decimal)	Bit7	Bit6	Bit5	Bit4	Bit3	Bit2	Bit1	Bit0	Default Value
1A	26	-	-	-	-	-	ITG_RDY	-	RAW_DATA_RDY	00h

### Description:

This register is used to determine the status of the ITG-3200 interrupts. Whenever one of the interrupt sources is triggered, the corresponding bit will be set. The polarity of the interrupt pin (active high/low) and the latch type (pulse or latch) has no affect on these status bits.

Use the Interrupt Configuration register (23) to enable the interrupt triggers. If the interrupt is not enabled, the associated status bit will not get set.

In normal use, the *RAW\_DATA\_RDY* interrupt is used to determine when new sensor data is available in either the sensor registers (27 to 32).

Interrupt Status bits get cleared as determined by *INT\_ANYRD\_2CLEAR* in the interrupt configuration register (23).

### Parameters:

<i>ITG_RDY</i>	PLL ready
<i>RAW_DATA_RDY</i>	Raw data is ready



## 8.6 Registers 27 to 34 – Sensor Registers

### Type: Read only

Register (Hex)	Register (Decimal)	Bit7	Bit6	Bit5	Bit4	Bit3	Bit2	Bit1	Bit0
1B	27	TEMP_OUT_H							
1C	28	TEMP_OUT_L							
1D	29	GYRO_XOUT_H							
1E	30	GYRO_XOUT_L							
1F	31	GYRO_YOUT_H							
20	32	GYRO_YOUT_L							
21	33	GYRO_ZOUT_H							
22	34	GYRO_ZOUT_L							

### Description:

These registers contain the gyro and temperature sensor data for the ITG-3200 parts. At any time, these values can be read from the device; however it is best to use the interrupt function to determine when new data is available.

### Parameters:

*TEMP\_OUT\_H/L* 16-bit temperature data (2's complement format)  
*GYRO\_XOUT\_H/L* 16-bit X gyro output data (2's complement format)  
*GYRO\_YOUT\_H/L* 16-bit Y gyro output data (2's complement format)  
*GYRO\_ZOUT\_H/L* 16-bit Z gyro output data (2's complement format)

## 8.7 Register 62 – Power Management

### Type: Read/Write

Register (Hex)	Register (Decimal)	Bit7	Bit6	Bit5	Bit4	Bit3	Bit2	Bit1	Bit0	Default Value
3E	62	H_RESET	SLEEP	STBY_XG	STBY_YG	STBY_ZG	CLK_SEL			00h

### Description:

This register is used to manage the power control, select the clock source, and to issue a master reset to the device.

Setting the *SLEEP* bit in the register puts the device into very low power sleep mode. In this mode, only the serial interface and internal registers remain active, allowing for a very low standby current. Clearing this bit puts the device back into normal mode. To save power, the individual standby selections for each of the gyros should be used if any gyro axis is not used by the application.

The *CLK\_SEL* setting determines the device clock source as follows:

### CLK\_SEL

CLK_SEL	Clock Source
0	Internal oscillator
1	PLL with X Gyro reference
2	PLL with Y Gyro reference
3	PLL with Z Gyro reference
4	PLL with external 32.768kHz reference
5	PLL with external 19.2MHz reference
6	Reserved
7	Reserved

On power up, the ITG-3200 defaults to the internal oscillator. It is highly recommended that the device is configured to use one of the gyros (or an external clock) as the clock reference, due to the improved stability.



## ITG-3200 Product Specification

Document Number: PS-ITG-3200A-00-01.4  
Revision: 1.4  
Release Date: 03/30/2010

### **Parameters:**

*H\_RESET*

Reset device and internal registers to the power-up-default settings

*SLEEP*

Enable low power sleep mode

*STBY\_XG*

Put gyro X in standby mode (1=standby, 0=normal)

*STBY\_YG*

Put gyro Y in standby mode (1=standby, 0=normal)

*STBY\_ZG*

Put gyro Z in standby mode (1=standby, 0=normal)

*CLK\_SEL*

Select device clock source

## 9 Assembly

### 9.1 Orientation

The diagram below shows the orientation of the axes of sensitivity and the polarity of rotation.

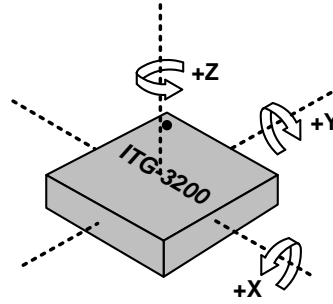

**Orientation of Axes of Sensitivity  
and Polarity of Rotation**

9.2 Package Dimensions

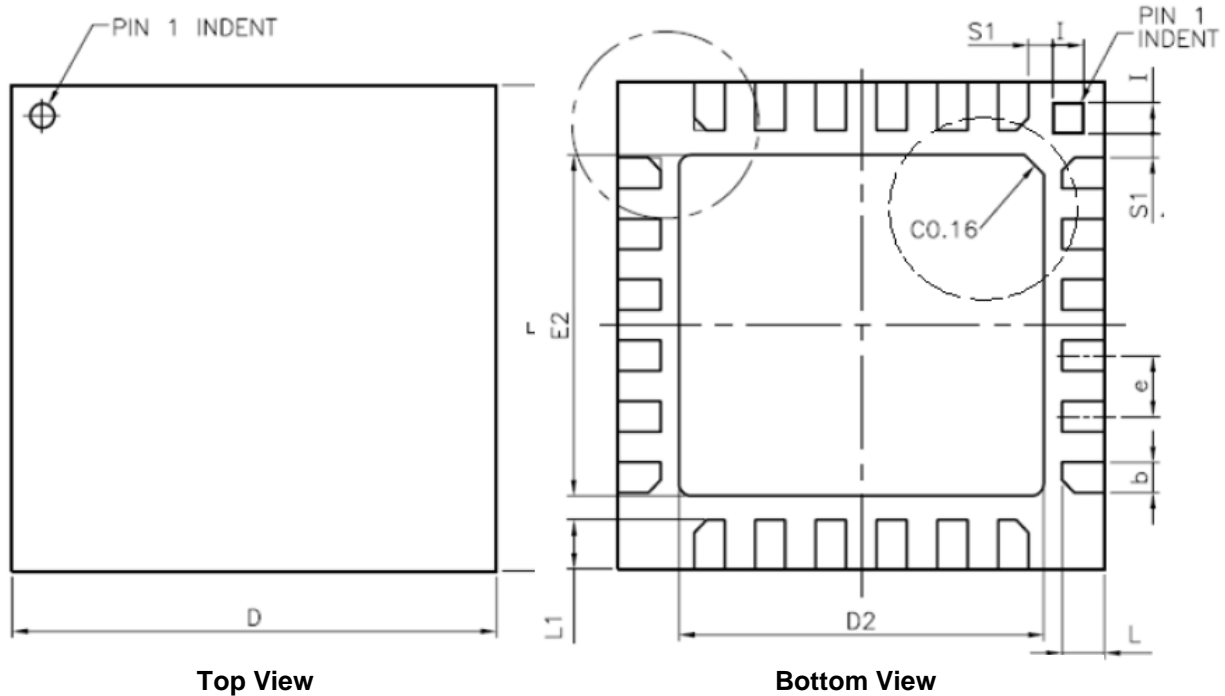

SYMBOLS	DIMENSIONS IN MILLIMETERS		
	MIN	NOM	MAX
A	0.85	0.90	0.95
A1	0.00	0.02	0.05
b	0.18	0.25	0.30
c	---	0.20 REF.	---
D	3.90	4.00	4.10
D2	2.95	3.00	3.05
E	3.90	4.00	4.10
E2	2.75	2.80	2.85
e	---	0.50	---
L	0.30	0.35	0.40
L1	0.35	0.40	0.45
I	0.20	0.25	0.30
R	0.085	---	0.145
s	0.05	---	0.15
S1	0.15	0.20	0.25
y	0.00	---	0.075

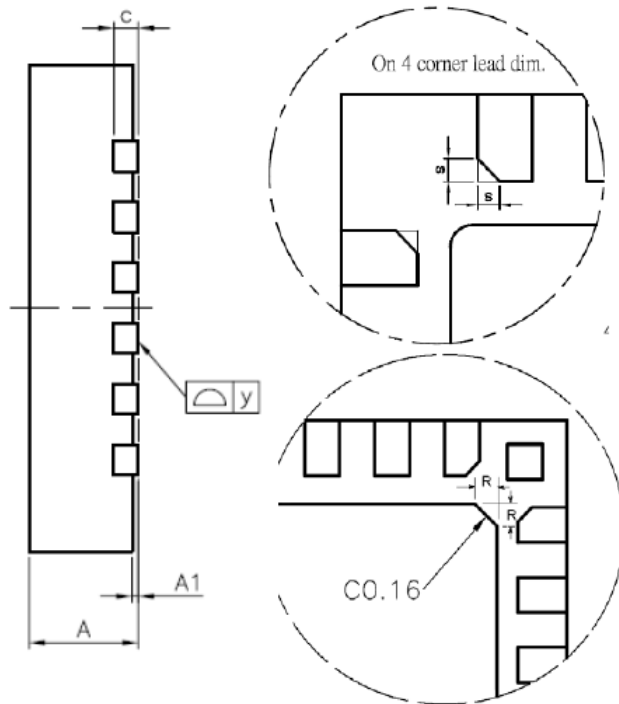

Package Dimensions

9.3 Package Marking Specification

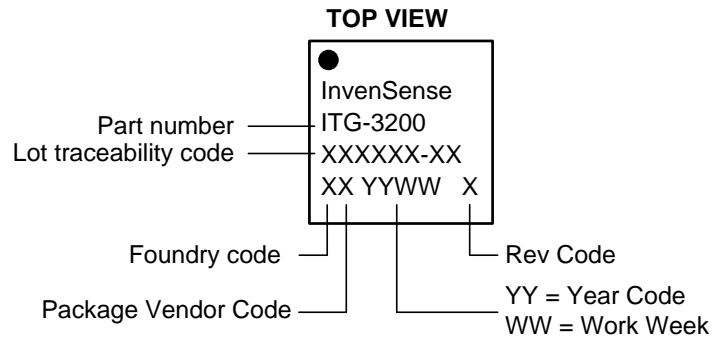

Package Marking Specification

9.4 Tape & Reel Specification

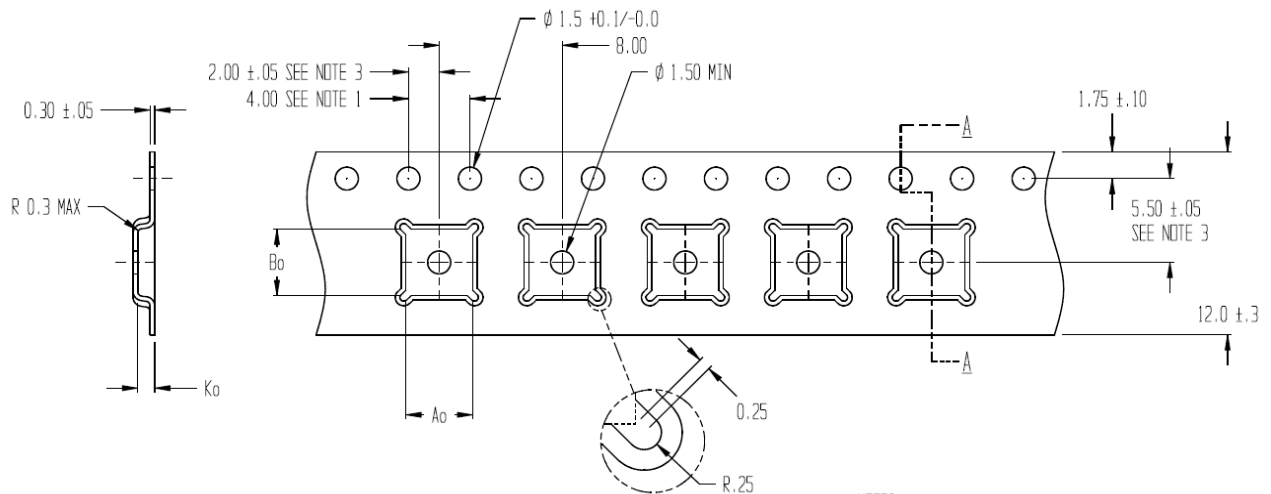

SECTION A - A

Ao = 4.35  
 Bo = 4.35  
 Ko = 1.1

TOLERANCES - UNLESS NOTED 1PL ±.2 2PL ±.10

ALL DIMENSIONS IN MILLIMETERS

NOTES:

1. 10 SPROCKET HOLE PITCH CUMULATIVE TOLERANCE ±0.2
2. CAMBER IN COMPLIANCE WITH EIA 481
3. POCKET POSITION RELATIVE TO SPROCKET HOLE MEASURED AS TRUE POSITION OF POCKET, NOT POCKET HOLE

Tape Dimensions

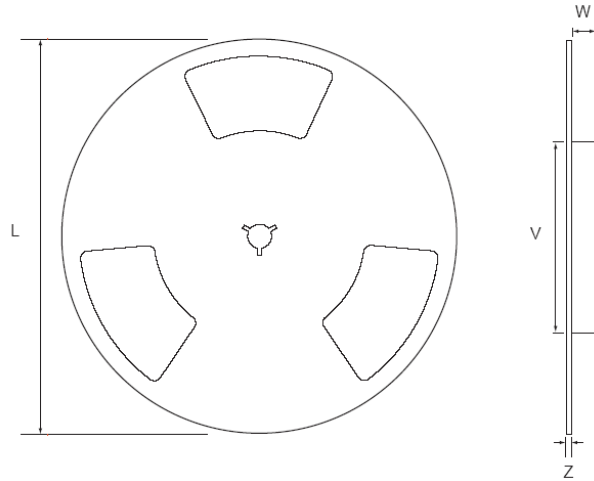

Reel Outline Drawing

Reel Dimensions and Package Size

PKG SIZE	REEL (mm)			
	L	V	W	Z
4x4	330	100	13.2	2.2

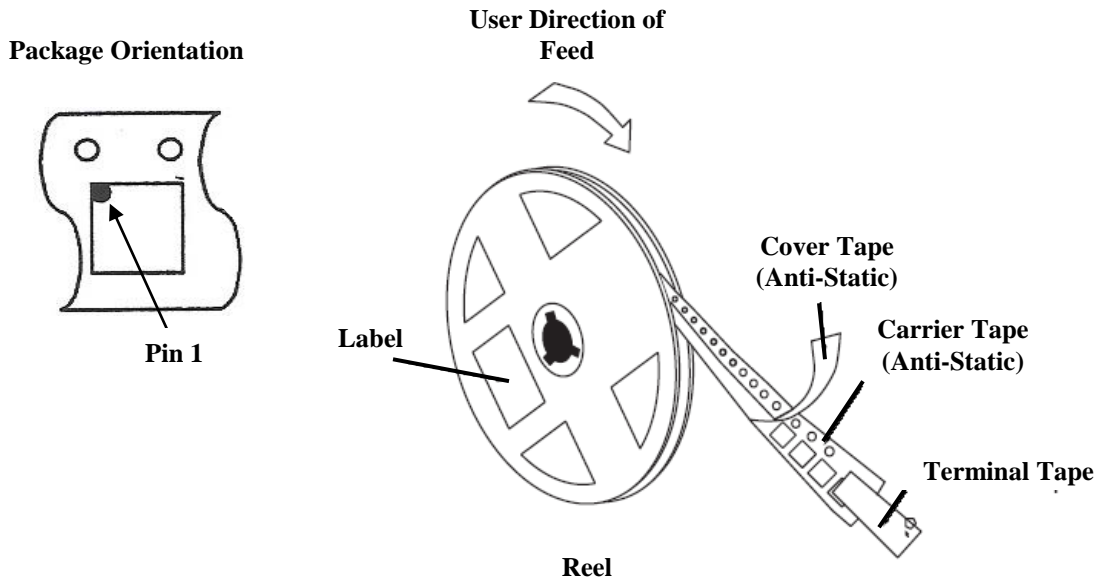

Tape and Reel Specification

Reel Specifications

Quantity Per Reel	5,000
Reels per Box	1
Boxes Per Carton (max)	3 full pizza boxes packed in the center of the carton, buffered by two empty pizza boxes (front and back).
Pcs/Carton (max)	15,000



9.5 Label

<b>InvenSense</b>		
DEVICE (IP) : ITG-3200	P.O.:	REEL QTY (Q) : 5000
LOT 1 (1T) : 123456-A	D/C (D) : 1234	QTY (Q) : 5000
LOT 2 (1T) :	D/C (D) :	QTY (Q) :
Reel Date : 13/10/09		QC STAMP

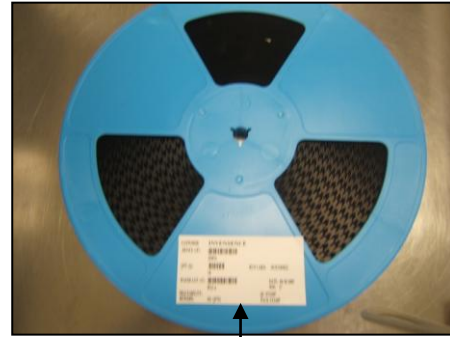

Location of Label

9.6 Packaging



- ← Anti-static Label
- ← Moisture-Sensitive Caution Label
- ← Tape & Reel Label

Moisture Barrier Bag With Labels

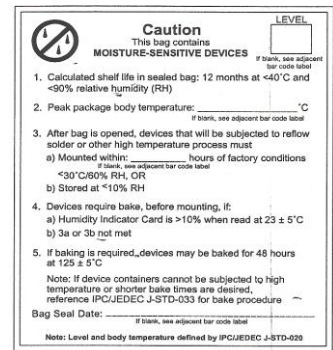

Moisture-Sensitive Caution Label



Reel in Box



Box with Tape & Reel Label

**9.7 Soldering Exposed Die Pad**

The ITG-3200 has very low active and standby current consumption. The exposed die pad is not required for heat sinking, and should not be soldered to the PCB since soldering to it contributes to performance changes due to package thermo-mechanical stress.

**9.8 Component Placement**

Testing indicates that there are no specific design considerations other than generally accepted industry design practices for component placement near the ITG-3200 multi-axis gyroscope to prevent noise coupling, and thermo-mechanical stress.

**9.9 PCB Mounting and Cross-Axis Sensitivity**

Orientation errors of the gyroscope mounted to the printed circuit board can cause cross-axis sensitivity in which one gyro responds to rotation about another axis, for example, the X-axis gyroscope responding to rotation about the Y or Z axes. The orientation mounting errors are illustrated in the figure below.

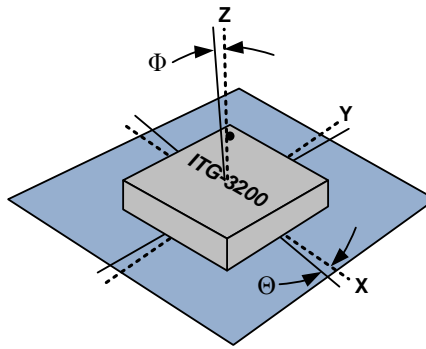

Package Gyro Axes ( ..... ) Relative to PCB Axes ( ——— ) with Orientation Errors (Θ and Φ)

The table below shows the cross-axis sensitivity as a percentage of the specified gyroscope’s sensitivity for a given orientation error.

**Cross-Axis Sensitivity vs. Orientation Error**

Orientation Error (θ or Φ)	Cross-Axis Sensitivity (sinθ or sinΦ)
0°	0%
0.5°	0.87%
1°	1.75%

The specification for cross-axis sensitivity in Section 3 includes the effect of the die orientation error with respect to the package.



### 9.10 MEMS Handling Instructions

MEMS (Micro Electro-Mechanical Systems) are a time-proven, robust technology used in hundreds of millions of consumer, automotive and industrial products. MEMS devices consist of microscopic moving mechanical structures. They differ from conventional IC products even though they can be found in similar packages. Therefore, MEMS devices require different handling precautions than conventional ICs prior to mounting onto printed circuit boards (PCBs).

The ITG-3200 gyroscope has a shock tolerance of 10,000g. InvenSense packages its gyroscopes as it deems proper for protection against normal handling and shipping. It recommends the following handling precautions to prevent potential damage.

- Individually packaged or trays of gyroscopes should not be dropped onto hard surfaces. Components placed in trays could be subject to *g*-forces in excess of 10,000g if dropped.
- Printed circuit boards that incorporate mounted gyroscopes should not be separated by manually snapping apart. This could also create *g*-forces in excess of 10,000g.

### 9.11 Gyroscope Surface Mount Guidelines

Any material used in the surface mount assembly process of the MEMS gyroscope should be free of restricted RoHS elements or compounds. Pb-free solders should be used for assembly.

In order to assure gyroscope performance, several industry standard guidelines need to be considered for surface mounting. These guidelines are for both printed circuit board (PCB) design and surface mount assembly and are available from packaging and assembly houses.

When using MEMS gyroscope components in plastic packages, package stress due to PCB mounting and assembly could affect the output offset and its value over a wide range of temperatures. This is caused by the mismatch between the Coefficient Temperature Expansion (CTE) of the package material and the PCB. Care must be taken to avoid package stress due to mounting.

### 9.12 Reflow Specification

The approved solder reflow curve shown in the figure below conforms to IPC/JEDEC J-STD-020D.01 (Moisture/Reflow Sensitivity Classification for Nonhermetic Solid State Surface Mount Devices) with a maximum peak temperature ( $T_c = 260^\circ\text{C}$ ). This is specified for component-supplier reliability qualification testing using lead-free solder for package thicknesses less than 1.6 mm. The reliability qualification pre-conditioning used by InvenSense incorporates three of these conforming reflow cycles. All temperatures refer to the topside of the QFN package, as measured on the package body surface. Customer solder-reflow processes should use the solder manufacturer's recommendations, making sure to never exceed the constraints listed in the table and figure below, as these represent the maximum tolerable ratings for the device. For optimum results, production solder reflow processes should use lower temperatures, reduced exposure times to high temperatures, and lower ramp-up and ramp-down rates than those listed below.

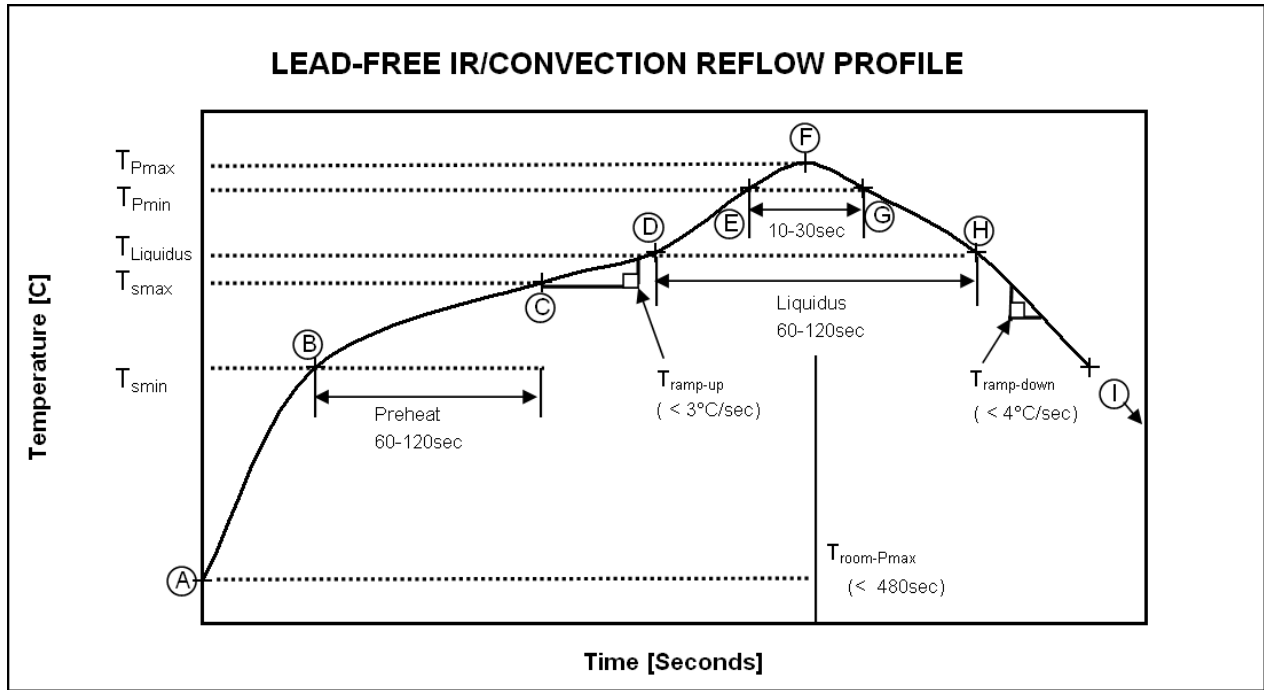

**Approved IR/Convection Solder Reflow Curve**

**Temperature Set Points for IR / Convection Reflow Corresponding to Figure Above**

Step	Setting	CONSTRAINTS		
		Temp (°C)	Time (sec)	Rate (°C/sec)
A	$T_{room}$	25		
B	$T_{Smin}$	150		
C	$T_{Smax}$	200	$60 < t_{BC} < 120$	
D	$T_{Liquidus}$	217		$r_{(TLiquidus-TPmax)} < 3$
E	$T_{Pmin}$ [< $T_{Pmax}-5^{\circ}C$ , 250°C]	255		$r_{(TLiquidus-TPmax)} < 3$
F	$T_{Pmax}$ [< $T_{Pmax}$ , 260°C]	260	$t_{AF} < 480$	$r_{(TLiquidus-TPmax)} < 3$
G	$T_{Pmin}$ [< $T_{Pmax}-5^{\circ}C$ , 250°C]	255	$t_{EG} < 30$	$r_{(TPmax-TLiquidus)} < 4$
H	$T_{Liquidus}$	217	$60 < t_{DH} < 120$	
I	$T_{room}$	25		



## ITG-3200 Product Specification

Document Number: PS-ITG-3200A-00-01.4  
Revision: 1.4  
Release Date: 03/30/2010

### 9.13 Storage Specifications

The storage specification of the ITG-3200 gyroscope conforms to IPC/JEDEC J-STD-020C Moisture Sensitivity Level (MSL) 3.

#### Storage Specifications for ITG-3200

Calculated shelf-life in moisture-sealed bag	12 months -- Storage conditions: $<40^{\circ}\text{C}$ and $<90\% \text{ RH}$
After opening moisture-sealed bag	168 hours -- Storage conditions: ambient $\leq 30^{\circ}\text{C}$ at 60% RH



## 10 Reliability

### 10.1 Qualification Test Policy

InvenSense's products complete a Qualification Test Plan before being released to production. The Qualification Test Plan follows the JEDEC 47D Standards, "Stress-Test-Driven Qualification of Integrated Circuits," with the individual tests described below.

### 10.2 Qualification Test Plan

#### Accelerated Life Tests

TEST	Method/Condition	Lot Quantity	Sample / Lot	Acc / Reject Criteria
<b>High Temperature Operating Life (HTOL/LFR)</b>	JEDEC JESD22-A108C, Dynamic, 3.63V biased, $T_j > 125^\circ\text{C}$ [read-points 168, 500, 1000 hours]	3	77	(0/1)
<b>Steady-State Temperature Humidity Bias Life <sup>(1)</sup></b>	JEDEC JESD22-A101C, 85°C/85%RH [read-points 168, 500 hours], Information Only 1000 hours]	3	77	(0/1)
<b>High Temperature Storage Life</b>	JEDEC JESD22-A103C, Cond. A, 125°C Non-Bias Bake [read-points 168, 500, 1000 hours]	3	77	(0/1)

#### Device Component Level Tests

TEST	Method/Condition	Lot Quantity	Sample / Lot	Acc / Reject Criteria
<b>ESD-HBM</b>	JEDEC JESD22-A114F, Class 2 (1.5KV)	1	3	(0/1)
<b>ESD-MM</b>	JEDEC JESD22-A115-A, Class B (200V)	1	3	(0/1)
<b>Latch Up</b>	JEDEC JESD78B Level 2, 125C, +/- 100mA	1	6	(0/1)
<b>Mechanical Shock</b>	JEDEC JESD22-B104C, Mil-Std-883, method 2002, Cond. D, 10,000g's, 0.3ms, ±X,Y,Z – 6 directions, 5 times/direction	3	5	(0/1)
<b>Vibration</b>	JEDEC JESD22-B103B, Variable Frequency (random), Cond. B, 5-500Hz, X,Y,Z – 4 times/direction	3	5	(0/1)
<b>Temperature Cycling <sup>(1)</sup></b>	JEDEC JESD22-A104D Condition N, -40°C to +85°C, Soak Mode 2, 100 cycles	3	77	(0/1)

#### Board Level Tests

TEST	Method/Condition/	Lot Quantity	Sample / Lot	Acc / Reject Criteria
<b>Board Mechanical Shock</b>	JEDEC JESD22-B104C, Mil-Std-883, method 2002, Cond. D, 10,000g's, 0.3ms, +X,Y,Z – 6 directions, 5 times/direction	1	5	(0/1)
<b>Board T/C</b>	JEDEC JESD22-A104D Condition N, -40°C to +85°C, Soak Mode 2, 100 cycles	1	40	(0/1)

(1) – Tests are preceded by MSL3 Preconditioning in accordance with JEDEC JESD22-A113F