



# G5 K '7 ca dcbYbhg

Öã ãæ/Àæ [ { ^cã&Á !^••^ !^Á^ } • [ !  
 T ã ãæ !^Á^ } • [ !•

Series/Type: H) ( \$\$

The following products presented in this data sheet are being withdrawn.

Ordering Code	Substitute Product	Date of Withdrawal	Deadline Last Orders	Last Shipments
BH		2013-10-11	2013-01-31	2013-04-30

For further information please contact your nearest EPCOS sales office, which will also support you in selecting a suitable substitute. The addresses of our worldwide sales network are presented at [www.epcos.com/sales](http://www.epcos.com/sales).

Digital barometric pressure sensor

Preliminary data



Applications

- Barometers / weather forecast
- Altimeters
- GPS receivers
- Mobile phones
- Hard disk drives
- Sensor nodes
- Variometers / vertical velocity indication



Features

- Surface Mounted Technology (SMT)
- Pressure range from 300 hPa to 1100 hPa
- Supply voltage of 1.7 V to 3.6 V
- Low current consumption
- Very small size of 2.78 mm × 2.23 mm
- Very low height of typically 0.67 mm
- Pressure inlet port on the bottom side
- Operating temperature range of -30 °C to +85 °C
- High power supply rejection
- I<sup>2</sup>C and SPI interface
- 16 bit ADC
- Internal oscillator
- RoHS compatible

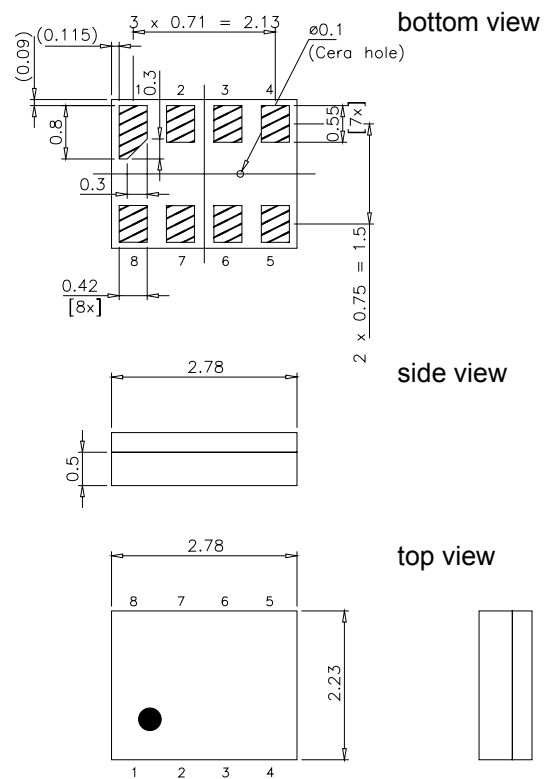

Pin configuration

Pin	Name	I/O	Function in I <sup>2</sup> C mode	Function in SPI mode
1	VDD	Supply	Supply voltage	Supply voltage
2	SEL	I	Interface protocol selection	Interface protocol selection
3	GND	Supply	Ground supply	Ground supply
4	EOC	O	End of conversion	End of conversion
5	RST&SS	I	Reset	Slave select
6	MISO	O	High impedance	Master In Slave Out (MISO)
7	SDA/MOSI	I/O	I <sup>2</sup> C data signal	Master Out Slave In (MOSI)
8	SCL/SCLK	I	I <sup>2</sup> C clock signal	SPI clock signal

**Digital barometric pressure sensor**

Preliminary data

**General description**

The T5400 is a fully calibrated digital pressure sensor. Based on the proven EPCOS piezoresistive MEMS technology the sensor module provides high accuracy and long-term stability. The very small size of only 2.78 mm × 2.23 mm and the low current consumption allows the integration into a multitude of mobile and stationary applications like personal navigation devices, mobile phones, altimeters and hard disk drives. Two high speed serial interfaces, I<sup>2</sup>C (3.4 MHz) and SPI (20 MHz), offer a high flexibility to connect the T5400 to almost every microcontroller platform.

After initialisation calibration coefficients need to be transferred from the sensor memory to the microcontroller. Afterwards the sensor transmits the raw pressure and temperature readings on request. The user can select between four different operating modes from 5.1 Pa (0.42 m) to 2.7 Pa (0.22 m) RMS noise. The calculation of the actual pressure and altitude is done by the microcontroller.

**Electrical characteristics**

Temperature range for specification unless otherwise noted:

$$T = -30\text{ °C} \dots +85\text{ °C}$$

Ambient temperature of test conditions:

$$T_A = 25\text{ °C}$$

Supply voltage:

$$V_{DD} = 1.8\text{ V}$$

All voltages refer to ground.

		Min.	Typ.	Max.	Unit	Note or condition
<b>Current consumption<sup>1)</sup></b>	I <sub>IDLE</sub>	—	0.15	0.3	μA	−30 °C ... 25 °C
		—	1	—	μA	25 °C ... 70 °C
		—	3	—	μA	70 °C ... 85 °C
	I <sub>PEAK_P</sub>	—	790	—	μA	during pressure measurement <sup>2)</sup>
	I <sub>PEAK_T</sub>	—	500	—	μA	during temperature measurement <sup>2)</sup>
<b>Pressure range</b>	p	300	—	1100	hPa	
<b>Resolution pressure reading</b>		—	2.9	—	Pa	
<b>Absolute accuracy pressure sensor<sup>3)</sup></b>	Δp	−3	−1	+2	hPa	p = 300 hPa ... 1100 hPa T = 0 °C ... 65 °C
		−3	0	+5	hPa	p = 300 hPa ... 1100 hPa T = −20 °C ... 0 °C
<b>Relative accuracy pressure sensor<sup>3)</sup></b>	Δp	—	± 0.15	—	hPa	p = 950 hPa ... 1050 hPa T = 25 °C
		—	± 0.14	—	hPa	T = 25 °C ... 40 °C p <sub>const</sub> = 500 hPa ... 1100 hPa <sup>4)</sup>

**Digital barometric pressure sensor**
**Preliminary data**

	Min.	Typ.	Max.	Unit	Note or condition
<b>Resolution temperature reading</b>	—	0.01	—	K	
<b>Absolute accuracy temperature sensor<sup>3)</sup></b> $\Delta T$	-1.5	$\pm 0.5$	+1.5	K	T = 25°C
	-2	$\pm 1$	+2	K	T = 0°C ... 70 °C
<b>Solder drift<sup>3)</sup></b>	-1	—	+3	hPa	after one week

1) Ensured by design.

2) Without interface activity.

3) Specified during qualification. Given values are  $\pm 3\sigma$  values for new parts; solder drift is shown separately.

4) Relative accuracy over temperature at constant pressure in the range of 500 hPa ... 1100 hPa

	Min.	Typ.	Max.	Unit	Note or condition
<b>Power supply rejection<sup>1)</sup></b>	—	1.4	—	hPa	Normal operation $V_{DD} = 1.7 \text{ V} \dots 3.6 \text{ V}$
	—	8.7	—	Pa	100 mV <sub>P-P</sub> , 217 Hz square wave plus 100 mV random noise in 10 MHz bandwidth
<b>Start-up time</b> $t_S$	—	—	10	ms	Delay between power on and first serial communication
<b>Wake-up time</b> $t_{WU}$	—	2	2.5	ms	Wake up time from idle mode to start of first measurement

1) Ensured by design.

**Operation modes**

	typ. RMS noise <sup>1)</sup> (Pa)	typ. RMS noise (m)	Avg. current @ 1SPS <sup>2)</sup> (μA)	Typ. Conversion time (ms) <sup>3)</sup>	Max. Conversion time (ms) <sup>3)</sup>
Temperature			1.6	1.4	2
Low	5.1	0.42	2.6	1.4	2
Standard	3.5	0.29	7.2	7.3	8
High	3.2	0.27	13.3	15.2	16
Ultra high <sup>4)</sup>	2.7	0.22	51.3	63.8	66

1) The noise data is derived from the standard deviation of ten successive samples.

2) Samples per second, typical conversion times, including wake-up phase.

3) excluding wake-up time.

4) Requires the average of two temperature measurements: one before and one after the pressure measurement.

**Digital barometric pressure sensor**

Preliminary data

**Absolute maximum ratings**

		<b>Min.</b>	<b>Max.</b>	<b>Unit</b>	<b>Note or condition</b>
Operable temperature range	T	-30	+85	°C	
Storage temperature range	T <sub>STG</sub>	-40	+85	°C	
Storage temperature range	T <sub>STGT</sub>	0	+60	°C	stored in tape
Operable power supply voltage	V <sub>DD</sub>	1.7	3.6	V	V <sub>DD,min</sub> already includes influence of ripples and noise
Power supply voltage	V <sub>DD</sub>	-0.3	4.25	V	below T = 25 °C the minimum supply voltage is V <sub>DD</sub> = -0.4 V
Voltage at any digital pad	V <sub>pad</sub>	V <sub>SS</sub> -0.3	V <sub>DD</sub> +0.3	V	The voltage must stay within the above specified V <sub>DD</sub> range
Overpressure	P <sub>MAX</sub>		6000	hPa	
ESD voltage	V <sub>ESD_MM</sub>		200	V	machine model <sup>1)</sup>
ESD voltage	V <sub>ESD_HBM</sub>		2000	V	human body model <sup>2)</sup>
Latch-up		tested according to JESD78 at V <sub>DD,max</sub> and T = 25 °C			

1) According to JESD22-A115A.

2) According to JESD22-A114E.

**Digital barometric pressure sensor**

Preliminary data

**Electrical interface characteristics**

		Min.	Typ.	Max.	Unit	Comment
External capacitance between $V_{DD}$ and GND	$C_{VDD}$	90	—	—	nF	
Capacitances of I/O pins	$C_{IO}$	—	—	10	pF	
Voltage input low level	$V_{IL}$	—	0	$0.3 \cdot V_{DD}$	V	
Voltage input high level	$V_{IH}$	$0.7 \cdot V_{DD}$	$V_{DD}$	—	V	
Voltage output low level	$V_{OL}$	—	0	$0.2 \cdot V_{DD}$	V	$I_{OL} = 1\text{mA}$
Voltage output high level	$V_{OH}$	$0.8 \cdot V_{DD}$	$V_{DD}$	—	V	$I_{OH} = 1\text{mA}$

The T5400 can be operated either in I<sup>2</sup>C or SPI slave mode. Depending on the logic level of the SEL pad, the I<sup>2</sup>C mode (SEL=high) or the SPI mode (SEL=low) is selected.

**I<sup>2</sup>C mode**

The I<sup>2</sup>C interface is compatible to NXP specification UM10204, Rev. 03, June 19, 2007. Standard, fast, fast plus and high-speed modes are supported.

		Min.	Typ.	Max.	Unit	Comment
SCL clock frequency	$f_{SCL}$	—	—	3.4	MHz	Standard, fast, fast-plus and Hs-mode
Voltage output low level	$V_{OL}$	—	0	$0.2 \cdot V_{DD}$	V	$I_{OL} = 3\text{mA}$
Pull-up resistor on SDA and SCL	$R_{PU}$	1	4.7	—	k $\Omega$	
Capacitive load for each bus line		—	—	100	pF	

**Digital barometric pressure sensor**

Preliminary data

**SPI mode**

		Min.	Typ.	Max.	Unit
SCLK clock frequency	$f_{SCL}$	—	—	20	MHz
SS activation time	$t_{SSA}$	21	—	—	ns
SCLK clock low time	$t_{CKL}$	21	—	—	ns
SCLK clock high time	$t_{CKH}$	21	—	—	ns
SS deactivation time	$t_{SSD}$	21	—	—	ns
MOSI setup time	$t_{DSO}$	6	—	—	ns
MISO setup time	$t_{QS}$	10	—	—	ns
MOSI hold time	$t_{DO}$	6	—	—	ns
MISO hold time	$t_{QH}$	0	—	—	ns
Maximum capacitive load	$C_{MAX}$	—	25 <sup>1)</sup>	—	pF

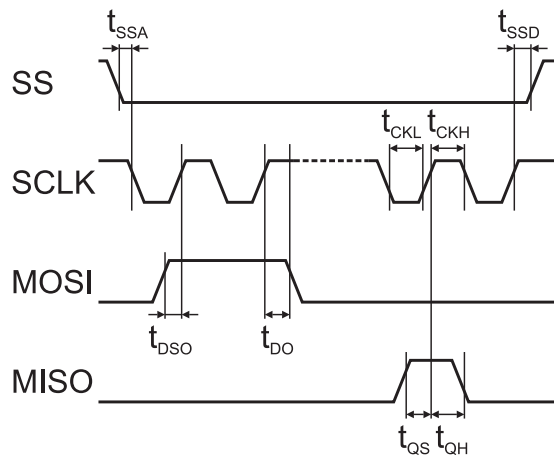
<sup>1)</sup>Typically at  $f_{SCL} = 20$  MHz.





**Digital barometric pressure sensor**

Preliminary data

**Assembly conditions**

Solder reflow profile	According to EPCOS specification S_6001
Max. number of reflows	3
Max. peak temperature	260 °C
Moisture sensitivity level	MSL 3

**Cautions and warnings**

- Immersion of the sensor in liquids e.g. a flux cleaning process is not possible.
- For optimum performance avoid direct light exposure.
- Media compatibility with the pressure sensor must be ensured. Do not expose the sensor to corrosive or explosive gases.

**Pressure conversion table**

Unit	bar	mbar	Pa	hPa	kPa	mmHg	psi
1 bar	1	1000	100000	1000	100	750.063	14.504
1 mbar	0.001	1	100	1	0.1	0.750	0.0145
1 Pa	0.00001	0.01	1	0.01	0.001	0.0075	0.000145
1 hPa	0.001	1	100	1	0.1	0.750	0.0145
1 kPa	0.01	10	1000	10	1	7.5006	0.145
1 mmHg	0.00133	1.3332	133.322	1.3332	0.13332	1	0.01933
1 psi	0.0689476	68.9476	6894.76	68.9476	6.89476	51.7151	1

**Annotations**

- bar Bar
- Pa Pascal ( $\equiv 1 \text{ N/m}^2$ )
- hPa Hecto-Pascal ( $\equiv 1 \text{ mbar}$ )
- mmHg mm column of mercury ( $\equiv 1 \text{ Torr}$ )
- psi Pounds per square inch ( $\equiv 1 \text{ lbf/in}^2$ )

**Digital barometric pressure sensor**

Preliminary data

**References**

<b>Type</b>	T5400
<b>Ordering code</b>	B39000T5400P810
<b>Marking and package</b>	C61157-A13-A1
<b>Packaging</b>	F61074-V8261-Z000
<b>Date codes</b>	L_1126
<b>Soldering profile</b>	S_6001
<b>Qualification test procedure</b>	S_0360
<b>RoHS compatible</b>	RoHS-compatible means that products are compatible with the requirements according to Art. 4 (substance restrictions) of Directive 2011/65/EU of the European Parliament and of the Council of June 8 <sup>th</sup> , 2011, on the restriction of the use of certain hazardous substances in electrical and electronic equipment ("Directive") with due regard to the application of exemptions as per Annex III of the Directive in certain cases.

For further information please contact your local EPCOS sales office or visit our webpage at [www.epcos.com](http://www.epcos.com).

**Published by EPCOS AG**  
**Systems, Acoustics, Waves Business Group**  
**P.O. Box 80 17 09, 81617 Munich, GERMANY**

© EPCOS AG 2013. This brochure replaces the previous edition.

For questions on technology, prices and delivery please contact the Sales Offices of EPCOS AG or the international Representatives.

Due to technical requirements components may contain dangerous substances. For information on the type in question please also contact one of our Sales Offices.