

SLAMTEC Mapper

Laser Mapping Sensor

Introduction and Datasheet(PREVIEW)

Model: M1M1

20M

SLAM 3.0

SharpEdge

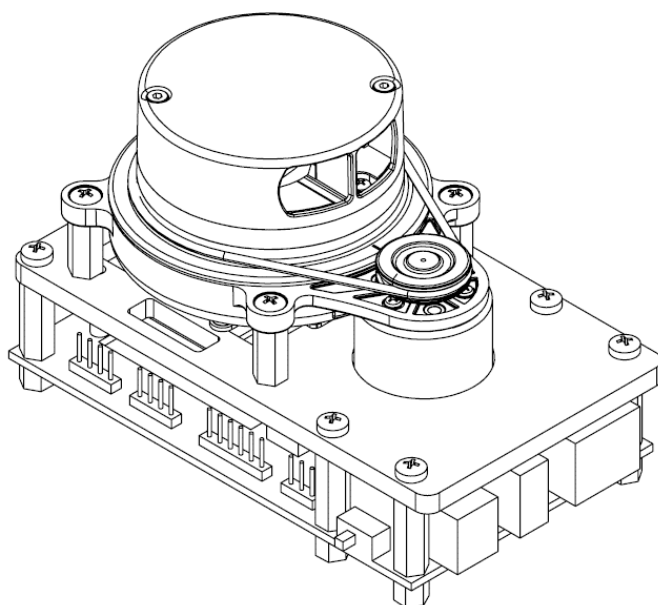

CONTENTS	1
INTRODUCTION	3
SYSTEM COMPOSITION AND CONNECTION.....	4
MECHANISM	4
SAFETY AND SCOPE.....	6
DATA OUTPUT.....	6
APPLICATION SCENARIOS.....	6
SPECIFICATION	7
MEASUREMENT PERFORMANCE	7
LASER POWER SPECIFICATION.....	7
OPTICAL WINDOW.....	8
COORDINATE SYSTEM DEFINITION OF SCANNING DATA	8
COMMUNICATION INTERFACE	9
OTHER PARAMETERS	11
SELF-PROTECTION AND STATUS DETECTION	12
SDK AND SUPPORT	13
MECHANICAL DIMENSIONS	14
REVISION HISTORY	15
APPENDIX	16
IMAGE AND TABLE INDEX.....	16

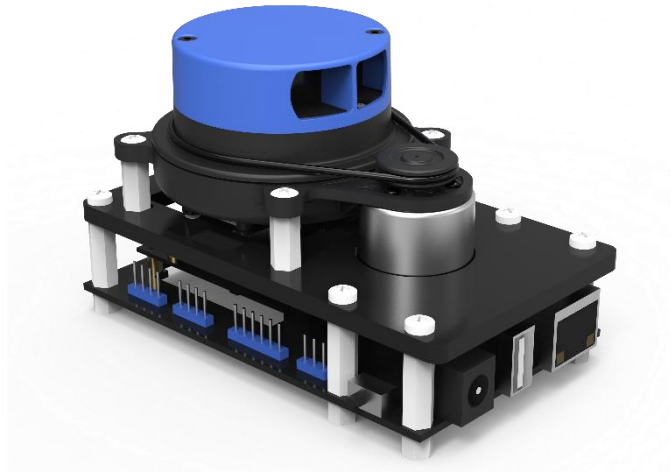

SLAMTEC Mapper is a new type of laser sensor introduced by SLAMTEC, which is different from traditional LIDAR. It has built-in functions of simultaneous localization and mapping (SLAM), and is suitable for many applications such as robot navigation and positioning, environmental mapping and hand-held measurement.

SLAMTEC Mapper uses high-performance SLAM map optimization engine and SharpEdge™ fine mapping technology, which can actively detect and correct closed-loop, and achieve 100,000 square meters high-precision map and pose.

SLAMTEC Mapper can work without additional sensors or data input. Because of the built-in 9-DOF inertial navigation system, SLAMTEC Mapper in the hand-held mapping mode can work normally in fluctuating environment with inclination, to ensure the best map data quality.

SLAMTEC Mapper provides a complete SDK development kit, mobile phone and PC-side evaluation tools to facilitate users to expand development and data acquisition. At the same time, combined with the supporting ROS driver, the generated map and pose data can be directly used in the ROS environment, which is fully compatible.

SLAMTEC Mapper can be directly used as a LIDAR sensor in addition to its own mapping and positioning functions. Through SDK or ROS node, the LIDAR data can be quickly accessed to users' existing systems.

System Composition and Connection

SLAMTEC Mapper developer kit includes LIDAR sensors and data processing units. Users only need to connect to 5V DC power supply, then with Ethernet or WiFi SLAMTEC Mapper can be easily communicated.

SLAMTEC Mapper developer kit supports DC power supply for DC sockets. Users can obtain real-time map and pose data generated by SLAMTEC Mapper through WiFi signal, and can also realize high-speed and stable data path through Ethernet interface.

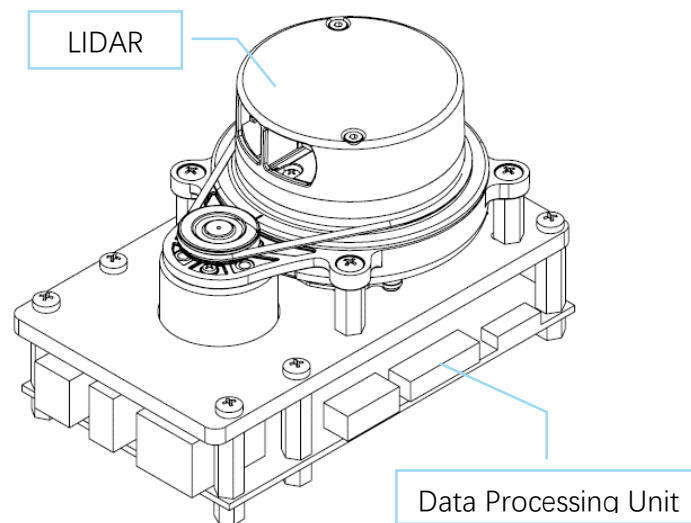

Figure 1-1 SLAMTEC Mapper System Composition

Mechanism

SLAMTEC Mapper developer kit uses SLAMTEC's unique SLAM optimization algorithm and high-performance LIDAR to fuse map data more than 10 times per second and construct up to 100,000 square meters of mapping area. The LIDAR carries out 7000 measurements per second, and the longest ranging distance can reach 20 meters. The built-in processing system can process data in real time and output high-precision map and pose.

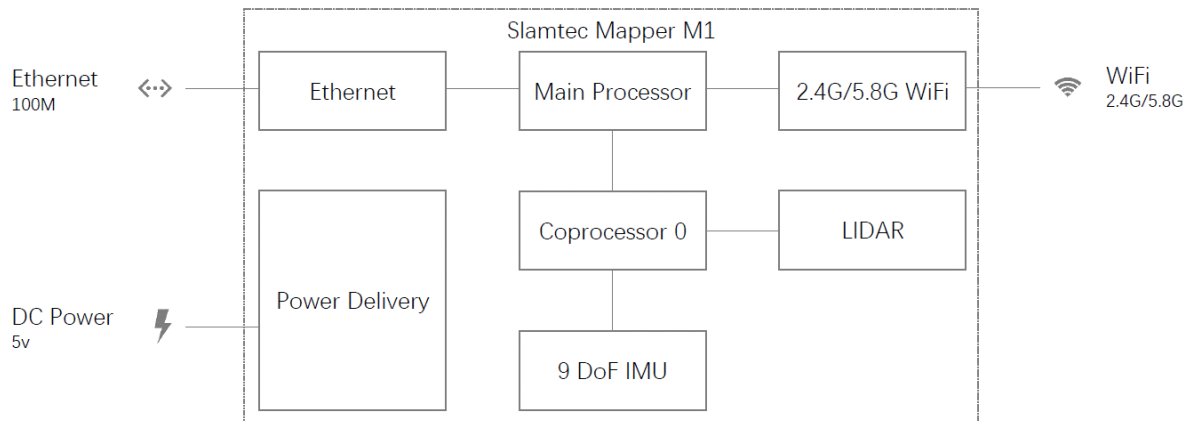

Figure 1-2 Block Diagram of working principle of SLAMTEC Mapper

Driven by the motor mechanism, the SLAMTEC Mapper's ranging core will rotate clockwise to achieve 360-degree omni-directional map of the surrounding environment.

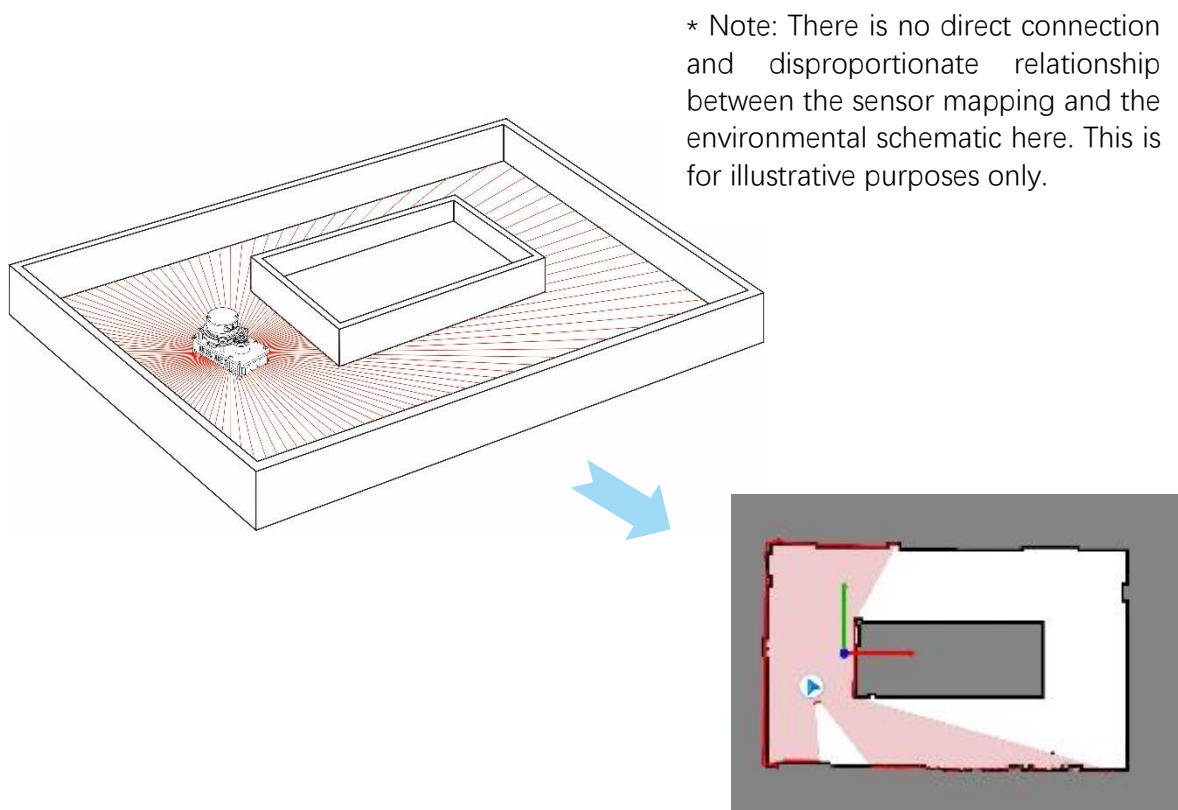

Figure 1-3 The Obtained Environment Map from SLAMTEC Mapper

Safety and Scope



Class I

SLAMTEC Mapper uses a low-power infrared laser as the emission source and is driven by a modulated pulse mode. The laser can only launch in a very short time. Therefore, it can ensure the safety of humans and pets, and can meet the Class I level of laser safety standards. The product conforms to 21 CFR 1040.10 and 1040.11, except for deviation according to Laser Notice No. 50 of 24 June 2007.

Caution: Use of controls or adjustments or performance of procedures other than those specified herein may result in hazardous radiation exposure.

The modulated laser can effectively avoid the interference from ambient light and sunlight during ranging scanning process, which makes SLAMTEC Mapper work excellent in all kinds of indoor environment and outdoor environment without direct sunlight.

Data Output

SLAMTEC Mapper developer kit can achieve 0.05m resolution and less than 0.02m positioning accuracy, and can actively detect and correct the closed-loop by using SLAMTEC's high-performance SLAM map optimization engine and SharpEdge™ fine mapping technology. The output data includes real-time LIDAR scanning data, real-time map data, real-time pose coordinates (x, y, theta) and positioning quality.

With SLAMWARE SDK or ROS Node driver, relevant data can be obtained.

Application Scenarios

SLAMTEC Mapper can be used in the following application scenarios:

- General robot navigation and localization
- Environment mapping
- Architectural engineering

Measurement Performance

For Model M1M1 Only

Item	Detail	Parameter
Distance Range ¹	The largest distance measured by radar	20m
Sample Rate	Laser points sampled per second by radar	7000 Hz
Maximum Area	Maximum Mapping Area	300m * 300m
Mapping resolution ²		0.05m
Maximum moving speed	Maximum Linear Speed of Product Mobility	1 m/s
Maximum rotation speed	Maximum angular velocity of product rotation	TBD
Accuracy		< 0.02m
Graph Optimizing Working Time ³		About 1hr
Maximum Inclination Angle	Maximum Inclination Angle in Mapping Process	±3°
Frequency of data refresh	Frequency of data and location information updates	8 Hz

Figure 2-1 SLAMTEC Mapper Performance

Laser Power Specification

For Model M1M1 Only

Item	Unit	Min	Typical	Max	Comments
Laser wavelength	Nanometer(nm)	895	905	915	Infrared Light Band
Laser power ⁴	Watt (W)	-	28	-	Peak power
Pulse length	Nanosecond(ns)	-	10	-	-
Duty Ratio			0.007		
Laser Safety Class	-	-	IEC-60825 Class 1	-	-

Figure 2-2 SLAMTEC Mapper Specification

¹ Measured at 92% reflectivity

² Each pixel in the map represents an area of 0.05m x 0.05m

³ Depending on the difference of environment, beyond the time limit, it will enter the non-graph optimization mapping mode.

⁴ Laser power is instantaneous, and the actual average power will be much lower than this value.

Optical Window

To make SLAMTEC Mapper working normally, please ensure proper space to be left for its emitting and receiving laser lights when designing the host system⁵. The obscuring of the host system for the ranging window will impact the performance and resolution of SLAMTEC Mapper. If you need cover the SLAMTEC Mapper with translucent materials or have other special needs, please contact SLAMTEC about the feasibility.

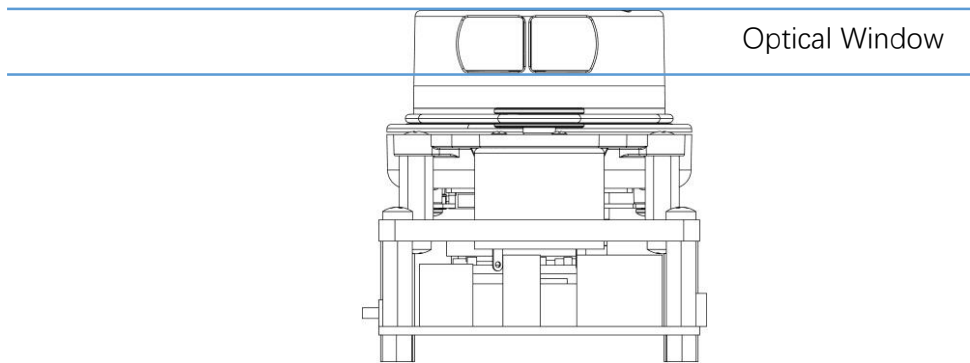

Figure 2-3 SLAMTEC Mapper Window

Coordinate System Definition of Scanning Data

SLAMTEC Mapper adopts a coordinate system that follows the right-hand rule. The front of the sensor is defined as the x-axis of the coordinate system, and the origin of the coordinate system is the rotation center of the ranging core. Specific coordinate system definitions are shown in the following figure:

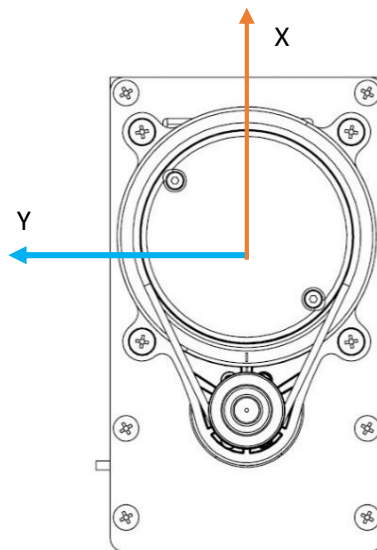

Figure 2-4 SLAMTEC Mapper Scanning Data Coordinate System Definition

⁵ You can check the Mechanical Dimensions chapter for detailed window dimensions.

Communication interface

SLAMTEC Mapper uses a separate 5V DC power supply. Through simple plug-and-play functions, users can connect it to mobile devices such as mobile phones to create an integrated portable measurement scheme.

Specific interface definitions and ontology lines are shown in the following figure:

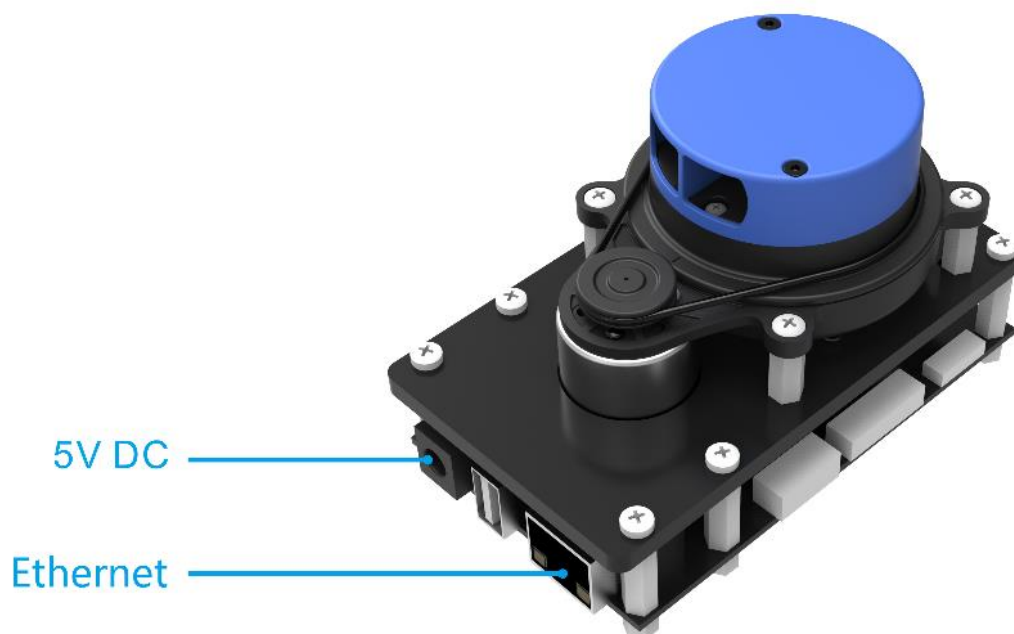

Figure 2-5 SLAMTEC Mapper Developer Kit Interface Definition Diagram



Figure 2-6 SLAMTEC Mapper Developer Kit Power Wire Diagram

Power Supply Interface

SLAMTEC Mapper developer kit supports DC power supply for DC sockets. External power supply needs to ensure that the current output ability and ripple characteristics of the power supply meet the requirements of the table below to ensure the normal use of the map sensor.

For Model M1M1 Only

Item	Unit	Min	Typical	Max	Remark
Power Voltage	V	-	5	-	If the voltage exceeds the max value, it may damage the core
Power Voltage Ripple	mV	-	20	50	High ripple may cause the core working failure.
System Start Current	mA	1400	1500	1600	
Power Current	mA	TBD	TBD	TBD	5V Power, power off
		450	500	1000	5V Power, power on

Figure 2-8 SLAMTEC Mapper Power Supply Specification

Data communication interface

SLAMTEC Mapper communicates with WiFi over Ethernet. Its transmission standards and rates are shown in the following table:

Interface	Standard	Rate
Ethernet	802.3/802.3u	10/100M
WiFi	802.11a/b/g/n/ac	-

Figure 2-9 SLAMTEC Mapper Interface Specification

Other parameters

For Model M1M1 Only

Item	Unit	Min	Typical	Max	Comments
Weight	Gram (g)	TBD	230	TBD	
Working temperature range	Degree Celsius (°C)	-5	25	45	
Storage temperature range	Degree Celsius (°C)	TBD	TBD	TBD	

Figure 2-10 SLAMTEC Mapper Other Parameters

When SLAMTEC Mapper is not working properly, users can get the working status of the system through SDK health data acquisition interface, and try to restart SLAMTEC Mapper to restore work.

In order to facilitate users to use SLAMTEC Mapper for product development and accelerate the development cycle, SLAMTEC provides RoboStudio, a software for robot management and development, which can be debugged graphically through network connection. In addition, SDK development kit which can run on X86 windows, x86 Linux, arm Linux and other platforms is also provided to users. For specific information, please contact SLAMTEC.

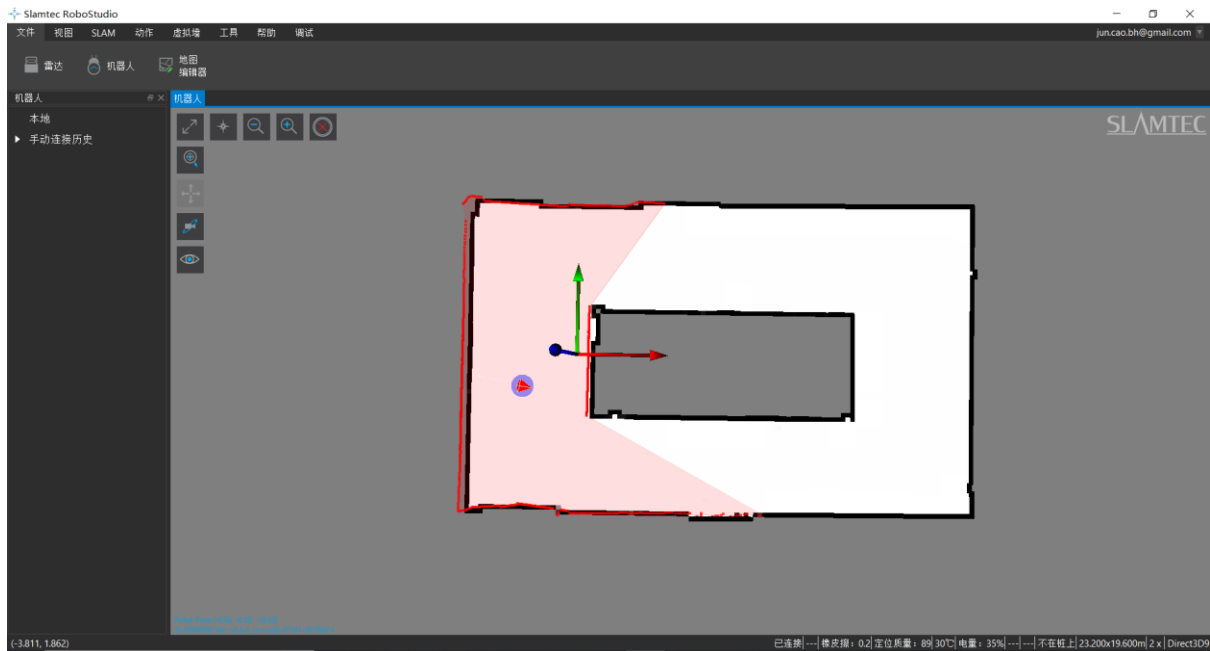

Figure 4-1 RoboStudio

The mechanical dimensions of the SLAMTEC Mapper are shown as below:

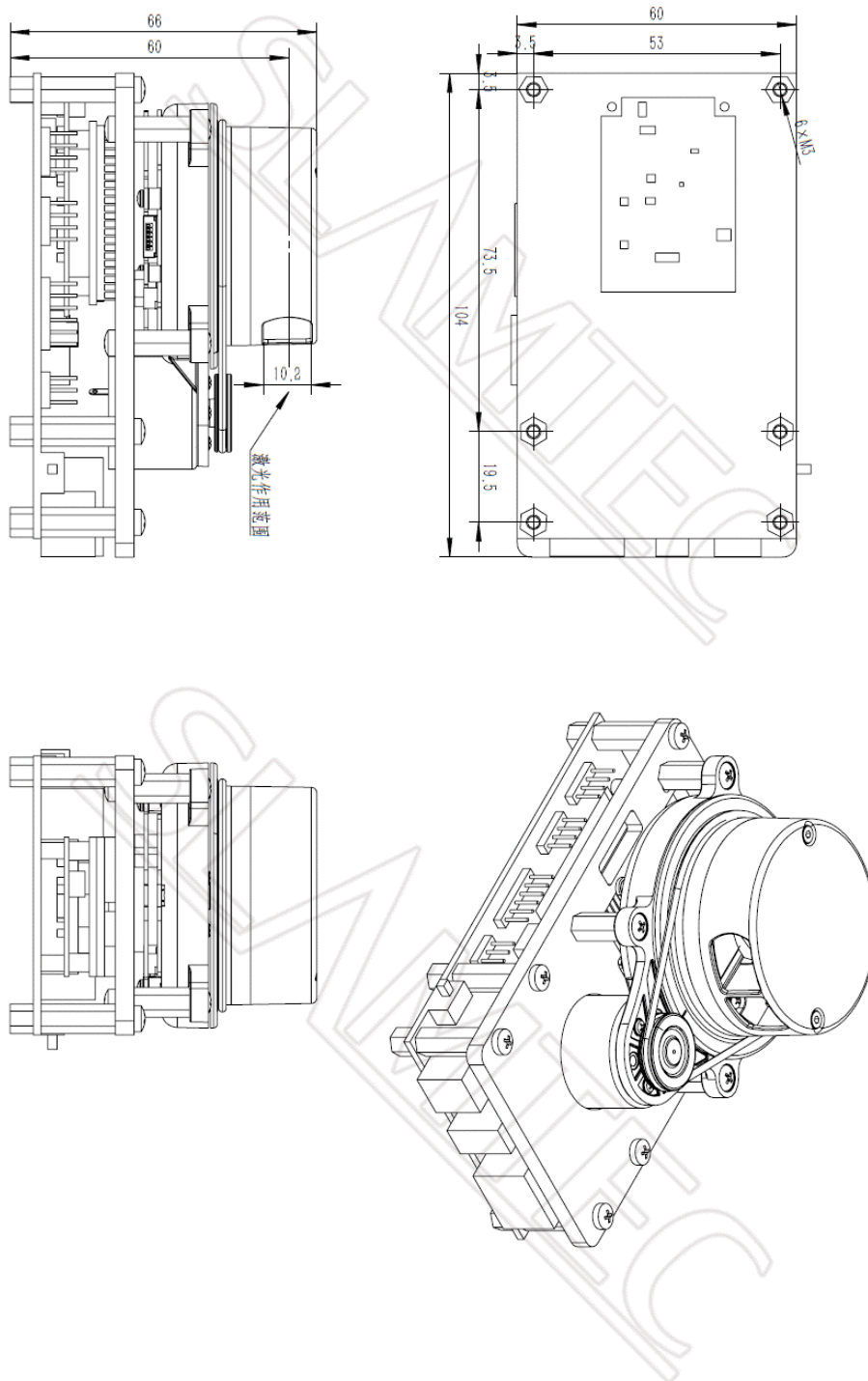

Figure 5-1 SLAMTEC Mapper Mechanical Dimensions

Date	Version	Description
2019-7-19	1.0	Initial version for SLAMTEC Mapper
2019-11-26	1.1	Added the current value of working current in Table 2-7
2019-11-29	1.2	Modify figure 2-3 SLAMTEC Mapper window