



AEC-Q200
 This component was always
 RoHS compliant from the first
 date of manufacture.

- **Hermetically sealed Surface Mount package**
- **Complies with Directive 2002/95/EC (RoHS)**



SF2423D

**480 MHz
 SAW Filter**

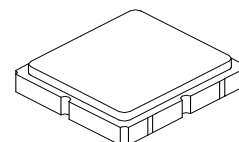

SM3838-8 Case

Absolute Maximum Ratings

Rating	Value	Units
Maximum Input Power	+10	dBm
DC Voltage	3	VDC
Operable Temperature Range	-45 to +125	°C
Specification Temperature	-40 to +85	°C
Storage Temperature	-40 to +85	°C

Electrical Characteristics

Characteristic	Sym	Notes	Minimum	Typical	Maximum	Units
Nominal Operating Frequency	f_c			480		MHz
Max Insertion Loss 470 to 490 MHz				2.0	3.0	dB
2dB Bandwidth			20	24.3		MHz
Attenuation (Reference level from 0dB)						
$f_c -100$ to $f_c -45$ MHz			40	56		dB
$f_c +45$ to $f_c +55$ MHz			30	56		
$f_c +55$ to $f_c +100$ MHz			40	54		
Temperature Coefficient of Frequency				36		ppm/k
Source Impedance	Z_S			50		Ω
Load Impedance	Z_L			50		Ω

SM3838-8

Footprint Size: 3.8 X 3.8

Lid Symbolization (Y=Year, WW=week, S=shift)

B37//YWWS

Electrical Connections

Connection	Terminals
Input	2
Output	6
Ground	All Others

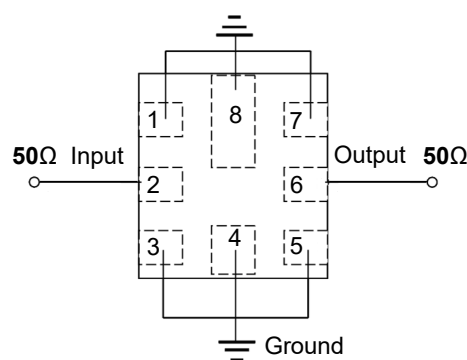

CAUTION: Electrostatic Sensitive Device. Observe precautions for handling.

NOTES:

1. The design, manufacturing process, and specifications of this device are subject to change.
2. US or International patents may apply.

Frequency Characteristics

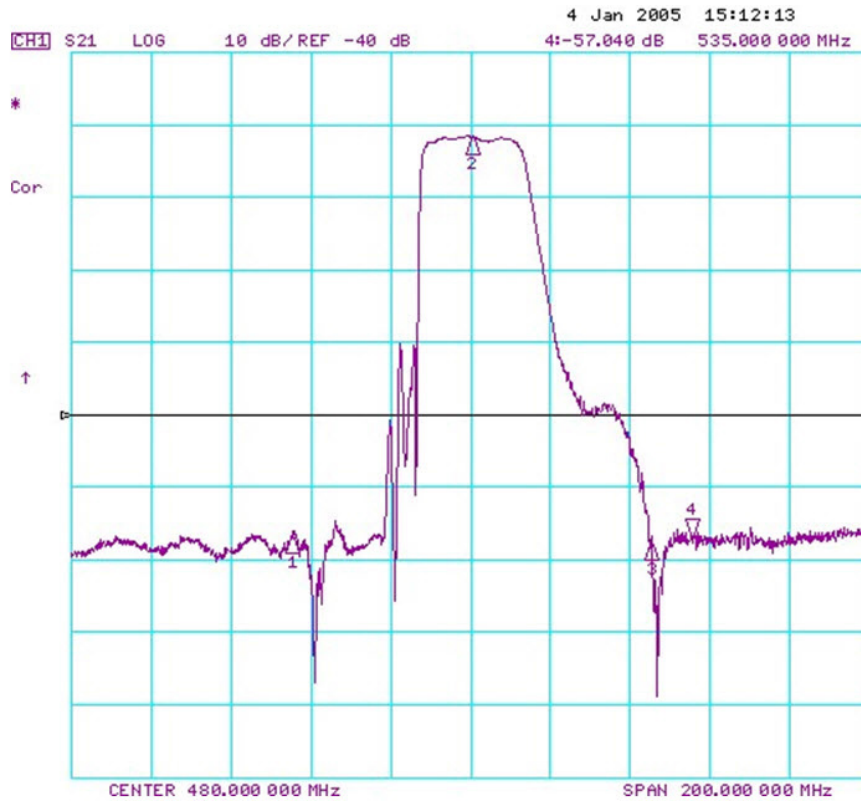
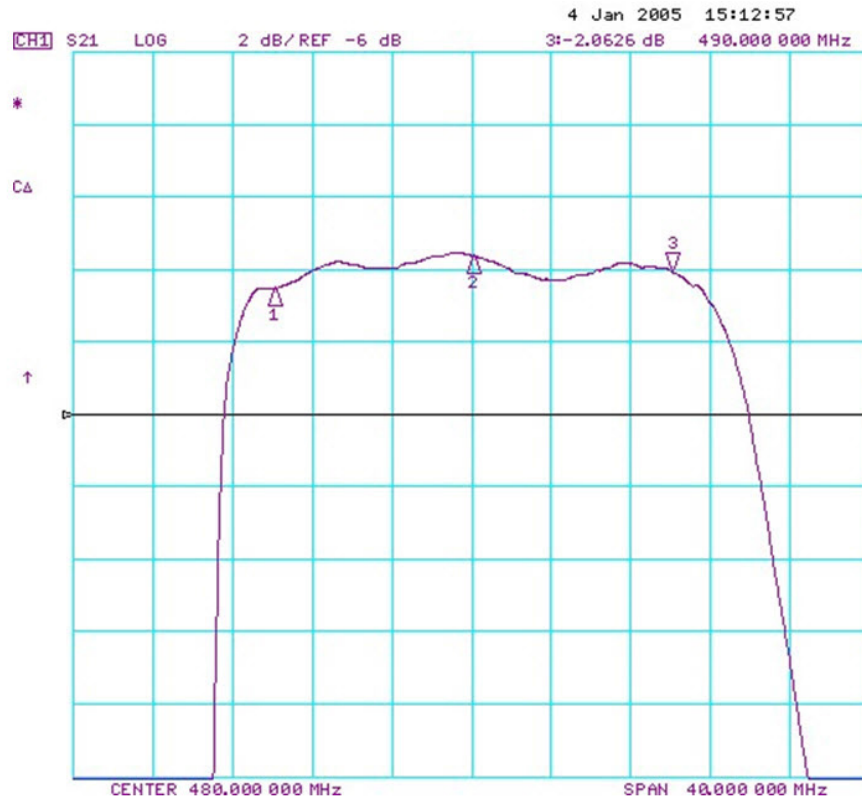

SM3838-8 Case

8-Terminal Ceramic Surface-Mount Case

3.8 X 3.8 mm Nominal Footprint

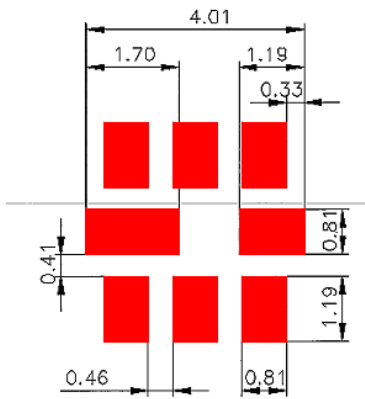
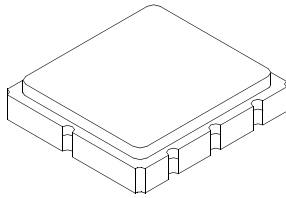

PCB Footprint

Case Dimensions						
Dimension	mm			Inches		
	Min	Nom	Max	Min	Nom	Max
A	3.6	3.8	4.0	0.142	0.150	0.157
B	3.6	3.8	4.0	0.142	0.150	0.157
C	1.05	1.20	1.35	0.041	0.047	0.053
D	0.95	1.10	1.25	0.037	0.043	0.049
E	0.90	1.00	1.10	0.035	0.040	0.043
F	0.50	0.60	0.70	0.020	0.024	0.028
G	2.39	2.54	2.69	0.090	0.100	0.110
H	1.40	1.75	2.05	0.055	0.069	0.080
I	0.90	1.00	1.10	0.035	0.040	0.043

Electrical Connections		
	Connection	Terminals
Port 1	Input	2
Port 2	Output	6
	Ground	All Others

Dot Indicates Pin 1

Materials	
Solder Pad Termination	Au plating 30 - 60 μ Inches (76.2-152 μ M) over 80-200 μ Inches (203-508 μ M) Ni.
Lid	Fe-Ni-Co Alloy Electroless Nickel Plate (8-11% Phosphorus) 100-200 μ Inches Thick
Body	Al ₂ O ₃ Ceramic
Pb Free	

TOP VIEW

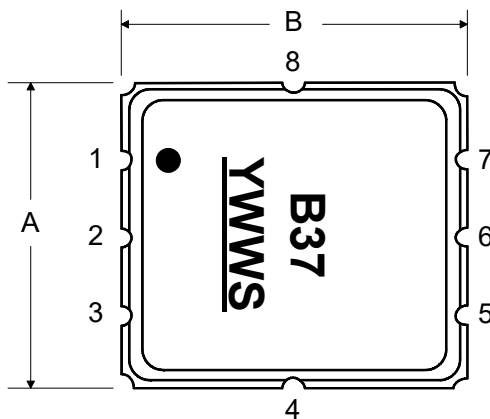

BOTTOM VIEW

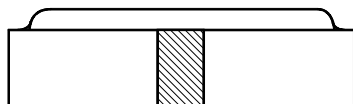
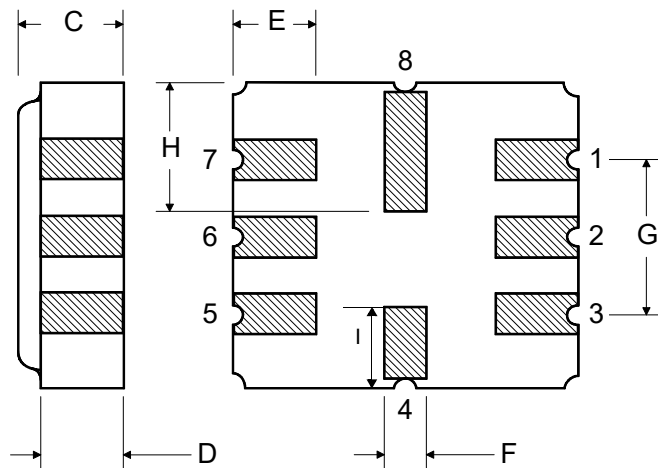

Tape and Reel Specifications

Tape and Reel Standard per ANSI/EIA-481

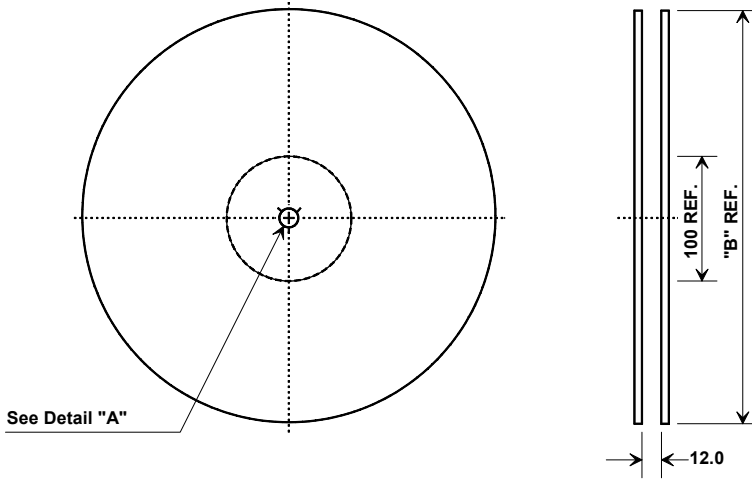

"B" Nominal Size		Quantity Per Reel
Inches	millimeters	
7	178	500
13	330	3000

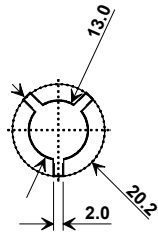

COMPONENT ORIENTATION and DIMENSIONS

Carrier Tape Dimensions	
Ao	4.25 mm
Bo	4.25 mm
Ko	1.30 mm
Pitch	8.0 mm
W	12.0 mm

