

GLASS PASSIVATED SUPER FAST RECTIFIER
VOLTAGE RANGE 50 to 600 Volts CURRENT 30 Ampere

FEATURES

- * Low switching noise
- * Low forward voltage drop
- * Low thermal resistance
- * High current capability
- * Super fast switching speed
- * High-reliability
- * Good for switching mode circuit

MECHANICAL DATA

- * Case: TO-220 molded plastic
- * Epoxy: Device has UL flammability classification 94V-0
- * Lead: MIL-STD-202E method 208C guaranteed
- * Mounting position: Any

MAXIMUM RATINGS AND ELECTRICAL CHARACTERISTICS

Ratings at 25°C ambient temperature.

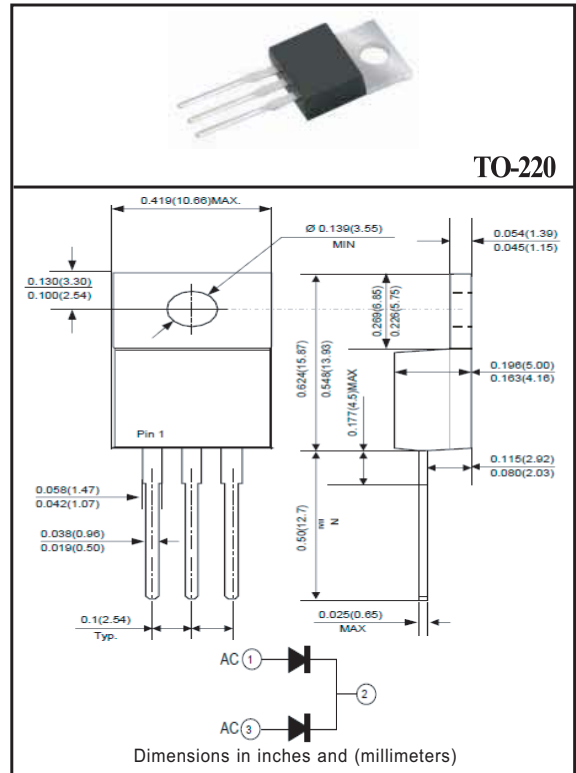

MAXIMUM RATINGS (At TA = 25°C unless otherwise noted)

| RATINGS | SYMBOL | SF301C | SF302C | SF303C | SF304C | SF305C | SF306C | SF307C | UNITS |
|---|------------------|--------------|--------|--------|--------|--------|--------|--------|---------------------|
| Maximum Recurrent Peak Reverse Voltage | VRRM | 50 | 100 | 150 | 200 | 300 | 400 | 600 | Volts |
| Maximum RMS Voltage | VRMS | 35 | 70 | 105 | 140 | 210 | 280 | 420 | Volts |
| Maximum DC Blocking Voltage | VDC | 50 | 100 | 150 | 200 | 300 | 400 | 600 | Volts |
| Maximum Average Forward Rectified Current at Tc = 100°C | IO | 30.0 | | | | | | | Amps |
| Peak Forward Surge Current 8.3 ms single half sine-wave superimposed on rated load (JEDEC method) | IFSM | 300 | | | | | | | Amps |
| Current Squared Time | I ² t | 373.5 | | | | | | | A ² /Sec |
| Typical Thermal Resistance | RθJC | 3 | | | | | | | °C/W |
| Typical Junction Capacitance (Note 2) | CJ | 120 | | | | | 100 | | pF |
| Operating and Storage Temperature Range | TJ, TSTG | -55 to + 150 | | | | | | | °C |

ELECTRICAL CHARACTERISTICS(At TA = 25°C unless otherwise noted)

| CHARACTERISTICS | SYMBOL | SF301C | SF302C | SF303C | SF304C | SF305C | SF306C | SF307C | UNITS |
|---|-------------|--------|--------|--------|--------|--------|--------|--------|-------|
| Maximum Instantaneous Forward Voltage at 15.0A DC | VF | 1.0 | | | | 1.35 | | 1.70 | Volts |
| Maximum DC Reverse Current at Rated DC Blocking Voltage | @Tc = 25°C | 10 | | | | | | | uAmps |
| | @Tc = 100°C | | | | | | | | |
| Maximum Reverse Recovery Time (Note 1) | trr | 35 | | | | 50 | | nSec | |

- NOTES : 1. Test Conditions: IF = 0.5A, IR = -1.0A, IRR = -0.25A
 2. Measured at 1 MHz and applied reverse voltage of 4.0 volts.
 3. Suffix "A" =Common Anode.
 4. "Fully ROHS compliant", "100% Sn plating (Pb-free)".

RATING AND CHARACTERISTIC CURVES (SF301C THRU SF307C)

FIG. 1 - TYPICAL FORWARD CURRENT DERATING CURVE

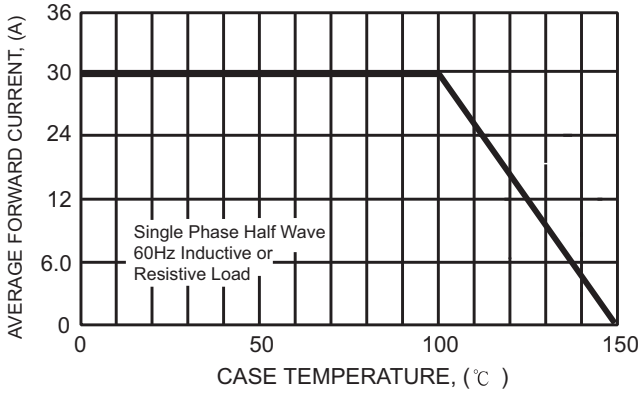

FIG. 2 - TYPICAL REVERSE CHARACTERISTICS

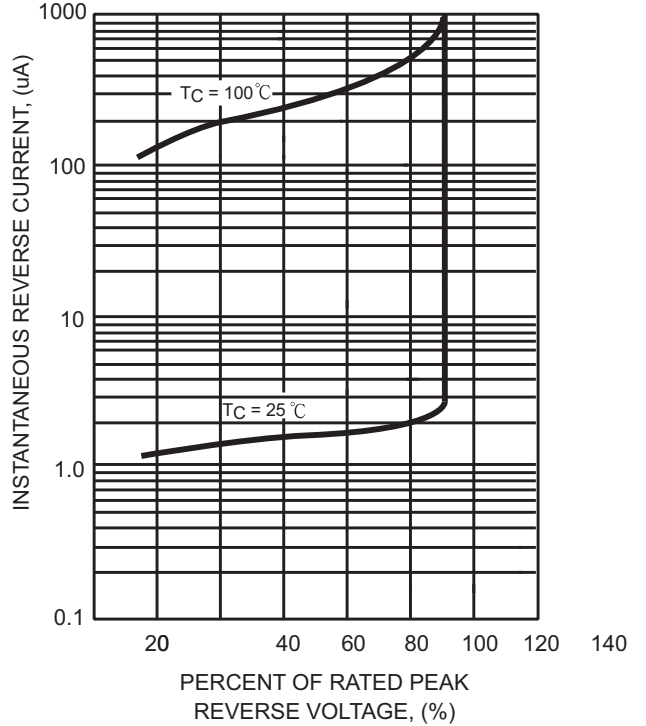

FIG. 3 - MAXIMUM NON-REPETITIVE FORWARD SURGE CURRENT

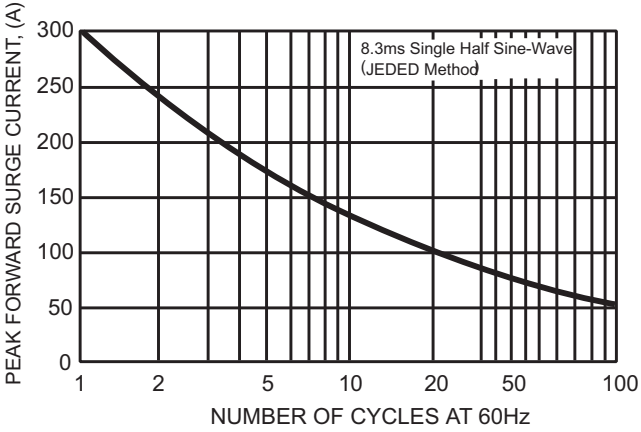

FIG. 4 - TYPICAL INSTANTANEOUS FORWARD CHARACTERISTICS

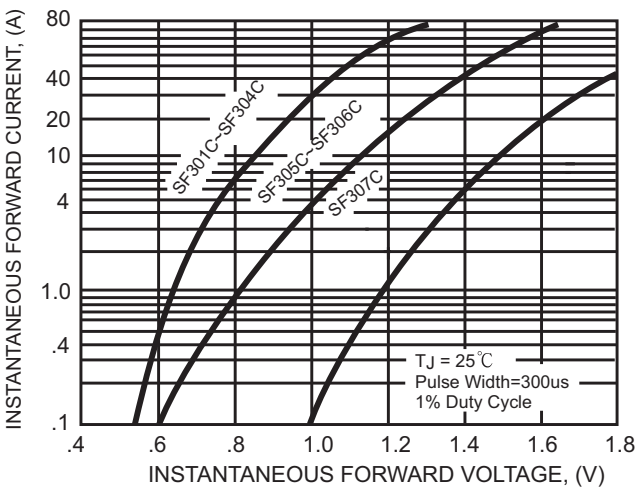
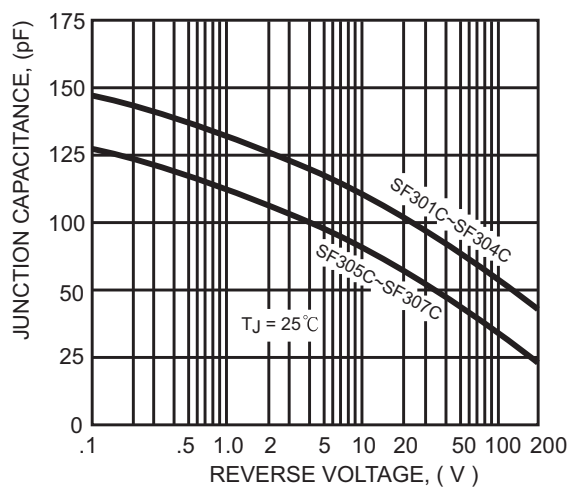
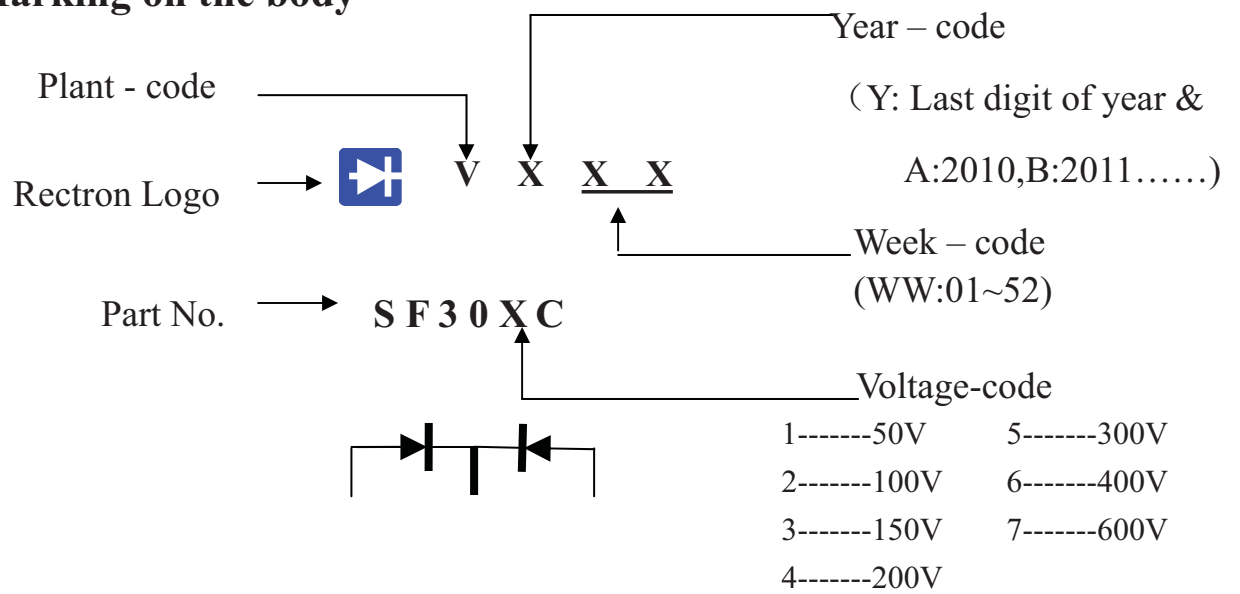

FIG. 5 - TYPICAL JUNCTION CAPACITANCE



2. Marking on the body



PACKAGING OF DIODE AND BRIDGE RECTIFIERS

TUBE PACK

| PACKAGE | PACKING CODE | EA PER BOX | INNER BOX SIZE (mm) | CARTON SIZE (mm) | EA PER CARTON | WEIGHT(Kg) |
|---------|--------------|------------|------------------------|---------------------|---------------|------------|
| TO-220 | -C | 1,000 | 555*150*40 | 580*230*175 | 5,000 | 15.0 |