

GLASS PASSIVATED SUPER FAST RECTIFIER
VOLTAGE RANGE 50 to 600 Volts CURRENT 30 Ampere

FEATURES

- * Low switching noise
- * Low forward voltage drop
- * Low thermal resistance
- * High current capability
- * Super fast switching speed
- * High-reliability
- * Good for switching mode circuit

MECHANICAL DATA

- * Case: TO-220 molded plastic
- * Epoxy: Device has UL flammability classification 94V-0
- * Lead: MIL-STD-202E method 208C guaranteed
- * Mounting position: Any

MAXIMUM RATINGS AND ELECTRICAL CHARACTERISTICS

Ratings at 25°C ambient temperature.

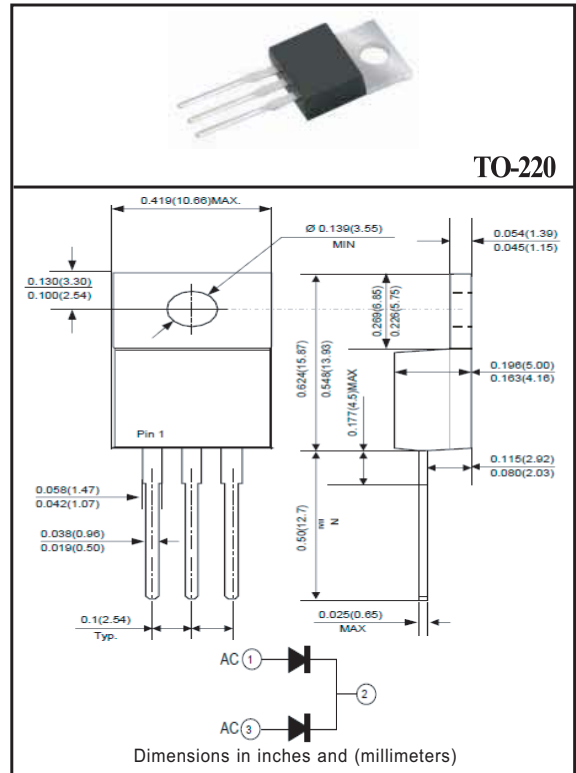

MAXIMUM RATINGS (At TA = 25°C unless otherwise noted)

RATINGS	SYMBOL	SF301C	SF302C	SF303C	SF304C	SF305C	SF306C	SF307C	UNITS
Maximum Recurrent Peak Reverse Voltage	VRRM	50	100	150	200	300	400	600	Volts
Maximum RMS Voltage	VRMS	35	70	105	140	210	280	420	Volts
Maximum DC Blocking Voltage	VDC	50	100	150	200	300	400	600	Volts
Maximum Average Forward Rectified Current at Tc = 100°C	IO	30.0							Amps
Peak Forward Surge Current 8.3 ms single half sine-wave superimposed on rated load (JEDEC method)	IFSM	300							Amps
Current Squared Time	I ² t	373.5							A ² /Sec
Typical Thermal Resistance	RθJC	3							°C/W
Typical Junction Capacitance (Note 2)	CJ	120					100		pF
Operating and Storage Temperature Range	TJ, TSTG	-55 to + 150							°C

ELECTRICAL CHARACTERISTICS(At TA = 25°C unless otherwise noted)

CHARACTERISTICS	SYMBOL	SF301C	SF302C	SF303C	SF304C	SF305C	SF306C	SF307C	UNITS
Maximum Instantaneous Forward Voltage at 15.0A DC	VF	1.0				1.35		1.70	Volts
Maximum DC Reverse Current at Rated DC Blocking Voltage	@Tc = 25°C	10							uAmps
	@Tc = 100°C								
Maximum Reverse Recovery Time (Note 1)	trr	35				50		nSec	

- NOTES : 1. Test Conditions: IF = 0.5A, IR = -1.0A, IRR = -0.25A
 2. Measured at 1 MHz and applied reverse voltage of 4.0 volts.
 3. Suffix "A" =Common Anode.
 4. "Fully ROHS compliant", "100% Sn plating (Pb-free)".

RATING AND CHARACTERISTIC CURVES (SF301C THRU SF307C)

FIG. 1 - TYPICAL FORWARD CURRENT DERATING CURVE

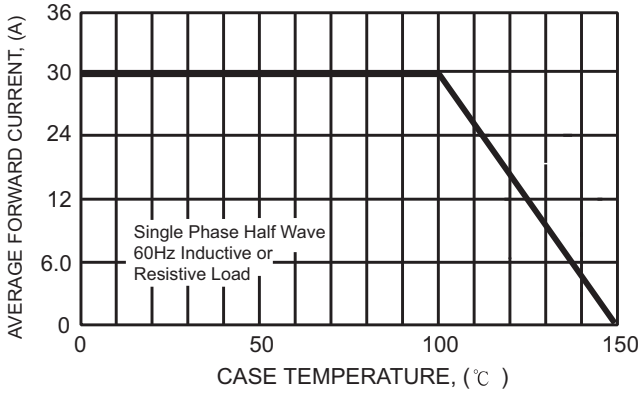

FIG. 2 - TYPICAL REVERSE CHARACTERISTICS

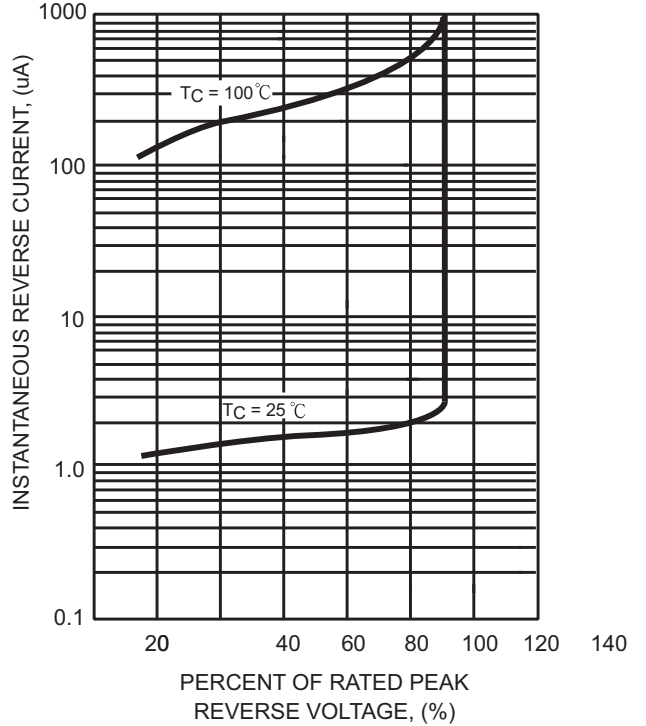

FIG. 3 - MAXIMUM NON-REPETITIVE FORWARD SURGE CURRENT

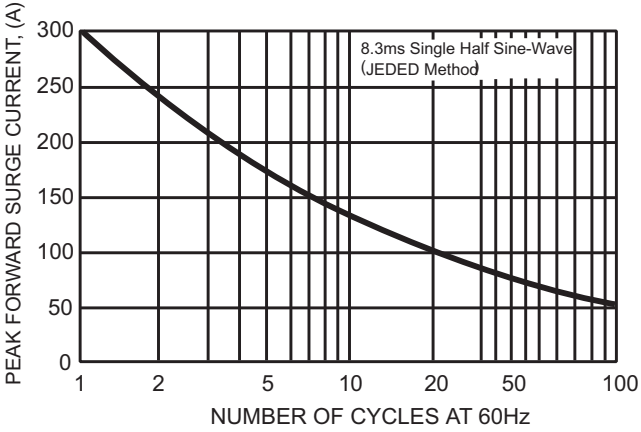

FIG. 4 - TYPICAL INSTANTANEOUS FORWARD CHARACTERISTICS

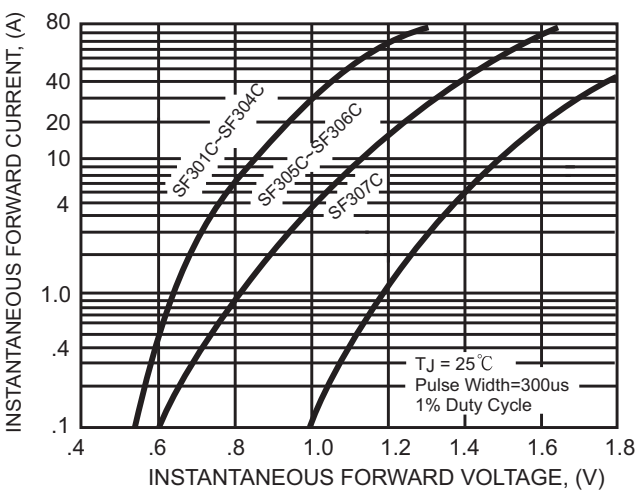
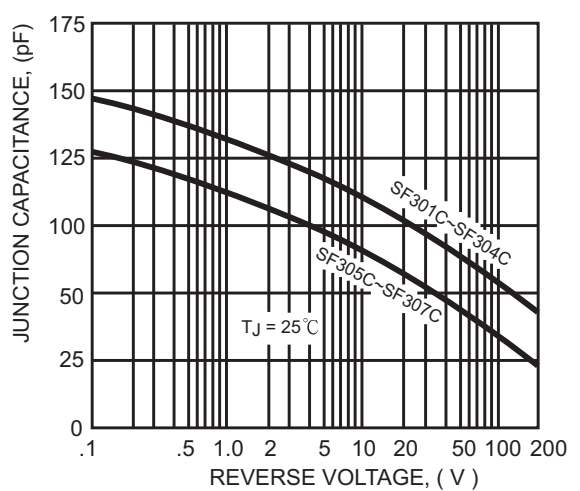
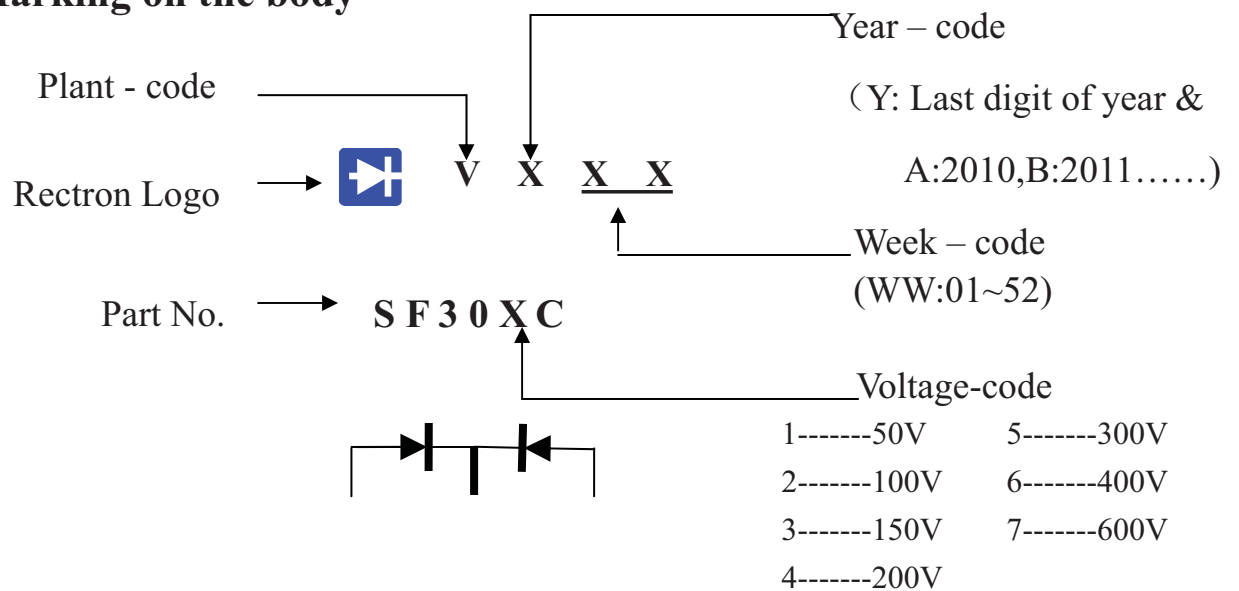

FIG. 5 - TYPICAL JUNCTION CAPACITANCE



2. Marking on the body



PACKAGING OF DIODE AND BRIDGE RECTIFIERS

TUBE PACK

PACKAGE	PACKING CODE	EA PER BOX	INNER BOX SIZE (mm)	CARTON SIZE (mm)	EA PER CARTON	WEIGHT(Kg)
TO-220	-C	1,000	555*150*40	580*230*175	5,000	15.0