

swissbit®

Product Data Sheet

Industrial microSDHC / SDXC Memory Card

S-56u High reliability series
UHS-I Interface, 3D pSLC-mode

Extended and Industrial
Temperature Grade

Date: August 28, 2020
Revision: 1.02



Contents

1. PRODUCT SUMMARY	3
2. PRODUCT FEATURES	3
3. ORDERING INFORMATION	5
4. PRODUCT DESCRIPTION	6
4.1 PERFORMANCE SPECIFICATIONS	6
4.2 ENVIRONMENTAL SPECIFICATIONS	6
4.3 PHYSICAL DIMENSIONS	7
4.4 RELIABILITY	8
4.5 ENDURANCE	8
5. USER DENSITY SPECIFICATION	8
6. CARD PHYSICAL	9
6.1 PHYSICAL DESCRIPTION	9
7. ELECTRICAL INTERFACE	10
7.1 ELECTRICAL DESCRIPTION	10
7.2 POWER UP / POWER DOWN BEHAVIOR AND RESET	11
7.3 DC CHARACTERISTICS	11
7.4 SIGNAL LOADING	12
7.5 AC CHARACTERISTICS	12
8. HOST ACCESS SPECIFICATION	13
8.1 SD AND SPI BUS MODES	13
8.2 CARD REGISTERS	14
9. PART NUMBER DECODER	19
10. MARKING SPECIFICATION	21
10.1 TOP VIEW	21
10.2 BACK SIDE MARKING	21
11. REVISION HISTORY	22

S-56u High reliability series

Industrial microSDHC / SDXC Memory Card

4 GBytes up to 32 GBytes

1. Product Summary

- **Capacities:** 4 GBytes, 8 GBytes, 16 GBytes, 32 GBytes
- **Form Factor:** Standard microSD Memory card form factor – 15.0mm x 11.0mm x 0.7mm (1.0mm)
- **Compliance¹:** Fully compliant with SD Memory Card specification 6.10
 - SDHC/SDXC high speed mode, UHS-I
 - Speed class 10/U3/V30/A2 according SD6.10 specification
 - SD2.0 backward compliant
 - FAT32 / exFAT preformatted
- **Environmental:** RoHS / REACH Compliant
- **Compatibility:** Support SD SPI mode
- **Performance (max. capacity):**
 - Read performance: sequential read up to 95 MBytes/s
 - Write performance: sequential write up to 80 MBytes/s
 - SDR12, SDR25, SDR50, SDR104, DDR50 mode
- **Operating Temperature Range:**
 - Extended: -25 °C to 85 °C
 - Industrial: -40 °C to 85 °C
- **Storage Temperature Range:** -40 °C to 85 °C
- **Operating Voltage:** 2.7...3.6V
- **Data Retention:** 10 years @ life begin; 1 year @ life end
- **Error Correction:** Advanced ECC (Error Correction Code)
 - Mean Time Between Failure (MTBF): > 2,000,000 hours
 - Number of insertions: up to 20,000

2. Product Features

- High performance 6.10 specification
 - SD burst up to 104MB/s
 - SD Normal speed 0...25MHz clock rate
 - SD High speed 25...50MHz clock rate
 - SD UHS-I speed 0...50MHz (DDR) and 0...208MHz (SDR)
- Power Supply: (Low-power CMOS technology)
 - 2.7...3.6V normal operating voltage
- Optimized FW algorithms especially for read/write access, highest random write performance and best endurance with long data retention.
 - Designed for usage in applications with highest requirements regarding reliability like data logging, POS/POI, Medical and other demanding use-cases.
 - Especially suitable for intensive read/write operations
 - Advanced power-off reliability technology
 - Wear Leveling technology
Equal wear leveling of static and dynamic data. The wear leveling assures that dynamic data as well as static data is balanced evenly across the memory. With that the maximum write endurance of the device is guaranteed

¹ The verification of host system and storage device compatibility is in customer's responsibility. Swissbit can provide guidance and support on request.

- The S-56u high reliability series is optimized for high read/write traffic for demanding industrial applications. The series is especially developed for high random write performance and best endurance.
- Read Disturb Management
The read commands are monitored and the content is refreshed when critical levels have occurred
- Data Care Management
The interruptible background process maintain the user data for Read Disturb effects or Retention degradation due to high temperature effects
- Near miss ECC technology
Minimize the risk of uncorrectable bit failure over the product life time. Each read command analyzes the ECC margin level and refresh data if necessary
- Diagnostic features with Life Time Monitoring tool support
- High reliability
 - The product is optimized for long life cycle that requires superior data retention because of high temperature mission profile
 - FW is designed to ensure highest reliability at lowest possible DPPM rates
 - Number of card insertions/removals up to 20,000
 - Industrial Temperature range -40° up to 85°C inclusive full cross temperature support²
 - SIP (System In Package) process for extreme dust, water and ESD proof
- Controlled "Locked" BOM & PCN process
- Customized options like CID registers, CPRM keys, firmware incl. settings and marking on request
- Manufactured in a TS 16949 certified factory
- In-field firmware update³
- Swissbit Life Time Monitoring (SBLTM) Tool and SDK for SBLTM (on request)



² Cross temp. stability of 125 Kelvin: Feasible temperature difference between write/read of same data, e.g. write @ -40°C , read @ 85°C .
³ The support of In-Field FW update capabilities on host systems is recommended.

3. Ordering Information

Table 1: Standard Product List

Capacity	Temperature	
	Extended	Industrial
	Part Number	Part Number
4 GBytes	SFSD004GNgAM1T0-E-xx-2yP-STD	SFSD004GNgAM1T0-I-xx-2yP-STD
8 GBytes	SFSD008GNgAM1T0-E-xx-2yP-STD	SFSD008GNgAM1T0-I-xx-2yP-STD
16 GBytes	SFSD016GNgAM1T0-E-xx-2yP-STD	SFSD016GNgAM1T0-I-xx-2yP-STD
32 GBytes	SFSD032GNgAM1T0-E-xx-2yP-STD	SFSD032GNgAM1T0-I-xx-2yP-STD

g = product generation, xx = flash configuration, y = firmware revision

Table 2: Available Part Numbers

Capacity	Temperature	
	Extended	Industrial
	Part Number	Part Number
4 GBytes	SFSD004GN1AM1T0-E-5E-21P-STD	SFSD004GN1AM1T0-I-5E-21P-STD
8 GBytes	SFSD008GN1AM1T0-E-5E-21P-STD	SFSD008GN1AM1T0-I-5E-21P-STD
16 GBytes	SFSD016GN1AM1T0-E-ZK-21P-STD	SFSD016GN1AM1T0-I-ZK-21P-STD
32 GBytes	SFSD032GN1AM1T0-E-ZK-21P-STD	SFSD032GN1AM1T0-I-ZK-21P-STD

4. Product Description

The microSD Memory Card is a small form factor non-volatile memory card that provides high capacity data storage. Its aim is to capture, retain and transport data, audio and images, facilitating the transfer of all types of digital information between a large variety of digital systems.

The card operates in two basic modes:

- SDHC/SDXC and UHS-I card modes
- SPI mode

The microSD Memory Card also supports SD Default and High Speed mode with up to 50MHz clock frequency as well as UHS-I modes DDR50, SDR12/25/50/104 with up to 208MHz clock frequency.

- SD Memory card Specification Part 1, Physical layer Specification V6.10
- SD Memory card Specification Part 2, File System Specification V3.00
- microSD Card Addendum Ver4.20

Simplified specifications are available at <https://www.sdcard.org/>

The Card has an internal intelligent controller that manages interface protocols, data storage and retrieval as well as hardware LDPC Error Correction Code (ECC), defect handling, diagnostics and clock control. The advanced wear leveling mechanism assures an equal usage of the Flash memory cells to extend the lifetime.

The hardware LDPC-code ECC allows to detect and correct up to 120 defect bits per 1kByte.

The card has a power-loss management feature to prevent data corruption after power-down.

The cards are RoHS compliant and lead-free.

4.1 Performance Specifications

The S-56u read/write sequential and random CDM performance benchmarks are detailed in Table 3.

Table 3: Read/Write Performance

System Performance	typ ⁴ 5				Unit
	4GB	8GB	16GB	32GB	
Sequential Read	95	95	95	95	MB/s
Sequential Write	25	74	78	83	
Random Read 4k	2190	2190	2190	2180	IOPS
Random Write 4k	1150	1250	1320	1360	

4.2 Environmental Specifications

4.2.1 Recommended operating conditions

Table 4: microSD Memory Card recommended operating conditions

Parameter	min	typ	max	unit
Extended Operating Temperature	-25	25	85	°C
Industrial Operating Temperature	-40	25	85	°C

⁴ All values refer to Toshiba / Kioxia Flash 128Gb/256Gb 3D TLC

⁵ Card Speed measured with USB-SD Memory Card reader with Crystal Disk Mark 5.1.2 test tool 5x 1GB.

4.2.2 Recommended storage conditions

Table 5: microSD Memory Card recommended storage conditions⁶

Parameter	min	typ	max ⁷	unit
Extended Storage Temperature	-25	25	100	°C
Industrial Storage Temperature	-40	25	100	°C

4.2.3 Humidity & EMC

Table 6: Humidity & EMC

Parameter	Condition
Humidity (non-condensing)	85% RH @85°C 1000h
ESD	<p>up to ±4 kV (contact discharge), according to IEC61000-4-2 and SDA, Human Body Model 150pF/ 330Ωhm, on each contact pad, non-operating</p> <p>up to ±15 kV, (air discharge), according to IEC61000-4-2 and SDA, Human Body Model 150pF/ 330Ωhm, isolated contact pad area, non-operating</p>

4.2.4 Environmental conditions

Table 7: Environmental conditions

Parameter	Condition
UV light exposure	UV: 254nm, 15Ws/cm ² according to ISO7816-1
X-Ray	0.1 Gy 70keV to 140KeV (ISO7816-1) according SDA
Durability	20,000 mating cycles
Drop Test	1.5m free fall
Bending / Torque	10N / 0.15Nm ±2.5° max
Mechanical Shock	1500G, 0.5ms, half sine wave ±xyz-axis, 4 pulses each non-operating, JESD22B110/B104 Condition B
Vibration	Non-operating, JESD22B110/B104 Condition B

4.3 Physical dimensions

Table 8: Physical dimensions

Outer Physical dimensions	Value	Unit
Length	15.00±0.1	mm
Width	11.00±0.1	
Thickness	0.7 (1.)±0.1	
Weight (typ.)	0.4	g

⁶ The data retention time at temperature above 40°C is reduced. Swissbit can provide more data and support on request.

⁷ High Temperature storage without operation reduces the data retention, in operation the data will be refreshed, if data error issues were detected

4.4 Reliability

Data reliability with data retention at the beginning and end of life is provided in the table below.

Table 9: Reliability⁸

Parameter	Value ⁹
Data Retention at beginning @ 40°C (JESD47)	10 years
Data Retention at life end @ 40°C	1 year

4.5 Endurance

Endurance represented as TeraBytes Written (TBW) is provided in the following Table 10:

Table 10: Endurance^{10 11}

Drive Capacity	TeraBytes Written (TBW) @ Seq. Write 1MB Operation	TeraBytes Written (TBW) @ Random Write 128kB Operation	TeraBytes Written (TBW) @ Random Write 4kB Operation
4 GBytes	166	15.1	1.8
8 GBytes	349	14.6	1.6
16 GBytes	515	20.6	2.6
32 GBytes	1028	21.6	2.0

5. User density specification

Table 11: microSD Memory Card capacity specification

Capacity	Sectors	Total addressable Bytes
4 GBytes	7,774,208	3,980,394,496
8 GBytes	15,802,368	8,090,812,416
16 GBytes	30,318,592	15,523,119,104
32 GBytes	60,637,184	31,046,238,208

⁸ NAND Flash data retention and endurance characteristics are defined according to JEDEC JESD47 and JESD22. The endurance limits of the storage shall be monitored by the life time information and simulated before field usage by the customer.

⁹ After every power on the card reads the whole flash and performs a data refresh if necessary. Therefore, the data retention can be much longer in most use cases.

¹⁰ The specified TBW is valid, if the amount of data is spread evenly over at least 24 months. Higher daily data volume or frequent writing below 0°C reduces the specified TBW. The drive endurance limit, also called EOL or 0% remaining life, is defined as TBW or DWPD over the product's limited lifetime warranty period. TBW calculations refer to the JEDEC JESD218A and JESD219A standard for SSD device life and endurance measurement techniques if not otherwise specified.

¹¹ Sequential write 1MB simulates a continuous stream recording on a drive which has been preconditioned with a sequential write of the complete drive, Random Write 128KB or 4KB represent data logging applications with large or small block sizes.

6. Card physical

6.1 Physical description

The microSD Memory Card contains a single chip controller and Flash memory module(s). The controller interfaces with a host system allowing data to be written to and read from the Flash memory module(s).

Figure 1: Simplified mechanical dimensions microSD Memory Card

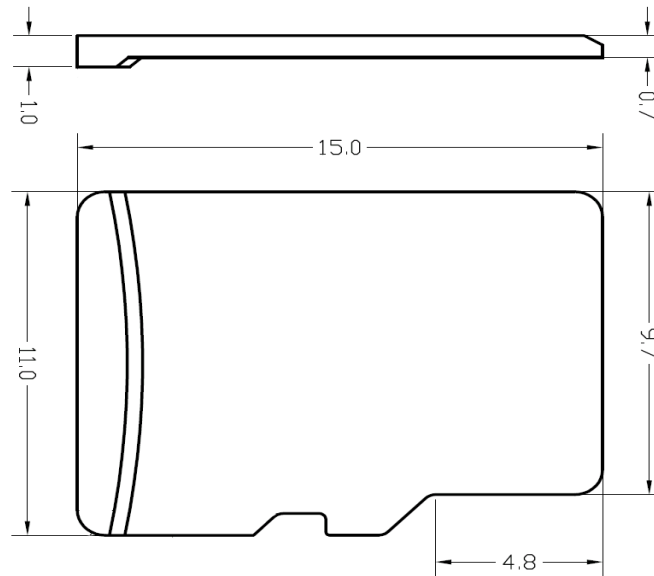

The dimensions and tolerances are according to the SD specification.

7. Electrical interface

7.1 Electrical description

Figure 2: microSD Memory Card shape and Interface (bottom view)

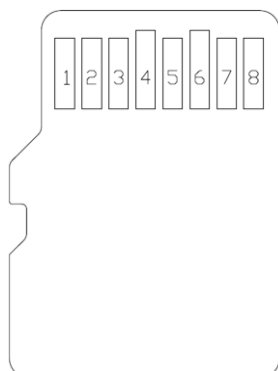

Table 12: Pad Assignment – SD Mode

Pin	SD Mode		
	Name	Type ¹²	Description
1	DAT ₂ ¹³	I/O/PP	Data Line [Bit 2]
2	CD/DAT ₃ ¹⁴	I/O/PP ¹⁵	Card Detect/ Data Line [Bit 3]
3	CMD	PP	Command/Response
4	VDD	S	Supply voltage
5	CLK	I	Clock
6	VSS	S	Supply voltage ground
7	DAT ₀	I/O/PP	Data Line [Bit 0]
8	DAT ₁ ¹⁶	I/O/PP	Data Line [Bit 1]

¹² S: power supply; I: input; O: output using push-pull drivers; PP: I/O using push-pull drivers

¹³ DAT₂ line may be used as Read Wait signal in SDIO mode (refer to "SDIO Card Specification" for further details).

¹⁴ The extended DAT lines (DAT₁-DAT₃) are input on power up. They start to operate as DAT lines after SET_BUS_WIDTH command. The Host shall keep its own DAT₁-DAT₃ lines in input mode, as well, while they are not used.

¹⁵ At power up this line has a 50kOhm pull up enabled in the card. This resistor serves two functions Card detection and Mode Selection. For Mode Selection, the host can drive the line high or let it be pulled high to select SD mode.

If the host wants to select SPI mode it should drive the line low. For Card detection, the host detects that the line is pulled high. The host should disconnect this pull-up during regular data transfer, with SET_CLR_CARD_DETECT (ACMD42) command.

¹⁶ DAT₁ line may be used as Interrupt Output (from the Card) in SDIO mode during all the times that it is not in use for data transfer operations (refer to "SDIO Card Specification" for further details).

Table 13: Pad Assignment – SPI Mode

Pin	SPI Mode		
	Name	Type ¹²	Description
1	RSV		
2	CS	I ¹⁵	Chip Select (neg true)
3	DI	I	Data In
4	VDD	S	Supply voltage
5	SCLK	I	Clock
6	VSS	S	Supply voltage ground
7	DO	O/PP	Data Out
8	RSV		

7.2 Power up / Power down behavior and reset

7.2.1 Power up

The host can start with communication 1ms after 2.7V is reached according the SDA specification. That should perform 74 clock cycles and start with the sequence CMD0, CMD8, ACMD41 until card is ready as described in the SD specification 6.10.

7.2.2 Power down

When the power falls below 2.6V the controller stops the communication to the flash, but enables the flash to finish a started flash program operation (if voltage drop is not fast).

7.2.3 Power drop

If the voltage drops below 2.6V and rises again, the card performs a reset. The card must be initialized like after a power on.

7.3 DC characteristics

Measurements are not recommended operation conditions unless otherwise specified.

Table 14: DC characteristics

Symbol	Parameter	Density	Min	Typ	Max	Unit	Notes
I _{DD}	Operating Current Read (UHS-I / HS)	4GB		145 / 45	160	mA	@ 25°C
		8/16/32		140 / 50	160	mA	@ 25°C
I _{DD}	Operating Current Write (UHS-I / HS)	4GB		90 / 50	120	mA	@ 25°C
		8/16/32		90 / 50	120	mA	@ 25°C
I _{DD}	Standby Current			2		mA	@ 25°C
I _{DD}	Autoread Current (UHS-I / HS) during standby			65 / 40	110	mA	@ 25°C
I _{LI}	Input Leakage Current		-2		2	µA	without pull up R
I _{LO}	Output Leakage Current		-2		2	µA	without pull up R

Table 15: microSD Memory Card recommended operation conditions

Symbol	Parameter		Min	Typ	Max	Unit
V _{DD}	Supply voltage	Normal operating status	2.7	3.3	3.6	V
-	Power Up Time (from 0V to VDD min)				250	ms

7.4 Signal loading

According to SD specification

7.5 AC characteristics

7.5.1 Default speed mode (0-25MHz)

According to SD specification

7.5.2 High speed mode (0-50MHz)

According to SD specification

7.5.3 UHS modes

UHS modes were driven with a signal level of 1.8V.

The cards support following UHS-I modes:

Table 16: Supported UHS-I modes

Mode	Max. Burst MB/s	Max. Clock frequency MHz
SDR12	12.5	25
SDR25	25	50
SDR50	50	100
SDR104	104	208
DDR50	50	50 (rising and falling edge)

According to the SD specification

8. Host access specification

The following chapters summarize how the host accesses the card:

- Chapter 8.1 summarizes the SD and SPI buses.
- Chapter 8.2 summarizes the registers.

8.1 SD and SPI Bus Modes

The card supports SD and the SPI Bus modes. Application can chose either one of the modes. Mode selection is transparent to the host. The card automatically detects the mode of the reset command and will expect all further communication to be in the same communication mode. The SD mode uses a 4-bit high performance data transfer, and the SPI mode provides compatible interface to MMC host systems with little redesign, but with a lower performance.

8.1.1 SD Bus Mode Protocol

The SD Bus mode has a single master (host) and multiple slaves (cards) synchronous topology. Clock, power, and ground signals are common to all cards. After power up, the SD Bus mode uses DAT0 only; after initialization, the host can change the cards' bus width from 1 bit (DAT0) to 4 bits (DAT0-DAT3). In high speed mode, only one card can be connected to the bus.

Communication over the SD bus is based on command and data bit streams which are initiated by a start bit and terminated by a stop bit.

- **Command:** a command is a token which starts an operation. A command is sent from the host either to a single card (addressed command) or to all connected cards (broadcast command). A command is transferred serially on the CMD line.
- **Response:** a response is a token which is sent from an addressed card, or (synchronously) from all connected cards, to the host as an answer to a previously received command. A response is transferred serially on the CMD line.
- **Data:** data can be transferred from the card to the host or vice versa. Data is transferred via the data lines.

8.1.2 SPI Bus Mode Protocol

The Serial Peripheral Interface (SPI) Bus is a general purpose synchronous serial interface. The SPI mode consists of a secondary communication protocol. The interface is selected during the first reset command after power up (CMD0) and it cannot be changed once the card is powered on.

While the SD channel is based on command and data bit streams which are initiated by a start bit and terminated by a stop bit, the SPI channel is byte oriented. Every command or data block is built of 8-bit bytes and is byte aligned to the CS signal.

The card identification and addressing methods are replaced by a hardware Chip Select (CS) signal. There are no broadcast commands. For every command, a card (slave) is selected by asserting (active low) the CS signal. The CS signal must be continuously active for the duration of the SPI transaction (command, response and data). The only exception occurs during card programming, when the host can de-assert the CS signal without affecting the programming process.

The bidirectional CMD and DAT lines are replaced by unidirectional dataIn and dataOut signals.

Table 17: SPI Bus signals

Signal	Description
/CS	Host to card chip select
CLK	Host to card clock signal
Data In	Host to card data signal
Data Out	Card to host data signal
Vdd, Vss	Power and ground

8.1.3 Mode Selection

The microSD Memory Card wakes up in the SD mode. It will enter SPI mode if the CS signal is asserted (negative) during the reception of the reset command (CMD0) and the card is in idle_state. If the card recognizes that the SD mode is required it will not respond to the command and remain in the SD mode.

If SPI mode is required the card will switch to SPI and respond with the SPI mode R1 response.

The only way to return to the SD mode is by entering the power cycle. In SPI mode the microSD Memory Card protocol state machine is not observed. All the microSD Memory Card commands supported in SPI mode are always available.

During the initialization sequence, if the host gets Illegal Command indication for ACMD41 sent to the card, it may assume that the card is Multimedia Card. In that case it should restart the card as Multimedia Card using CMD0 and CMD1.

8.2 Card Registers

The microSD Memory Card has the following registers.

Table 18: microSD Memory Card registers

Register name	Bit width	Description	Function
CID	128	Card Identification information	This register contains the card identification information used during the Card Identification phase.
OCR	32	Operation Conditions Registers	This register describes the operating voltage range and contains the status bit in the power supply.
CSD	128	Card specific information	This register provides information on how to access the card content. Some fields of this register are writable by PROGRAM_CSD (CMD27).
SCR	64	microSD Memory Card's Special features	This register provides information on special features.
RCA ¹⁷	16	Relative Card Address	This register carries the card address in SD Card mode.
SSR	512	SD Status	information about the card proprietary features and vendor specific life time information

Table 19: CID register

Register name	Bit width	Description	Function
MID	8	Manufacture ID	0x5d
OID	16	OEM/Application ID	0x5342
PNM	40	Product Name	e.g. "0064G"
PRV	8	Product Revision	0xgg
PSN	32	Product Serial Number	xxxxxxxx
—	4	Reserved	0x0
MDT	12	Manufacture Date	oxyym
CRC	7	Check sum of CID contents	chksum
—	1	Not used; always=1	1

¹⁷ RCA register is not available in SPI mode

Table 20: OCR register

OCR bit position	VDD voltage windows	Typ. value	OCR bit position	VDD voltage window	Typ. value
0-3	Reserved	0	15	2.7-2.8	1
4	1.6-1.7	0	16	2.8-2.9	1
5	1.7-1.8	0	17	2.9-3.0	1
6	1.8-1.9	0	18	3.0-3.1	1
7	1.9-2.0	0	19	3.1-3.2	1
8	2.0-2.1	0	20	3.2-3.3	1
9	2.1-2.2	0	21	3.3-3.4	1
10	2.2-2.3	0	22	3.4-3.5	1
11	2.3-2.4	0	23	3.5-3.6	1
12	2.4-2.5	0	24	Switching to 1.8V accepted	1
13	2.5-2.6	0	25-29	Reserved	
14	2.6-2.7	0	30	Card Capacity Status (CCS)	*18
			31	0=busy; 1=ready	*19

Table 21: CSD register

Register name	Bits	Bit width	Description	Typ. value
CSD_STRUCTURE	127:126	2	CSD structure	01
–	125:120	6	Reserved	00000
TAAC	119:112	8	Data read access time 1	00001110
NSAC	111:104	8	Data read access time 2 (CLK cycle)	00000000
TRAN_SPEED	103:96	8	Data transfer rate	00110010 Default speed 00101011 SDR 104 or other values
CCC	95:84	12	Card command classes	010110110101
READ_BLK_LEN	83:80	4	Read data block length	1001
READ_BLK_PARTIAL	79	1	Partial blocks for read allowed	0
WRITE_BLK_MISALIGN	78	1	Write block misalignment	0
READ_BLK_MISALIGN	77	1	Read block misalignment	0
DSR_IMP	76	1	DSR implemented	0
–	75:70	6	Reserved	000000
C_SIZE	69:48	22	Device size	xxx ²⁰
–	47	1	Reserved	0
ERASE_BLK_EN	46	1	Erase single block enable	1
SECTOR_SIZE	45:39	7	Erase sector size	1111111
WP_GRP_SIZE	38:32	7	Write protect group size	0000000
WP_GRP_ENABLE	31	1	Write protect group enable	0
–	30:29	2	Reserved	00
R2W_FACTOR	28:26	3	Write speed factor	010

¹⁸ This bit is valid only when the card power up status bit is set

¹⁹ This bit is set to LOW if the card has not finished the power up routine

²⁰ Drive size and block sizes vary with card capacity

WRITE_BL_LEN	25:22	4	Write data block length	1001 ²⁰
WRITE_BL_PARTIAL	21	1	Partial blocks for write allowed	0
–	20:16	5	Reserved	00000
FILE_FORMAT_GRP	15	1	File format group	0 W(1)
COPY	14	1	Copy flag	0 W(1)
PERM_WRITE_PROTECT	13	1	Permanent write protection	0 W(1)
TMP_WRITE_PROTECT	12	1	Temporary write protection	0 W
FILE_FORMAT	11:10	2	File format	00 W(1)
–	9:8	2	Reserved	00 W
CRC	7:1	7	Checksum of CSD contents	xxxxxxx
–	0	1	Always=1	1

Memory capacity = (C_SIZE+1) * 512kByte

W value can be changed with CMD27 (PROGRAM_CSD)
W(1) value can be changed ONCE with CMD27 (PROGRAM_CSD)

Table 22: SCR register

Field	Bits	Bit width	Typ. value	Remark
SCR_STRUCTURE	63:60	4	0000	SCR 1.0
SD_SPEC	59:56	4	0010	SD 2.0 or higher
DATA_STAT_AFTER_ERASE	55	1	0	data are 0xFF after erase
SD_SECURITY	54:52	3	000	No security
SD_BUS_WIDTHS	51:48	4	0101	1 or 4 bit
SD_SPEC3	47	1	1	yes
EX_SECURITY	46:43	4	0000	no extended security
SD_SPEC4	42:42	1	1	yes
SD_SPECX	41:38	4	2	Version 6.xx
Reserved	37:36	9	0	
CMD_SUPPORT	35:32	2	11	CMD23 and CMD20 supported
Reserved	31:0	32	0	

Table 23: RCA register

Field	Bits	Bit width
RCA	16	0x0000 / 59b4 ²¹

²¹ After initialization the card can change the RCA register

Table 24: SSR register

Field	Bits	Bit width	Typ. value	Remark
Data bus width	511:510	2	0x2 ²²	4 bit width
Secured mode	509:509	1	0x0	not secured
Reserved for security	508:502	7	0x00	-
Reserved	501:496	6	0x00	-
SD card type	495:480	16	0x0000	Regular SD
Size protected area	479:448	32	0x0xxxxxxx	
Speed class	447:440	8	0x04	Class 10
Move performance	439:432	8	0x00	Sequential write
Allocation unit size	431:428	4	0x9	4 MiB
Reserved	427:424	4	0x0	
Erase unit size	423:408	16	0x8	8 AU
Erase unit timeout	407:402	6	0x04	4 seconds
Erase unit offset	401:400	2	0x1	1 second
UHS mode Speed Grade	399:396	4	0x1 / 0x3	UHS Grade 1 / 3
Allocation unit size in UHS mode	395:392	4	0x9	4MB/s
Reserved	391:312	80		

²² Value change in operation

9. Part Number Decoder

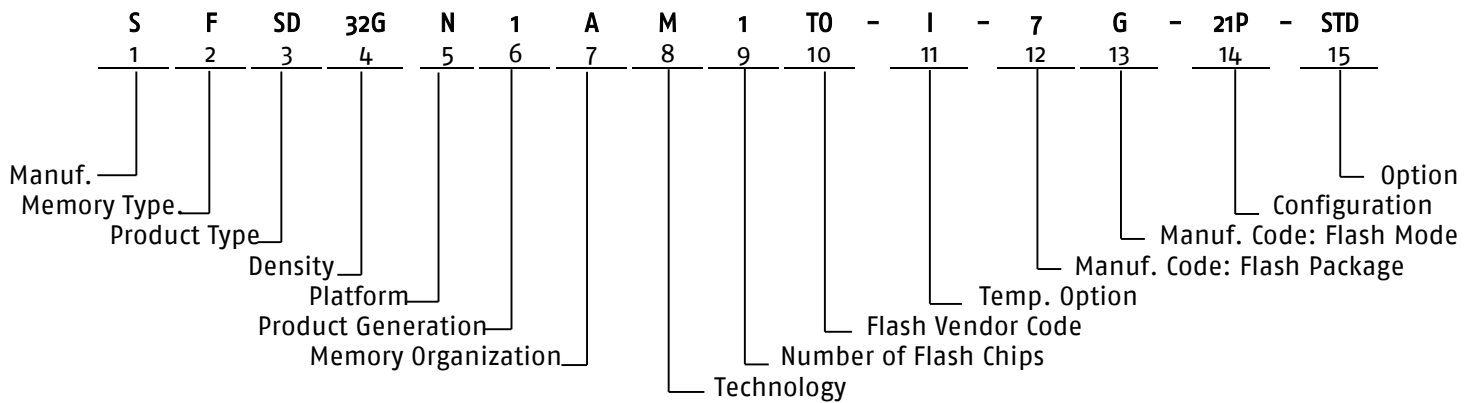

9.1 Manufacturer

Swissbit code	S
---------------	---

9.2 Memory Type

Flash	F
-------	---

9.3 Product Type

microSD Memory Card	SD
---------------------	----

9.4 Density

4 GBytes	004G
8 GBytes	008G
16 GBytes	016G
32 GBytes	032G

9.5 Platform

microSD Memory Card	N
---------------------	---

9.6 Product Generation

9.7 Memory Organization

x8	A
----	---

9.8 Technology

microSD Memory Card controller	S-5x Platform	M
--------------------------------	---------------	---

9.9 Channels

1 Flash channel	1
-----------------	---

9.10 Flash Code

Toshiba / Kioxia	T0
------------------	----

9.11 Temperature Option

Extended Temp. Range: -25°C to 85°C	E
Industrial Temperature Range: -40 °C to 85 °C	I

9.12 Die Classification

3D TLC MONO (single die package)	5
3D TLC DDP (dual die package)	6
3D TLC QDP (quad die package)	7

9.13 Pin Mode

Single nCE & R/nB	E
Dual nCE & R/nB	F
Quad nCE & R/nB	G

9.14 Drive configuration XYZ

X = Configuration

Configuration	X
UHS-I	2

Y = Firmware Revision

FW Revision	Y
High reliability series firmware	1

Z = Feature

Feature	Z
pSLC	P

9.15 Option

Swissbit / Standard	STD
---------------------	-----

10. Marking Specification

10.1 Top View

Figure 3: S-56u top view



10.2 Back side marking

Figure 4: S-56u label details



Part number

Manufacturing date
Lot code