

The SG1 provides absolute linear position up to a 10-ft. stroke range. Constructed with a rugged polycarbonate body, this model is available in an 80-inch or 120-inch stroke range and offers optional IP67 protection for wet or outdoor installations and an M12 connector for easy installation.

The SG1 uses a precision high-cycle plastic hybrid potentiometer and an extremely durable spring-loaded stainless steel measuring cable to provide an accurate reliable position feedback signal over the entire stroke. With its slim design and versatile mounting bracket, the SG1 has been designed to fit into spaces no other measurement device can. For the OEM customer, custom mounting hardware and electrical connections are available.



SG1

Cable Actuated Sensor

Voltage Divider Output Signal

Compact Mid-Range String Pot • Absolute Position

80, 120-inch Stroke Range Options

Polycarbonate Enclosure • IP67

In Stock for Quick Delivery

Specifications

Stroke Range Options	80 inches (2032 mm), 120 inches (3048 mm)
Output Signal	voltage divider (potentiometric)
Accuracy	.35% FS.
Repeatability	.05% FS.
Resolution	essentially infinite
Measuring Cable	.019-inch dia. nylon-coated stainless steel
Maximum Acceleration	10 g
Measuring Cable Tension	9 oz. (2,5 N) ±30%
Sensor	plastic-hybrid precision potentiometer
Input Resistance	10K ohms, ±10%
Power Rating, Watts	2.0 at 70°F
Recommended Maximum Input Voltage	30 V (AC/DC)
Output Signal Change Over Full Stroke Range	94% ±4% of V(+in)
Cycle Life	≥ 250,000
Electrical Connection	see ordering information
Enclosure	glass-filled polycarbonate
Environmental	IP 50 , IP67 (m12 connector & pigtail options)
Operating Temperature	-40° to 160° F (-40° to 70° C)
Weight, 80-inch (not including bracket)	.6 lbs. (272 g)
Weight, 120-inch (not including bracket)	1 lb. (453 g)

Electrical Connection

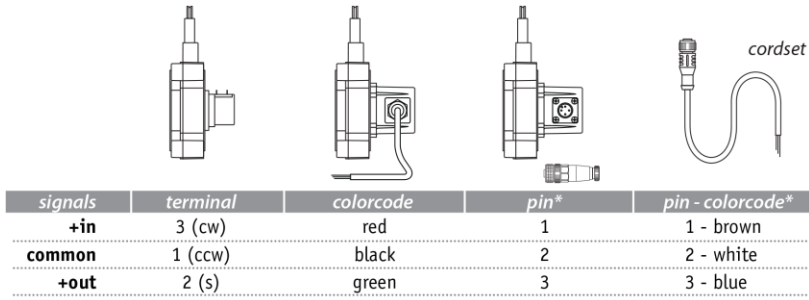

*note: connector pin 4 and the black wire on the cordset are NOT used.

Output Signal

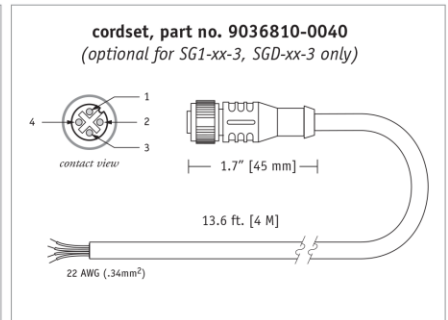
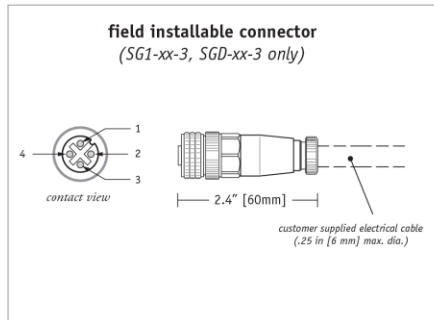
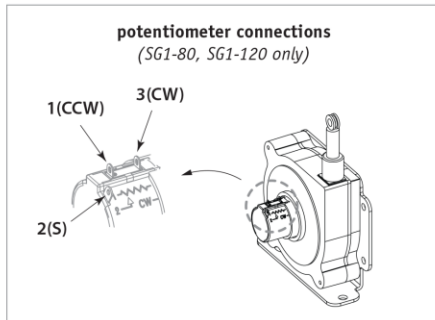
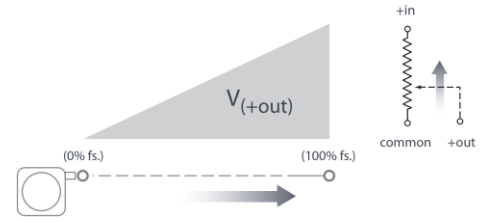

Mounting Options (SG1-80, SG1-80-2, SG1-80-3):

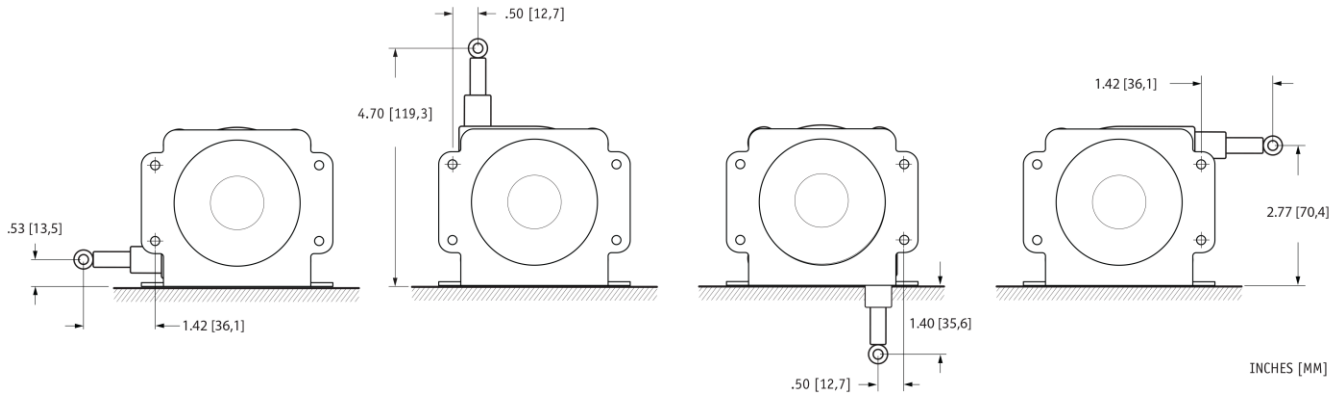

Mounting Options (SG1-120, SG1-120-2, SG1-120-3):

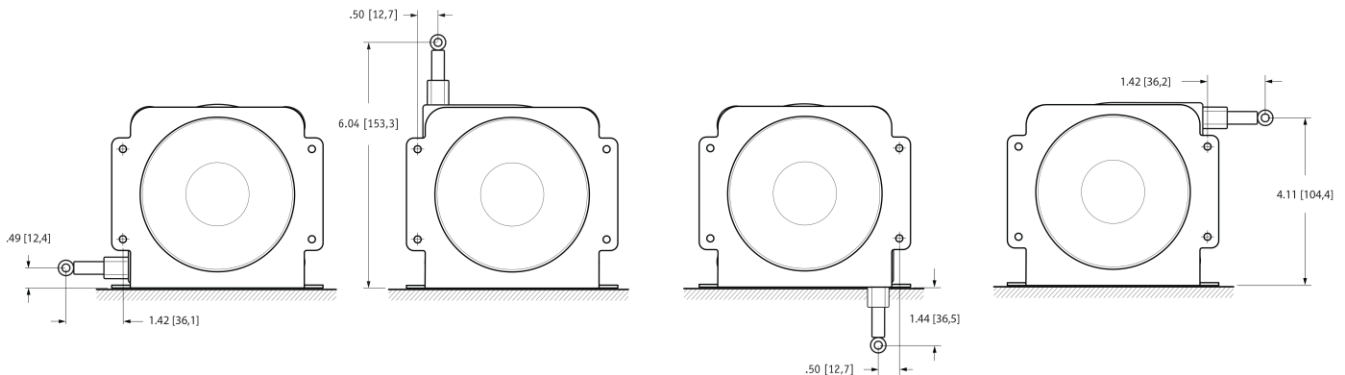

SG1-80 w/o Mounting Bracket:

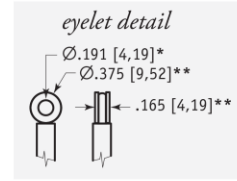
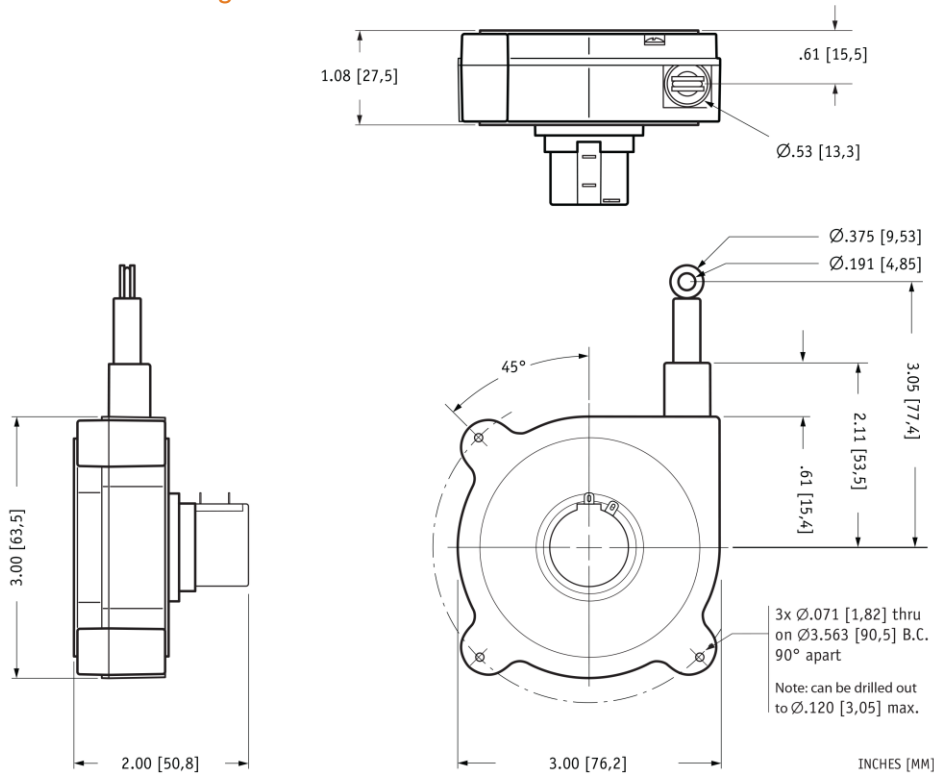

*tolerance = +.005 -.001 [+13 -.03]
 **tolerance = +.005 -.005 [+13 -.13]

SG1-120 w/o Mounting Bracket:

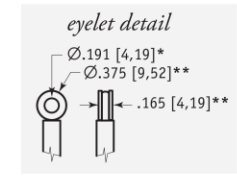
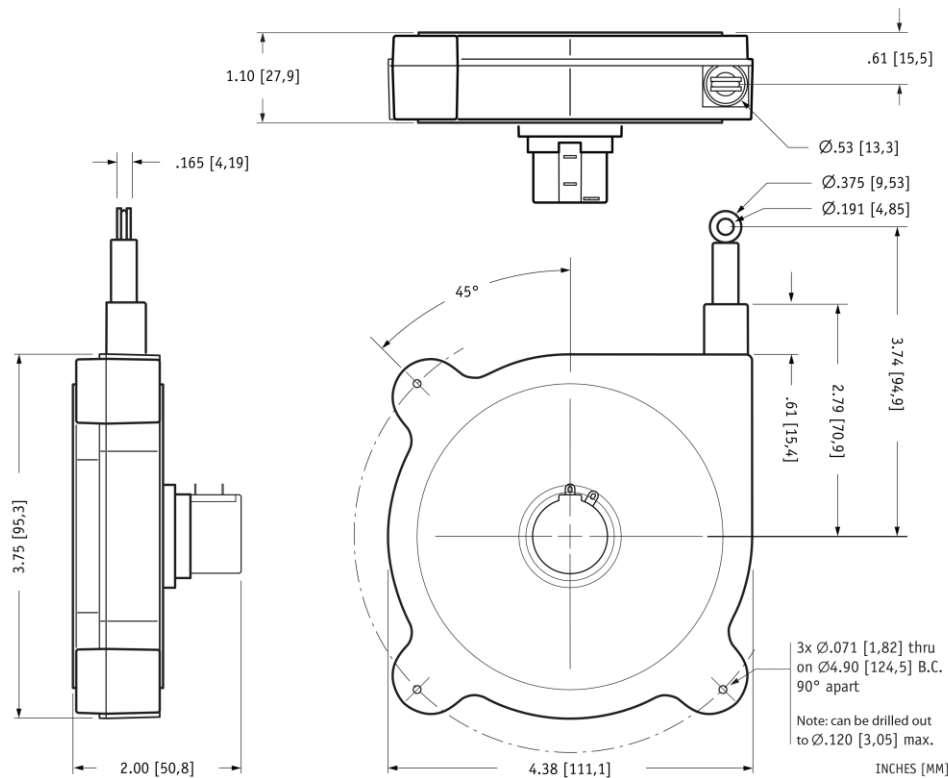

*tolerance = +.005 -.001 [+13 -.03]
 **tolerance = +.005 -.005 [+13 -.13]

SG1-80 w/ Mounting Bracket:

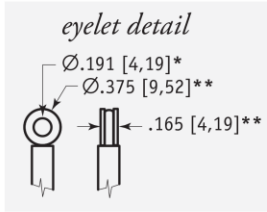

*tolerance = +.005 -.001 [+13 -.03]
 **tolerance = +.005 -.005 [+13 -.13]

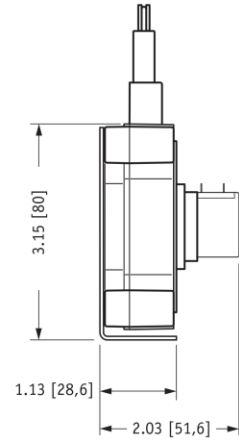
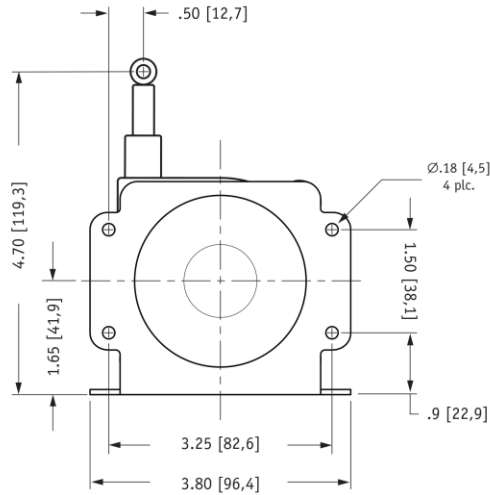
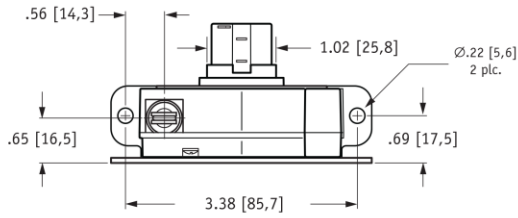

INCHES [MM]

SG1-120 w/ Mounting Bracket:

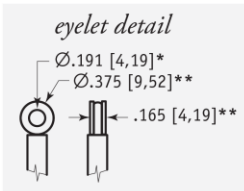

*tolerance = +.005 -.001 [+13 -.03]
 **tolerance = +.005 -.005 [+13 -.13]

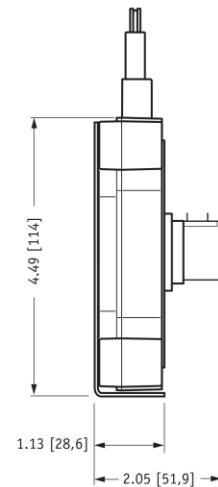
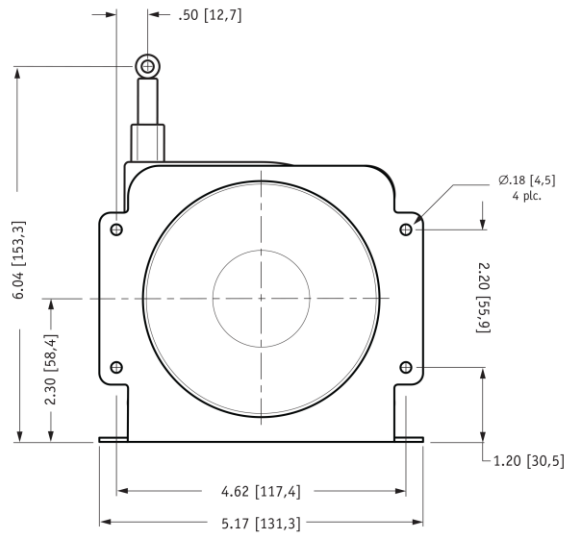
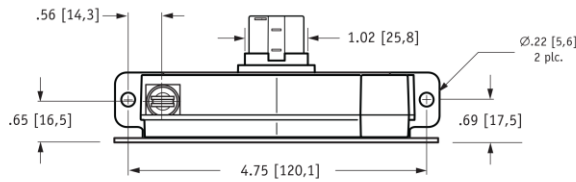

INCHES [MM]

SG1-80-2 w/ Mounting Bracket:

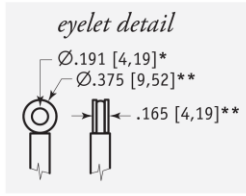

*tolerance = +.005 - .001 [+13 -.03]
**tolerance = +.005 - .005 [+13 -.13]

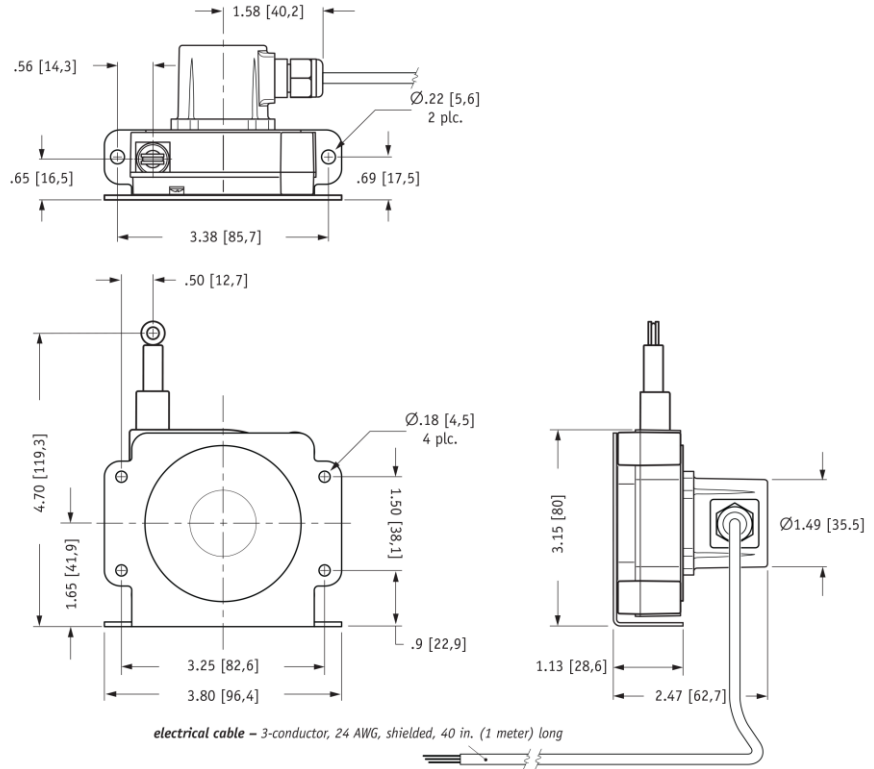

SG1-120-2 w/ Mounting Bracket:

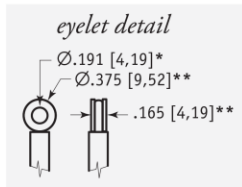

*tolerance = +.005 - .001 [+13 -.03]
**tolerance = +.005 - .005 [+13 -.13]

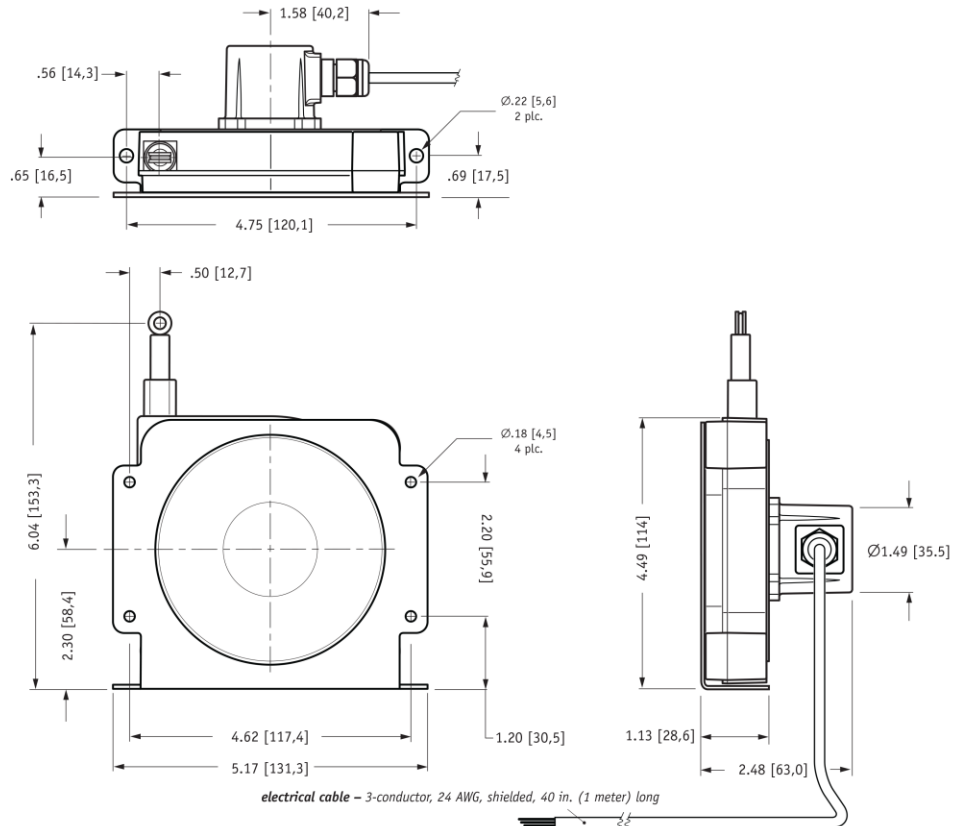

SG1-80-3 w/ Mounting Bracket:

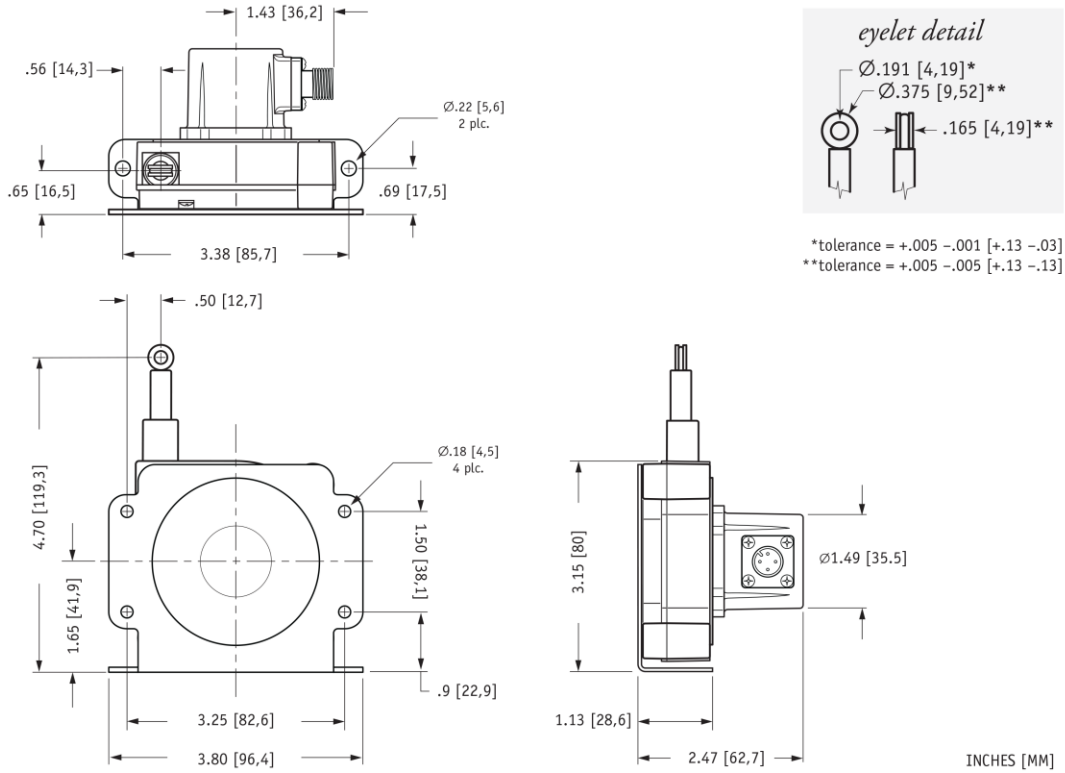

SG1-120-3 w/ Mounting Bracket:

