

# Smart Dupline® Aurora line, PIR Sensor and Luxmeter Type SHA4XP150L

CARLO GAVAZZI



- Passive infrared presence/movement detector with built-in luxmeter
- Light measuring range: 0 to 20 klux
- Developed to fit into wall socket and frames from Fuga, Niko, Biticino
- Indoor applications
- Operating distance: max 10 m
- Supplied by bus, no external power required
- Programmable white and blue LED for presence and movement detection
- Delivered with 2 white and 1 black push-button covers

## Product Description

The SHA4XP150L is a 150° PIR sensor to detect presence and/or movement in indoor installations with built-in luxmeter, combining two products in one. It is part of the smart-house concept and can be used to control lights, rollerblinds,

air-conditioning, intruder alarms and all the other functions supported by the smart-house system, in an automatic way depending on people-presence. This sensor is completely programmable via the SH tool.

## Ordering Key

**SH A4 X P 150 L**

smart-house \_\_\_\_\_  
Housing 44 x 44 mm \_\_\_\_\_  
Standard \_\_\_\_\_  
Pir Sensor \_\_\_\_\_  
Detection angle \_\_\_\_\_  
Luxmeter \_\_\_\_\_

## Type Selection

Housing	Colour	LEDs	Supply by bus
44 x 44 mm	White / Black *	1 white / 1 blue	SHA4XP150L

\*Delivered with white and black push-button covers.

## Input Specifications

<b>Infrared inputs</b>	
Lens	Dual detecting zones
Angle	150°
<b>Operating distance</b>	≤ 10 m
<b>Luxmeter</b>	
Characteristic deviation	-3% to + 3%
Response time	It depends on the number of variables in the system
Sensor range	0 to 20 kLux
Accuracy over temperature	0° to 40°C ± 10% -30° to 0°C ± 15% +40° to 60°C ± 20%

## Dupline® Specifications

Voltage	8.2 V
Maximum dupline® voltage	10 V
Minimum dupline® voltage	5.5 V
Maximum dupline® current	5.8 mA

## Output Specifications

Output LED	1 blue / 1 white
------------	------------------

## Supply Specifications

Power supply	Supplied by bus
--------------	-----------------

## General Specifications

<b>Power ON delay</b>	Typ. 10 s.	<b>Weight</b>	50 g
<b>Address assignment</b>	Automatic: the controller recognises the module through the SIN (Specific Identification Number) that has to be inserted in the SH tool.	<b>CE Marking</b>	Yes
<b>Environment</b>		<b>EMC</b>	
Degree of protection	IP 20	Immunity	EN 61000-6-2
Pollution degree	3 (IEC 60664)	- Electrostatic discharge	EN 61000-4-2
Operating temperature	0° to +50°C (+32° to +122°F)	- Radiated radiofrequency	EN 61000-4-3
Storage temperature	-20° to +70°C (+4° to +158°F)	- Burst immunity	EN 61000-4-4
Humidity (non-condensing)	20 to 80% RH	- Surge	EN 61000-4-5
<b>Connection</b>		- Conducted radio frequency	EN 61000-4-6
Screwless detachable	0.2 to 1.5 mm <sup>2</sup>	- Power frequency magnetic fields	EN 61000-4-8
D+	Signal	- Voltage dips, variations, interruptions	EN 61000-4-11
D-	GND	Emission	EN 61000-6-3
<b>Housing</b>		- Conducted and radiated emissions	CISPR 22 (EN55022), cl. B
Back part dimensions	44 x 44 x 25.2 mm	- Conducted emissions	CISPR 16-2-1 (EN55016-2-1)
Back part + front dimensions	44 x 44 x 43 mm	- Radiated emissions	CISPR 16-2-3 (EN55016-2-3)
Back part material	Plastic, transparent		
Push button covers	Plastic white (RAL 9010) Plastic clear white (RAL 9016) Plastic black		
Accessories	Transparent plastic ring for Bticino frame		

## Mode of Operation

This PIR sensor responds to any fluctuation in infrared heat radiation, so any object or human presence changes the thermal image detected by the sensor when entering its field of vision.

The sensor is equipped with a segmented lens that divides the field of vision into active and passive zones (zones not visible to the sensor, see figures "Horizontal and Vertical sensitive area"). When a heat source crosses these zones, the sensor detects the change in infrared radiation and presence and/or movement are recognised.

How sensitive and fast the sensor has to be to detect presence and/or movement can be programmed by means of four parameters, by means

of the SH tool.

The four parameters are: mode of detecting the crossing of active zones, sensitivity, the number of pulses and the time window in which these pulses have to be detected. These four parameters have to be set for both presence and movement recognition.

Movement is used by the system in the intruder alarm function and to switch the light on, while presence is used in the light function to reload the energy-save timer (i.e. each time presence is detected, the energy-save timer starts counting from the beginning).

### 1) Mode of detection

A: one border between the active and the passive zone has to be crossed to give a

pulse signal. This option has to be selected for presence detection and movement and turns the light on as soon as a person moves from an active to a passive area or vice versa (very quick response).

B: two borders have to be crossed to give a pulse signal. The person has to move from an active area to another active area, passing through a passive one or vice versa.

This option is recommended for sensors used in the intruder alarm function, in order to avoid false alarms.

### 2) Sensitivity

A number can be set from 3 to 100: the smaller this value is, the longer the detection distance, but the higher the sensitivity to heating sources.

In the figures "Horizontal and Vertical sensitive area", three examples of different sensitivity can be seen.

### 3) Number of pulses

The number of pulses is calculated according to mode A or B before sending a people detection message to the controller. This can be set from 1 to 8.

### 4) Time window

This is the time interval within which the predefined number of pulses is detected. It can be set from 1 to 10 seconds.

In the table below is an example of settings which, of course, might depend on environmental conditions, application and type of installation.

	Presence	Movement (light fx)	Movement (alarm fx)
Mode of detection	A	A	B
Sensitivity	10..30	30..70	50..100
Number of pulses	1	1	3
Time window	10	2	10

## Mode of Operation (cont.)

### Active and passive zones

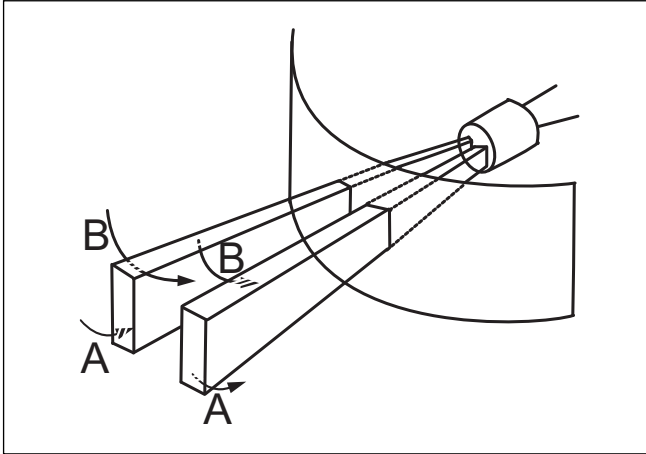

### Vertical sensitive area

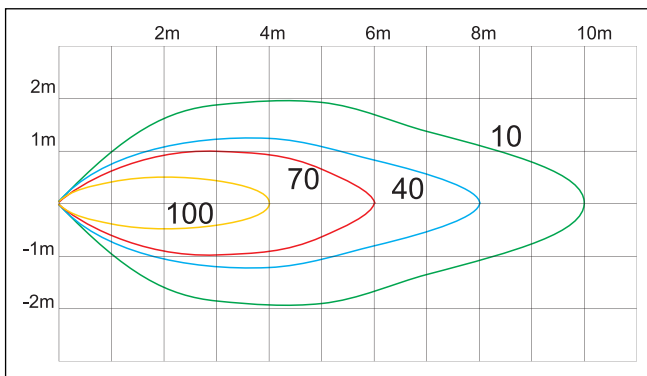

### Horizontal sensitive area

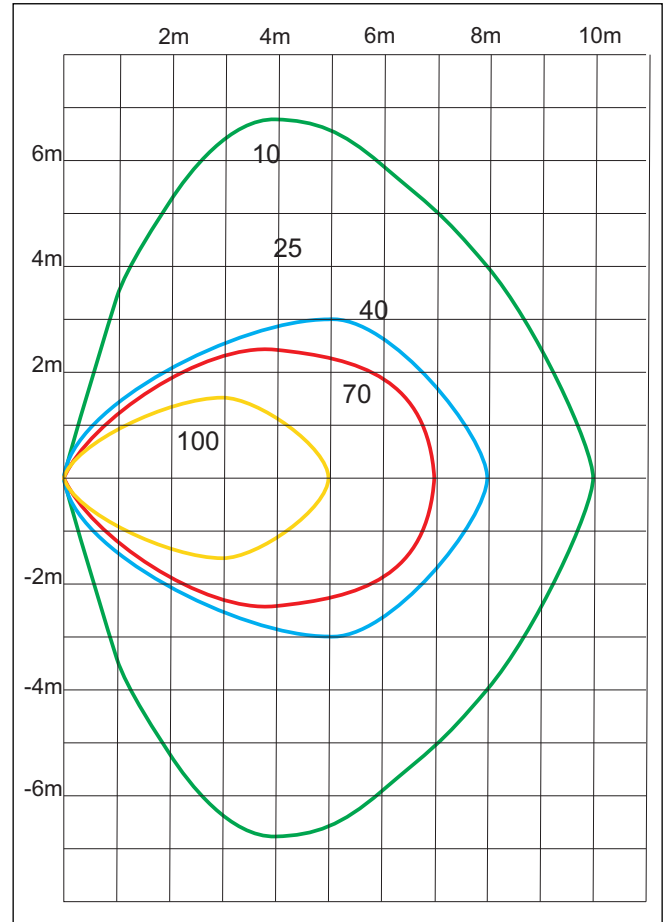

### LED programming

There are two configurable LEDs (one white and one blue) built in the SHA4XP150L to be programmed.

**White LED:** the user can select one of the following options

1. LED always OFF

2. LED flashes shortly every seconds if a presence/ movement is detected  
If the white LED is not programmed, it is always OFF.

**Blue LED:** the user can select one of the following options

1. LED always OFF
2. LED flashes shortly every

seconds if a presence/ movement is detected

3. LED flashes shortly every seconds if it is used as feedback of a function status

If the blue LED is not programmed, it is always OFF.

### Addressing

No addressing is needed since the module is provided with a specific identification number (SIN): the user has only to insert the SIN number in the SH tool when creating the system configuration.

Used channel: 2 input channels, 1 output channel.