

### Description

The Si21692D integrates two separate high-performance digital demodulators for the DVB-T2/T/C, DVB-S2/S and DVB-S2X standards into a single compact package. Leveraging Skyworks' proven digital demodulation architecture, the Si21692D achieves excellent reception performance for each media while significantly minimizing front-end design complexity, cost, and power dissipation. Connecting the Si21692D to both a dual terrestrial/cable TV tuner, and a dual satellite tuner, results in a high-performance and cost optimized TV front-end solution.

Skyworks' internally-developed DVB-T2 (including T2-Lite) demodulators support all modes specified by the DVB-T2 standard (V1.4.1). Main features of the DVB-T2 mode are, SISO and MISO support, FEF management, fully autonomous signal acquisition including automatic L1 signaling parsing support for all pilot patterns, and DVB-T2/T auto-detection.

The DVB-T and DVB-C, including ITU-T J.83 annex B, demodulators are enhanced versions of proven and broadly used Si2164/67/68/69 Skyworks devices.

The satellite reception allows demodulating widespread DVB-S, DIRECTV™ (DSS), DVB-S2, DIRECTV™ (AMC) legacy standards, and new Part II of DVB-S2 (S2X) satellite broadcast standard. A zero-IF interface (differential) allows for a seamless connection to market proven satellite silicon tuners. It also integrates two DiSEqC™ 2.0 LNB interfaces for satellite dish control and, for each satellite demodulator, an equalizer to compensate for echoes in long cable feeds from the LNB to the satellite tuner RF input.

The Si21692D offers an on-chip blind scanning algorithm for DVB-S/S2/S2X and DVB-C standards, as well as blind lock function. The Si21692D embeds two independent programmable transport stream interfaces which provide a flexible range of output modes, including a cross-bar functionality, and are fully compatible with all MPEG decoders or conditional access modules to support any customer application.

### Features

- Pin-to-pin compatible with all dual demodulator family: Si216x2 and Si218x2
- API compatible with all single and all dual demodulators
- DVB-T2 and T2-Lite (ETSI EN 302 755-V1.4.1)
  - Bandwidth: 1.7, 5, 6, 7 or 8 MHz
  - NorDig Unified 2.5 and D-Book 8 compliant
- DVB-T (ETSI EN 300 744)
  - NorDig Unified 2.5, D-Book 8 compliant
- DVB-C (ETSI EN 300 429) / ITU-T J.83 Annex A/B/C
  - 1 to 7.2 MSymbol/s, C-Book compliant
- DVB-S2 (ETSI EN 302 307-1 V1.4.1)
  - QPSK/8PSK demodulator
- DVB-S2X (ETSI EN302 307-2 V1.1.1)
  - QPSK/8PSK, 8/16/32APSK demodulator
  - Roll-off factors from 0.05 to 0.35
  - Channel bonding for TS transmission supported
- DVB-S (ETSI EN 300 421) and DSS supported
- Dual DiSEqC™ 2.x interface, Unicable support
- 1 to 45 MSps for all satellite standards (<40 MSps in 32APSK)
- I<sup>2</sup>C serial bus interfaces (master and host)
- Upgradeable with firmware patch download via fast SPI or I<sup>2</sup>C (broadcast mode supported)
- Dual independent differential IF input for T/C tuners and differential ZIF I/Q inputs for satellite tuners
- GPIOs and multi-purpose ports (two per demodulator)
- Separate flexible TS interfaces with serial or parallel outputs and cross-bar feature
- Fast lock times for all standards
- Only two power supplies: 1.2 and 3.3 V
- 8x8 mm, QFN-68 pin package, Pb-free/RoHS compliant

### Applications

- Multi-receiver iDTV: on-board or in a NIM
- Advanced multimedia PVR STBs
- PC-TV accessories
- PVR, DVD, and Blu-Ray disc recorders

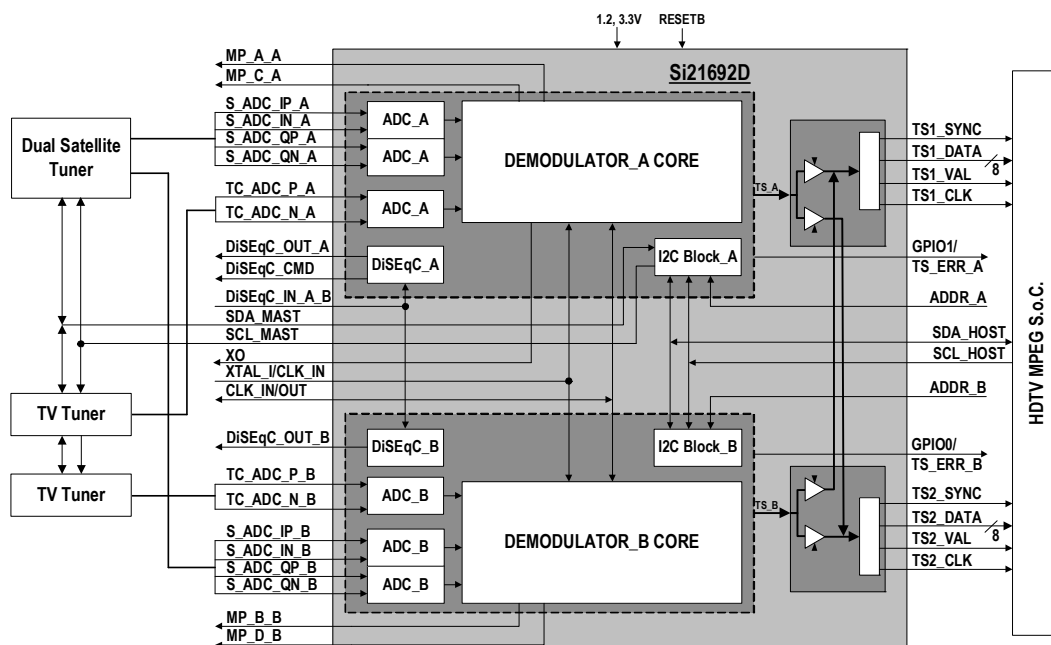
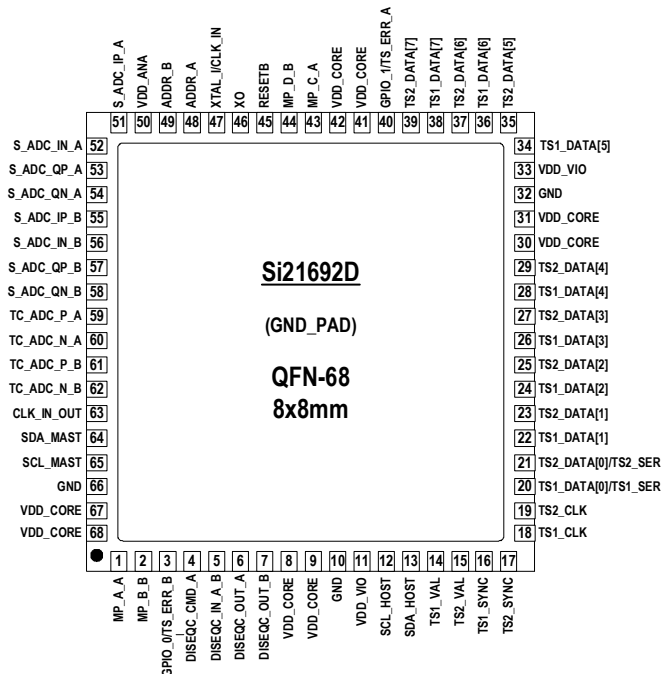

**Table 1. Selected Electrical Specifications**

(T<sub>A</sub> = -10 to 70 °C).

Parameter	Test Condition	Min	Typ	Max	Unit
<b>General</b>					
Input clock reference		4	—	30	MHz
Supported XTAL frequency		16	—	30	MHz
Total power consumption for each demodulator	DVB-T2 <sup>1</sup>	—	356	—	mW
	DVB-T <sup>2</sup>	—	182	—	mW
	DVB-C <sup>3</sup>	—	142	—	mW
	DVB-S2 <sup>4</sup>	—	421	—	mW
	DVB-S <sup>5</sup>	—	230	—	mW
Thermal resistance (θ <sub>JA</sub> )	4 layer PCB	—	42	—	°C/W
<b>Power Supplies</b>					
V <sub>DD_VCORE</sub>		1.14	1.20	1.30	V
V <sub>DD_VANA</sub>		3.00	3.30	3.60	V
V <sub>DD_VIO</sub>		3.00	3.30	3.60	V
<b>Notes:</b>					
1. Test conditions: 8 MHz, 256-QAM, 32K FFT, CR = 3/5, GI = 1/128, PP7, C/N at picture failure, parallel TS.					
2. Test conditions: 8 MHz, 8K FFT, 64-QAM, parallel TS.					
3. Test conditions: 6.9 Mbaud, 256-QAM, parallel TS.					
4. Test conditions: 32 Mbaud, CR = 3/5, 8PSK, pilots On, C/N at picture failure, parallel TS.					
5. Test conditions: 30 Mbaud, CR = 7/8, at QEF: BER = 2 x 10 <sup>-4</sup> , parallel TS.					

### Pin Assignments



**Table 1. Selection Guide**

Part #	Description
Si21692-D60-GM/R	Dual Digital TV Demodulator for DVB-T2/S2/S2X/T/C/S, 8x8 mm QFN-68