

Description

Silicon Laboratories' Si4455 is an easy-to-use, low current, sub-GHz EZRadio® transceiver. Covering all major bands, it combines plug-and-play simplicity with the flexibility needed to handle a wide variety of applications. The compact 3x3 mm package size combined with a low external BOM count makes the Si4455 both space efficient and cost effective. The +13 dBm output power and excellent sensitivity of -116 dBm allows for a longer operating range, while the low current consumption of 18 mA TX (at 10 dBm), 10 mA RX, and 50 nA standby, provides for superior battery life. By fully integrating all components from the antenna to the GPIO or SPI interface to the MCU, the Si4455 makes realizing this performance in an application easy. Design simplicity is further exemplified in the Wireless Development Suite (WDS) user interface module. This configuration module provides simplified programming options for a broad range of applications in an easy to use format that results in both a faster and lower risk development. Like all Silicon Laboratories' EZRadio devices, the Si4455 is fully compliant with most worldwide regulatory standards such as FCC, ETSI, and ARIB.

Features

- Frequency range = 283–960 MHz
- Receive sensitivity = -116 dBm
- Modulation
 - (G)FSK
 - OOK
- Max output power = +13 dBm
- Low active power consumption
 - 10 mA RX
 - 18 mA TX @ +10 dBm
- Low standby current = 50 nA
- Max data rate = 500 kbps
- Power supply = 1.8 to 3.6 V
- TX and RX 64 byte FIFOs
- Automatic frequency control (AFC)
- Automatic gain control (AGC)
- Integrated battery voltage sensor
- Packet handling including preamble, sync word detection, and CRC
- Low BOM
- 20-Pin 3x3 mm QFN package

Applications

- Remote control
- Home security and alarm
- Telemetry
- Garage and gate openers
- Remote keyless entry
- Home automation
- Industrial control
- Sensor networks
- Health monitors

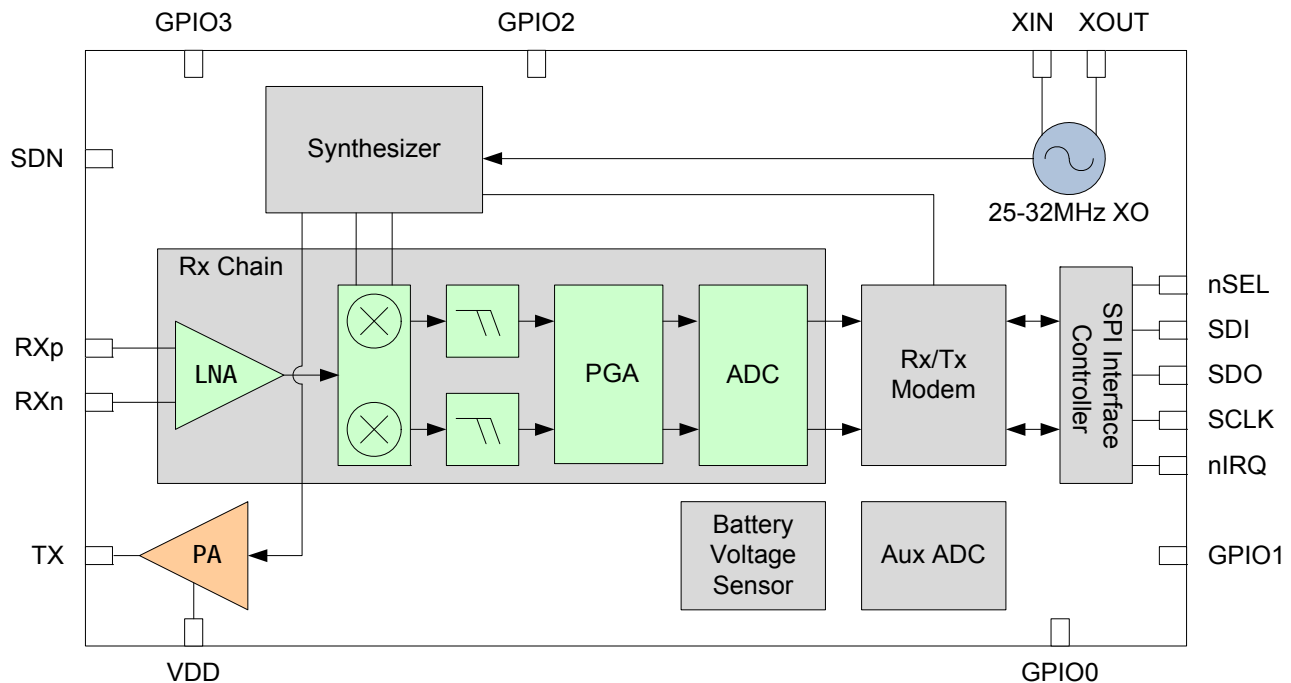

Selected Electrical Specification

Parameter	Symbol	Test Condition	Min	Typ	Max	Unit
Supply Voltage	V _{DD}		1.8	3.3	3.6	V
Frequency Range	F _{TX/RX}		283	—	350	MHz
			425	—	525	MHz
			850	—	960	MHz
Current Consumption	I _{Shutdown}		—	30	—	nA
	I _{Standby}		—	50	—	nA
	I _{RX}		—	10	—	mA
	I _{TX}	+10 dBm output power, 868 MHz	—	18	—	mA
Rx Sensitivity	P _{RX_2}	BER < 0.1%, 2.4 kbps, GFSK, BT = 0.5, ΔF = 25kHz, 114 kHz Rx BW	—	-116	—	dBm
	P _{RX_OOK}	BER < 0.1%, 1 kbps, 185 kHz Rx BW, OOK, PN15 data	—	-113	—	dBm
Selectivity ²	C/I _{1-CH}	±1 Channel Offset	—	-56	—	dB
	C/I _{2-CH}	±2 Channel Offset	—	-59	—	dB
Blocking ²	200k _{BLOCK}	200 kHz–1 MHz Offset	—	-58	—	dB
	1M _{BLOCK}	1 MHz Offset	—	-61	—	dB
	8M _{BLOCK}	8 MHz Offset	—	-79	—	dB
Image Rejection	Im _{REJ}	Rejection at the image frequency IF=468kHz	—	-40	—	dB
Data Rate	DR _{FSK}	(G)FSK Modulation	1.0	—	500	kbps
	DR _{OOK}	OOK Modulation	0.5	—	120	kbps
Output Power	P _{TX}		-40	—	+13	dBm

Notes:

1. Test Conditions: 3.3 VDC V_{DD}, 25 °C, external reference signal (X_{IN}) = 1.0 V_{PP} at 30 MHz, centered around 0.8 VDC. Sensitivity measured at 434 MHz.
2. Desired reference signal 3 dB above sensitivity, BER<0.1%, Interferer is CW and desired modulation with 1.2 kbps, ΔF = 5.2 kHz, GFSK with BT = 0.5, Rx BW = 58 kHz, 100 kHz channel spacing.

Ordering Guide

Part Number*	Description	Package Type	Operating Temperature
Si4455-B1A-FM	EZRadio Transceiver	3x3 QFN-20 Pb-free	-40 to 85 °C

*Note: Add an "R" at the end of the device part number to denote tape and reel option.

Application Circuit

