

### Description

The Si4685 single-chip digital receiver is one member of a family of 100% CMOS digital radio broadcast receiver ICs from Skyworks. The Si468x family offers a complete and cost-effective digital radio solution integrating the RF tuner, baseband and audio processing on a single die. The high level of integration provides significant customer benefits compared to traditional digital radio solutions, including a reduction in system implementation complexity, validation and testing, and improved reliability and manufacturability.

The Si4685 offers VHF Band III (168-240 MHz) reception capability and is fully compliant with ETSI EN 300 401 and ETSI TS 102 563. The Si4685 supports DAB and DAB+ via an integrated source decoder that supports both MPEG Audio Layer 2 (DAB) and HE-AAC V2 (DAB+). The Si4685 supports data services such as Dynamic Labels, Intellitext, Electronic Program Guide (EPG), Slideshow and Journaline<sup>®</sup> with the appropriate external decoders.

The Si4685 additionally supports worldwide AM/FM radio reception and incorporates a fully integrated decoder for the European Radio Data System (RDS) and the North American Radio Broadcast Data System (RDBS) including all required symbol decoding, block synchronization, error detection, and error correction functions.

### Features

- Worldwide FM band support (76–108 MHz)
- Worldwide AM band support (520–1710 kHz)
- Advanced RDS/RBDS decoder
- DAB, DAB+ Band III support (168–240 MHz)
- Supports WorldDMB Receiver Profiles 1 and 2
- Integrated OFDM channel demodulator
- Integrated de-interleaving SRAM
- I<sup>2</sup>S digital audio out with ASRC
- Integrated 97 dB stereo audio DAC
- Concurrent I<sup>2</sup>S/L-R stereo audio out
- Full range of signal quality metrics
- Fully-integrated VCO / PLL / synthesizer
- SPI and I<sup>2</sup>C host control interfaces
- QFN 48-pin, 7x7x0.85 mm

### Applications

- Clock and tabletop radios
- Stereo boomboxes
- Mini/micro systems
- Docking stations

For more information, visit the Si468x Digital Radio Receivers web page:

[www.skyworksinc.com/en/Products/Audio-and-Radio/Si468x-Digital-Radios](http://www.skyworksinc.com/en/Products/Audio-and-Radio/Si468x-Digital-Radios)

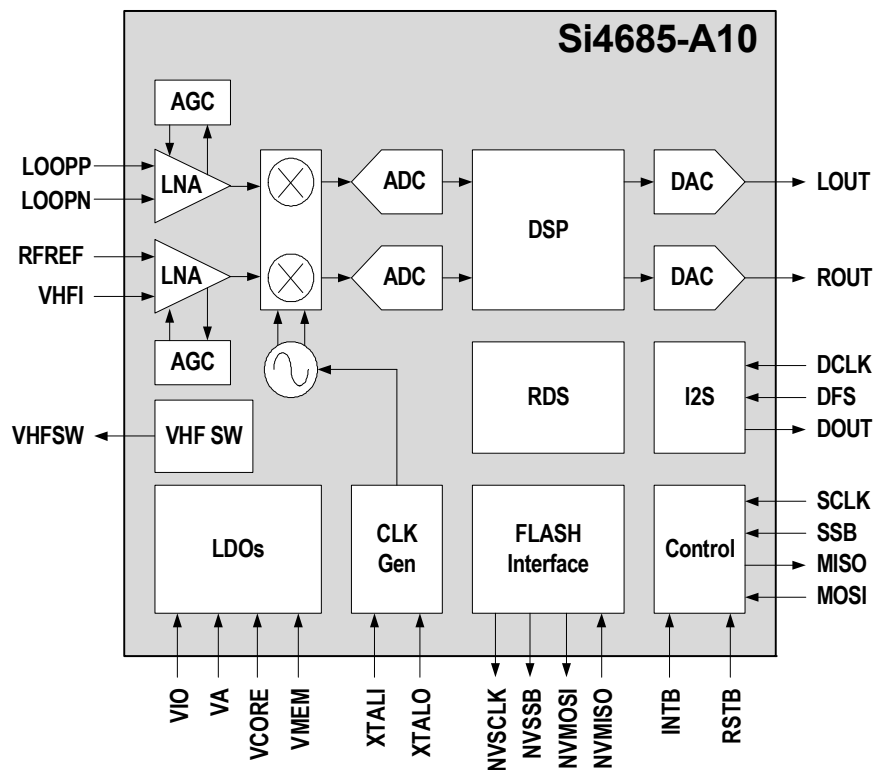

### Selected Electrical Specifications

Parameter	Symbol	Test Conditions	Min	Typ	Max	Units
Ambient Temperature	$T_A$		-40	25	85	°C
Analog Supply Voltage	$V_A$		1.71	1.8	2.0	V
Interface Supply Voltage	$V_{IO}$		1.62	1.8	3.6	V
Core Digital Supply Voltage	$V_{CORE}$		1.62	1.8	2.0	V
Memory Supply Voltage	$V_{MEM}$		1.62	1.8	2.0	V
<b>Analog FM</b>						
Input Frequency	$F_{rf}$		76	—	108	MHz
Seek/Tune Time			—	—	60	ms/ch
<b>Analog AM</b>						
Input Frequency	$F_{rf}$		520	—	1710	kHz
Seek/Tune Time			—	—	60	ms/ch
<b>DAB/DAB+</b>						
Input Frequency	$F_{rf}$		168	—	240	MHz
Ensemble Acquisition Time		For a valid channel, after power-up RF level = -47 dBm	—	710	—	ms

### Si4685-A10-GM

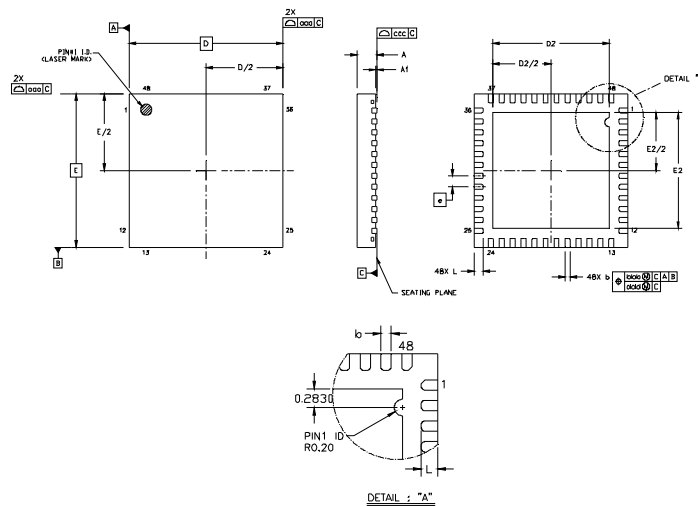

Dimension	Min	Nom	Max
A	0.80	0.85	0.90
A1	0.00	0.02	0.05
b	0.18	0.25	0.30
D		7.00 BSC	
D2	5.20	5.30	5.40
e		0.50 BSC	
E		7.00 BSC	
E2	5.20	5.30	5.40
L	0.30	0.40	0.50
aaa		0.15	
bbb		0.10	
ddd		0.05	
eee		0.08	

**Notes:**

1. All dimensions are shown in millimeters (mm) unless otherwise noted.
2. Dimensioning and tolerancing per ASME Y14.5M-1994.
3. This drawing conforms to JEDEC Outline MO-220, Variation VKKD-4.
4. Recommended card reflow profile is per the JEDEC/IPC J-STD-020 specification for Small Body Components.