

Description

The Si4689 single-chip digital receiver is one member of a family of 100% CMOS digital radio broadcast receiver ICs from Skyworks. The Si468x family offers a complete and cost-effective digital radio solution integrating the RF tuner, baseband, and audio processing on a single die. The high level of integration provides significant customer benefits compared to traditional digital radio solutions, including a reduction in system implementation complexity, validation and testing, and improved reliability and manufacturability.

The Si4689 is compatible with the iBiquity Digital and NRSC-5 standards for In-Band-On-Channel (IBOC) digital radio broadcasting, integrating digital channel demodulation and decoding functions, along with audio decoding and IBOC analog-digital blend. The Si4689 supports IBOC multicasting, as well as the full-range of HD Radio data services, such as PSD, Artist Experience, iTunes® Tagging, Bookmark and real-time Traffic, with the appropriate external decoders.

The Si4689 also offers VHF Band III (168–240 MHz) reception capability and is fully compliant with ETSI EN 300 401 and ETSI TS 102 563. The Si4689 delivers DAB and DAB+ via an integrated source decoder that supports both MPEG Audio Layer 2 (DAB) and HE-AAC V2 (DAB+). The Si4689 supports data services such as Dynamic Labels, Intellitext, Electronic Program Guide (EPG), Slideshow, and Journaline® with the appropriate external decoders.

Features

- Worldwide FM band support (76–108 MHz)
- Worldwide AM band support (520–1710 kHz)
- Advanced RDS/RBDS decoder
- FM HD Radio™ support with on-chip IBOC blend
- DAB, DAB+ Band III support (168–240 MHz)
- Supports WorldDMB Receiver Profile 1
- Integrated OFDM channel demodulator
- Integrated de-interleaving SRAM
- I²S digital audio out with ASRC
- Integrated 97 dB stereo audio DAC
- Concurrent I²S/L-R stereo audio out
- Full range of signal quality metrics
- Fully-integrated VCO / PLL / synthesizer
- SPI and I²C host control interfaces
- QFN 48-pin, 7x7x0.85 mm

Applications

- Clock and tabletop radios
- Stereo boomboxes
- Mini/micro systems
- Docking stations

For more information, visit the Si468x Digital Radio Receivers web page:

www.skyworksinc.com/en/Products/Audio-and-Radio/Si468x-Digital-Radios

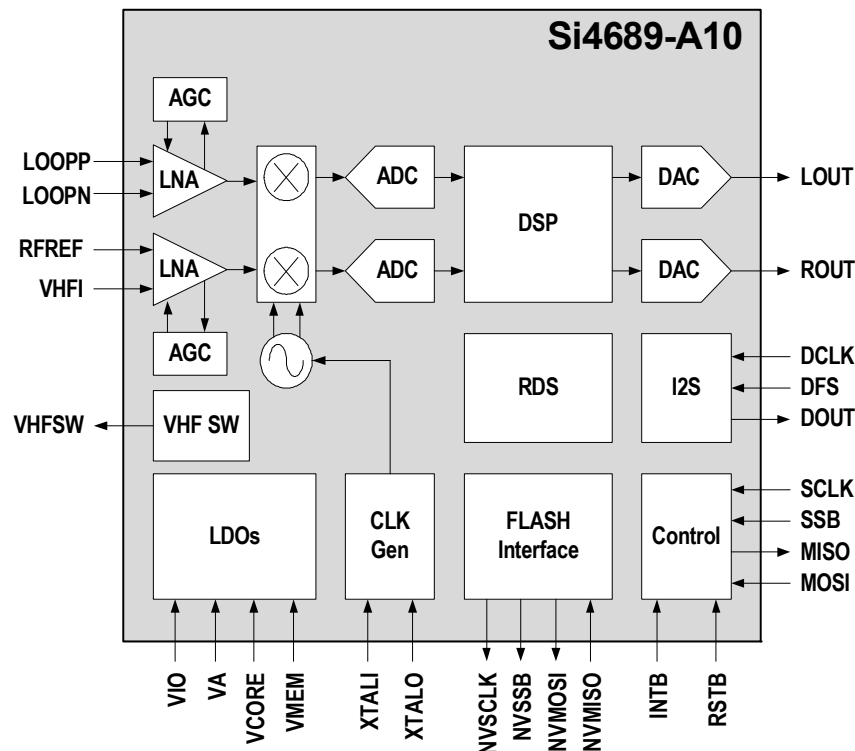

Selected Electrical Specifications

Parameter	Symbol	Test Conditions	Min	Typ	Max	Units
Ambient Temperature	T_A		-40	25	85	°C
Analog Supply Voltage	V_A		1.71	1.8	2.0	V
Interface Supply Voltage	V_{IO}		1.62	1.8	3.6	V
Core Digital Supply Voltage	V_{CORE}		1.62	1.8	2.0	V
Memory Supply Voltage	V_{MEM}		1.62	1.8	2.0	V
Analog FM						
Input Frequency	F_{rf}		76	—	108	MHz
Seek/Tune Time			—	—	60	ms/ch
FM HD						
Input Frequency	F_{rf}		87.5	—	108	MHz
Seek/Tune Time			—	—	60	ms/ch
Analog AM						
Input Frequency	F_{rf}		520	—	1710	kHz
Seek/Tune Time			—	—	60	ms/ch
AM HD						
Input Frequency	F_{rf}		520	—	1710	kHz
Seek/Tune Time			—	—	60	ms/ch
DAB/DAB+						
Input Frequency	F_{rf}		168	—	240	MHz
Ensemble Acquisition Time		For a valid channel, after power-up RF level = -47 dBm	—	710	—	ms

Si4689-A10-GM

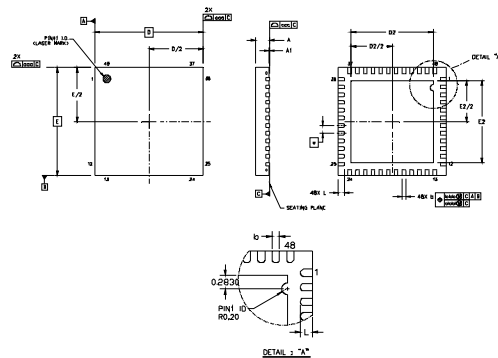

Dimension	Min	Nom	Max
A	0.80	0.85	0.90
A1	0.00	0.02	0.05
b	0.18	0.25	0.30
D		7.00 BSC	
D2	5.20	5.30	5.40
e		0.50 BSC	
E		7.00 BSC	
E2	5.20	5.30	5.40
L	0.30	0.40	0.50
aaa		0.15	
bbb		0.10	
ddd		0.05	
eee		0.08	

Notes:

- All dimensions are shown in millimeters (mm) unless otherwise noted.
- Dimensioning and tolerancing per ASME Y14.5M-1994.
- This drawing conforms to JEDEC Outline MO-220, Variation VKKD-4.
- Recommended card reflow profile is per the JEDEC/IPC J-STD-020 specification for Small Body Components.