



Si47xx EVALUATION BOARD USER'S GUIDE

1. Introduction

Thank you for purchasing the Skyworks, Inc. Si47xx Evaluation Board (EVB). The EVB and associated software have been designed to speed up the overall development process. We look forward to working with you, and have posted support articles, answers to frequently asked questions, and application notes at www.skyworksinc.com. Table 1 describes all of the available products and features in the Si47xx family.

Table 1. Product Family Function

Part Number	General Description	FM Transmitter	FM Receiver	AM Receiver	SW/LW Receiver	WB Receiver	RDS	High Performance RDS	RPS	SAME	Digital Input	Digital Output	Embedded FM antenna	AEC-Q100 Qualified	Package Size (mm)
Si4700	FM Receiver		✓												4x4
Si4701	FM Receiver with RDS		✓				✓								4x4
Si4702	FM Receiver		✓												3x3
Si4703	FM Receiver with RDS		✓				✓								3x3
Si4704	FM Receiver		✓										✓		3x3
Si4705	FM Receiver with RDS		✓				✓	²			✓	✓			3x3
Si4706 ¹	High Performance RDS Receiver		✓				✓	✓			✓	✓			3x3
Si4707 ¹	WB Receiver with SAME					✓				✓					3x3
Si4708	FM Receiver		✓												2.5x2.5
Si4709	FM Receiver with RDS		✓				✓								2.5x2.5
Si4710	FM Transmitter	✓									✓		✓		3x3
Si4711	FM Transmitter with RDS	✓					✓				✓		✓		3x3
Si4712	FM Transmitter with RPS	✓							✓		✓		✓		3x3
Si4713	FM Transmitter with RDS & RPS	✓					✓		✓		✓		✓		3x3
Si4720	FM Transceiver	✓	✓						✓		✓		✓		3x3
Si4721	FM Transceiver with RDS	✓	✓				✓		✓		✓	✓	✓		3x3
Si4730	AM/FM Receiver		✓	✓											3x3
Si4731	AM/FM Receiver with RDS		✓	✓			✓	²				✓			3x3

Notes:

- Si4706, Si4707, and Si474x are covered under NDA.
- High Performance RDS is available in Si4705/31/35/85-D50 and later.

Si47xx-EVB

Table 1. Product Family Function (Continued)

Part Number	General Description	FM Transmitter	FM Receiver	AM Receiver	SW/LW Receiver	WB Receiver	RDS	High Performance RDS	RPS	SAME	Digital Input	Digital Output	Embedded FM antenna	AEC-Q100 Qualified	Package Size (mm)
Si4734	AM/SW/LW/FM Receiver		✓	✓	✓										3x3
Si4735	AM/SW/LW/FM Receiver with RDS		✓	✓	✓		✓	2				✓			3x3
Si4736	AM/FM/WB Receiver		✓	✓		✓									3x3
Si4737	AM/FM/WB Receiver with RDS		✓	✓		✓	✓					✓			3x3
Si4738	FM/WB Receiver		✓			✓									3x3
Si4739	FM/WB Receiver with RDS		✓			✓	✓					✓			3x3
Si4740 ¹	AM/FM Receiver		✓	✓										✓	4x4
Si4741 ¹	AM/FM Receiver with RDS		✓	✓			✓	✓				✓		✓	4x4
Si4742 ¹	AM/LW/SW/FM/WB Receiver		✓	✓	✓	✓								✓	4x4
Si4743 ¹	AM/LW/SW/FM/WB Receiver with RDS		✓	✓	✓	✓	✓	✓				✓		✓	4x4
Si4744 ¹	AM/LW/SW/FM Receiver		✓	✓	✓									✓	4x4
Si4745 ¹	AM/LW/SW/FM Receiver with RDS		✓	✓	✓		✓	✓				✓		✓	4x4
Si4749 ¹	High-Performance RDS Receiver						✓	✓						✓	4x4
Si4784	FM Receiver		✓									✓			3x3
Si4785	FM Receiver with RDS		✓				✓	2				✓			3x3
Notes:															
1. Si4706, Si4707, and Si474x are covered under NDA.															
2. High Performance RDS is available in Si4705/31/35/85-D50 and later.															

TABLE OF CONTENTS

1. Introduction	1
2. Description	8
2.1. Si47xx Baseboard	8
2.2. Si47xx Daughtercards	15
3. Recommended Hardware Setup	28
3.1. Hardware Setup for FM Transmitter Test	28
3.2. Hardware Setup for FM or Weather Band Receiver Test	29
3.3. Hardware Setup for AM Receiver Test	30
4. Getting Started	32
4.1. Software Installation	32
4.2. Board Initialization	33
4.3. Switching Functions	36
4.4. State Management	37
4.5. Disconnecting the EVB	39
5. FM Transmitter GUI	40
5.1. Configuring the Si47xx as an FM Transmitter Using Analog Audio Input	40
5.2. Configuring the Si47xx as an FM Transmitter Using Digital Audio with Analog Audio Source	41
5.3. Configuring the Si47xx as an FM Transmitter Using Digital Audio with SPDIF Digital Source	42
5.4. FM Transmitter Main Window	43
5.5. FM Transmitter Settings (Analog Mode) Property Window	45
5.6. FM Transmitter Settings (Digital Mode) Property Window	47
5.7. CODEC Settings	49
5.8. SPDIF Settings	50
5.9. FM Transmitter Receive Power Scan Window	51
5.10. FM Transmitter Radio Data Service (RDS)	52
5.11. FM Transmitter Register Map Window	60
6. FM Receiver GUI	61
6.1. Configuring the Si47xx as an FM Receiver	61
6.2. FM Receiver Main Window	62
6.3. FM Receiver Settings Property Window	64
6.4. CODEC and SPDIF Settings	73
6.5. FM Receiver RDS Window	74
6.6. FM Receiver RDS Settings	77
6.7. FM UI Settings	79
6.8. FM Receiver RSSI/SNR Graph Window	80
6.9. FM Receiver Register Map Window	81
6.10. FM Receiver Logging Tools	82
6.11. FM Receiver Configuration Helper	83
7. Weather Band GUI	90
7.1. WB Receiver Initialization	90
7.2. Weather Band Main Window	91

Si47xx-EVB

7.3. Weather Band Settings Property Window	92
7.4. Weather Band Receiver RSSI/SNR Graph Window	94
7.5. Weather Band Receiver Register Map Window	95
7.6. Weather Band Receiver SAME Event Data (Si4707 only)	96
8. AM Receiver GUI	97
8.1. AM Receiver Initialization	97
8.2. AM Receiver Main Window	98
8.3. AM Receiver Property Settings Window	100
8.4. AM Receiver RSSI/SNR Graph Window	105
8.5. AM Receiver Register Map Window	106
8.6. AM Receiver Logging Tools Info	107
8.7. AM Receiver Configuration Helper	108
9. Using the EVB with a 9 V Battery	109
10. Debugging Guidelines for Si47xx EVB	110
11. Bill of Materials	112
12. Schematics	124
12.1. Si47xx-EVB Baseboard Rev 1.6	124
12.2. Si471x/2x-EVB Daughtercard Rev 1.4	131
12.3. Si473x-EVB Daughtercard Rev. 1.4	133
12.4. Si474x-EVB Daughtercard Rev 1.3	135
12.5. Si4749-EVB Daughtercard Rev 1.1	137
12.6. Antenna Card Schematics	139
13. Layout	141
13.1. Si47xx-EVB Baseboard Rev 1.6	141
13.2. Si471x/2x-EVB Daughtercard Rev 1.4	144
13.3. Si473x-EVB Daughtercard Rev 1.4	147
13.4. Si474x-EVB Daughtercard Rev 1.3	150
13.5. Si4749-EVB Daughtercard Rev 1.1	152
13.6. Antenna Cards	155
Documentation Change List	163

This user's guide contains information related to only the Si47xx EVBs itemized in Table 2. Table 2 serves as a quick reference guide for the sections of interest for your EVB. Sections 1, 4, 9, and 10 of the document apply to all EVBs.

Table 2. Quick Reference Guide

Part	Description	Recommended HW Setup	GUI	Bill of Materials	Schematics	Layout
Si4704/05/06/84/85	Sections 2.1., 2.2.1., and 2.2.6.	Section 3.2.	Section 6.	Section 11. Tables 29 and 30	Sections 12.1., 12.2.	Sections 13.1., 13.2.
Si4707	Section 2.2.2., 2.2.5., 2.2.6.	Section 3.2.	Section 7.	Section 11., Tables 29 and 31	Section 12.1., 12.3.	Section 13.1., 13.3.
Si4710/11/12/13	Sections 2.1., 2.2.1., 2.2.6.	Section 3.1.	Section 5.	Section 11. Tables 29 and 30	Sections 12.1., 12.2.	Sections 13.1., 13.2.
Si4720/21	Sections 2.1., 2.2.1., 2.2.6.	Sections 3.1. and 3.2.	Sections 5. and 6.	Section 11. Tables 29 and 30	Sections 12.1., 12.2.	Sections 13.1., 13.2.
Si4730/31	Sections 2.1., 2.2.2., 2.2.5., 2.2.6	Sections 3.2. and 3.3.	Sections 6. and 8.	Section 11. Tables 29, 31, 34, 35, and 36	Sections 12.1., 12.3., 12.6.1., 12.6.2.	Sections 13.1., 13.3., 13.6.1., 13.6.2.
Si4734/35	Sections 2.1., 2.2.2., 2.2.5., 2.2.6.	Sections 3.2. and 3.3.	Sections 6. and 8.	Section 11. Tables 29 and 37	Sections 12.1., 12.3., 12.6.3.	Sections 13.1., 13.3., 13.6.3.
Si4736/37	Sections 2.1., 2.2.2., 2.2.5., 2.2.6.	Sections 3.2. and 3.3.	Sections 6., 7., and 8.	Section 11. Tables 29 and 37	Sections 12.1., 12.3., 12.6.3.	Sections 13.1., 13.3., 13.6.3.
Si4738/39	Sections 2.1., 2.2.2., 2.2.5., 2.2.6.	Sections 3.2. and 3.3.	Sections 6., and 7.	Section 11. Tables 29 and 37	Sections 12.1., 12.3., 12.6.3.	Sections 13.1., 13.3., 13.6.3.,
Si4740/41/42/43/44/45	Section 2.1., 2.2.3., 2.2.5., 2.2.6.	Sections 3.2. and 3.3.	Sections 7. and 8.	Section 11., Table 29, 32, 37	Sections 12.1., 12.4., 12.6.4.	Sections 13.1., 13.4., 13.6.4.
Si4749	Sections 2.1., 2.2.4., 2.2.6.	Section 3.2.	Section 6.	Section 11. Tables 29 and 33	Sections 12.1., 12.5.	Section 13.1., 13.5.

Si47xx-EVB

There are ten different EVB kits within the Si47xx family. Each kit ships with a standard set of components that are common to all kits and a unique set that depends on the EVB kit P/N. Standard set of components are:

- Customer welcome and evaluation letter
- EVB Characterization Report
- USB cable
- RCA cable
- 9 V battery
- Headphones
- Si47xx CD including:
 - Data sheet
 - Development application GUI rev 2.5.4 or later
 - User's guide
 - Quick start guide. The unique set of components for each EVB kit is defined in Table 3.

Table 3. Si47xx-EVB Kit Unique Contents

EVB Kit	Base Board	Daughtercard	Antenna Cards	Antennas	Adapters			
					BNC Male to RCA Female	SMA Male to BNC Female	SMA Female to BNC Male	SMA Male to SMA Male
Si4705-EVB	Si47xx Base board Rev1.3 or later	Si471x/2x Daughtercard Rev1.2 or later	—	—	Yes	No	No	No
Si4706-EVB	Si47xx Base board Rev1.3 or later	Si471x/2x Daughtercard Rev1.2 or later	—	—	Yes	No	No	No
Si4707-EVB	Si47xx Base board Rev1.3 or later	Si473x Daughtercard Rev1.2 or later	SAME antenna	Whip antenna	Yes	No	No	No
Si4713-EVB	Si47xx Base board Rev1.3 or later	Si471x/2x Daughtercard Rev1.2 or later	—	—	Yes	No	No	No
Si4721-EVB	Si47xx Base board Rev1.3 or later	Si471x/2x Daughtercard Rev1.2 or later	—	—	Yes	No	No	No
Si4731-EVB	Si47xx Base board Rev1.3 or later	Si473x Daughtercard Rev1.2 or later	4731 antenna kit (large ferrite, medium ferrite, air loop transformer)	Loop antenna	Yes	No	No	No

Table 3. Si47xx-EVB Kit Unique Contents (Continued)

EVB Kit	Base Board	Daughtercard	Antenna Cards	Antennas	Adapters			
					BNC Male to RCA Female	SMA Male to BNC Female	SMA Female to BNC Male	SMA Male to SMA Male
Si4735-EVB	Si47xx Base board Rev1.3 or later	Si473x Daughter Card Rev1.2 or later	SW antenna	Whip antenna	Yes	No	No	No
Si4737-EVB	Si47xx Base board Rev1.3 or later	Si473x Daughter Card Rev1.2 or later	WB antenna	Whip antenna	Yes	No	No	No
Si4743-EVB	Si47xx Base board Rev1.3 or later	Si474x Daughter Card Rev1.3 or later	Antenna Dummy	Whip antenna	Yes	Yes	No	Yes
Si4749-EVB	Si47xx Base board Rev1.3 or later	Si4749 Daughter Card Rev1.0 or later	—	Whip antenna	Yes	No	Yes	No

Si47xx-EVB

2. Description

Si47xx EVB consists of a baseboard, a daughtercard with the Si47xx part pre-mounted, and, if applicable, an antenna card. The baseboard is common and shared among all Si47xx EVBs. The following sections refer to both the images in the figures and the silkscreen on the Si47xx EVB. Please refer to both when using this guide.

2.1. Si47xx Baseboard

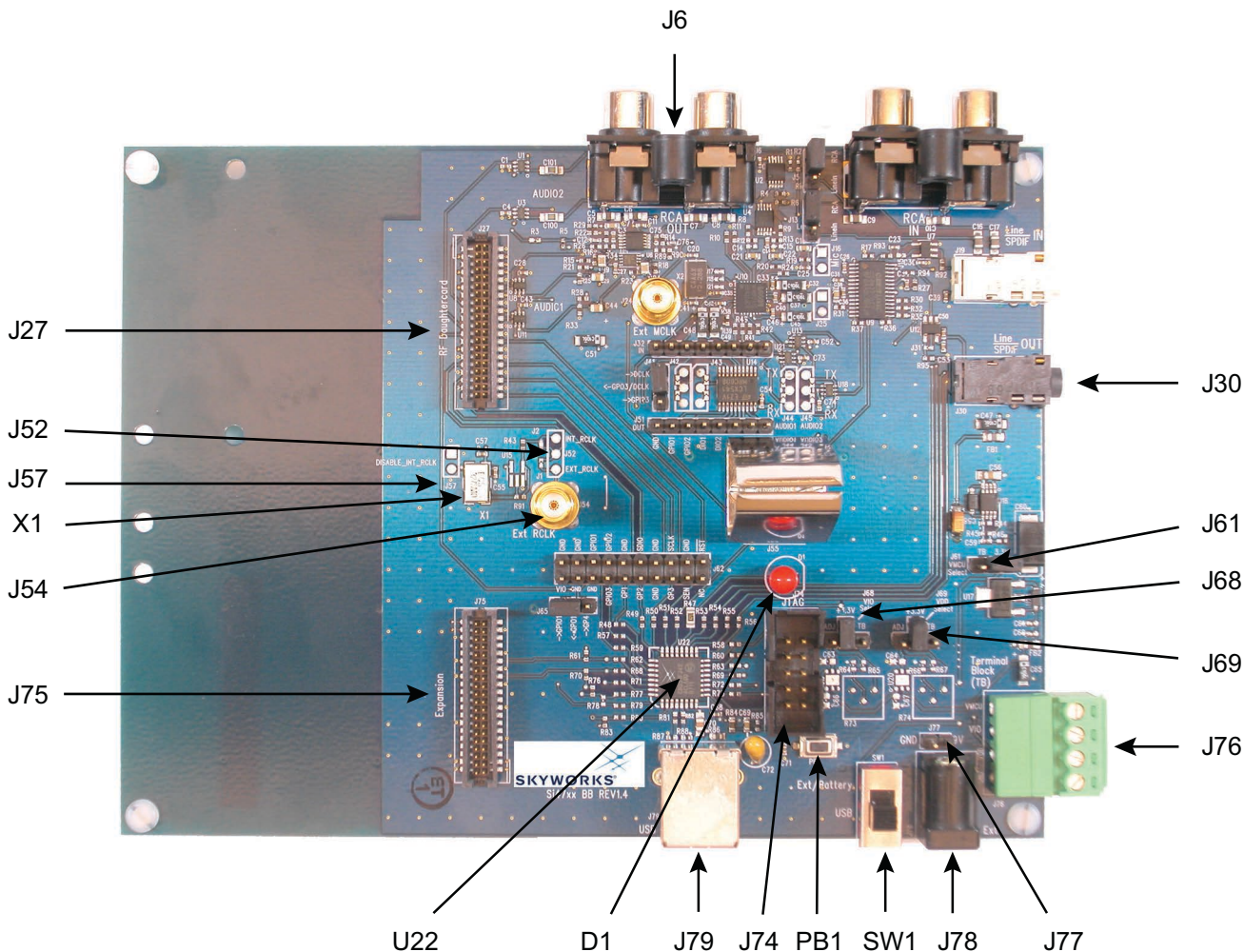

Figure 1. Baseboard Connectors, Jumpers, and Devices

Baseboard power connectors/devices:

- J79 USB connector (using USB power)
- J78 External power connector
- J77 Battery connector
- J76 Terminal block (TB) power connector
- SW1 Switch to select between USB power or Ext power
- J61 Jumper: Baseboard power select (3.3 V or TB)
- J68 Jumper: Si47xx VIO power select (3.3 V or adjustable voltage via R73 or TB)
- J69 Jumper: Si47xx VDD power select (3.3 V or adjustable voltage via R74 or TB)

Baseboard audio I/O connectors:

J6 RCA output

J30 Line output

Note: Line output will not be supported on new EVBs as of February 14, 2011.

Baseboard clock connectors/devices:

X1 32.768 kHz crystal oscillator

J52 Solder bump: select internal RCLK from oscillator

J54 Ext RCLK SMA connector input

J57 Jumper: Enable or Disable Int RCLK

Baseboard MCU connectors/devices:

U22 C8051F342 MCU

J79 USB connector to communicate with the MCU

J74 JTAG connector for the MCU

PB1 Push button to reset the MCU

D1 LED to confirm power supply to the MCU

Baseboard to Daughtercard connectors:

J27 Si47xx daughtercard connector

J75 Expansion card connector (reserved)

2.1.1. Power Supply Network

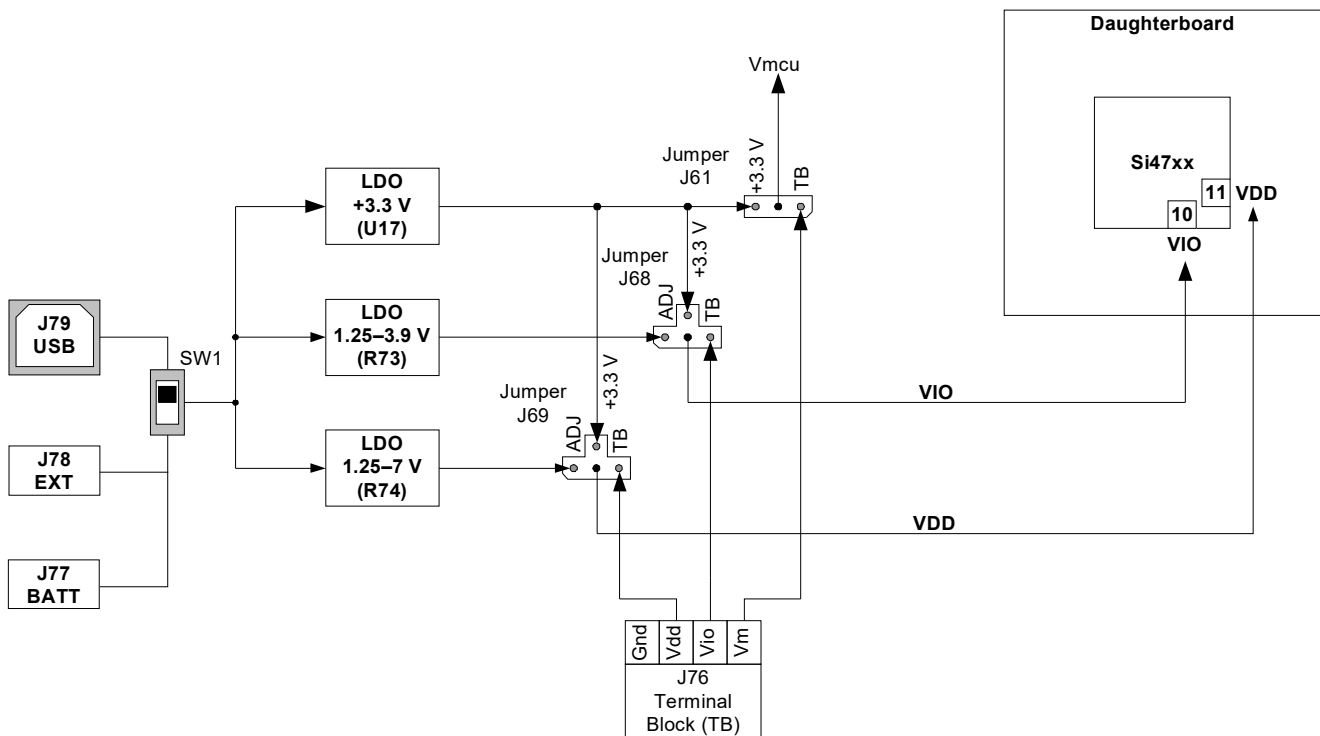

Figure 2. Power Supply Block Diagram

Si47xx-EVB

The Si47xx EVB can be powered using one of the following power supply options:

1. USB power supply via J79
2. External dc (Ext DC) power supply via power jack J78 or battery via J77
3. Three separate power supplies (Vdd, Vio, Vmcu) via terminal block J76

The EVB has three supply rails: Vdd, Vio, and Vmcu. Vdd and Vio are routed directly to the daughtercard to power the Vdd and Vio pins on the Si47xx chip, while Vmcu is used to power the baseboard.

The external dc power supply and battery should not be connected simultaneously. Refer to Section 9. "Using the EVB with a 9 V Battery," on page 109 for more information.

USB Power Supply & EXT DC Power Supply

Switch SW1 is used to select between the USB power supply and Ext dc power supply.

The USB power supply or the Ext dc power supply can be configured in one of the following two modes:

1. Fixed +3.3 V
2. Adjustable Vdd and Vio

Fixed +3.3 V

Only one LDO is used in this mode which outputs a +3.3 V supply to all three rails (Vdd, Vio, and Vmcu). The jumpers need to be set according to Figure 3 to use the EVB in this configuration. This is the default configuration on the EVB.

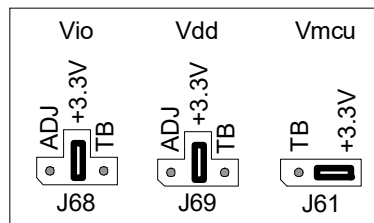

Figure 3. Default Fixed +3.3 V Jumpers Setting

Terminal Block Power Supply

If the terminal block supplies are used, then jumpers J61, J68, and J69 need to be set according to Figure 4. The user then needs to connect three different power supplies for Vdd, Vio, and Vmcu.

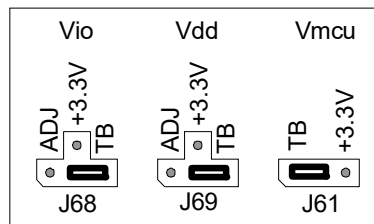

Figure 4. Terminal Block Jumpers Setting

2.1.2. Microcontroller

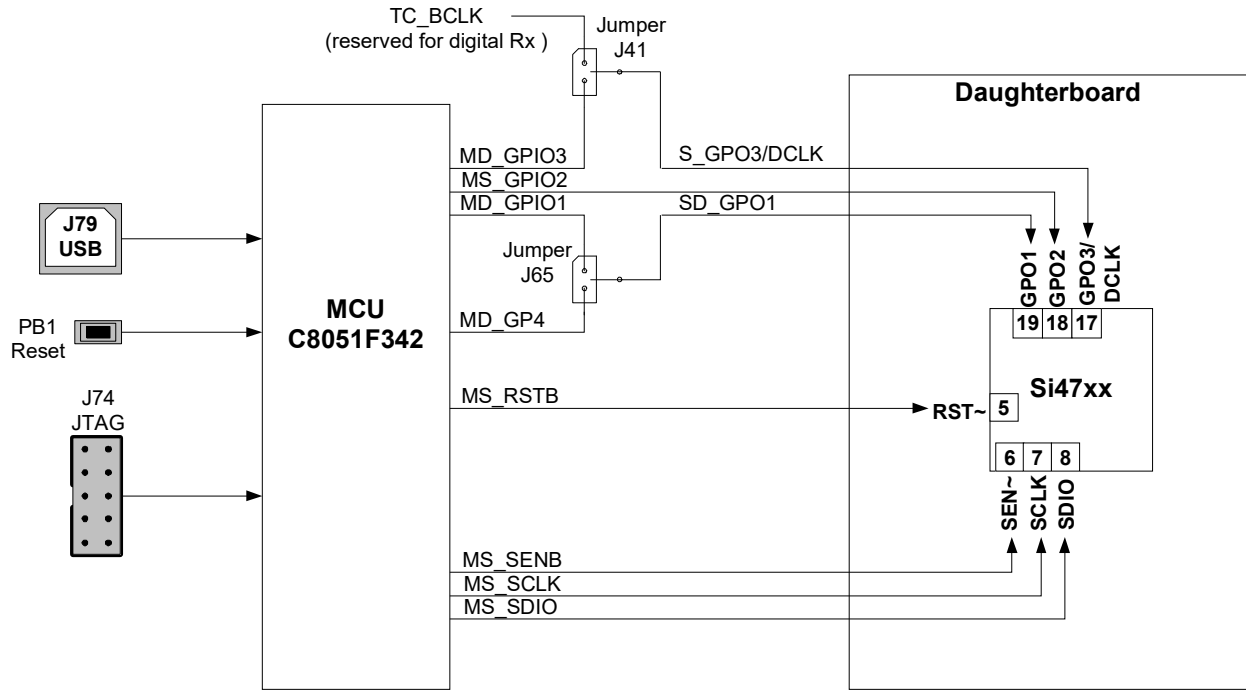

Figure 5. MCU Block Diagram

The Si47xx EVB uses a Skyworks' C8051F342 microcontroller to control the Si47xx and to provide USB connectivity from the host PC (via connector J79). The LED D1 illuminates to confirm that power is being properly supplied to the C8051F342 and firmware has loaded. Push-button PB1 manually resets the C8051F342. The JTAG connector J74 is used to program the C8051F342 at production time, and is not required thereafter.

Si47xx-EVB

2.1.3. Reference Clock

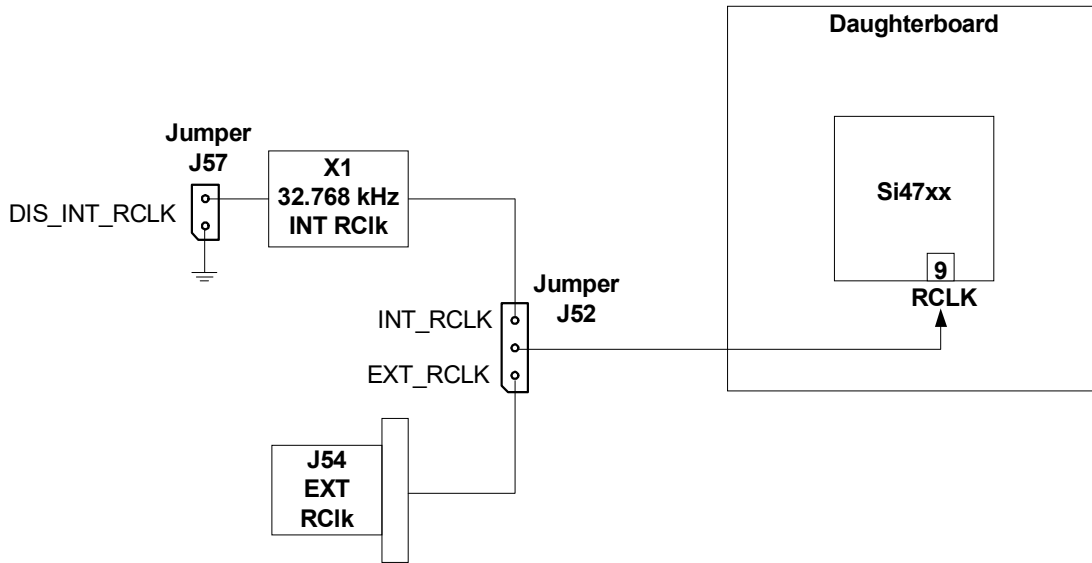
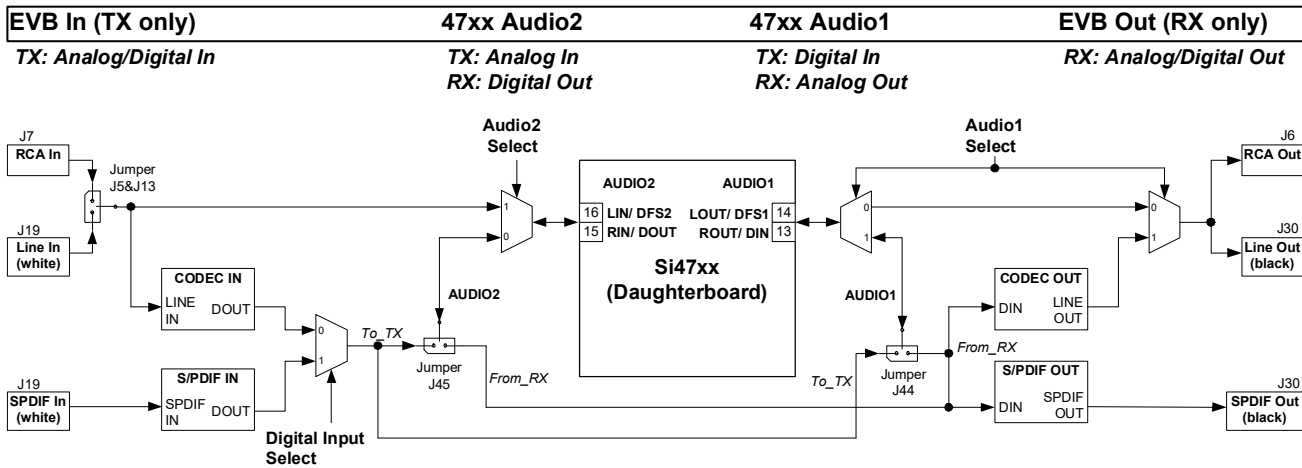

Figure 6. Reference Clock Block Diagram

The Si47xx accepts a 32.768 kHz reference clock at the RCLK pin. On the EVB, this clock is provided by a precision crystal oscillator. The user has the option of not using the onboard oscillator and bringing in the reference clock from an external source through SMA connector J54.

When the user chooses to provide an external RCLK, jumper J52 has to be set accordingly. The user has the option to turn off the onboard crystal oscillator by installing jumper J57.

2.1.4. Audio I/O



Note: Jumper J44 and J45 are automatically configured in EVB Rev 1.3.

Figure 7. Audio I/O Block Diagram

The EVB supports three different kinds of configurations for the FM transmitter:

- Analog In to Analog In
- Analog In to Digital In
- Digital In to Digital In

Analog In to Analog In: This configuration provides a way for the user to evaluate the analog audio input for FM transmission.

The input to the EVB is an analog audio provided via the RCA input connector J7 or LINE In connector J19 (white). Jumpers J5 and J13 are set to RCA input by default. The user has to change this jumper accordingly if LINE In is being used. Then the analog audio input is routed directly through a switch to the Si47xx Rin/Lin inputs pin 15 and 16 (Audio2).

Analog In to Digital In: This configuration provides a way for the user to evaluate the Si47xx digital audio input for FM transmission using an analog audio input.

The input to the EVB is an analog audio provided via the RCA input connector J7 or LINE In connector J19 (white). Jumpers J5 and J13 are set to RCA input by default. The user has to change this jumper accordingly if LINE In is being used. Then the analog audio input is converted by CODEC U10 to a serial audio digital data before it is routed to the Si47xx digital audio input DIO and DFS pin 13 and 14 (Audio1). The DCLK input is routed to the GPO3/DCLK pin 17. Make sure that jumper J41 is set to DCLK to ensure proper operation.

Digital In to Digital In: This configuration provides a way for the user to evaluate the Si47xx digital audio input for FM transmission using S/PDIF digital audio commonly found in sound cards.

The input to the EVB is a digital S/PDIF data provided via the S/PDIF In connector J19 (white). The digital S/PDIF input is converted by S/PDIF Translator U9 to a serial audio digital data before it is routed to the Si47xx digital audio input DIO and DFS pin 13 and 14 (Audio1). The DCLK input is routed to the GPO3/DCLK pin 17. Make sure that jumper J41 is set to DCLK to ensure proper operation.

Note: Digital in through J19 will not be supported on new EVBs as of February 14, 2011.

The EVB supports three different kinds of configurations for the FM receiver:

- Analog Out to Analog Out
- Digital Out to Digital and Analog Out
- Dual Output (Digital and Analog Out)

Analog Out to Analog Out: This configuration provides a way for the user to evaluate the analog audio output for receiver operation. The output of the Si47xx is routed to RCA output connector J6 and Line output connector J30.

Digital Out to Digital and Analog Out: This configuration provides a way for the user to evaluate the digital audio output for FM and AM receive using either S/PDIF digital audio or analog audio through the onboard CODEC. The Si47xx digital audio out is routed through the S/PDIF translator μ 9 to S/PDIF output connector J30 and routed through the CODEC to RCA output connector J6 and line output connector J30.

Note: Digital output through J30 will not be supported on new EVBs as of February 14, 2011.

Dual Output (Digital and Analog Out): This configuration provides a way for the user to evaluate the analog audio out and digital audio using S/PDIF digital audio for FM and AM. The analog output of the Si47xx is routed to RCA output connector J6 and line output connector J30 and the digital audio out is routed through the S/PDIF translator to S/PDIF output connector J30.

Note: Digital output through J30 will not be supported on new EVBs as of February 14, 2011.

Si47xx-EVB

IMPORTANT: Jumper Settings

Because of the many possibilities available to configure the EVB, ensure that these four jumpers are set accordingly:

1. J41: GPO3/DCLK setting
2. J44: TX/RX setting for Audio1 I/O (automatically set by the GUI for baseboard 1.3 and later)
3. J45: TX/RX setting for Audio2 I/O (automatically set by the GUI for baseboard 1.3 and later)
4. J5, J13: Analog Audio Source, RCA or Line In

J41: GPO3/DCLK Setting

Upper—DCLK digital audio clock

Lower—GPO3 digital control signal

For configuring the Si47xx digital audio input, make sure that the jumper is set in the Upper position so that the DCLK signal will be routed to the Si47xx.

J44: TX/RX Setting for Audio1 I/O (automatically set by the GUI for baseboard 1.3 and later)

Upper—Audio1 is set to FM transmit (pin 13 and 14 will be the digital audio input).

Lower—Audio1 is set for FM receive (pin 13 and 14 will be analog/digital audio output).

J45: TX/RX Setting for Audio2 I/O (automatically set by the GUI for baseboard 1.3 and later)

Upper—Audio2 is set to FM transmit (pin 15 and 16 will be the analog/digital audio input).

Lower—Audio2 is set for FM receive (pin 15 and 16 will be the digital audio output).

J5, J13: Analog Audio Source, RCA or Line In

Upper—RCA inputs are used for analog audio source.

Lower—Line inputs are used for analog audio source.

2.2. Si47xx Daughtercards

2.2.1. Si471x/2x Daughtercard

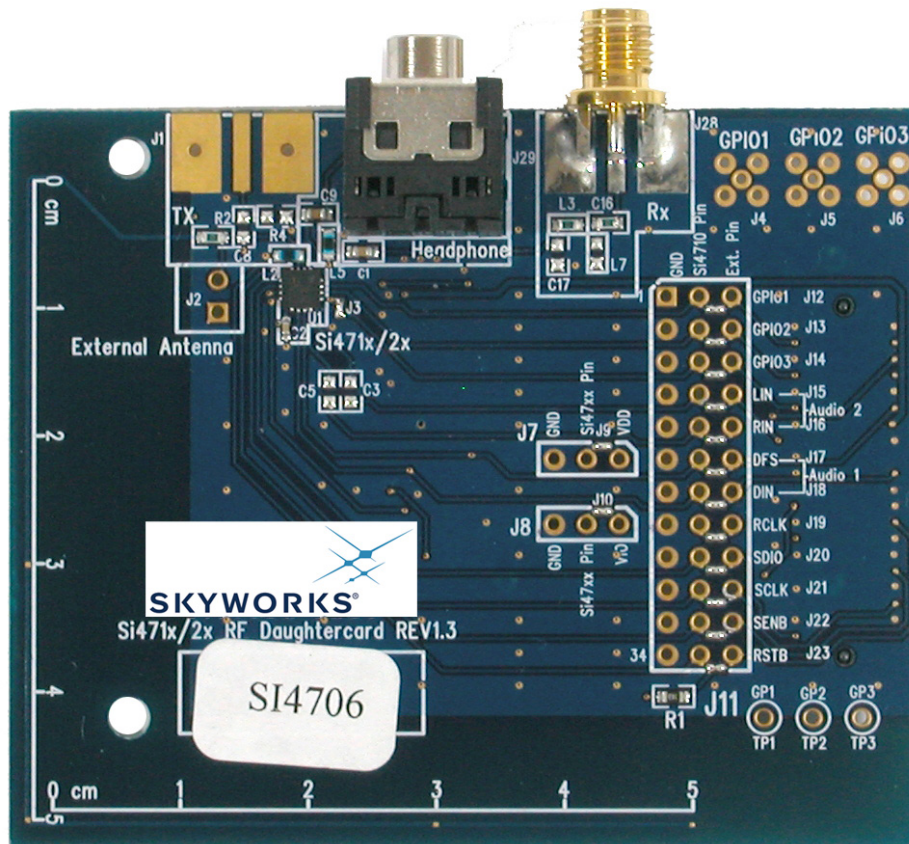

Figure 8. Si471x/2x Daughtercard Connectors and Devices

Daughtercard Connectors and Components:

- U1 Si472x FM Transceiver or Si470x FM Receiver or Si471x FM Transmitter
- L2 Tuning Inductor
- R2 0 Ω resistor to connect FM TX output to 10 cm trace built-in antenna
- C8 2 pF capacitor to connect FM TX output to J1 SMA connector
- R4 50 Ω termination resistor
- J1 SMA connector for FM transmitter output or FM receiver input for embedded antenna
- J2 Header for putting external antenna for FM transmitter or embedded antenna for FM receiver
- J28 SMA connector for FM receiver input
- J29 Headphone jack for FM receiver

Si47xx-EVB

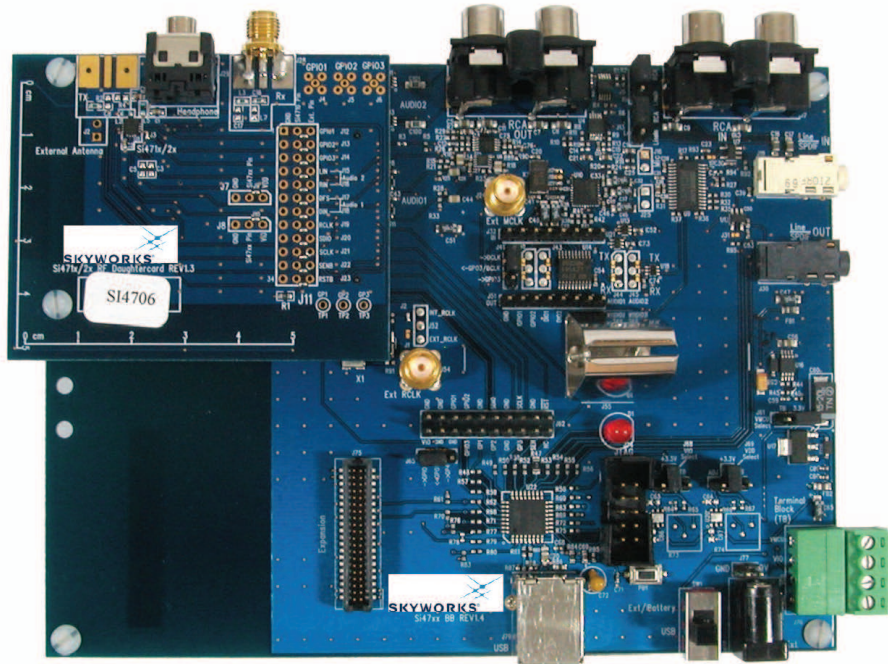

Figure 9. Fully Assembled Si471x/2x EVB

Si470x/1x/2x EVBs use Si471x/2x daughtercard with different population options depending on the individual Si470x/1x/2x part. Please refer to individual Bill of Materials for each board.

2.2.2. Si473x Daughtercard

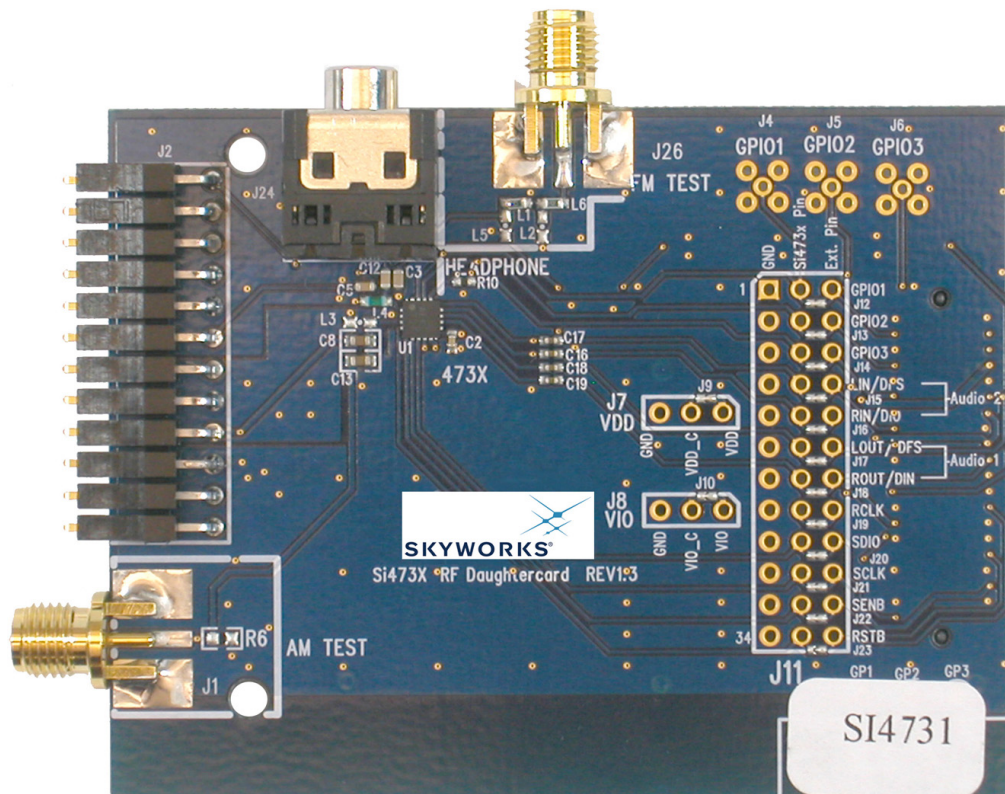

Figure 10. Si473x Daughtercard Connectors and Devices

Daughtercard connectors and components:

- J1 SMA connector for AM test circuit (does not apply to Si4707-EVB)
- J2 Header for antenna interface connection
- J24 Headphone jack
- J26 SMA connector for FM test circuit
- L4 270 nH inductor for FM input
- U1 Si473x AM/FM/SW Weather Band Receiver chip (or Si4707 WB/Same receiver for Si4707-EVB only)
- C2 Vdd bypass capacitor
- C3 FM test circuit ac coupling capacitor
- C8 AM input ac coupling capacitor
- C12 FM input ac coupling capacitor
- C13 AM test circuit ac coupling capacitor

Si47xx-EVB

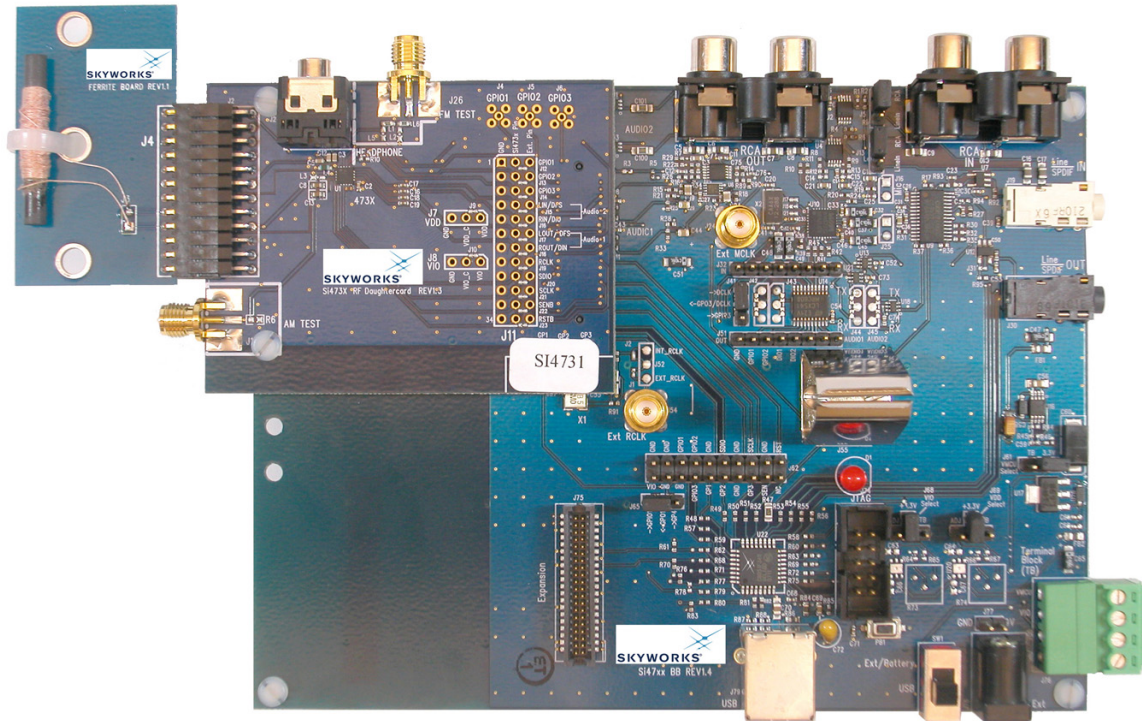

Figure 11. Fully Assembled Si473x-EVB with Ferrite Antenna Card

The Si473x/07 EVBs use Si473x daughtercard with different population options depending on the individual Si473x/07 part. Please refer to individual Bill of Materials for each card.

Table 4 shows the antenna and audio connections for the Si47xx EVBs.

2.2.3. Si474x Daughtercard

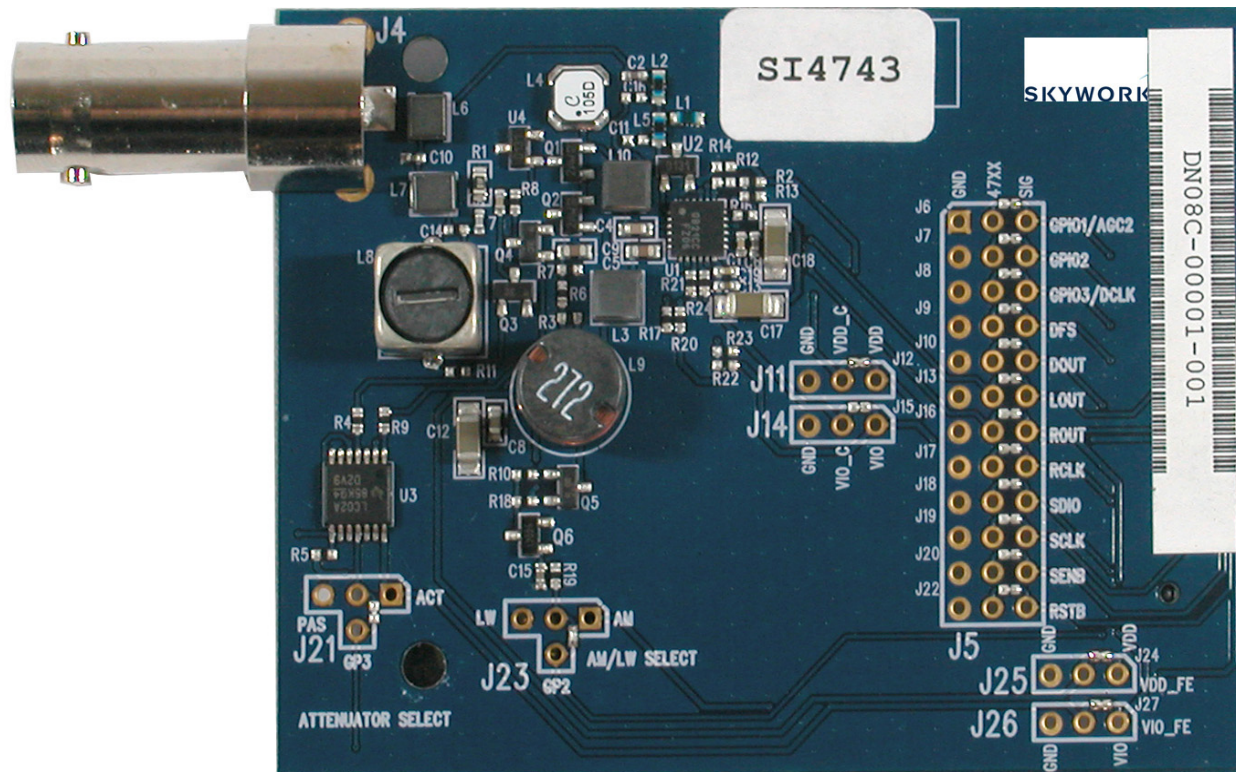

Figure 12. Si474x Daughtercard Connectors and Devices

Daughtercard connectors and components:

J4	BNC connector for antenna connection
C6, C1, C18	Vdd bypass capacitor
C2	FM matching component
L1, L5	FM matching component
Q1–2	Cascode amplifier for AM front-end boost circuit.
U1	Si4740/41/42/43 AM/FM Receiver chip

The daughtercard implements the Si4740/41/42/43 AM/FM RDS receive solution.

The Si474x daughtercard also has a cascode amplifier circuit made up of two transistors to provide gain boost for AM front-end. The on-chip De-Q resistors will then be used to adjust the overall circuit gain. In cases where the AM reception is too strong, the front-end attenuators can be engaged by using GPIO1 as the control signal.

Si47xx-EVB

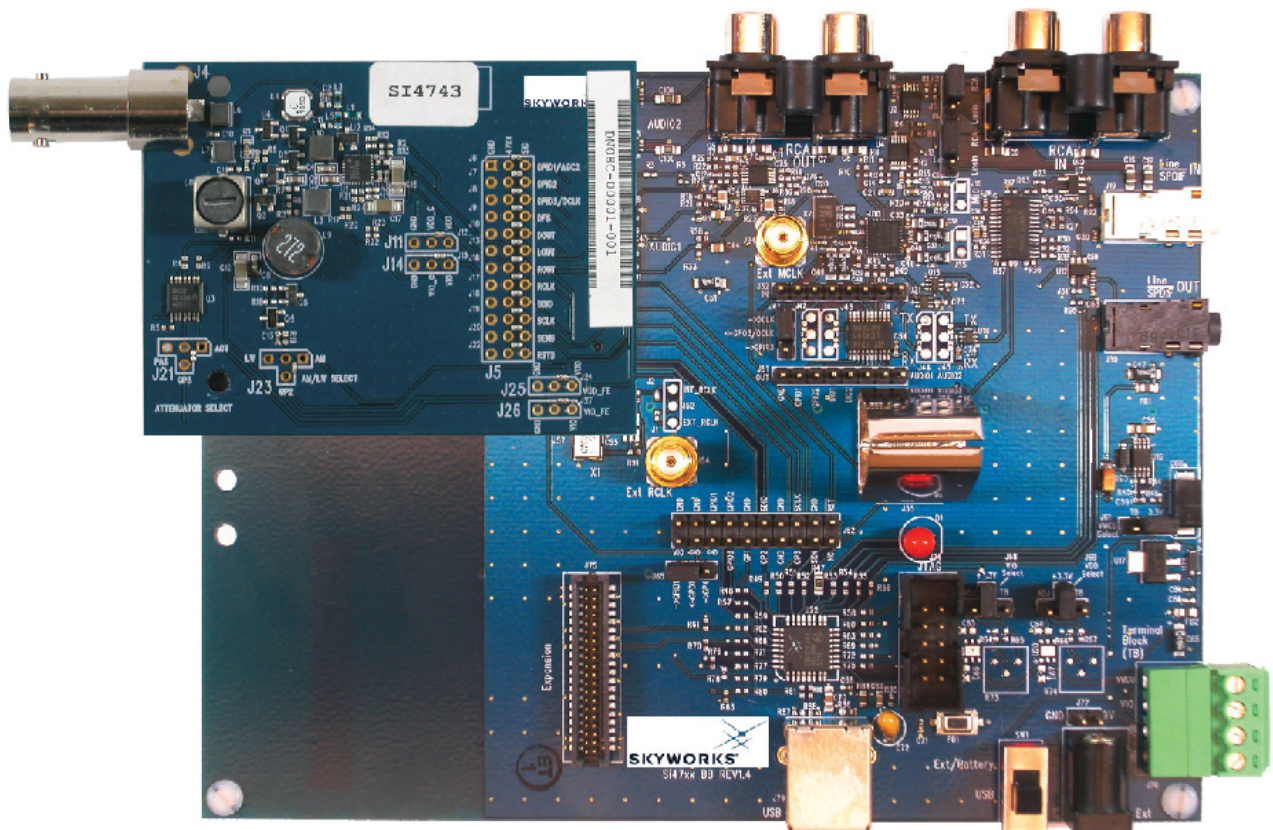

Figure 13. Fully Assembled Si474x-EVB

2.2.4. Si4749 Daughtercard

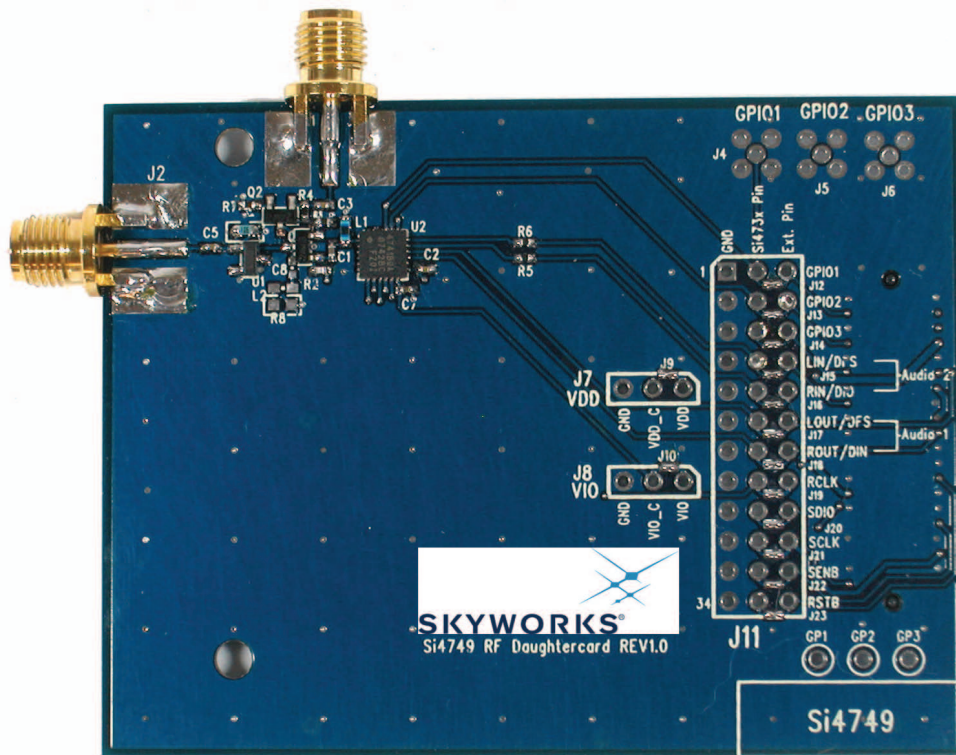

Figure 14. Si4749 Daughtercard Connectors and Devices

Daughtercard connectors and components:

- J1 SMA connector for pass-thru FM connection
- J2 SMA connector for FM antenna connection
- C2 Vdd bypass capacitor
- L1 FM matching component
- U2 Si4749 RDS Receiver

The daughtercard implements the Si4749 RDS receive solution. The SMA connector, J2, allows the user to attach a whip antenna for FM reception or a signal generator for FM test circuit. A pass-thru connection, J1, is also present to provide the FM signal to other FM receivers if necessary.

Si47xx-EVB

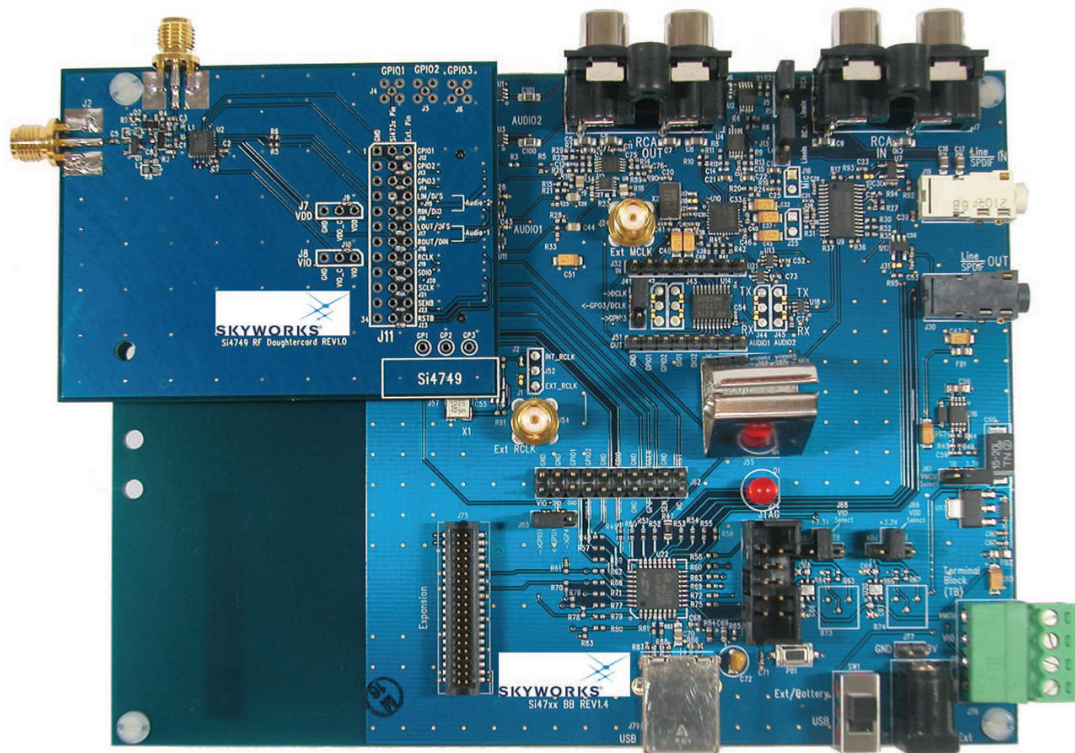

Figure 15. Fully Assembled Si4749-EVB

2.2.5. Antenna Interfaces

2.2.5.1. AM Antenna Interface

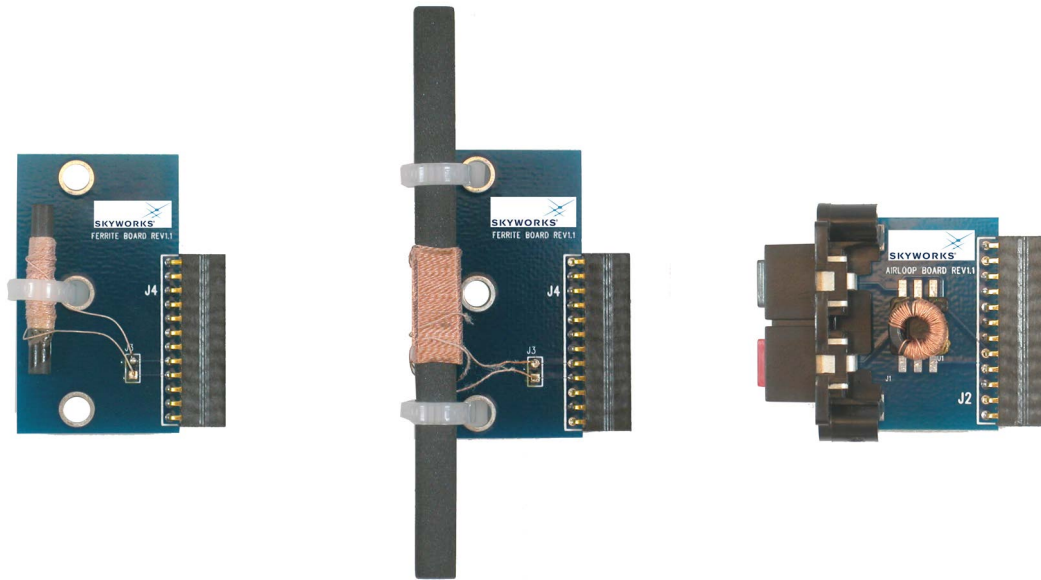

Figure 16. Antenna Board Options—SL4X30MW100T (Medium Ferrite), SL5X7X100MW70T (Large Ferrite), and SL9X5X4MWTF Airloop

The user has the flexibility of choosing one of the two available antenna options. The user can either decide to use the airloop antenna or the ferrite loop stick antenna.

Si47xx-EVB

2.2.5.2. SW and Weather Band Antenna Interfaces

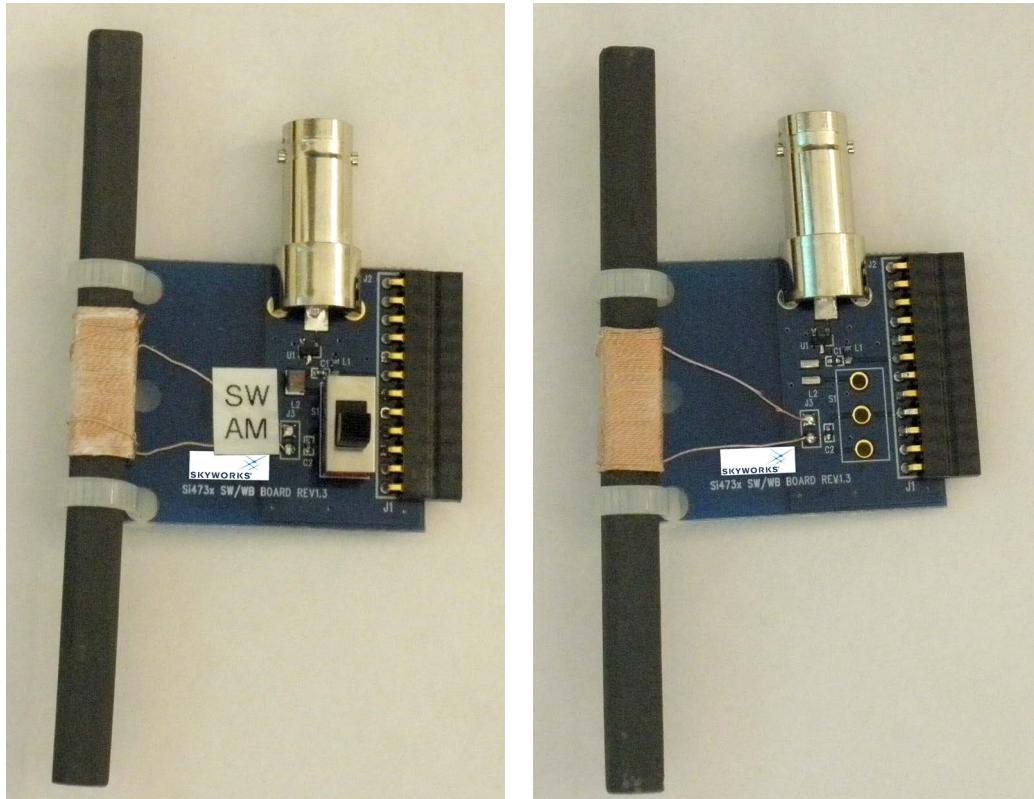

Figure 17. SW/WB Antenna Card (SW Population) and (WB Population)

The BNC connector, J2, will be used to connect a whip antenna for shortwave, FM, and weather band reception. For SW reception, switch S1 must be in the SW position. The ferrite bar is used for AM reception, and the switch S1 must be in the AM position for AM reception.

When using the WB Antenna Card, WB reception is through the whip antenna. For a better listening experience, plug the headphones to J30 rather than J24.

Note: LW not supported with SW/WB Antenna Card.

2.2.5.3. Si474x Antenna Dummy Card



Figure 18. Si474x Antenna Dummy Card

Table 4. Si47xx Antenna Connections

EVB Kit Name	Receiver	AM Antenna Options	AM Connections	FM Antenna Options	FM Connections	SW Antenna Options	SW Connections	WB Antenna Options	WB Connections
Si4705-X-EVB	Si4705	None	None	Head-phone	J29		None	None	
				Trace	J2				
Si4706-X-EVB	Si4706	None	None	Head-phone	J29		None	None	
				Trace	J2				
Si4707-B-EVB	Si4707	None	None	None			None	Headphone	J24
								Whip/SAME Antenna Card	J2
Si4713-B-EVB	Si4713	None	None	Trace	J2		None		
Si4721-B-EVB	Si4721	None	None	Head-phone	J29		None		
				Trace	J2				
Si4731-X-EVB	Si4731	SL5X7X100M W70T Ferrite / Large Ferrite	J2	Head-phone	J24		None		
		SL4X30MW1 10T Ferrite / Medium Ferrite	J2						
		SL9X5X4MW TF Autotransformer / Air loop	J2						
Si4735-X-EVB	Si4735	SL5X7X100M W70T Ferrite / SW Antenna card	J2	Head-phone	J24	Whip/SW Antenna Card	J2		
				Whip/SW Antenna Card	J2	For SW reception, set the S1 switch to SW position. LW is not supported by the SW antenna card.			
Si4737-X-EVB	Si4737	SL5X7X100M W70T Ferrite / WB Antenna card	J2	Head-phone	J24		None	Headphone	J24

Si47xx-EVB

Table 4. Si47xx Antenna Connections (Continued)

EVB Kit Name	Receiver	AM Antenna Options	AM Connections	FM Antenna Options	FM Connections	SW Antenna Options	SW Connections	WB Antenna Options	WB Connections
				Whip/WB Antenna Card	J2			Whip/WB Antenna Card. For WB reception, set the S1 switch to WB position	J2
Si4743-C-EVB	Si4743	Whip / Si474x Antenna Dummy card	J4	Whip	J4		Whip		
Si4749-C-EVB	Si4749	None	None	Whip	J2		None		

Table 5. Si47xx Audio Connections

EVB Kit Name	Receiver	Audio Out Options	Audio Out Connections	Audio In Options	Audio Connections
Si4705-X-EVB	Si4705	Headphone	J29	None	None
		Unity Gain Buffer / RCA	J6 (Baseboard)		
Si4706-X-EVB	Si4706	Headphone	J29	None	None
		Unity Gain Buffer / RCA	J6 (Baseboard)		
Si4707-B-EVB	Si4707	Headphone	J29	None	None
		Unity Gain Buffer / RCA	J6 (Baseboard)		
Si4713-B-EVB	Si4713	None	None	Unity Gain Buffer / RCA	J7 (Baseboard)
Si4721-B-EVB	Si4721	Headphone	J29	Unity Gain Buffer / RCA	J7 (Baseboard)
		Unity Gain Buffer / RCA	J6 (Baseboard)		
Si4731-X-EVB	Si4731	Headphone	J24	None	None
		Unity Gain Buffer / RCA	J6 (Baseboard)		
Si4735-X-EVB	Si4735	Headphone	J24	None	None
		Unity Gain Buffer / RCA	J6 (Baseboard)		
Si4737-X-EVB	Si4737	Headphone	J24	None	None
		Unity Gain Buffer / RCA	J6 (Baseboard)		
Si4743-C-EVB	Si4743	Unity Gain Buffer / RCA	J6 (Baseboard)	None	None
Si4749-C-EVB	Si4749	None	None	None	None

2.2.6. Test Circuit Interfaces

Table 6 shows the test circuit interface connections for Si47xx EVBs.

Table 6. Si47xx Test Circuit Connections

EVb Kit Name	Receiver	AM/SW/LW Test Options	AM/SW/LW Connections	FM Test Options	FM Connections	Audio Out Test Options	Audio Out Connections	Audio In Test Options	Audio In Connections
Si4705-X-EVB	Si4705	None	None	FMI / SMA	J28 through C1. Remove C9 for best sensitivity	Unity Gain Buffer / RCA	J6 (Baseboard)	None	None
				LPI / SMA	J1				
Si4706-X-EVB	Si4706	None	None	FMI / SMA	J28 through C1. Remove C9 for best sensitivity	Unity Gain Buffer / RCA	J6 (Baseboard)	None	None
				LPI / SMA	J1				
Si4707-B-EVB	Si4707	None	None	FMI / SMA	J26	Unity Gain Buffer / RCA	J6 (Baseboard)	None	None
Si4713-B-EVB*	Si4713	None	None	LPI / SMA	J1	None	None	Unity Gain Buffer / RCA	J7
Si4721-B-EVB	Si4721	None	None	FMI / SMA	J28 through C1. Remove C9 for best sensitivity	Unity Gain Buffer / RCA	J6 (Baseboard)	Unity Gain Buffer / RCA	J7
				LPI / SMA	J1				
Si4731-X-EVB	Si4731	AMI / SMA	J1 through C13, remove C8 for best sensitivity	FMI / SMA	J26 through C3. Remove C12 for best sensitivity	Unity Gain Buffer / RCA	J6 (Baseboard)	None	None
Si4735-X-EVB	Si4735	AMI / SMA	J1 through C13, remove C8 for best sensitivity	FMI / SMA	J26 through C3. Remove C12 for best sensitivity	Unity Gain Buffer / RCA	J6 (Baseboard)	None	None
Si4737-X-EVB	Si4737	AMI / SMA	J1 through C13, remove C8 for best sensitivity	FMI / SMA	J26 through C3. Remove C12 for best sensitivity	Unity Gain Buffer / RCA	J6 (Baseboard)	None	None
Si4743-C-EVB	Si4743	AMI / BNC	J4	FMI / BNC	J4	Unity Gain Buffer / RCA	J6 (Baseboard)	None	None
Si4749-C-EVB	Si4749	None	None	FMI / SMA	J2	None	None	None	None

***Note:** The FM RF output will be available through the SMA connector J1. Refer to Table 7.

Table 7. FM Band Attenuation Factors

Frequency (MHz)	Attenuation (dB)
76	32.13
88	30.91
98	30
108	29.2

Si47xx-EVB

3. Recommended Hardware Setup

The Si47xx-EVB can be configured for FM transmit, FM receive, WB receive, or AM/SW/LW receive. The following is a description of how to correctly configure the device for either mode of operation.

3.1. Hardware Setup for FM Transmitter Test

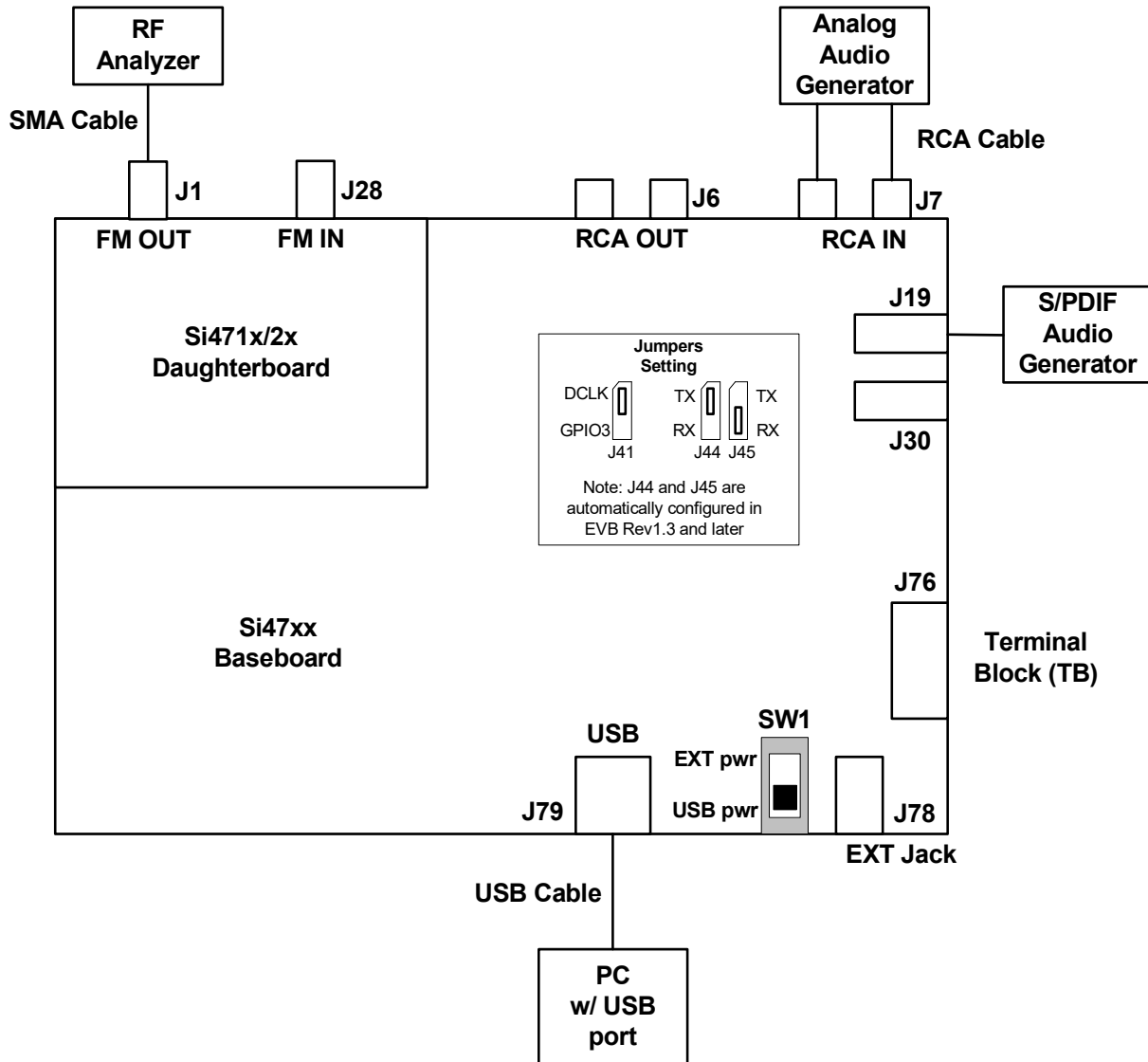

Figure 19. Hardware Setup for FM Transmitter Test

Instructions for Si471x/2x daughtercards:

1. Connect the USB cable from PC to the EVB USB connector J79. The USB connection will serve as a dual purpose: supplying the power to the EVB and controlling the EVB.
2. Connect an analog audio generator to the RCA input connector J7 using an RCA cable or connect an SPDIF digital audio generator to connector J19 using an SPDIF cable.
3. Connect an RF analyzer from the FM output SMA connector J1 using an SMA cable.
4. J19 and J30 S/PDIF connections are no longer supported on EVBs as of February 14, 2011.

3.2. Hardware Setup for FM or Weather Band Receiver Test

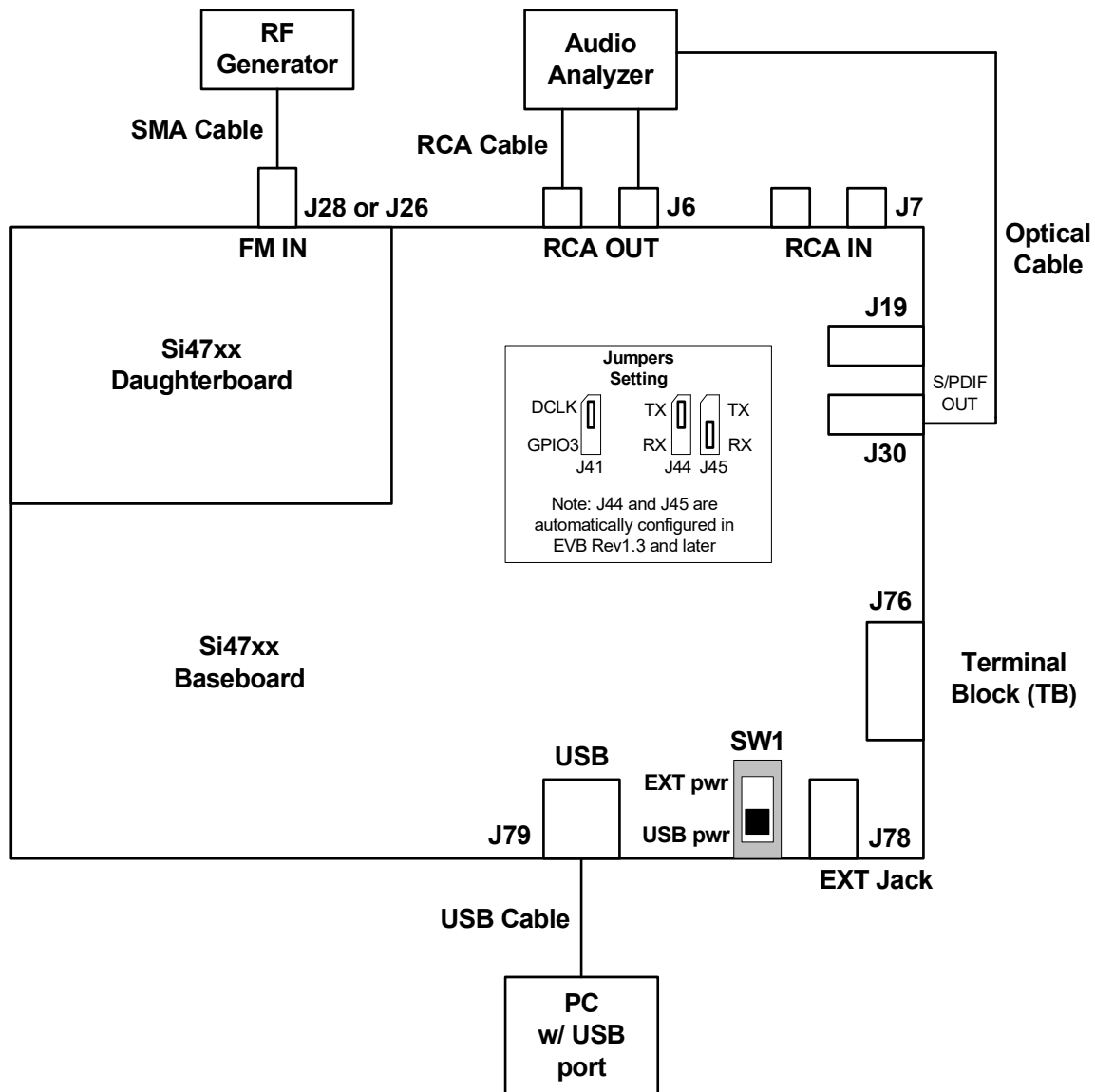

Figure 20. Hardware Setup for FM/Weather Band Receiver Test

Instructions for Si4704/05/06/2x/3x/8x daughtercards:

1. Connect the USB cable from PC to the EVB USB connector J79. The USB connection will serve as a dual purpose, supplying the power to the EVB and controlling the EVB.
2. Connect an audio analyzer from the RCA output connector J6 using an RCA cable.
3. Connect an RF generator to the FM input SMA connector J28 or J26 using an SMA cable.
4. Connect an audio analyzer to the S/PDIF output connector, J30, using an optical cable.
5. **To avoid possible sources of interference, please remove C9 or C12 (depending on the daughtercard). This will disconnect the headphone circuit from the test circuit.**
6. J19 and J30 S/PDIF connections are no longer supported on EVBs as of February 14, 2011.

Si47xx-EVB

3.3. Hardware Setup for AM Receiver Test

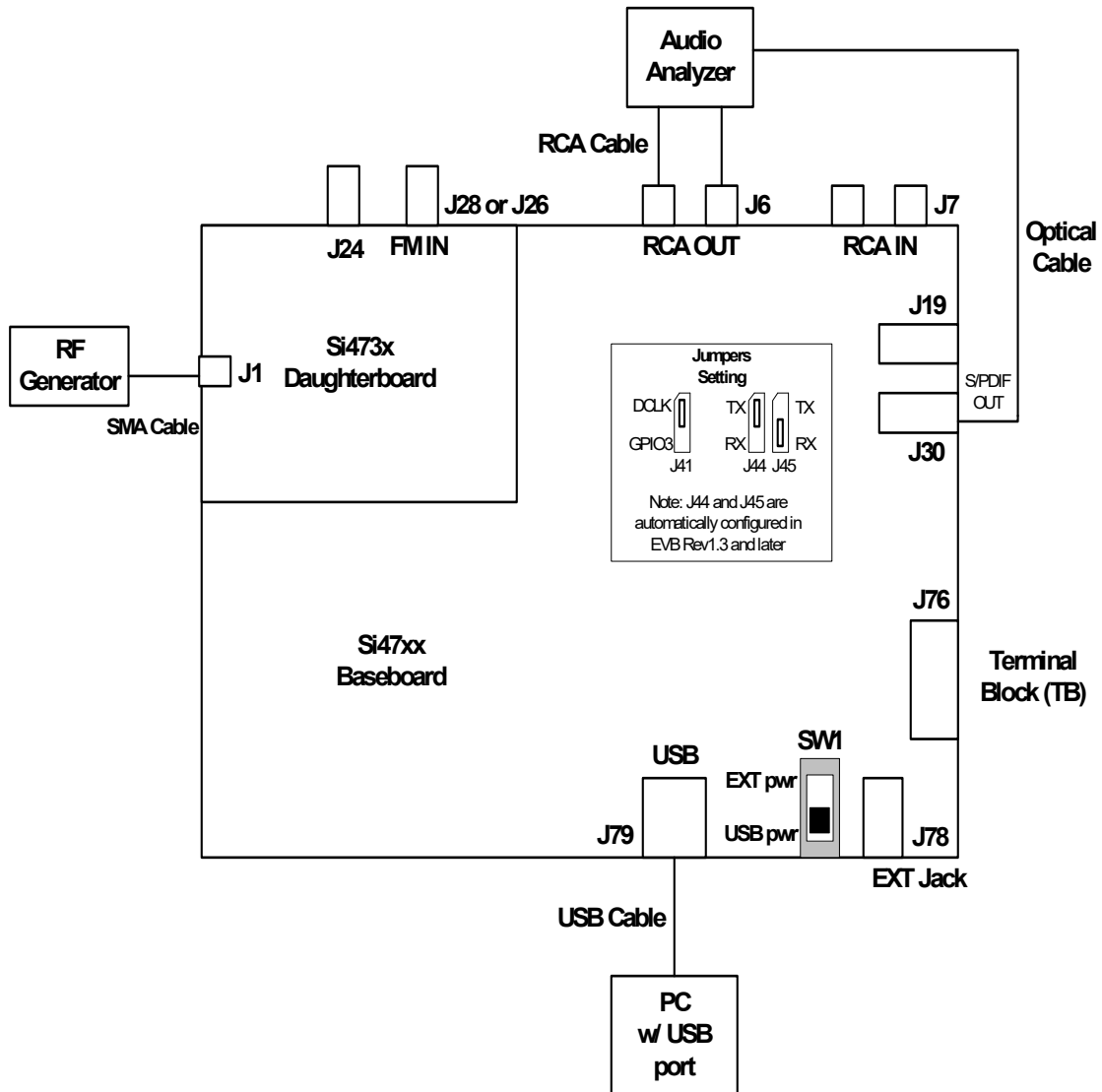

Figure 21. Hardware Setup for AM Receiver Test (Si473x)

Instructions for Si473x daughtercards.

1. Connect the USB cable from PC to the EVB USB connector, J79. The USB connection will not only allow controlling of the EVB, but will also provide power to the EVB.
2. Connect either the ferrite antenna or the airloop antenna board. The user also has the option of using the AM test input for characterization by connecting the AM test input connector J1 to an RF generator source.
3. Connect an audio analyzer to the RCA output (connector J6) using an RCA cable for the analog audio output.
4. Connect an audio analyzer to the S/PDIF output (connector J30) using an optical cable.
5. Or, connect the headphone output to J24 on the daughtercard.
6. J19 and J30 S/PDIF connections are no longer supported on EVBs as of February 14, 2011.

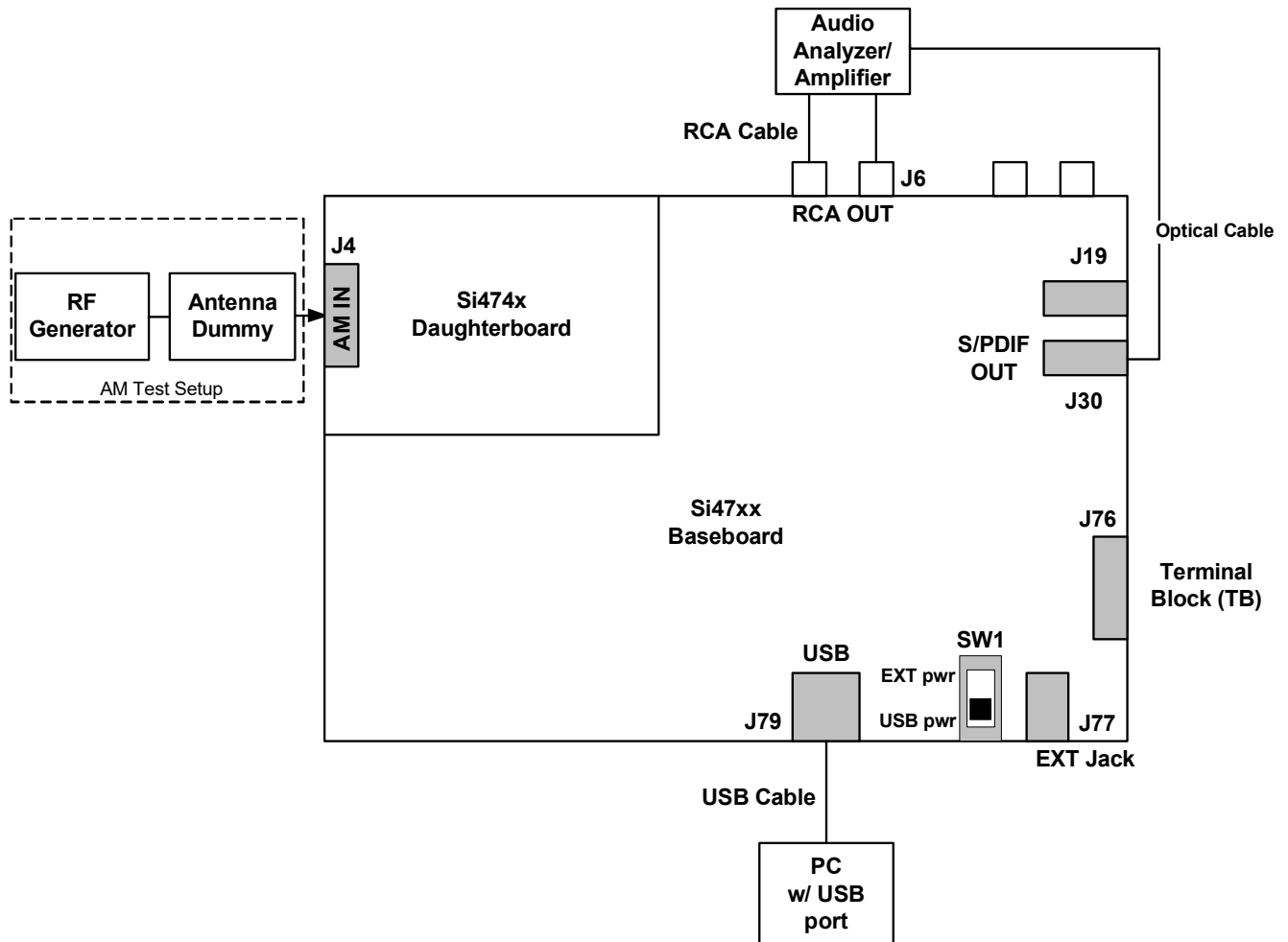

Figure 22. Hardware Setup for AM Receiver Test (Si474x)

Instructions for Si474x daughtercards:

1. Connect the USB cable from PC to the EVB USB connector, J79. The USB connection will serve two purposes: supplying the power to the EVB and controlling the EVB.
2. Connect a whip antenna to J4. The user has the option of using the AM test input for characterization by connecting the AM test input connector J4 to an RF generator source through an antenna dummy.
3. Connect an audio analyzer to the RCA output (connector J6) using an RCA cable for the analog audio output.
4. Connect an audio analyzer to the S/PDIF output (connector J30) using an optical cable.
5. J19 and J30 S/PDIF connections are no longer supported on EVBs as of February 14, 2011.

Si47xx-EVB

4. Getting Started

4.1. Software Installation

The Si47xx Windows GUI (graphical user interface) software is designed for use with the Si47xx evaluation board (EVB). The GUI software revision number is available under Help→About.

The GUI software development program uses a host machine USB port to communicate with the Si47xx EVB and is tested for use with Windows XP, Windows 2000, and Windows 7.

To install, insert the Skyworks Si47xx CD into the host machine CD drive and launch Windows Explorer. Open the CD to explore the contents in a window like the one shown in Figure 23.

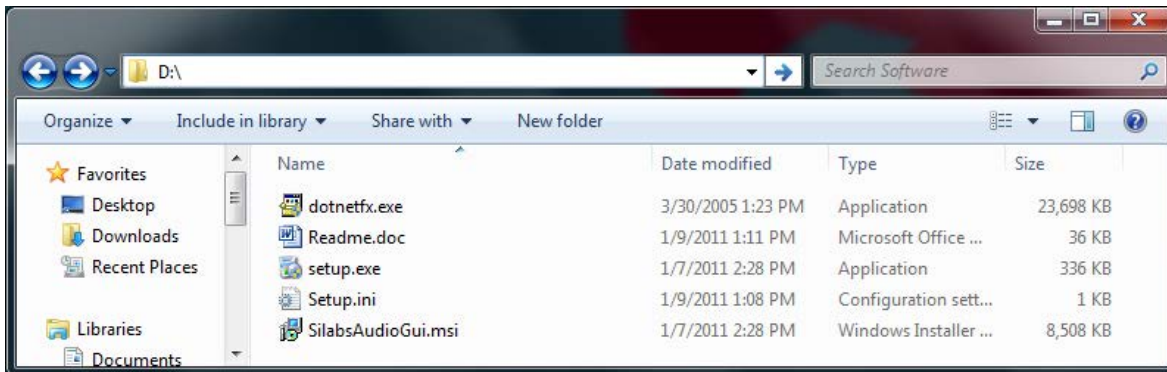

Figure 23. Installation and Setup Screen

Important: Open and read the Readme.doc file at this point. It may contain information that is not captured here, and which could be very important to the functionality of the EVB or software.

Run the Setup.Exe and follow the instructions on the screen.

Note: If you get this Error message: "This setup requires the .NET Framework version 4.0," then you should install the .NET Framework that is provided on the CD and re-run the setup. The GUI requires version 4.0; however, multiple versions such as 2.0, 3.0, and 5.0 can be installed simultaneously.

After installation is finished, a Skyworks Audio GUI icon will appear on your desktop. Launch the software by clicking this icon on the desktop as shown in Figure 24.



Figure 24. Launching the GUI

4.2. Board Initialization

After launching the GUI, you will be shown the initialization window as shown in Figure 25.

Note: This window can be accessed at any time by choosing Initialize from the File menu from the main GUI screen.

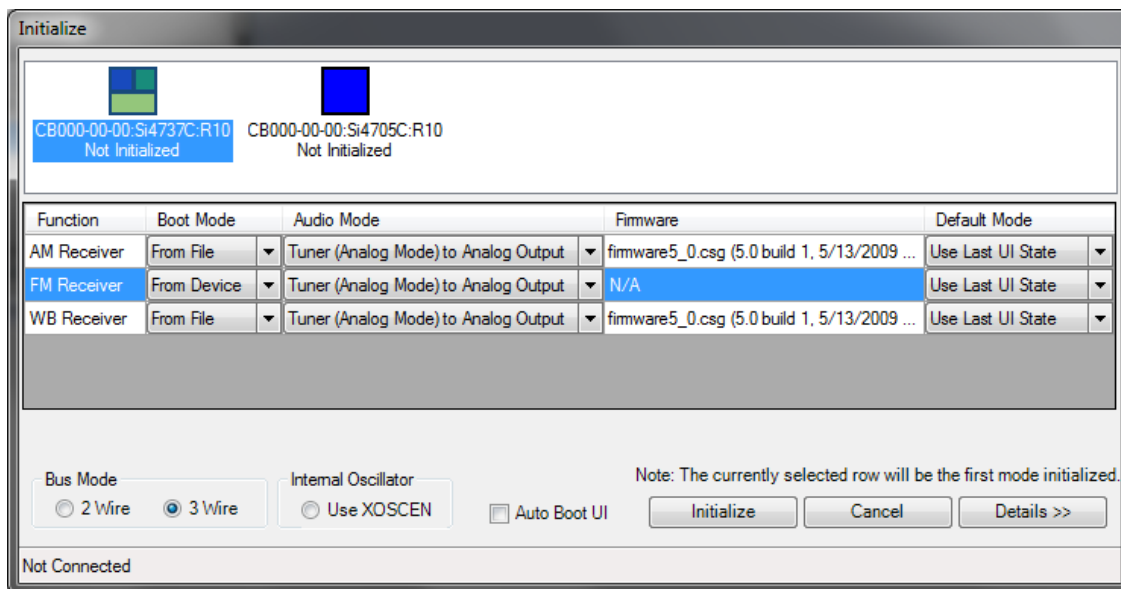

Figure 25. GUI Initialization Screen

4.2.1. Board Selection

At the top of the initialization window there is a board selection box, as displayed in Figure 26, that allows the selection of the board that will be controlled by the GUI. This box is populated automatically and will update real time as boards are connected/removed from the PC. If no EVBs are listed in the board selection box, verify that an EVB is connected to the USB port of the PC running the GUI application.

After selecting the desired board the GUI will populate the rest of the dialog with options appropriate to the board selected. You will only see modes/options for the type of board that is currently selected.

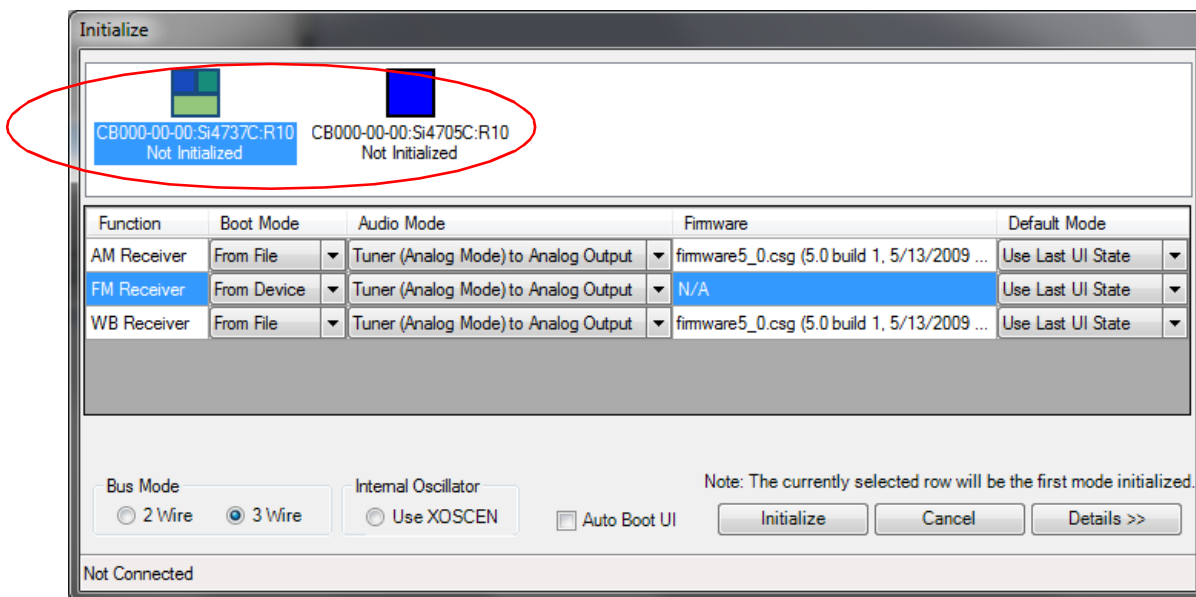

Figure 26. Board Selection Box

Si47xx-EVB

4.2.2. Board Discovery Bus Mode

The initialize process can be configured to use either 2-wire or 3-wire bus mode. This can be configured by selecting File → Board Discovery Bus Mode.

This feature is useful when using the Skyworks EVB and GUI to control a prototype that is designed to use one bus mode only.

4.2.3. Function Configuration

For each mode available on the selected EVB, multiple configuration items (Figure 27) will be present to allow for configuration of the GUI software. It is possible to change these settings to meet testing requirements. The default configuration of the board when you connect it to the computer is acceptable for most users. After initialization, the GUI will save and restore these settings whenever the same type of board is connected.

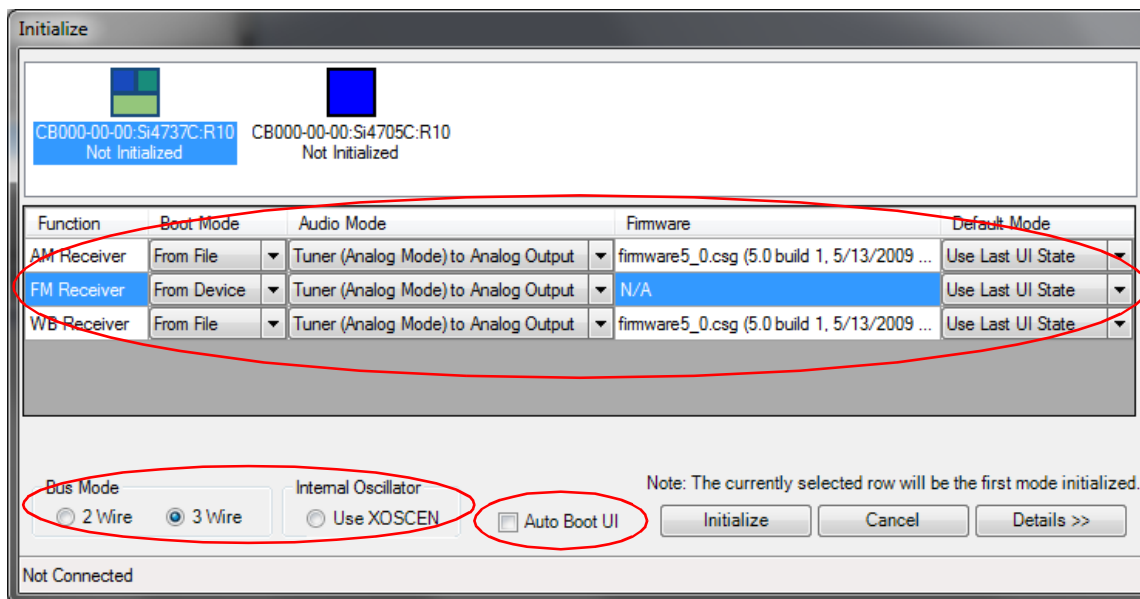

Figure 27. Mode Configuration Items

4.2.3.1. Functions

Currently the UI supports four possible functions. These functions are AM Receiver, FM Receiver, WB Receiver, and FM Transmitter.

Each function is configured independently from other functions. It is important to configure all functions as desired as it is possible to have FM Receive boot in digital mode while AM Receive boots in analog mode.

The currently highlighted function row will be the function that is initialized when the Initialize button is selected. Settings for other functions that are not selected will be saved and used to initialize that function when choosing another function from the UI main window.

4.2.3.2. Boot Mode

There are two boot modes possible for each function. It is possible for some boot modes to not be available on some boards.

- From Device—This option will use the firmware embedded on the device selected. This is the faster of the two options.
- From File—This option will use the patch functionality of the device to send firmware from a file stored within the UI to the device. If using this option, choose the appropriate firmware in the Firmware column for the function you are configuring.

4.2.3.3. Default Mode

There are two or more default modes possible for each function.

- Use Last UI State: When selected, the GUI will restore all settings on the device to the previous settings configured in the GUI the last time it was closed.
- Use Chip Defaults: When selected, the GUI will use the settings that were default in the firmware on the device. Only properties related to the correct setting of RCLK (such as frequency and prescaling) and initial tuning (such as frequency) will be changed. If an error occurs during initialization of a function, choose this setting to default the GUI settings back to the chip defaults.
- Saved Configuration States: If you have previously saved or imported any configuration states, they will be listed by name. When one of these is selected, the GUI will restore all settings on the device to the previously saved settings.

4.2.3.4. Audio Mode

This option allows the user to change between Analog or Digital modes if the board connected supports digital. Sections 2.1.4, 5, 6, and 7 each document the possible settings in more detail depending on what function is being configured.

Figure 28 displays the window after the Details button has been pressed which helps with selection of the Audio Mode by displaying a bitmap of the current audio setting in the dialog.

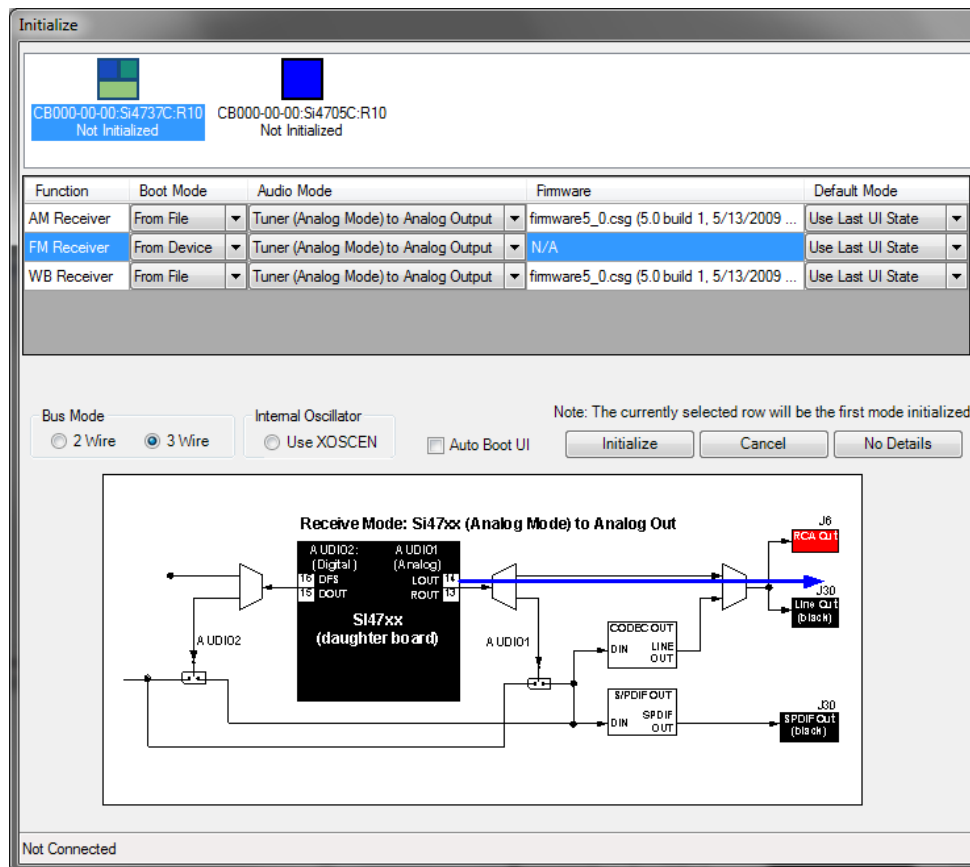

Figure 28. Expanded Details Dialog

4.2.3.5. Firmware

This selection is only required if "From File" was chosen for the Boot Mode. Use this setting to choose which firmware will be downloaded to the device. If this item turns red then there is no firmware available for the function so "From Device" must be chosen as the Boot Mode.

Si47xx-EVB

4.2.3.6. Bus Mode

This setting affects all functions that are configured. It allows the device to be booted either in 2-wire or 3-wire mode.

4.2.3.7. Internal Oscillator

When the "Use XOSCEN" is enabled and the board is configured to use the crystal oscillator, the GUI will boot the device using the crystal oscillator. This option is only available on devices that support the crystal oscillator option.

4.2.3.8. Auto Boot when UI Opened and only One Board is Connected

When this item is selected, the GUI, when launched, will automatically boot the board if the same board is connected. If more than one board is connected, the GUI will display the initialization dialog to allow selection of the board to initialize.

4.3. Switching Functions

After the board has been properly configured for all functions it is possible to switch between functions from the main UI window using the function buttons provided. Only function buttons will appear for the functions supported by the device currently running. Figure 29 highlights the buttons used to switch functions from the main screen.

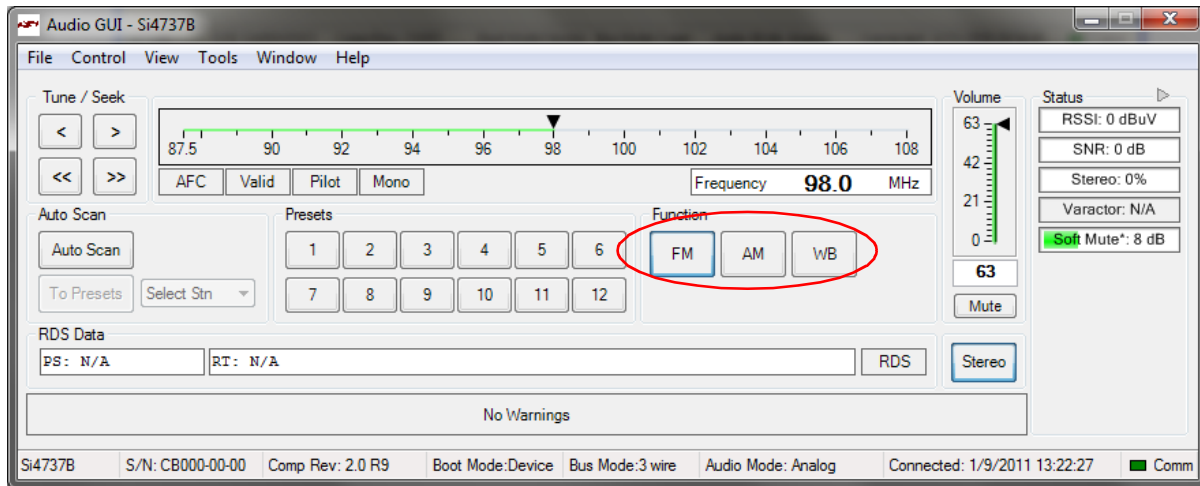

Figure 29. Function Switch Buttons

4.4. State Management

Once the part has been initialized, a State Management option becomes available in the File Menu. This GUI feature allows the user to save, retrieve, load, and delete the configuration state which contains the property values.

4.4.1. Save Configuration State

To save the current configuration state, select File→State Management→Save Current State. The Select Configuration window shown in Figure 30 will pop up. Enter a name for the configuration state and click OK. The current state that contains the property values is now saved under the given name. If a state already exists with the chosen name, the GUI will give you the option of replacing the original state, entering a different name, or canceling the save.

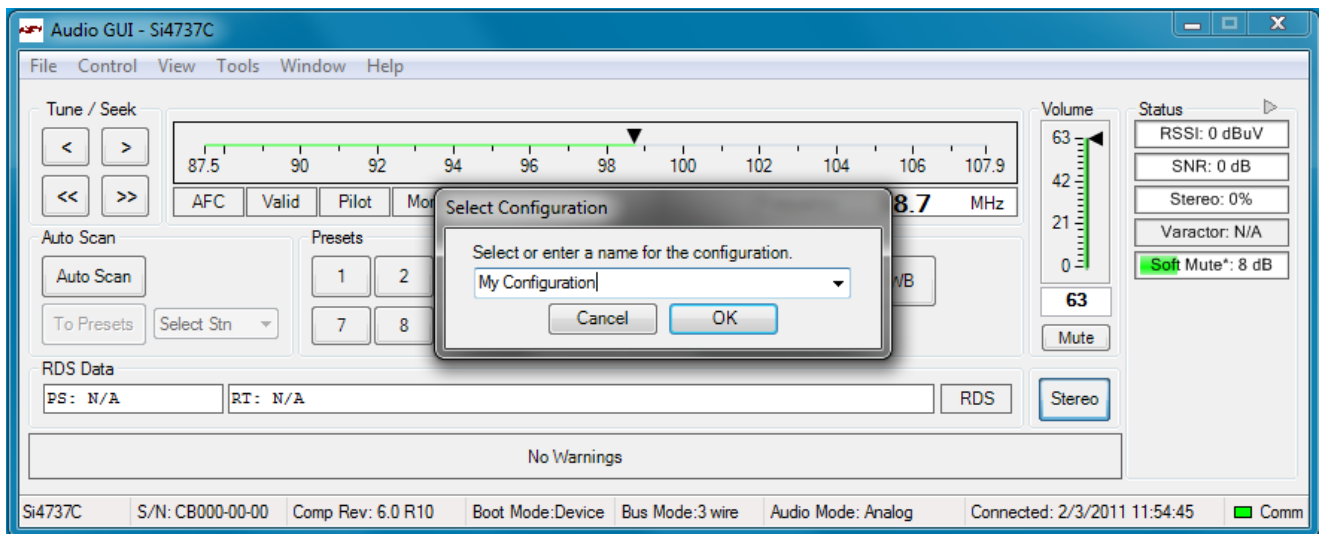

Figure 30. Naming a Configuration State during Save

4.4.2. Retrieve Configuration State

Once a configuration state for a part has been saved, it will appear in the Default Mode list in the Initialization window as shown in Figure 31. Select the state you wish to retrieve when initializing the part, and all properties and the tuning frequency of the saved configuration will be restored.

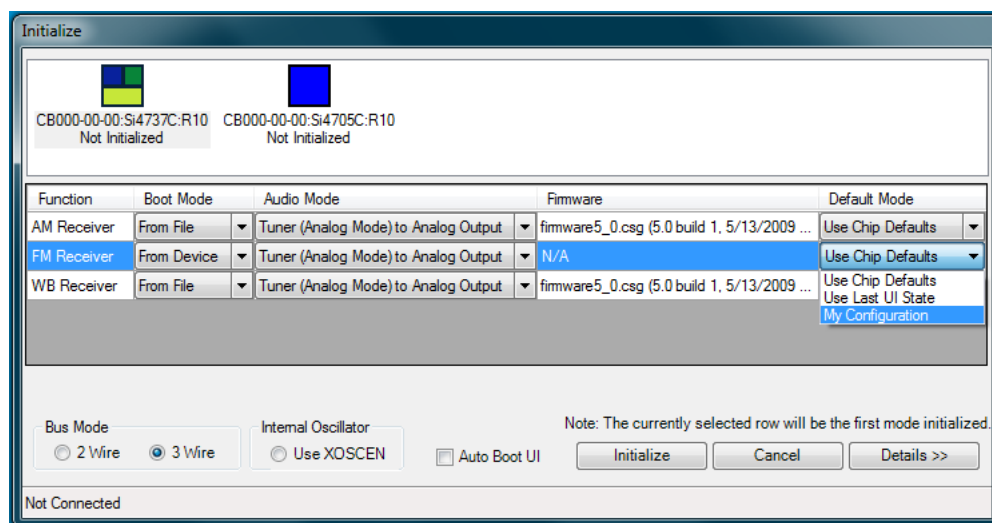

Figure 31. Saved Configuration State

Si47xx-EVB

4.4.3. Load Configuration State

When a configuration state for a part has been saved, it will also appear in the Load State list as shown in Figure 32. Select the state you wish to load, and all properties and the tuning frequency of the saved configuration will be restored without doing initialization to the chip.

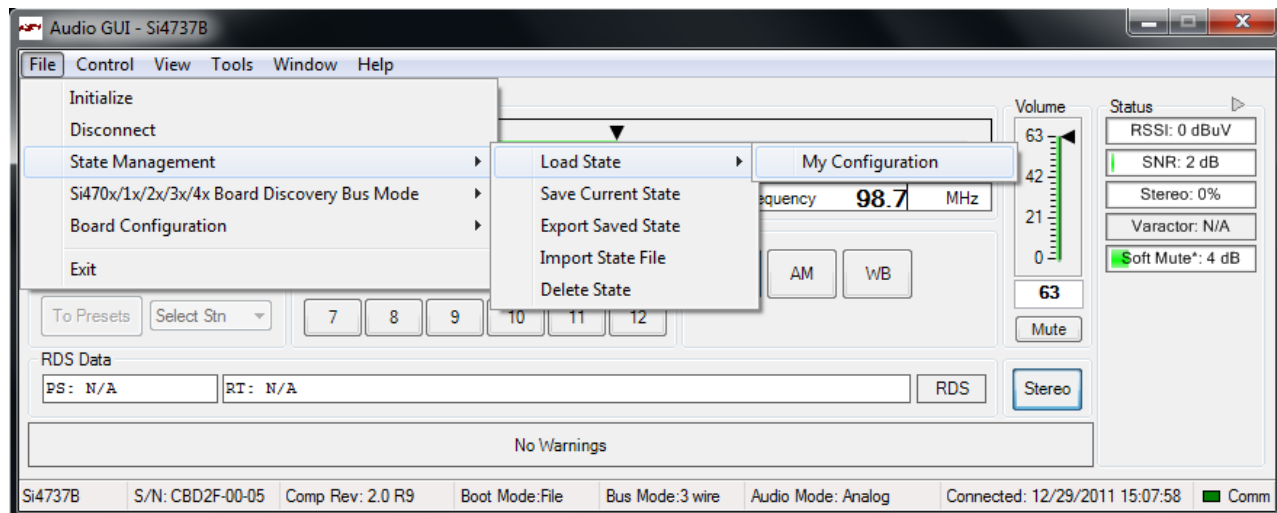

Figure 32. Loading Configuration State

4.4.4. Delete Configuration State

To discard a saved configuration state, select File→State Management→Delete State. The Delete Configuration window shown in Figure 33 will pop up. Select the configuration state you want to delete from the list and click OK. The deleted configuration state will no longer be available in the Default Mode list of the Initialization window or available for export.

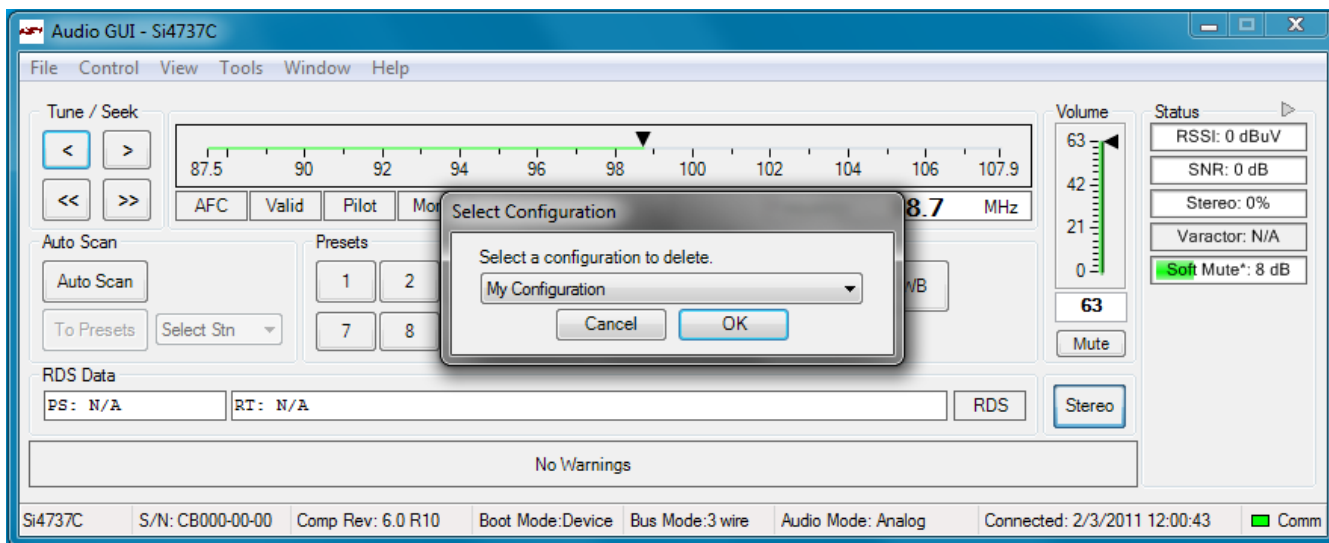

Figure 33. Selecting Configuration State to Delete

4.4.5. Export Saved State

In addition to saving, retrieving, and deleting the configuration state, the GUI also gives the end user the ability to export the configuration state to a file. The file can then be imported to installations of the GUI on different machines to allow multiple users to easily implement the same configuration state. To export a saved configuration state to a file, select File → State Management → Export Saved State and the Select Configuration window will pop up as shown in Figure 34. Select the configuration state to export and click OK to save the configuration file with a .ini extension. This configuration file can now be exported to different machines. The name of the saved state is retained in the file when exported.

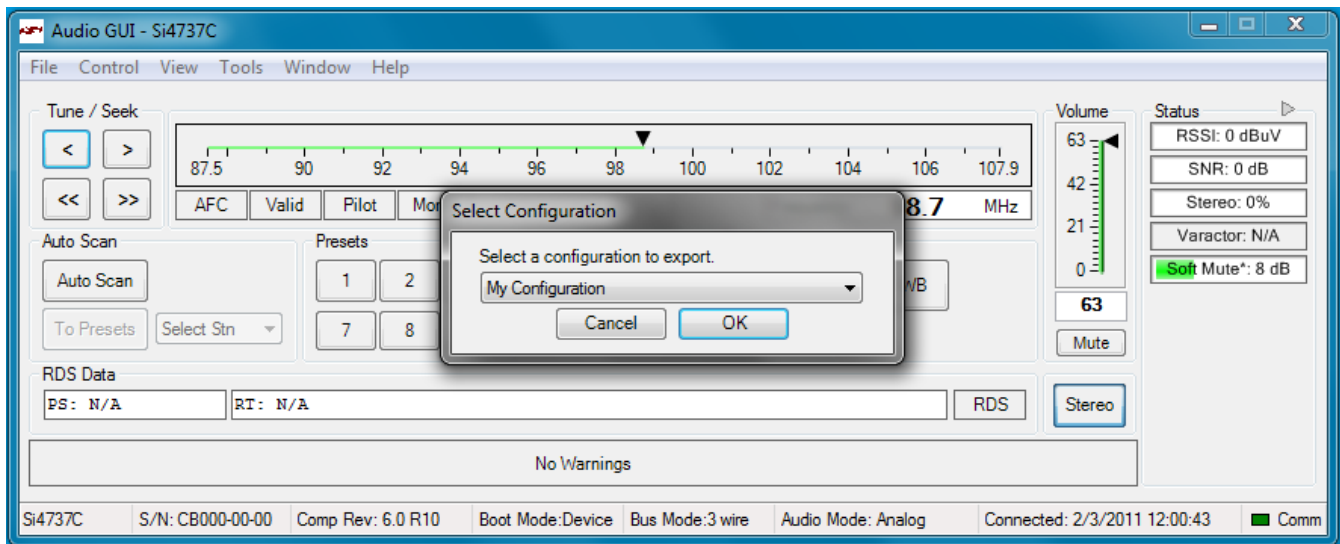

Figure 34. Selecting Configuration State to Export

4.4.6. Import Saved State

A saved configuration state can be imported from a .ini file exported by another instance of the GUI. To import a saved state, select File → State Management → Import State File, then browse for and select the desired file. Once the file has been imported, the saved state will appear in the Default Mode list in the Initialization window. If a state already exists with the same name as the state in the imported file, the GUI will give you the option of replacing the original state, choosing a new name for the imported state, or canceling the import from file. The name appearing in the initialization window will not necessarily be the same as the *.ini file name exported. It will reflect the name of the original state that was exported.

4.5. Disconnecting the EVB

The GUI provides three methods for disconnecting the device: Closing the GUI, choosing disconnect from the file menu, or physically disconnecting the device from the PC.

When closing the UI or selecting disconnect from the file menu, the GUI will prompt if the device should be powered down or not. This prompt allows for further investigation of the device after the GUI has been disconnected from the EVB. After the board has been disconnected through the File menu, the GUI will save the current state of the device to disk. This state will be used to power up the device in the same state next time the board is connected. The GUI will only save the current state if the board is disconnected through the File menu or the GUI application is closed. If the board is removed from the PC without being disconnected through the File menu and before the GUI is closed, then all state data will be lost.

Si47xx-EVB

5. FM Transmitter GUI

The first Si47xx window is the Initialization window as shown in Figure 35.

Select the FM transmitter function.

As an FM transmitter, there are three audio input settings available:

- Analog Input
- Analog to Digital Input
- Digital Input

5.1. Configuring the Si47xx as an FM Transmitter Using Analog Audio Input

This mode configures the Si47xx to receive analog audio input at pins 15 and 16 (LIN and RIN). The user has the ability to provide analog audio from RCA In connector (J7) or Line In (J19). Set jumpers J5 and J13 accordingly.

Figure 35 shows the configuration setting for analog audio input. Configure the desired parameters in the initialization screen and then click Initialize. A new window displaying "Initializing FM Transmitter" will appear.

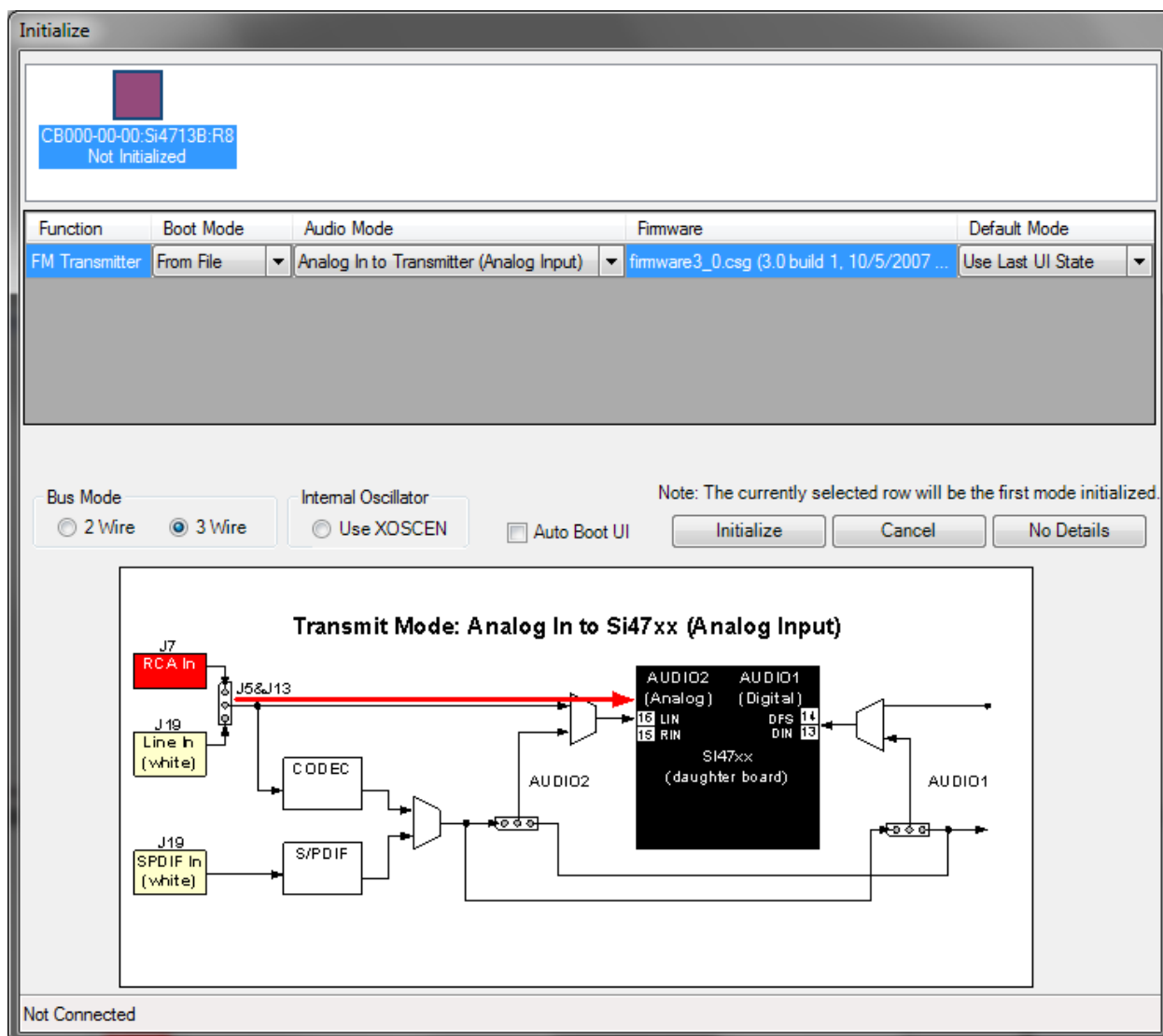

Figure 35. Configuring the Si47xx to Transmit Analog Input

5.2. Configuring the Si47xx as an FM Transmitter Using Digital Audio with Analog Audio Source

This mode configures the Si47xx to receive digital audio input at pins 13 and 14 (DIN and DFS), but the user still provides an analog audio source to the EVB. It is useful for a user who wants to test digital input on the Si47xx but does not have a digital audio source. The analog audio source is converted to digital audio through the CODEC, which can be configured to output various digital audio formats. Refer to Figure 41, “CODEC Settings Property Window,” on page 49 to control the CODEC. Configure the desired parameters in the initialization screen and then click Initialize. A new window displaying “Initializing FM Transmitter” will appear.

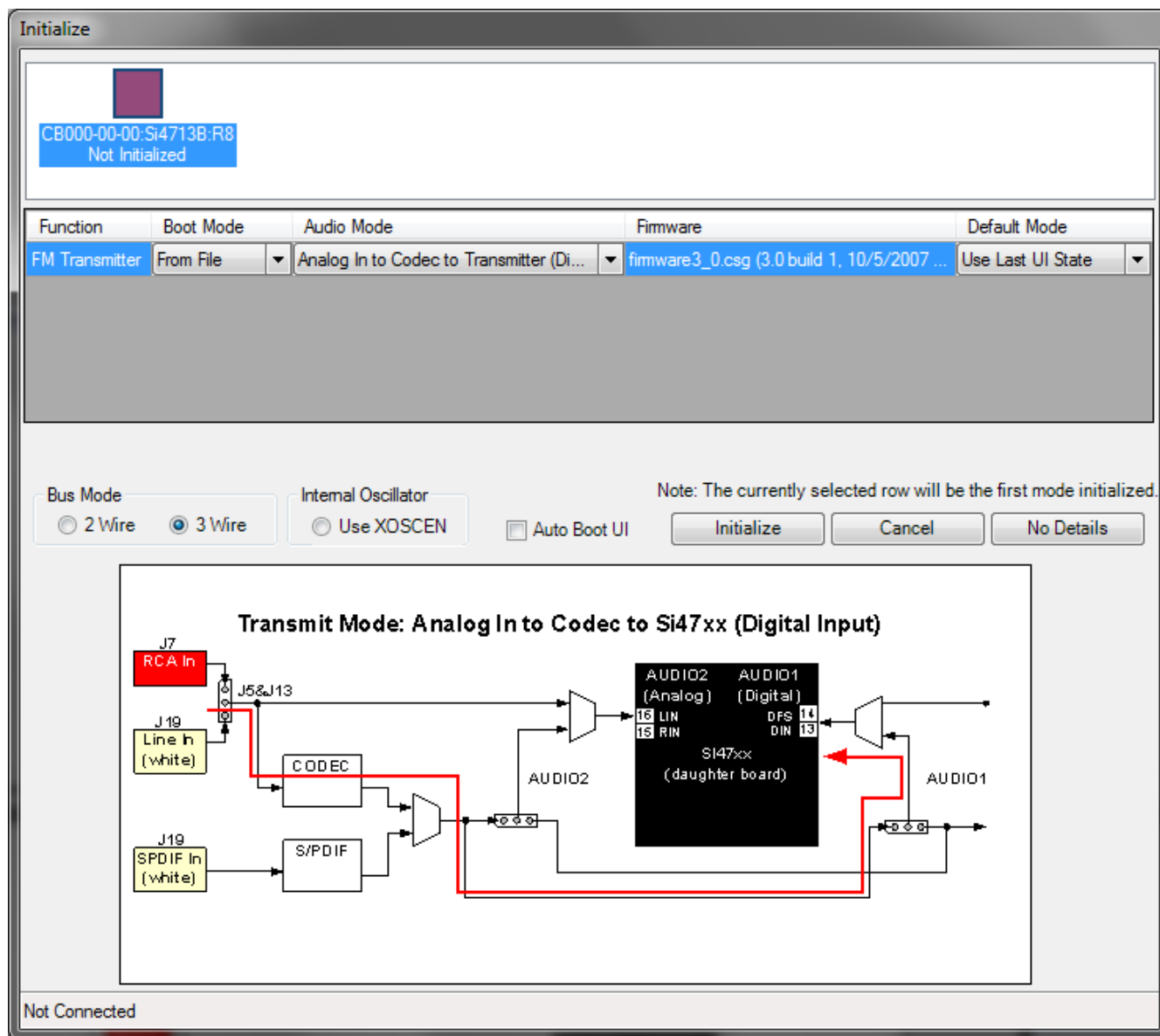

Figure 36. Configuring the Si47xx to Transmit Digital Input by Using Analog Source (CODEC)

Si47xx-EVB

5.3. Configuring the Si47xx as an FM Transmitter Using Digital Audio with SPDIF Digital Source

This mode configures the Si47xx to receive digital audio input at pin 13 and 14 (DIN and DFS) when the user has an SPDIF digital audio source. The SPDIF source is converted to PCM digital audio by the SPDIF translator. Refer to Figure 42, “SPDIF Settings Property Window,” on page 50 to control the SPDIF translator.

Note: The Si47xx requires the digital audio signal to be present when initializing the part. Therefore, connect the SPDIF IN signal prior to initializing the part. SPDIF will not be supported on new EVBs as of February 14, 2011. This mode of operation will not be available in the initialization window for those boards.

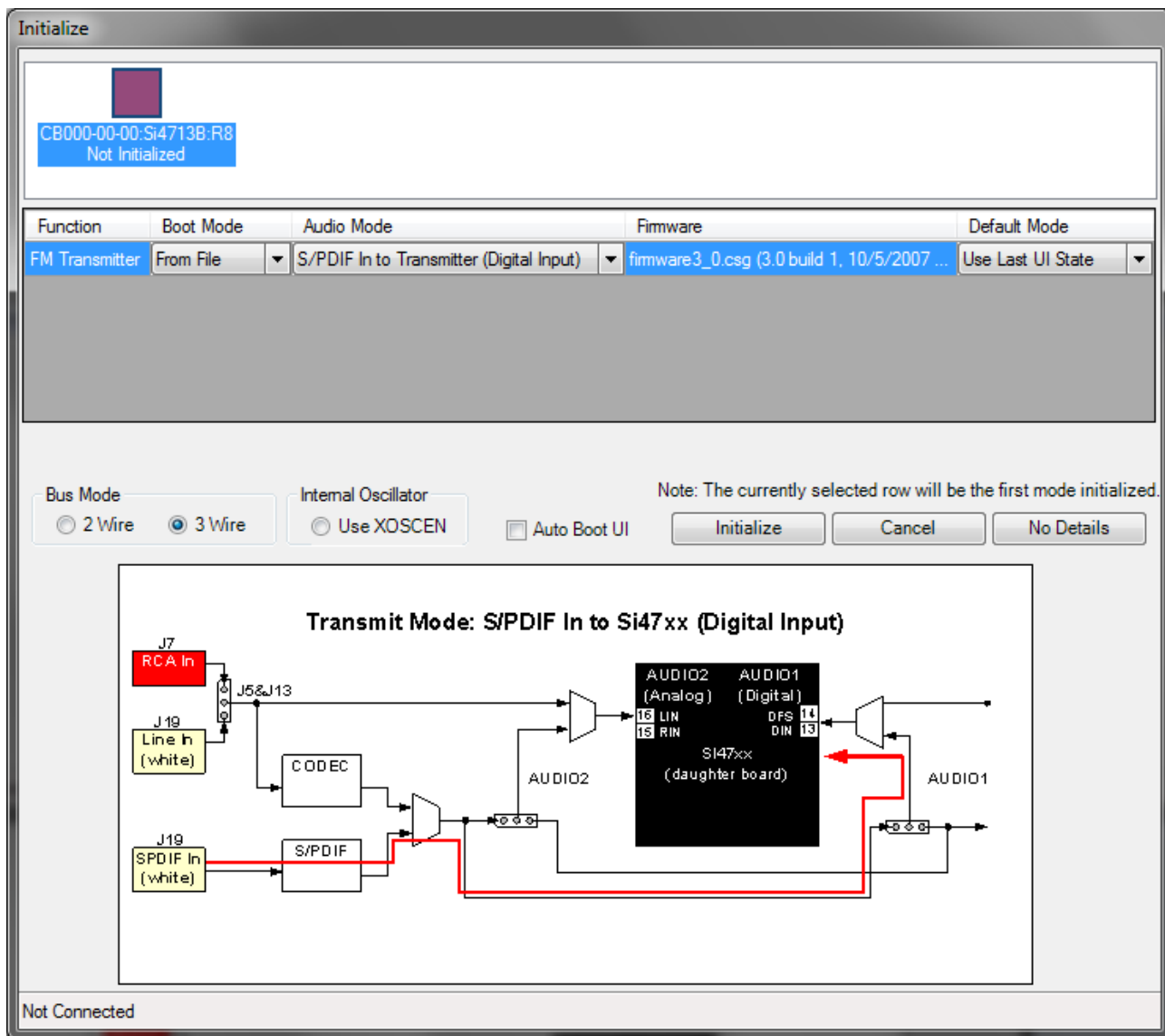

Figure 37. Configuring the Si47xx to Transmit Digital Input by Using Digital Source (SPDIF)

5.4. FM Transmitter Main Window

The FM transmitter main window will appear after initialization.

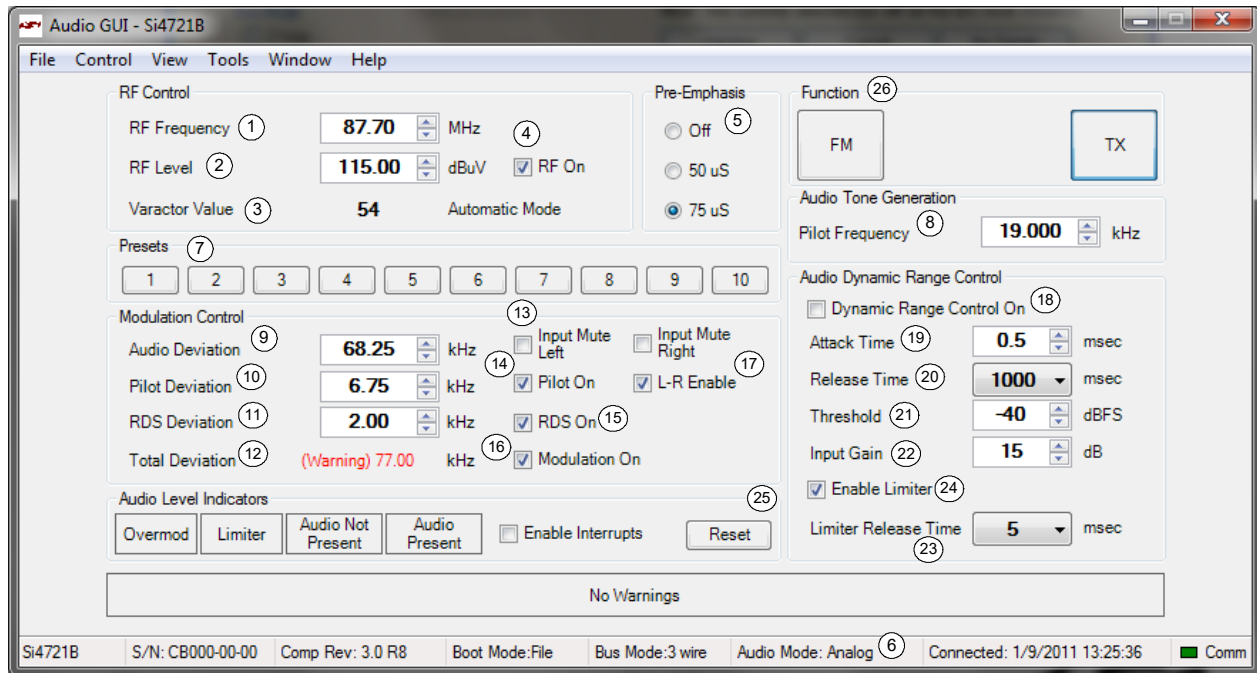

Figure 38. FM Transmitter Main Window

Table 8. FM Transmitter Main Window Descriptions

#	Description	Range
1	Transmit frequency display. Enter the desired FM transmit frequency in this window.	76–108 MHz
2	Transmit voltage display. Enter the desired FM transmit voltage in this window.	88–120 dBuV
3	Varactor Value. This is an indicator showing the tuning cap value of the Si472x device. Each number represents 0.25 pF. If the varactor value is manually overwritten in the property window, the indicator will change from automatic mode to manual mode.	1–191
4	RF on or off. Selecting this checkbox will enable the FM transmit, while turning this button off will disable the FM transmit.	On/Off
5	Pre-Emphasis. Click one of the three buttons to set the pre-emphasis either to Off, 50 μ s or 75 μ s.	Off, 50 μ s, 75 μ s
6	Si472x EVB audio input setting indicator: Analog In/Digital (Analog In to CODEC)/Digital (SPDIF).	Analog, Digital CODEC, Digital SPDIF
7	Presets. Press and hold the desired preset button for 1.5 seconds to program. The current frequency will replace the preset number. Press for less than 1.5 seconds to tune to the displayed frequency. Presets can also be programmed automatically from the Receive Power Scan window.	76–108 MHz
8	Pilot Tone Generation. Set to 19 kHz and select "Pilot On" when in stereo mode. Set to 0–19 kHz for and select "Pilot On" for test tone generation.	0–19 kHz
9	Audio Deviation. Enter the desired audio deviation in this window.	0–90 kHz
10	Pilot Deviation. Enter the desired pilot deviation in this window.	0–90 kHz

Si47xx-EVB

Table 8. FM Transmitter Main Window Descriptions (Continued)

#	Description	Range
11	RDS Deviation. Enter the desired RDS deviation in this window (Si4711/13/21 only).	0–7.5 kHz
12	Total Deviation. This is an indicator only displaying the sum of the audio, pilot and RDS deviation. If the total deviation exceeds 75 kHz, the indicator will turn red and a warning sign is displayed.	0–187.5 kHz
13	Input Mute Left/Right. Selecting this checkbox will mute the Left or Right audio channel.	On/Off
14	Turn on or off the pilot tone for stereo or mono FM transmit mode.	On/Off
15	Turn on or off the RDS transmission (Si4711/13/21 only).	On/Off
16	Modulation On. Selecting this checkbox will modulate the audio, pilot, and RDS signal according to the audio, pilot, and RDS deviation. De-selecting this checkbox will turn off modulation for all audio, pilot, and RDS signal and only the carrier will be transmitted.	On/Off
17	Turn on or off the L-R channel for stereo or mono FM transmit mode.	On/Off
18	Turn on or off the compressor for the audio signal.	On/Off
19	Attack time. Set the attack time for the compressor in milliseconds.	0.5–5 ms
20	Release time. Set the release time for the compressor in milliseconds.	100–1000 ms
21	Threshold. Set the threshold for the compressor.	–40 to 0 dBFS
22	Input Gain. Set the compressor gain.	0 to 20 dB
23	Limiter Release Time. Set the limiter release time constant. (Not available in Si4710-A10).	0.5, 1, 2, 3, 4, 5, 6, 7, 8, 9, 10, 20, 30, 40, 50, 75, 100 ms
24	Turn on or off the limiter feature.	On/Off
25	Audio Level Indicators. Overmodulation, Limiter, Audio input level below low-level threshold (silence detection), and Audio input level below high-level threshold (loud detection). To enable these four indicators, check the Enable Interrupts box. These indicators are sticky; to clear them, click the Reset button.	
26	Mode switch buttons to switch between different modes on the device. See section 4 for more information.	

5.5. FM Transmitter Settings (Analog Mode) Property Window

FM transmitter settings can be configured through the properties window by selecting Window→Properties. Properties are grouped into categories which can be selected from the drop-down box in the upper right of the window. For convenience, all FM transmitter properties are also located in Window→Properties→TX: All. Analog mode properties will be available if Analog Mode was selected in the initialization window.

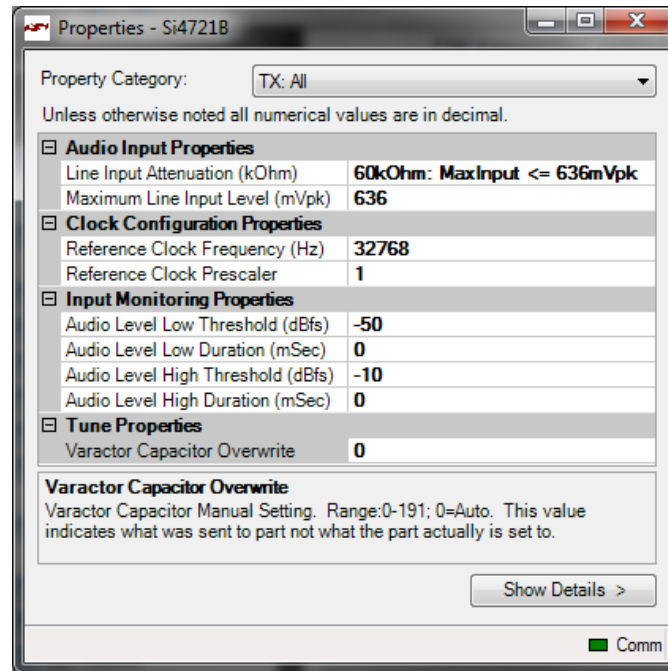

Figure 39. FM Transmitter Settings in Analog Mode Property Window

Table 9. FM Transmitter Settings in Analog Mode Property Window Descriptions

Item	Description	Range	Devices
Line Input Attenuation (k Ω)	The Si47xx has four attenuator settings (636, 416, 301, and 190 mVp). It will tell the maximum audio input signal that the user can give to the LIN and RIN input. The attenuator setting will determine the audio input impedance (LIN and RIN) of the device.	190 mVp, 301 mVpk, 416 mVp, 636 mVpk	All
Maximum Line Input Level (mVpk)	The maximum line input level of the max audio input signal that the user supplies to the device. This number has to be less than or equal to the attenuation setting. The max line input level will correspond to the max audio deviation set in the audio deviation window on the main GUI. Make sure that the actual audio input signal does not exceed this limit, otherwise the audio signal will become distorted.	0–Line Input Attenuation	All
Reference Clock Frequency (Hz)	This field is used to specify the frequency of the reference clock. The input to the RCLK pin divided by the prescaler is the reference clock. The reference clock must be in the range of 31130 to 34406 Hz.	31130–34406 Hz	All

Si47xx-EVB

Table 9. FM Transmitter Settings in Analog Mode Property Window Descriptions (Continued)

Item	Description	Range	Devices
Reference Clock Prescaler	This field is used to specify the prescaler value. The input to the RCLK pin divided by the prescaler is the reference clock. The reference clock must be in the range of 31130 to 34406 Hz.	1–4095	All
Audio Level High Duration (mSec)	Set the duration for the audio level high before an interrupt is generated.	0–65535	All
Audio Level High Threshold (dBFS)	An interrupt will be generated when the audio input level rises above this threshold for the duration greater than the Audio Level High Duration setting. This may also be called loud detection indicator.	–70 to 0	All
Audio Level Low Duration (mSec)	Set the duration for the audio level low before an interrupt is generated.	0–65535	All
Audio Level Low Threshold (dBFS)	An interrupt will be generated when the audio input level falls below this threshold for the duration greater than the Audio Level Low Distortion setting. This may be called silence detection indicator.	–70 to 0	All
Varactor Capacitor Overwrite	This field allows the user to manually overwrite the tuning capacitance. A number 0 indicates that the tuning cap is automatically adjusted. Any number other than 0 (1 to 191) will indicate that the tuning cap is manually adjusted.	Automatic: 0, Manual: 1–191	All

5.6. FM Transmitter Settings (Digital Mode) Property Window

FM transmitter settings can be configured through the properties window by selecting Window→Properties. Properties are grouped into categories which can be selected from the drop-down box in the upper right of the window. For convenience, all FM transmitter properties are also located in Window→Properties →TX: All. Digital mode properties will be available if CODED or SPDIF modes was selected in the initialization window.

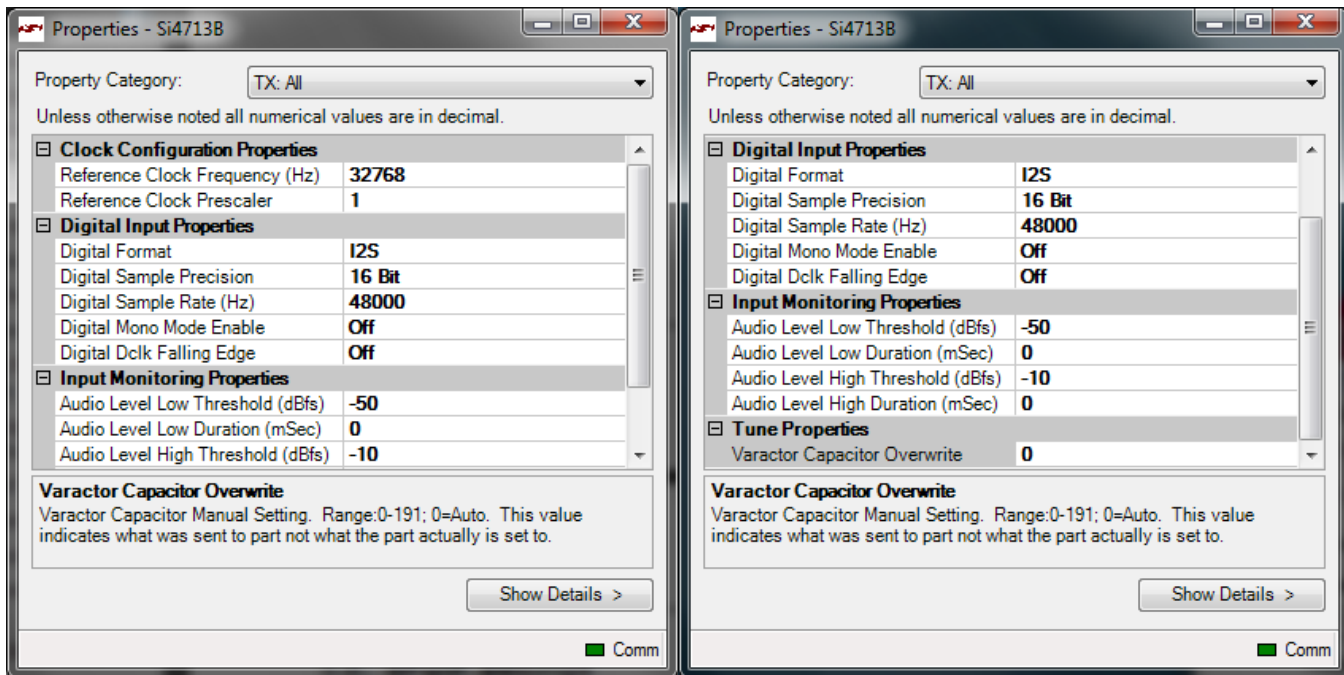

Figure 40. FM Transmitter Settings in Digital Mode Property Window

Table 10. FM Transmitter Settings in Digital Mode Property Window Descriptions

Item	Description	Range	Applicable Devices
Reference Clock Frequency (Hz)	This field is used to specify the frequency of the reference clock. The input to the RCLK pin divided by the prescaler is the reference clock. The reference clock must be in the range of 31130 to 34406 Hz.	31130–34406 Hz	All
Reference Clock Prescaler	This field is used to specify the prescaler value. The input to the RCLK pin divided by the prescaler is the reference clock. The reference clock must be in the range of 31130 to 34406 Hz.	1–4095	All
Digital Format	Sets I ² S of left justified digital format.	Left-Justified, I ² S, DSP (MSB on first DCLK), or DSP (MSB on second DCLK)	All except Si4710-A10
Digital Sample Precision	Select the precision of the digital audio input.	8, 16, 20, 24 bits	All
Digital Sample Rate (Hz)	Sets the DFS digital sample rate. Must be set to 0 Hz before DCLK/DFS is removed.	0, 32000–48000 Hz	All except Si4710-A10

Si47xx-EVB

Table 10. FM Transmitter Settings in Digital Mode Property Window Descriptions (Continued)

Item	Description	Range	Applicable Devices
Digital Mono Mode Enable	Select between Digital Stereo or Mono.	On/Off	All
Digital DCLK Falling Edge	Select between using rising edge or falling edge of DCLK when sampling Digital Input (DIN) data.	On/Off	All
Audio Level Low Threshold (dBFS)	An interrupt will be generated when the audio input level falls below this threshold for the duration greater than the Audio Level Low Distortion setting. This may be called silence detection indicator.	-70 to 0	All
Audio Level Low Duration (mSec)	Set the duration for the audio level low before an interrupt is generated.	0-65535	All
Audio Level High Threshold (dBFS)	An interrupt will be generated when the audio input level rises above this threshold for the duration greater than the Audio Level High Duration setting. This may also be called loud detection indicator.	-70 to 0	All
Audio Level High Duration (mSec)	Set the duration for the audio level high before an interrupt is generated.	0-65535	All
Varactor Capacitor Overwrite	This field allows the user to manually overwrite the tuning capacitance. 0 indicates that the tuning cap is automatically adjusted. Any number other than 0 (1 to 191) will indicate that the tuning cap is manually adjusted.	Automatic: 0 Manual: 1-191	All

5.7. CODEC Settings

In addition to other digital mode properties, a category of CODEC settings may be configured by selecting Window→Properties→CODEC Settings if CODEC mode was selected in the initialization window.

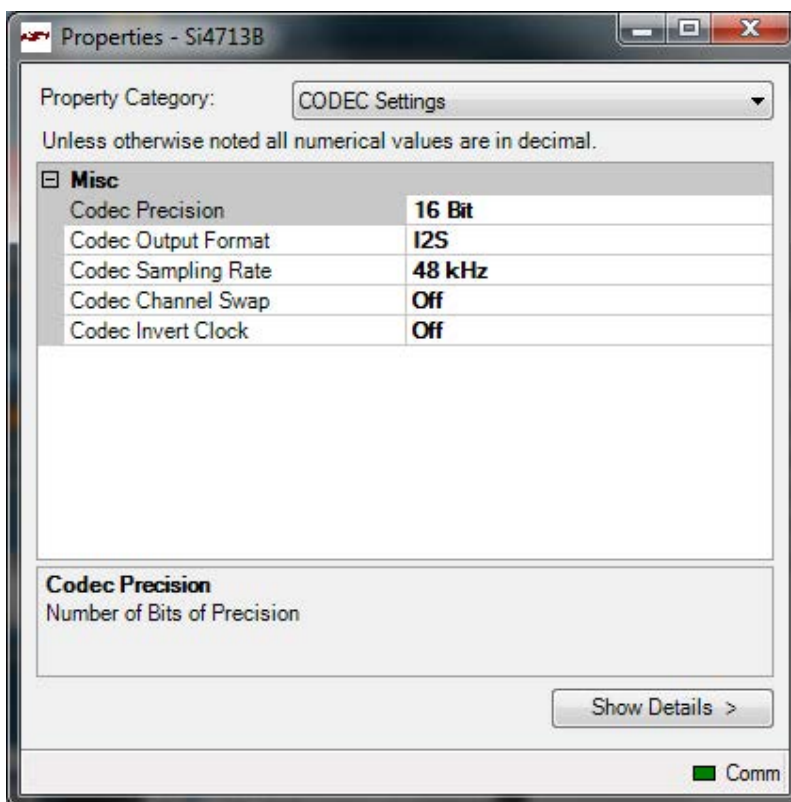

Figure 41. CODEC Settings Property Window

Table 11. CODEC Settings Property Window Descriptions

Item	Description	Range
Misc.		
CODEC Precision	Select the CODEC digital audio output precision.	16, 20, 24 bits
CODEC Output Format	Select the CODEC digital audio format between I ² S, Left Justified, DSP (MSB on first DCLK), or DSP (MSB on second DCLK).	Left-Justified, I ² S, DSP (MSB on first DCLK), or DSP (MSB on second DCLK)
CODEC Sampling Rate	Select the sample rate of the CODEC digital audio output.	32 or 48 kHz
CODEC Channel Swap	Select whether the CODEC digital output L-R data is normal or swapped.	On/Off
CODEC Invert Clock	Select between using rising edge or falling edge of DCLK when sampling Digital Input (DIN) data.	On/Off

Si47xx-EVB

5.8. SPDIF Settings

In addition to other digital mode properties, a category of SPDIF settings may be configured by selecting Window→Properties→SPDIF Settings if SPDIF mode was selected in the initialization window.

Note: SPDIF will not be supported on new EVBs as of February 14, 2011. These properties will not be available through the GUI in conjunction with those boards.

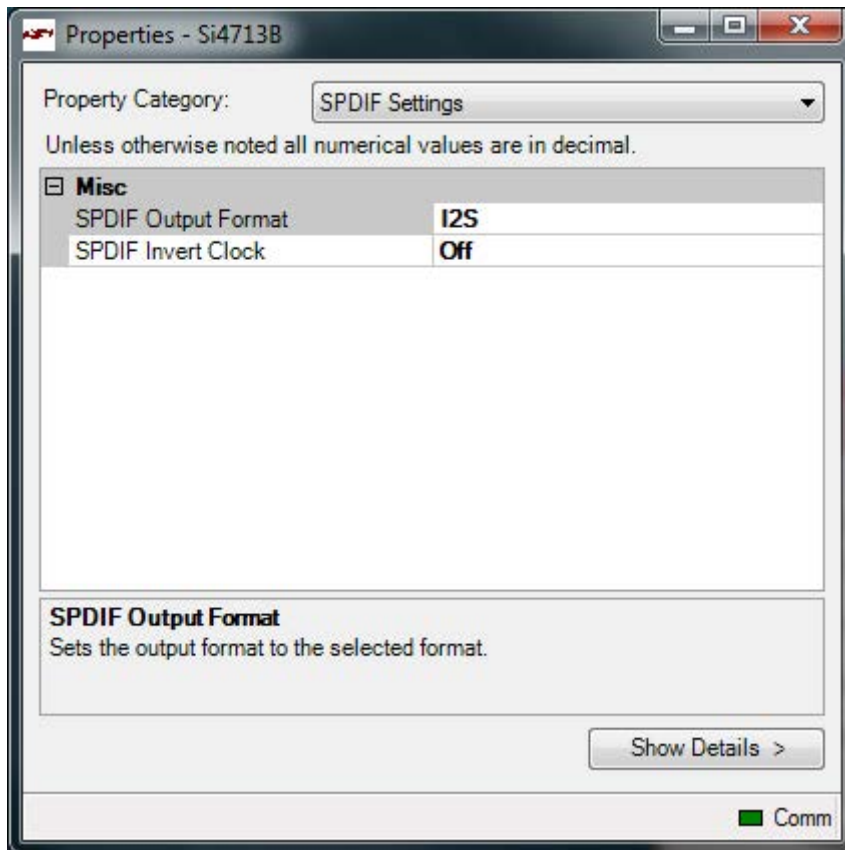

Figure 42. SPDIF Settings Property Window

Table 12. SPDIF Settings Property Window Descriptions

Item	Description	Range
Misc.		
SPDIF Invert Clock	Select between using rising edge or falling edge of DCLK when sampling Digital Input (DIN) data.	On/Off
SPDIF Output Format	Select the SPDIF digital audio format between I ² S or Left Justified.	Left-Justified or I ² S

5.9. FM Transmitter Receive Power Scan Window

The Receive Power Scan window enables the user to scan the entire FM band to find one or more candidate channels on which to transmit, where candidate channels are defined as those with the lowest received power. Selecting Window→Power Scan will launch the Receive Power Scan Window as shown in Figure 43. The band and channel spacing can be selected and the number of regions can be set to return one to ten candidate channels. The number of channels to average can be set to 1, 3, 5, or 7. Selecting “To Presets” will save the candidate channels to the GUI presets. Refer to "AN307: Si4712/13/20/21 Receive Power Scan" for additional information on the RPS feature and algorithm.

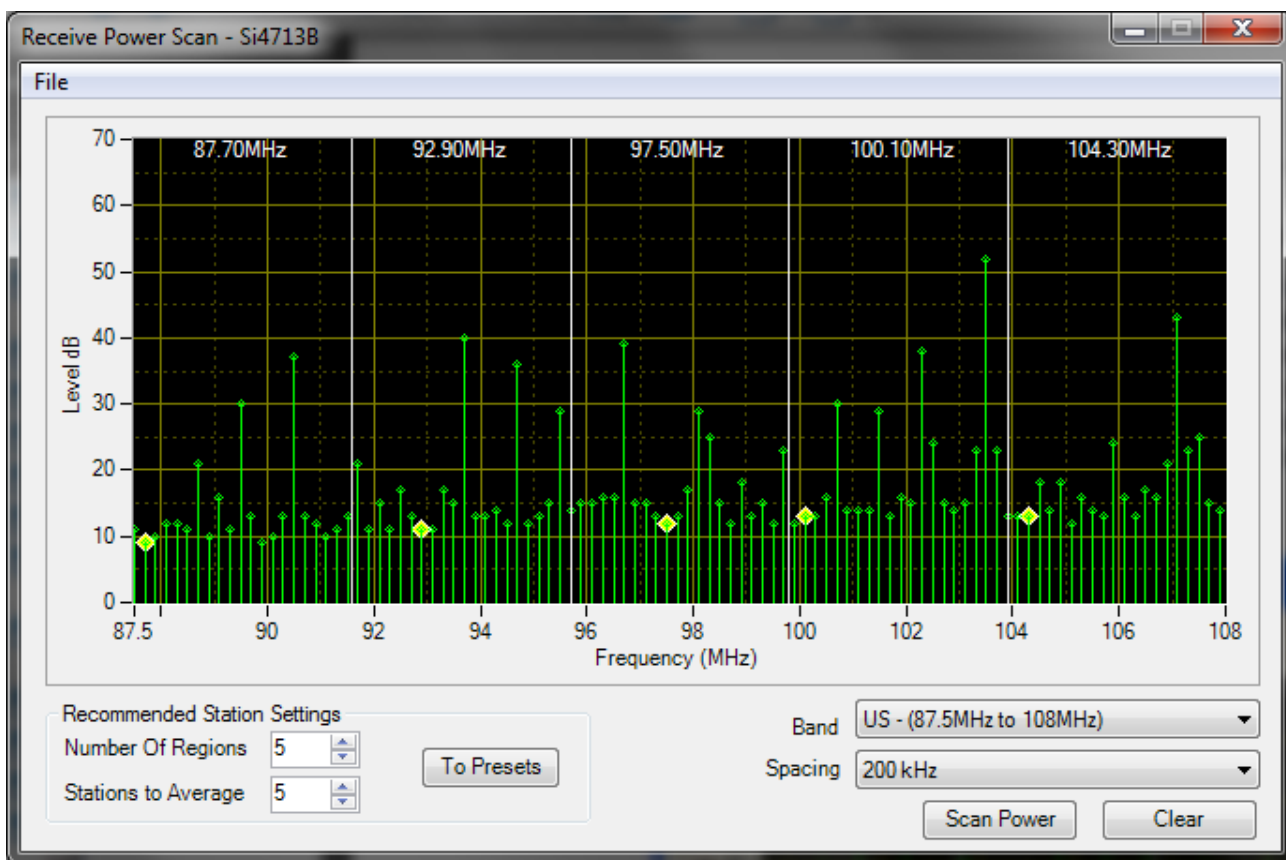

Figure 43. Receive Power Scan Window

Si47xx-EVB

5.10. FM Transmitter Radio Data Service (RDS)

The RDS/RBDS feature is available with the Si4711/13/21. This user guide assumes that the user is already familiar with the RDS/RBDS standard. If necessary, the user may refer to the following documents to become familiar with the RDS/RBDS standard.

- United States RBDS Standard by National Radio Systems Committee, April 9, 1998.
- RDS Universal Encoded Communication Protocol Version 5.1 by European Broadcasting Union, August 1997.
- Skyworks “AN243: Using RDS/RBDS with the Si4701/03.”

In order for the user to transmit RDS, check the RDS On box. Failure to turn on RDS means that the RDS data will not be transmitted. The following picture illustrates the RDS On box that should be turned on.

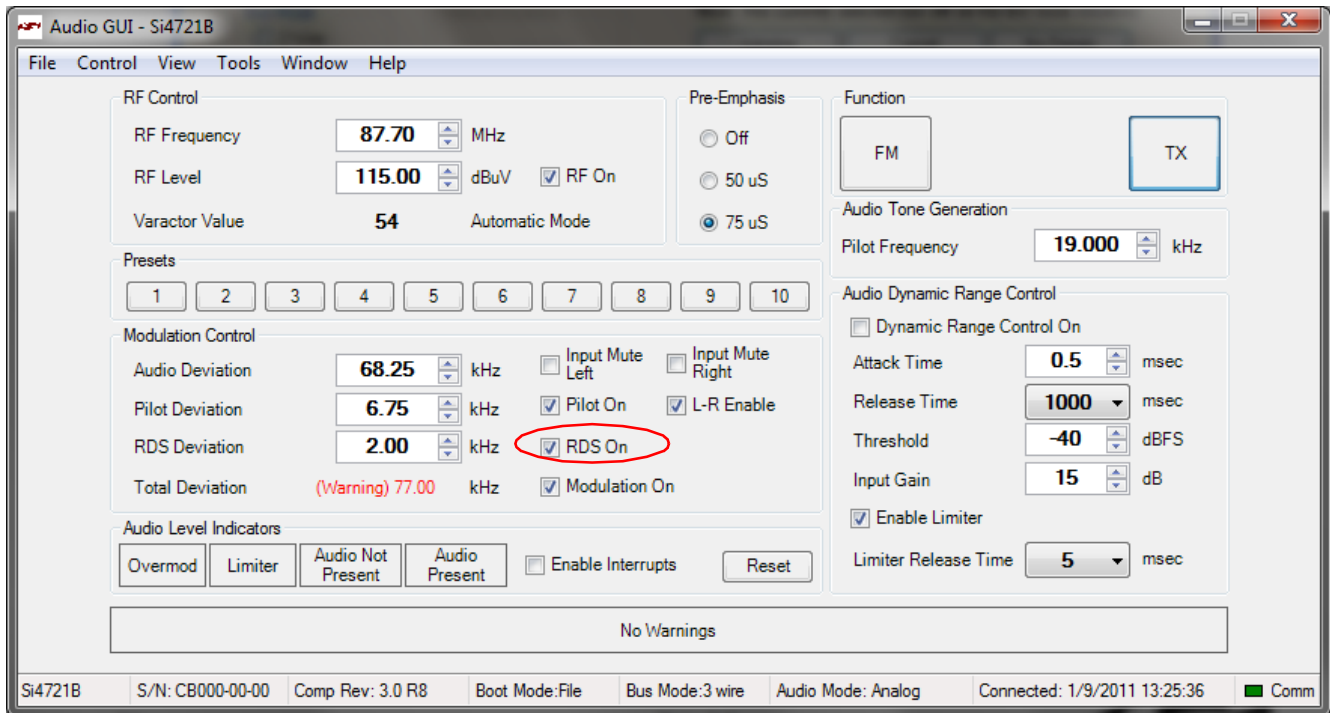

Figure 44. Turning RDS On in the FM Transmitter Main Window

After the RDS transmission is enabled, click on Window→RDS Transmit Data to go to the RDS Transmit Data screen. This window allows the user to configure RDS data to be transmitted and also allows the user to gain insight to the Si4711/13/21 RDS capability.

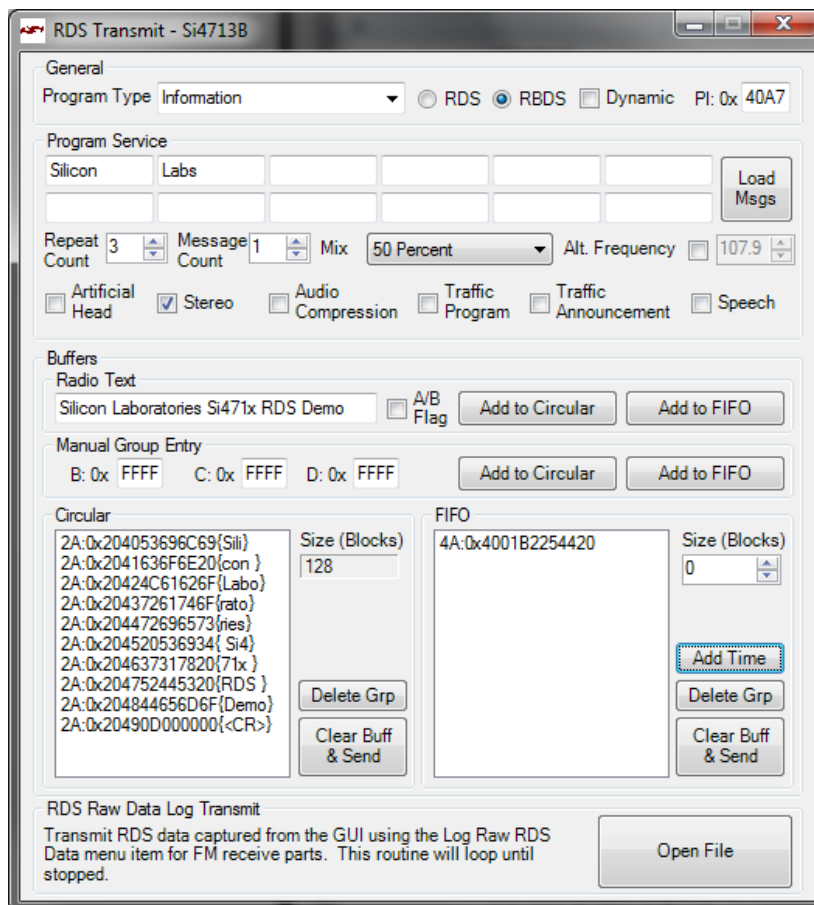

Figure 45. RDS Transmit Window

Table 13. RDS Transmit Window Descriptions

Item	Description
General	
RDS/RBDS Selection	Select either RDS format (Europe) or RBDS format (US).
Program Type (PTY)	Select the available Program Type (PTY) from the pulldown menu.
PTY Dynamic	Select whether the PTY will be dynamic or static.
PI	Enter Program Identification (PI) code here.
Program Service	
Program Service Messages	Enter up to 12 different Program Service (PS) Messages. Each PS consists of a maximum 8 characters. Messages are ordered left to right, top to bottom.
Load Msgs	Load the PS messages into the device.
Repeat Count	Enter how many time each PS will be repeated before sending the next PS.
Message Count	Enter how many messages of the loaded PS that will be transmitted.
Mix	Select the mix percentage between transmitting the Program Service or Buffers.
Alternate Frequency	Part of RDS Group Type 0 (PS): Enter Alternate Frequency if it is available.
Artificial Head	Part of RDS Group Type 0 (PS): Enter whether Artificial Head is On or Off.

Table 13. RDS Transmit Window Descriptions

Item	Description
Stereo	Part of RDS Group Type 0 (PS): Enter whether the transmitted audio is Stereo or Mono.
Audio Compression	Part of RDS Group Type 0 (PS): Enter whether the Audio Compression is On or Off.
Traffic Program	Part of RDS Group Type 0 (PS): Enter whether Traffic Program is available or not.
Traffic Announcement	Part of RDS Group Type 0 (PS): Enter whether Traffic Announcement is available or not.
Speech	Part of RDS Group Type 0 (PS): Enter between Speech or Music transmission.
Buffers	
Radio Text	Enter the RDS Group Type 2 Radio Text (RT) messages that will be loaded into either the circular or FIFO buffer.
Radio Text: A/B Flag	Part of RDS Group Type 2 (RT): Enter whether the A/B Flag is set or not in entering the RT. This A/B Flag will tell the receiver to clear the display when the flag toggles from one state to the other.
Radio Text: Add to Circular	Add the RT messages that are entered into the GUI circular buffer queue.
Radio Text: Add to FIFO	Add the RT messages that are entered into the GUI FIFO buffer queue.
Manual Group Entry: B	Enter manual RDS entry block B. With this window, you can transmit all RDS Group Types 0 through 15.
Manual Group Entry: C	Enter manual RDS entry block C. With this window, you can transmit all RDS Group Types 0 through 15.
Manual Group Entry: D	Enter manual RDS entry block D. With this window, you can transmit all RDS Group Types 0 through 15.
Manual Group Entry: Add to Circular	Add the RDS manual entry values into the GUI circular buffer queue.
Manual Group Entry: Add to FIFO	Add the RDS manual values into the GUI FIFO buffer queue.
Circular	Indicator showing the GUI circular buffer queue.
Circular: Size (Blocks)	Indicator showing the size (in blocks) of the circular buffer. The total size of the buffer is 128, which is shared between the circular and FIFO buffers. To adjust the size, change the size in the FIFO buffers.
Circular: Delete Group	Delete the currently selected group in the GUI circular buffer queue.
Circular: Clear Buffer & Send	Clear the circular buffer on the device and send the messages in the GUI circular buffer queue to the device.
FIFO	Indicator showing the GUI FIFO queue.
FIFO: Size (Blocks)	Indicator showing the size (in blocks) of the FIFO buffer. Adjusting the size of the FIFO will also adjust the size of the circular buffer. The total of those two buffers is 128 blocks.
FIFO: Add Time	This will get the current time and format it into RDS Group Type 4 Clock & Time (CT), and add it to the GUI FIFO buffer queue.
FIFO: Delete Group	Delete currently selected group in the GUI FIFO buffer queue.
FIFO: Clear Buffer & Send	Clear the FIFO buffer on the device and send the message in the GUI FIFO buffer queue to the device.

There are 16 different group types in the RDS/RBDS standard, and for every group the following information is always transmitted:

1. Program Identification (PI)
2. Program Type (PTY)

The GUI makes it easy to send data in three of the following group types:

1. Group Type 0: Program Service (PS)
2. Group Type 2: Radio Text (RT)
3. Group Type 4: Clock Time (CT)

It is possible to send data in the other group types, but the user has to manually enter the data in hexadecimal code.

Because of the complexity of the RDS/RBDS standard, the explanation of the RDS Transmit Data window is divided into three sections: Basic, Intermediate, and Advanced.

Si47xx-EVB

5.10.1. Basic

The RDS Transmit Window is divided into three categories:

1. General
2. Program Service
3. Buffers

In the basic section, we will cover two out of the three categories: the General and Program Service. In the General category, the user can set the PI and PTY data. In the Program Service, the user can set the PS data (Group Type 0). The following diagram shows a step-by-step explanation:

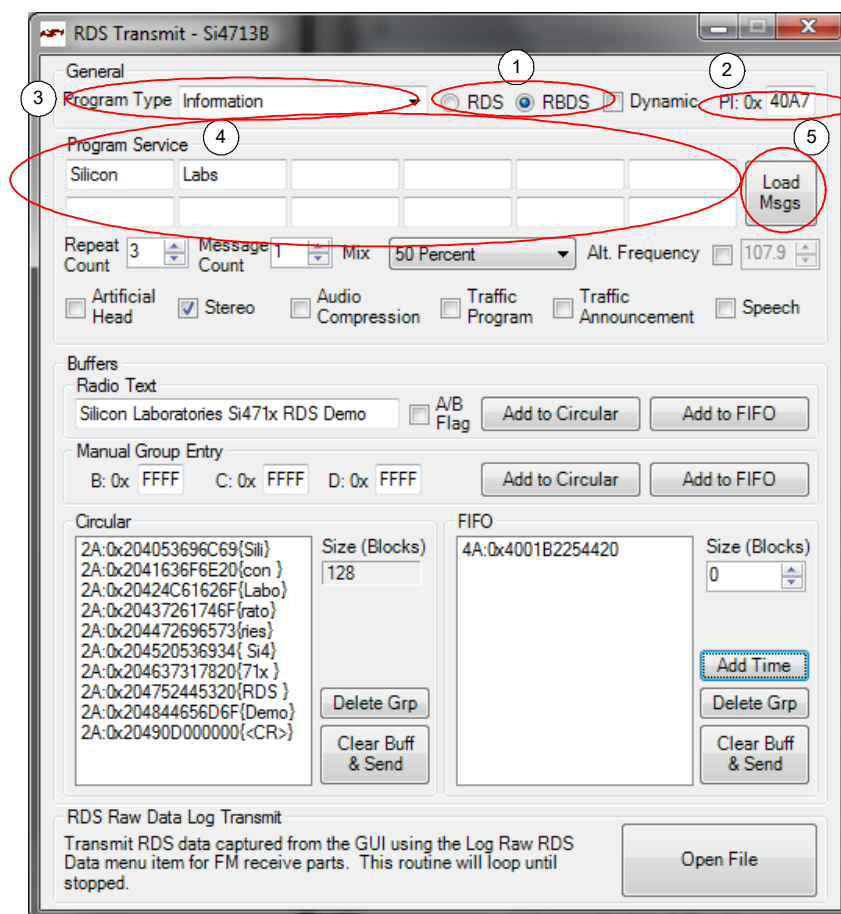

Figure 46. Basic RDS Message Illustration

1. First select whether you want to transmit in RDS format (Europe) or RBDS format (US).
2. Type in the Program Identification in this field. Program Identification is a 16-bit code assigned to an individual station.
3. Select the Program Type in the pull down menu here. Some examples include news, information, sports, talk, rock, etc.
4. Enter the Program Service (PS) in the boxes provided. You can enter a maximum of 12 different PS messages, in which each PS message can contain a maximum of 8 characters.
 - a. Repeat Count: Enter how many times you want each PS message to be transmitted before sending the next PS message.
 - b. Message Count: Enter how many of the 12 PS messages that you actually want to transmit.
 - c. Mix: Select 100 percent.
5. Click Send Message button here. Now the RDS will transmit the PS message along with the PI and PTY. You should see these data in your RDS receiver.

5.10.2. Intermediate

In the intermediate section, we will cover the buffers category of sending the RDS data with the device, in particular we will send Group Type 2 (Radio Text) and Group Type 4 (Clock Time).

The following diagram shows a step-by-step procedure to send the buffers data in addition to the General and Program Service data covered in the basic section.

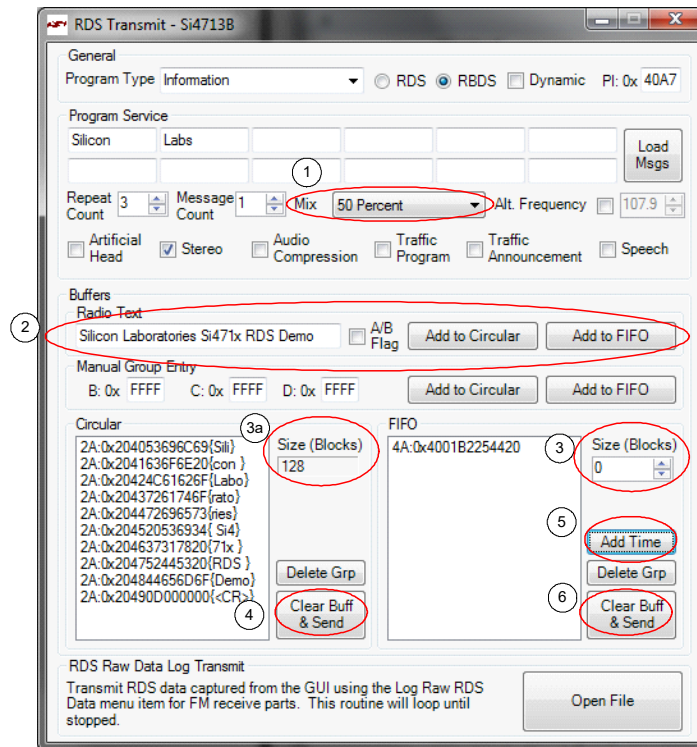

Figure 47. Intermediate RDS Message Illustration

1. Select the Mix percentage that you want between transmitting the data in Program Service and the data in the Buffers. A mix percentage of 100% means that you will always transmit the PS message regardless of what is contained in the Buffers, whereas a mix percentage of 0% means that you will always transmit the data in the Buffers regardless of what is contained in the PS. If the buffers are empty, the PS messages will be transmitted all the time regardless of the mix percentage.
2. Enter the Radio Text message that will be transmitted. After entering the RT message, click either the "Add to Circular" button or the "Add to FIFO" button. The RT message will be encoded according to the RDS Group Type 2 rule.
 - a. Clicking "Add to Circular" button means that you add the RT message into the GUI Circular Buffer queue. Note that the message itself has not been uploaded into the Circular Buffer inside the device until the Clear Buff & Send is clicked.
 - b. Clicking "Add to FIFO" means that you upload the RT message into the GUI FIFO Buffer queue. Note that the message itself has not been uploaded into the FIFO Buffer inside the device until the Clear Buff & Send is clicked.
3. Enter the size of the FIFO that you want here. The device buffer has a total of 128 blocks, which is shared by the circular buffer and the FIFO. Therefore, the circular buffer size (shown in 3a) will be the remainder of the 128 blocks minus the FIFO size.
4. Clicking this "Clear Buff & Send" button will upload the message from the GUI Circular Buffer queue into the Circular Buffer inside the device. The Circular Buffer on the part will repeatedly send the message contained in the buffer. Note that the messages in the circular buffer will be transmitted only if the PS Mix value is set to anything other than 100%.

Si47xx-EVB

5. Clicking the "Add Time" button here will add the current time as a RDS Group Type 4 message to the GUI FIFO Buffer queue.
6. Clicking the "Clear Buff & Send" button will upload the message from the FIFO Buffer Indicator Window into the FIFO Buffer inside the device. The FIFO Buffer on the part will only send the messages contained in the buffer once. A good example of using FIFO buffer is when you want to send the time data. Time is something that occurs only once, so it will not be beneficial to upload time to the circular buffer and transmit it continuously. Refer to step 5 for information on sending time data. Note that the messages in the FIFO buffer will be transmitted only if the PS Mix value is set to anything other than 100%.

5.10.3. Advanced

In the advanced section, we will cover the remaining RDS topics.

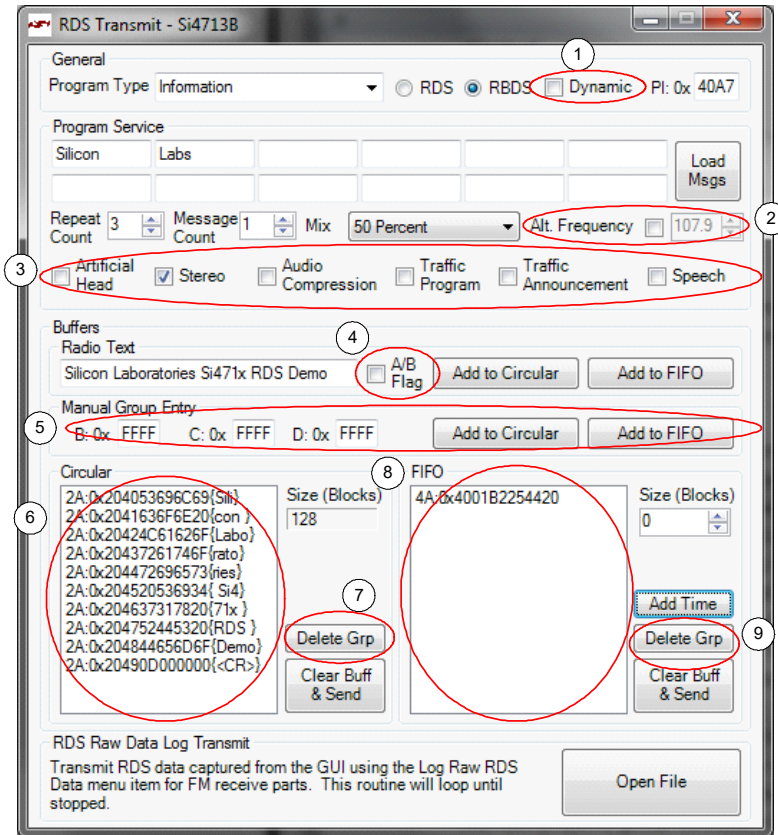

Figure 48. Advanced RDS Sending Illustration

1. Dynamic: This tells whether the PTY code is static or dynamic.
2. Alternate Frequency: This provides the ability to inform the receiver of a single alternate frequency. This field is transmitted along with the Group Type 0 (PS).
3. Miscellaneous bits in Group Type 0 (PS):
 - a. Artificial Head: 0 = Not Artificial Head; 1 = Artificial Head
 - b. Stereo: 0 = Mono; 1 = Stereo
 - c. Audio Compressor: 0 = Not compressed; 1 = Compressed
 - d. Traffic Program (TP): 0 = No TP; 1 = TP
 - e. Traffic Announcement (TA): 0 = No TA; 1 = TA
 - f. Speech: 0 = Speech; 1 = Music
4. A/B Flag: This is an important flag in the RDS Group Type 2 (RT). Checking this box when a Radio Text is

uploaded means that the RT is uploaded with the flag set. Un-checking this box when an RT is uploaded means that the flag is not set. This flag tells the receiver that when the flag toggles from set to reset or vice versa, the receiver will clear the display before showing the next RT.

5. **Manual Group Entry:** Use this box to upload the RDS data manually. You can use this box to upload messages from the Group Type for which the GUI does not have encoding support. For these messages, the user must encode the messages into hexadecimal code.
6. **Circular Buffer Indicator:** This displays the message that gets uploaded into the Circular Buffer in hexadecimal code. This can be useful to see how the Group Type 0 (PS), Type 2 (RT), and Type 4 (CT) is encoded into RDS data.
7. **Delete Circular Buffer Group:** This deletes a group that is selected in the Circular Buffer Indicator.
8. **FIFO Buffer Indicator:** This displays the message that gets uploaded into the FIFO buffer in hexadecimal code.
9. **Delete FIFO Buffer Group:** This deletes a group that is selected in the FIFO Buffer Indicator.

Si47xx-EVB

5.11. FM Transmitter Register Map Window

The register map window allows the user to manually program the device by sending commands to the chip. Refer to “AN332: Si47xx Programming Guide” to manually program the device. Clicking on Window→Register Map will launch the Register Map Window as shown in Figure 49.

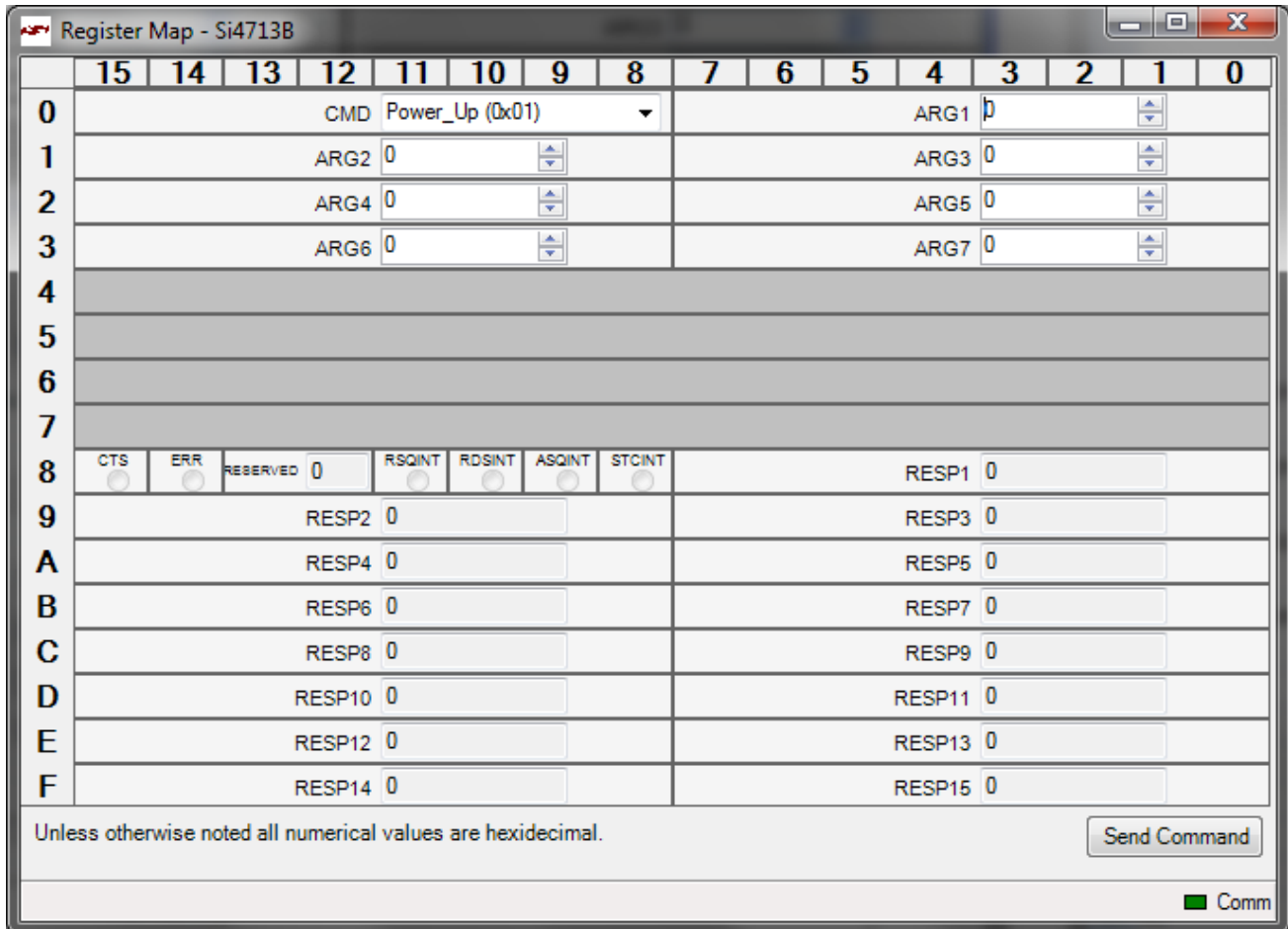

Figure 49. FM Transmitter Register Map Window

6. FM Receiver GUI

The first Si47xx window is the Initialization window as shown in Figure 50.

Select the FM receiver function.

As an FM receiver, analog audio out is available on pins 13 and 14.

6.1. Configuring the Si47xx as an FM Receiver

Select the device, busmode, firmware revision, and initial part settings and then click Initialize. A new window displaying "Initializing FM Receiver" will appear. If you check "Use XOSCEN," the daughtercard crystal and on-chip oscillator will be used to clock the Si47xx. Crystal operation is not supported on Si474x-EVB (that supports Si4740/41/42/43/44/45) and Si4749-EVB. You can use the EVB Audio Settings drop down box to select the audio mode used by the Si47xx part. See Section 2.1.4 of the Si47xx-EVB User's Guide for more information on this setting. The Si4749 can also be programmed as an RDS only tuner. This selection is available through the EVB Audio Setting drop down box as well.

Note: As of February 2011, SPDIF is not supported on new EVBs. Modes of operation requiring the SPDIF will not be available in the initialization window for those boards.

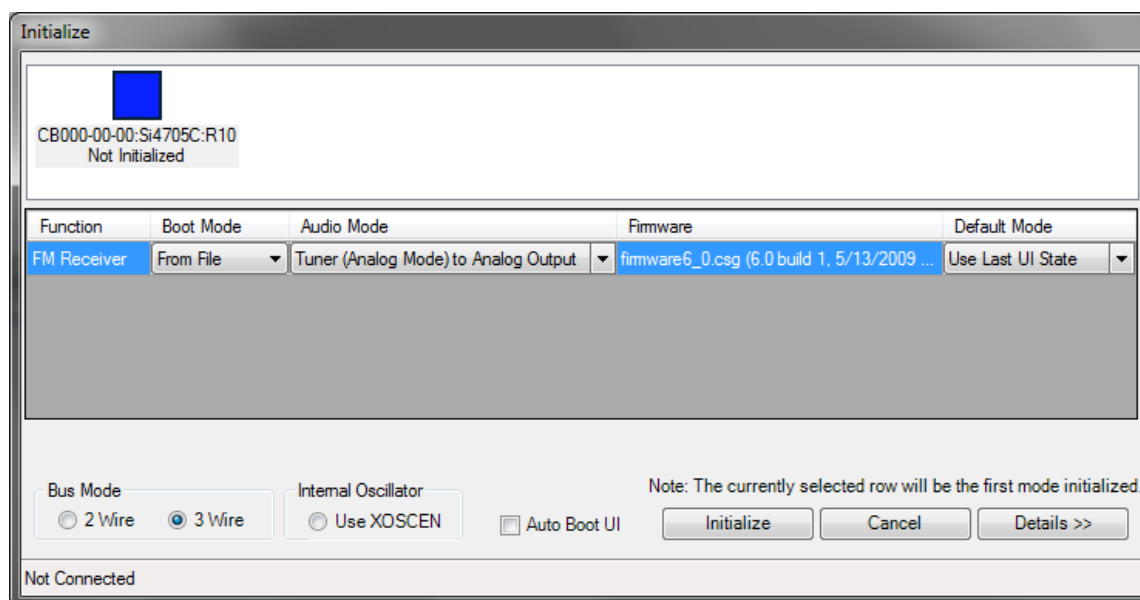

Figure 50. FM Receiver Initialization

Si47xx-EVB

6.2. FM Receiver Main Window

The FM receiver main window will appear after initialization.

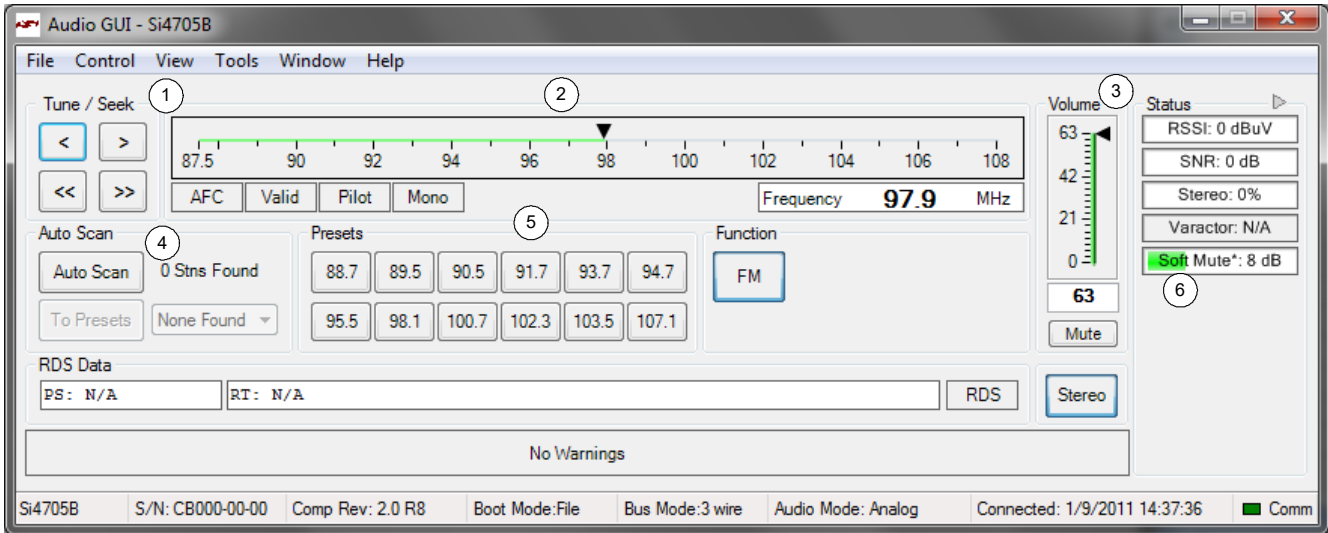

Figure 51. FM Receiver Main Window

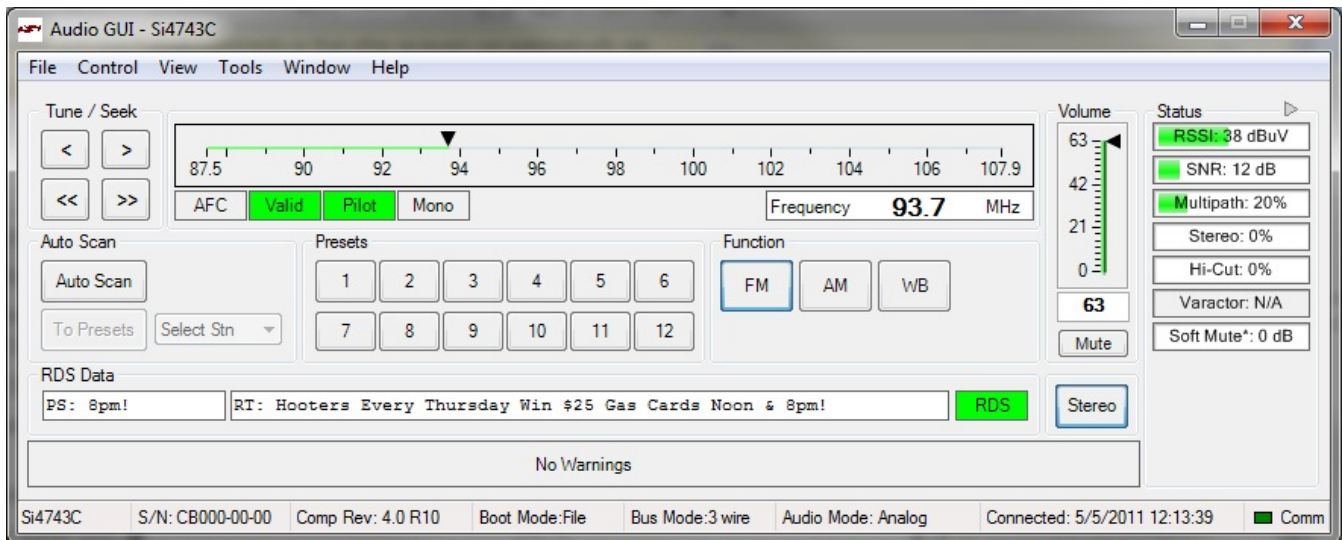

Figure 52. FM Receiver Main Window for Si474x

Table 14. FM Receiver Main Window Descriptions

#	Name	Descriptions
1	Tune/Seek	Tune Down (<), Tune Up (>) buttons execute a single channel step according to the channel spacing setting. The channel spacing setting can be set in the property window.
		Seek down (<<), Seek Up (>>) buttons execute a seek up or down to the next received FM signal meeting or exceeding the seek settings within the selected band. The seek setting Received Signal Strength Indicator (RSSI) and Signal to Noise Ratio (SNR) threshold can be set in the property window.
2	Freq Slider, AFC Rail Indicator, Mono/Stereo Indicator, Pilot Indicator, Stereo Blend Indicator, Valid Indicator	The Frequency Display indicates the frequency in MHz. To change the Frequency, drag the pointer in the Frequency Slider Bar to the desired frequency. The frequency may also be changed by changing the value in the display.
		AFC Rail indicator will be red if the tuned frequency is in an AFC rail state, otherwise the indicator will be grey.
		The Mono/Stereo indicator will switch to stereo if the blend ratio is greater than 0 and the Pilot is present.
		The Pilot indicator will be green if the received FM signal has a pilot signal.
		The Stereo Blend indicator will be green if the part goes into linear blend between stereo and mono. Full mono is indicated by 0% and full stereo is indicated by 100%.
		The Valid indicator will be green if the FM frequency meets the RSSI and SNR seek settings in the property window.
3	Volume, Mute	Select the Si47xx output volume (0-63) by moving the slider bar pointer. Press the Mute button to mute the Si47xx radio. If the radio is muted, the button will be red. Press the Mute button again to remove the muting.
4	Auto Scan, To Preset, Select Stn	The Auto Scan button will find all the stations with an RSSI and SNR above the seek settings in the property window. After the scan is completed, the number of stations found will be displayed and each station will be available in the drop down box. Also, a red indicator mark will be displayed on the Frequency Slider Bar (2) for each station. The "To Presets" Button will program the preset buttons (5) with the 12 strongest stations.
5	Presets	Press the desired button to tune to the frequency displayed on the button. To store a new value to the preset button, tune to the desired frequency and then press and hold the desired button for 1.5 seconds. The button will then change to indicate the stored frequency.
6	RSSI/SNR/ Multipath/Stereo/Hi- Cut/SoftMute	The RSSI indicator displays the RSSI of the signal in dBuV.
		The SNR indicator displays the SNR of the received signal in dB.
		The Multipath indicator will be green if Multipath is detected. This indicator is only available in Si474x products. Refer to Figure 60.
		The Stereo Blend indicator will be green if the part goes into linear blend between stereo and mono. Full mono is indicated by 0% and full stereo is indicated by 100%.
		The Hi-Cut indicator will indicate the percentage of hi-cut being applied to the audio signal. This indicator is only available in Si4742/43/44/45 products. Refer to Figure 60.
		The Soft Mute indicator will indicate the amount of attenuation in dB applied to the audio signal.

Si47xx-EVB

6.3. FM Receiver Settings Property Window

FM receiver settings can be configured through the properties window by selecting Window→Properties. Properties are grouped into categories which can be selected from the drop-down box in the upper right of the window. For convenience, all FM receiver properties are also located in Window→Properties→FM: All.

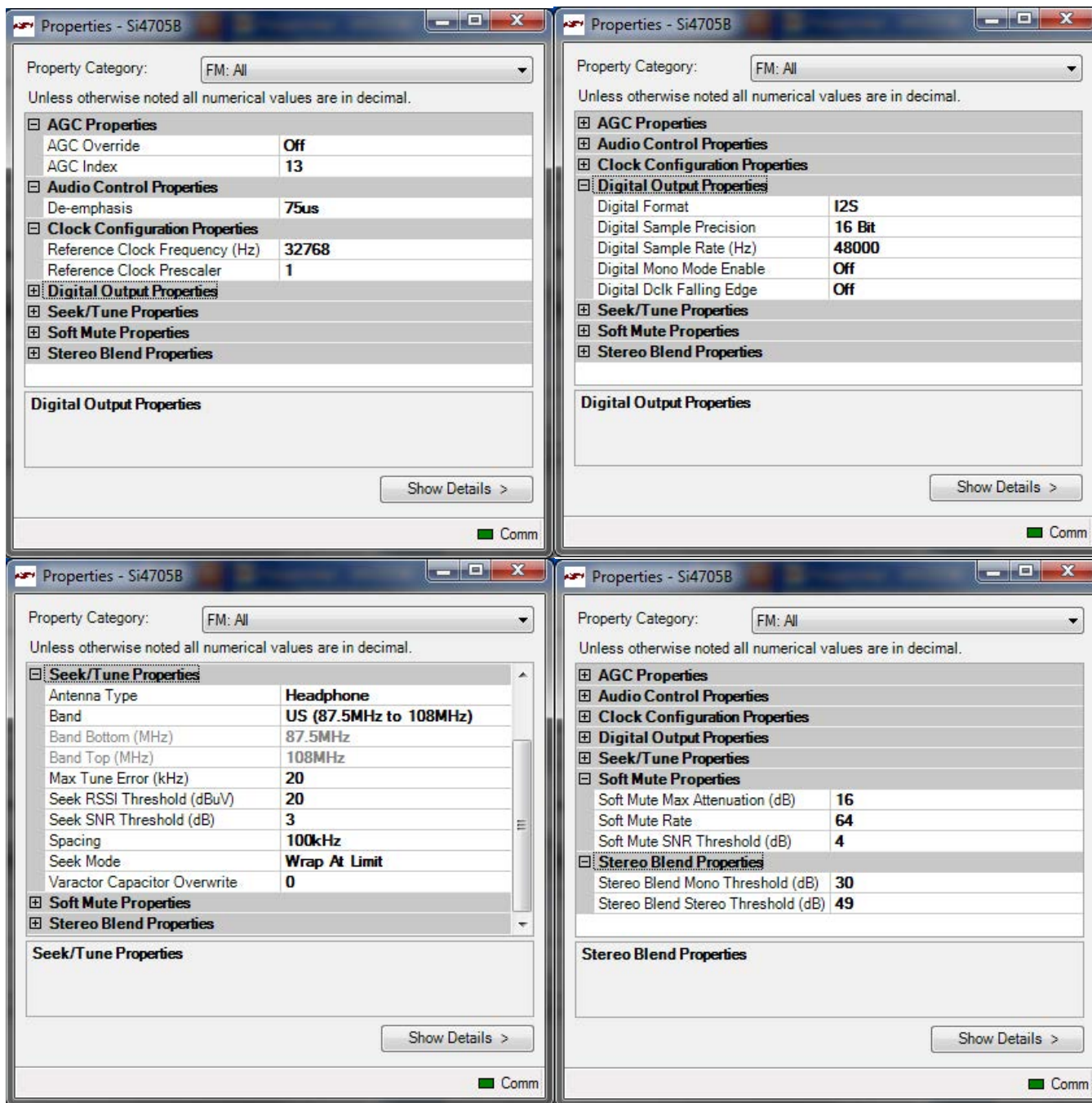

Figure 53. FM Receiver Settings Property Window

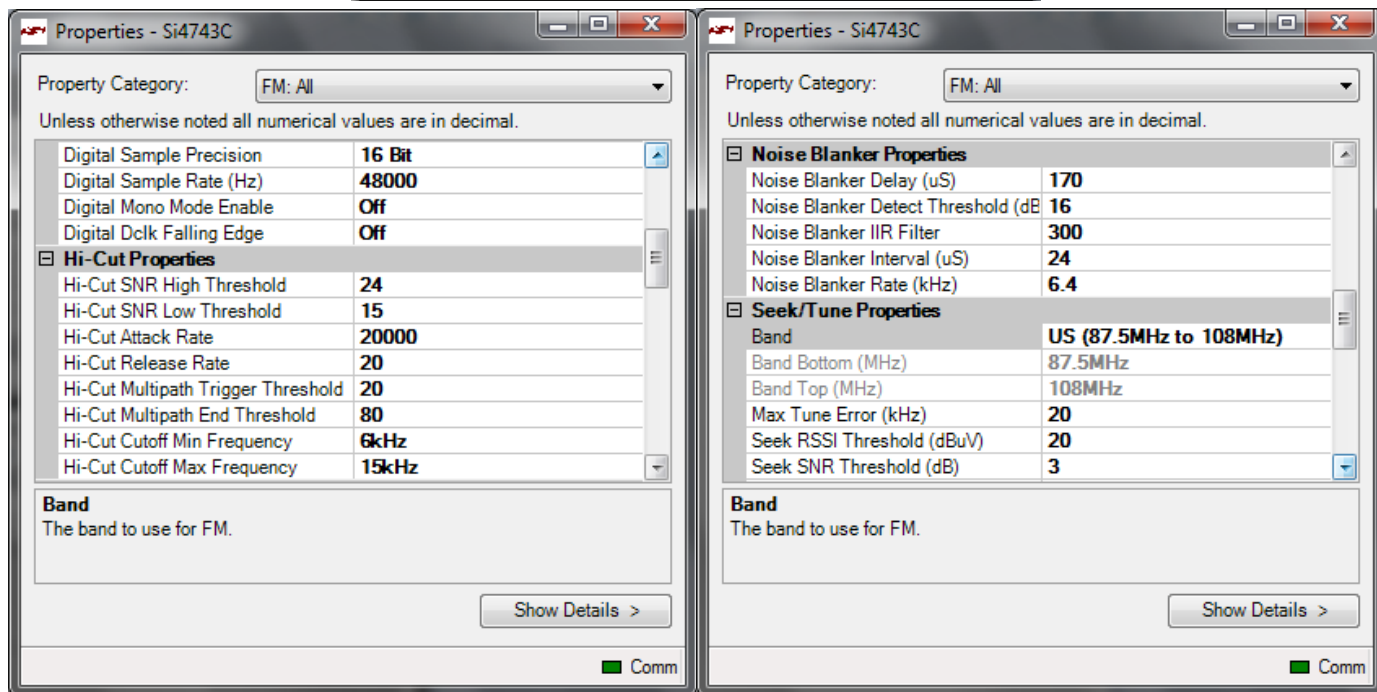
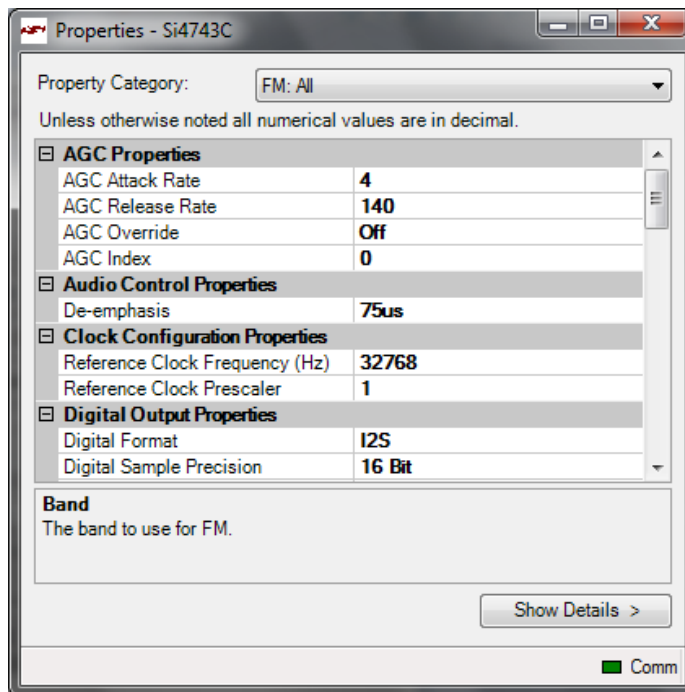

Figure 54. FM Receiver Setting Property Window for Si474x (1 of 2)

Si47xx-EVB

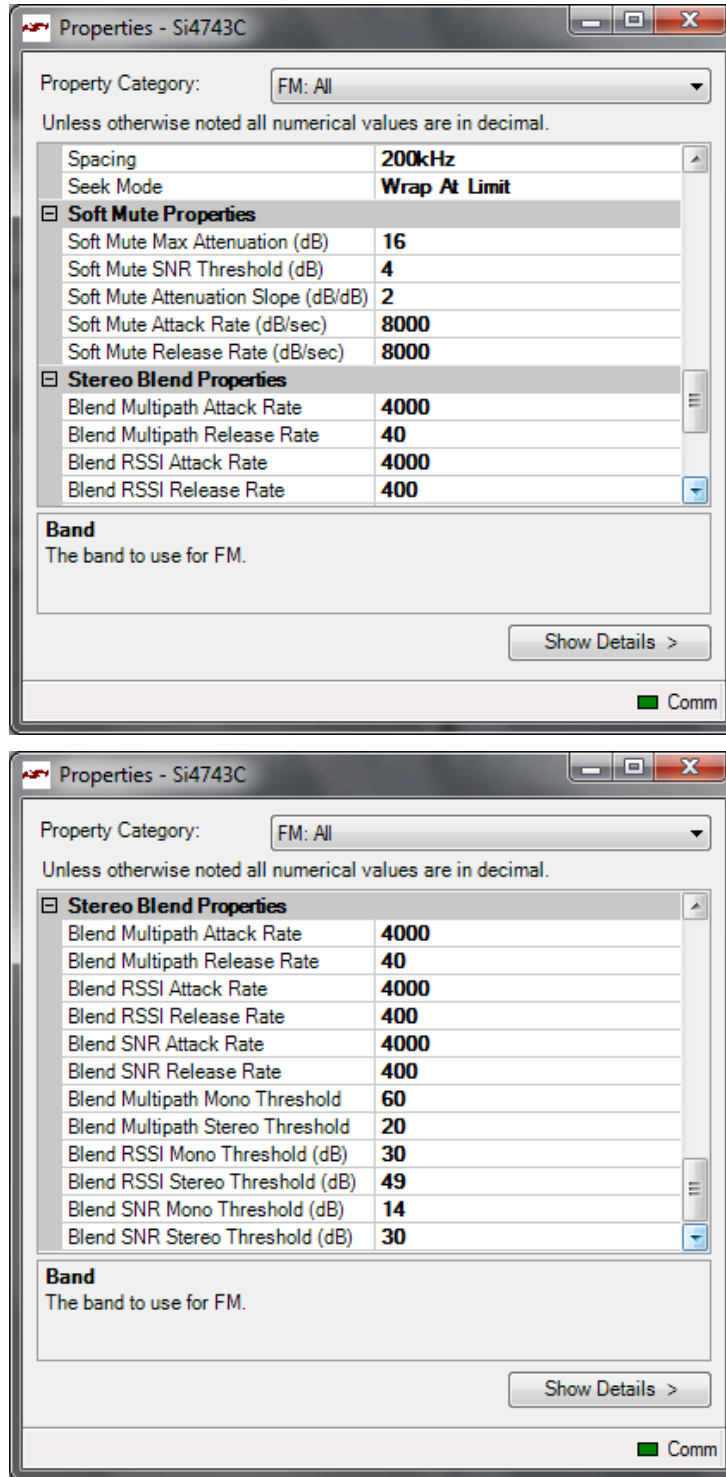

Figure 55. FM Receiver Setting Property Window for Si474x continued (2 of 2)

Table 15. FM Receiver Settings Property Window Descriptions

Items	Description	Range	Applicable Devices
AGC Attack Rate	Larger values provide slower attack and smaller values provide faster attack.	4–248	Si474x
AGC Index	If AGC override is set to “ON,” this property will determine the AGC setting.	0–26	All
AGC Override	If set to “ON,” the AGC property will be used to set the value of the AGC. If set to “OFF,” the AGC setting will be automatically determined by the part.	ON/OFF	All
AGC Release Rate	Larger values provide slower release and smaller values provide faster release.	4–248	Si474x
De-emphasis	Selects de-emphasis of 50 μ s or 75 μ s.	50 μ s, 75 μ s	All except Si4749
Reference Clock Frequency (Hz)	This field is used to specify the frequency of the reference clock. The input to the RCLK pin divided by the prescaler is the reference clock. The reference clock must be in the range of 31130 to 34406 Hz.	31130– 34406 Hz	All
Reference Clock Prescaler	This field is used to specify the prescaler value. The input to the RCLK pin divided by the prescaler is the reference clock. The reference clock must be in the range of 31130 to 34406 Hz.	1–4095 Hz	All
Digital DCLK Falling Edge	ON uses falling edge of DCLK for sampling.	ON, OFF	Si4705/06, Si4721/31/35/37/39, Si4730/34/36/38-D60 and later, Si4741/43/45, Si4784/85
Digital Format	Format of digital audio output.	I2S, Left-Justified, DSP	Si4705/06, Si4721/31/35/37/39, Si4730/34/36/38-D60 and later, Si4741/43/45, Si4784/85
Digital Mono Mode Enable	ON enables mono in digital audio output.	ON, OFF	Si4705/06, Si4721/31/35/37/39, Si4730/34/36/38-D60 and later, Si4741/43/45, Si4784/85

Si47xx-EVB

Table 15. FM Receiver Settings Property Window Descriptions (Continued)

Items	Description	Range	Applicable Devices
Digital Sample Precision	Digital audio output bit precision.	8-bit, 16-bit, 20-bit, 24-bit	Si4705/06, Si4721/31/35/37/39, Si4730/34/36/38-D60 and later, Si4741/43/45, Si4784/85
Digital Sample Rate Hz	DFS sample rate for digital input signal. Recommended values are: 32 kHz, 44.1 kHz, or 48 kHz. Over-sampling rate must be set in order to satisfy a minimum DCLK of 1 MHz. Sample rate must be set to 0 before DCLK/DFS is removed.	0, 32000–48000 Hz	Si4705/06, Si4721/31/35/37/39, Si4730/34/36/38-D60 and later, Si4741/43/45, Si4784/85
Hi-Cut Attack Rate	Set the rate at which hi-cut lowers the cutoff frequency. If set to 0, hi-cut attack is disabled.	0 - 32767	Si4740/41/42/43/44/45, Si4704/05-D50 and later, Si4706-C30 and later, Si4730/31/34/35/84/85-D50 and later
Hi-Cut Cutoff Max Frequency	Sets the maximum audio transition frequency bandwidth.	Disabled, 2, 3, 4, 5, 6, 8, and 11 kHz	Si4740/41/42/43/44/45, Si4704/05-D50 and later, Si4706-C30 and later, Si4730/31/34/35/84/85-D50 and later
Hi-Cut Cutoff Min Frequency	Sets the minimum band limit transition frequency for hi-cut.	Disabled, 2, 3, 4, 5, 6, 8, and 11 kHz	Si4740/41/42/43/44/45, Si4704/05-D50 and later, Si4706-C30 and later, Si4730/31/34/35/84/85-D50 and later
Hi-Cut Multipath End Threshold	Sets the multipath level at which hi-cut reaches maximum limit.	0 -100	Si4740/41/42/43/44/45, Si4704/05-D50 and later, Si4706-C30 and later, Si4730/31/34/35/84/85-D50 and later
Hi-Cut Multipath Trigger Threshold	Sets the multipath level at which hi-cut begins to band limit.	0 -100	Si4740/41/42/43/44/45, Si4704/05-D50 and later, Si4706-C30 and later, Si4730/31/34/35/84/85-D50 and later
Hi-Cut Release Rate	Set the rate at which hi-cut increases the cutoff frequency. If set to 0, hi-cut release is disabled.	0 - 32767	Si4740/41/42/43/44/45, Si4704/05-D50 and later, Si4706-C30 and later, Si4730/31/34/35/84/85-D50 and later

Table 15. FM Receiver Settings Property Window Descriptions (Continued)

Items	Description	Range	Applicable Devices
Hi-Cut SNR High Threshold	Sets the SNR level at which hi-cut begins to band limit.	0 – 127 dB	Si4740/41/42/43/44/45, Si4704/05-D50 and later, Si4706-C30 and later, Si4730/31/34/35/84/85-D50 and later
Hi-Cut SNR Low Threshold	Sets the SNR level at which hi-cut reaches maximum band limit.	0–127 dB	Si4740/41/42/43/44/45, Si4704/05-D50 and later, Si4706-C30 and later, Si4730/31/34/35/84/85-D50 and later
Noise Blanker Delay	Delay in microseconds before applying noise blanking to the original samples.	125–219 μ s	Si4742/43/44/45
Noise Blanker Detect Threshold	Sets the threshold for detecting impulses in dB above the noise floor. If set to 0, impulse noise blanking is disabled.	0 – 90 dB	Si4742/43/44/45
Noise Blanker IIR Filter	Sets the cut-off frequency for the low pass filter that is used for noise floor estimation in noise blanker detection.	300–1600	Si4742/43/44/45
Noise Blanker Interval	Interval original samples are replaced by interpolated clean samples.	8 – 48 μ s	Si4742/43/44/45
Noise Blanker Rate	Maximum noise blanking rate.	100 – 6400 Hz	Si4742/43/44/45
Antenna Type	Receive antenna selection.	Headphone or short antenna	Si4704/05/06/20/21 only
Channel Filter	Selects the channel filter to be used before demodulation.	Automatic, 110 kHz, 84 kHz, 60 kHz, and 40 kHz	Si4706, Si4749, Si4704/05/30/31/34/35/84/85-D50 and later
Band	Frequency band	US/Europe: 87.5–108 MHz Japan: 76–90 MHz Japan Wide: 76–108 MHz	All
Seek Band Bottom (MHz)	The lower frequency limit for the seek function. This is set automatically by the GUI based on band and spacing selection.	US/Europe: 87.5 MHz Japan: 76 MHz Japan Wide: 76 MHz	All

Si47xx-EVB

Table 15. FM Receiver Settings Property Window Descriptions (Continued)

Items	Description	Range	Applicable Devices
Seek Band Top (MHz)	The upper frequency limit for the seek function. This is set automatically by the GUI based on band and spacing selection.	US: 107.9 MHz (200 kHz spacing) Europe: 108 MHz (100 kHz spacing) Japan: 90 MHz Japan Wide: 108 MHz	All
Max Tune Error (kHz)	Selects the maximum tuning frequency error before the AFC rail indicator is set.	0–255 kHz	All
Seek Mode	Select between stopping the seek at the band limits or wrapping at the band limits to return to the starting frequency.	Stop at limit or wrap at limit	All
Seek RSSI Threshold (dBuV)	The seek RSSI threshold level used for seek and scan functions.	0–255 dB	All
Seek SNR Threshold (dB)	The seek SNR threshold level used for seek and scan functions.	0–255 dB	All
Spacing	Channel spacing	50, 100, or 200 kHz	All
Soft Mute Attack Rate (dB/s)	Sets the attack rate for entering soft mute.	1–31999 dB/s	Si4706-C30 and later, Si4740/41/42/43/44/45, Si4704/05/30/31/34/35/84/85-D50 and later
Soft Mute Attenuation Slope (dB/dB)	Soft mute attenuation slope specifies the slope of the attenuation curve when the signal SNR is below the soft mute SNR threshold. It is specified as dB/dB where the attenuation applied is simply the value specified here times the amount the signal SNR is below the threshold.	1–63	Si4704/05/06/3x-C40 and later, Si4740/41/42/43/44/45
Soft Mute Max Attenuation (dB)	Maximum attenuation for soft mute.	0–31 dB, 0 = disable soft mute	All except Si4749
Soft Mute Release Rate (dB/s)	Sets the release rate for leaving soft mute.	1–31999 dB/s	Si4706-C30 and later, Si4740/41/42/43/44/45, Si4704/05/30/31/34/35/84/85-D50 and later
Soft Mute SNR Threshold (dB)	SNR threshold level used to engage soft mute.	0–15 dB	All except Si4749
Soft Mute Rate	Selects the soft mute rate.	1–255 dB	Si4706/07/20/21/84/85-B20 and earlier, Si4704/05/30/31/34/35-C40 and earlier

Table 15. FM Receiver Settings Property Window Descriptions (Continued)

Items	Description	Range	Applicable Devices
Blend Multipath Attack Rate	Attack rate associated with multipath when adjusting blend. If set to 0, attack would be disabled.	0–32767	Si4740/41/42/43/44/45, Si4704/05-D50 and later, Si4706-C30 and later, Si4730/31/34/35/84/85-D50 and later
Blend Multipath Mono Threshold	Multipath input level above which the tuner blends into full mono.	0–100	Si4740/41/42/43/44/45, Si4704/05-D50 and later, Si4706-C30 and later, Si4730/31/34/35/84/85-D50 and later
Blend Multipath Release Rate	Release rate associated with multipath when adjusting blend. If set to 0, release would be disabled.	0–32767	Si4740/41/42/43/44/45, Si4704/05-D50 and later, Si4706-C30 and later, Si4730/31/34/35/84/85-D50 and later
Blend Multipath Stereo Threshold	Multipath input level below which the tuner blends into full stereo.	0–100	Si4740/41/42/43/44/45, Si4704/05-D50 and later, Si4706-C30 and later, Si4730/31/34/35/84/85-D50 and later
Blend RSSI Attack Rate	Attack rate associated with RSSI when adjusting blend. If set to 0, attack would be disabled.	0–32767	Si4706-C30 and later, Si4740/41/42/43/44/45, Si4704/05/30/31/34/35/84/85-D50 and later
Blend RSSI Mono Threshold (dB)	RSSI level below which the tuner blends into full mono.	0–127 dB	Si4706-C30 and later, Si4740/41/42/43/44/45, Si4704/05/30/31/34/35/84/85-D50 and later
Blend RSSI Release Rate	Release rate associated with RSSI when adjusting blend. If set to 0, release would be disabled.	0–32767	Si4706-C30 and later, Si4740/41/42/43/44/45, Si4704/05/30/31/34/35/84/85-D50 and later
Blend RSSI Stereo Threshold (dB)	RSSI level above which the tuner blends into full stereo.	0–127 dB	Si4706-C30 and later, Si4740/41/42/43/44/45, Si4704/05/30/31/34/35/84/85-D50 and later
Blend SNR Attack Rate	Attack rate associated with SNR when adjusting blend. If set to 0, attack would be disabled.	0–32767	Si4740/41/42/43/44/45, Si4704/05-D50 and later, Si4706-C30 and later, Si4730/31/34/35/84/85-D50 and later
Blend SNR Mono Threshold (dB)	SNR level below which the tuner blends into full mono.	0–127 dB	Si4740/41/42/43/44/45, Si4704/05-D50 and later, Si4706-C30 and later, Si4730/31/34/35/84/85-D50 and later

Si47xx-EVB

Table 15. FM Receiver Settings Property Window Descriptions (Continued)

Items	Description	Range	Applicable Devices
Blend SNR Release Rate	Release rate associated with SNR when adjusting blend. If set to 0, release would be disabled.	0–32767	Si4740/41/42/43/44/45, Si4704/05-D50 and later, Si4706-C30 and later , Si4730/31/34/35/84/85-D50 and later
Blend SNR Stereo Threshold (dB)	SNR level above which the tuner blends into full stereo.	0–127 dB	Si4740/41/42/43/44/45, Si4704/05-D50 and later, Si4706-C30 and later , Si4730/31/34/35/84/85-D50 and later
Stereo Blend Mono Threshold (dB)	RSSI threshold below which the tuner blends into full mono.	0–127 dB	Si4704/05/1x/2x/3x-C40 or earlier, and Si4706-B20
Stereo Blend Stereo Threshold (dB)	RSSI threshold above which the tuner blends into full stereo.	0–127 dB	Si4704/05/1x/2x/3x-C40 or earlier and Si4706-B20

6.4. CODEC and SPDIF Settings

Si47xx-EVB baseboard has a Codec and an SPDIF translator for digital audio output. For tuners with digital audio option, you can set properties for the Codec and SPDIF through the GUI. These settings can be used with AM or FM tuners that have digital audio enabled.

Select Window→Properties→CODEC and SPDIF Settings.

Note: SPDIF will not be supported on new EVBs as of February 14, 2011. SPDIF properties will not be available through the GUI in conjunction with those boards. CODEC properties will be available through Window→Properties→CODEC Settings.

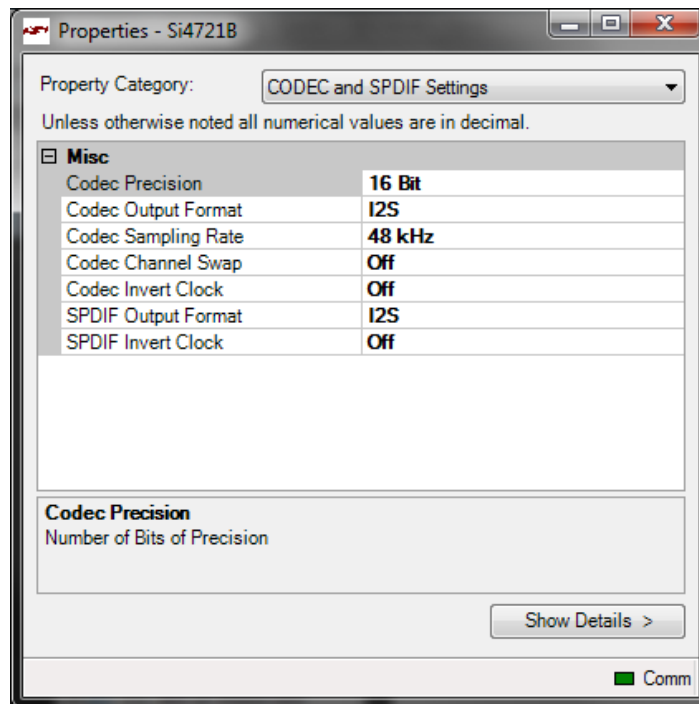

Figure 56. CODEC and SPDIF Settings Window

Table 16. CODEC and SPDIF Settings Windows Descriptions

Items	Description	Range
Misc.		
Codec Precision	Precision of the CODEC on baseboard in bits.	16-bit, 20-bit, 24-bit
Codec Output Format	Format of audio output through the Codec.	I ² S, Left-Justified, DSP(MSB on 1 st DCLK), DSP(MSB on 2nd DCLK)
Codec Sampling Rate	Sampling rate for the Codec in kHz.	32 kHz, 48 kHz
Codec Channel Swap	Determines if channels need to be swapped on the Codec.	ON, OFF
Codec Invert Clock	ON inverts the digital clock.	ON, OFF
SPDIF Output Format	Format of audio output through the SPDIF.	I ² S, Left-Justified
SPDIF Invert Clock	ON inverts the digital clock.	ON, OFF

Si47xx-EVB

6.5. FM Receiver RDS Window

The FM receive RDS window allows the user to view program service, program type, PI code, radio text, enhanced radio text, radio text plus, clock, group error rate, sync time and display times, an alternate frequency list, and group statistics. Select Window→RDS Receive Data. Click on Radio Text Plus (RT+) to get the RT+ class and item information.

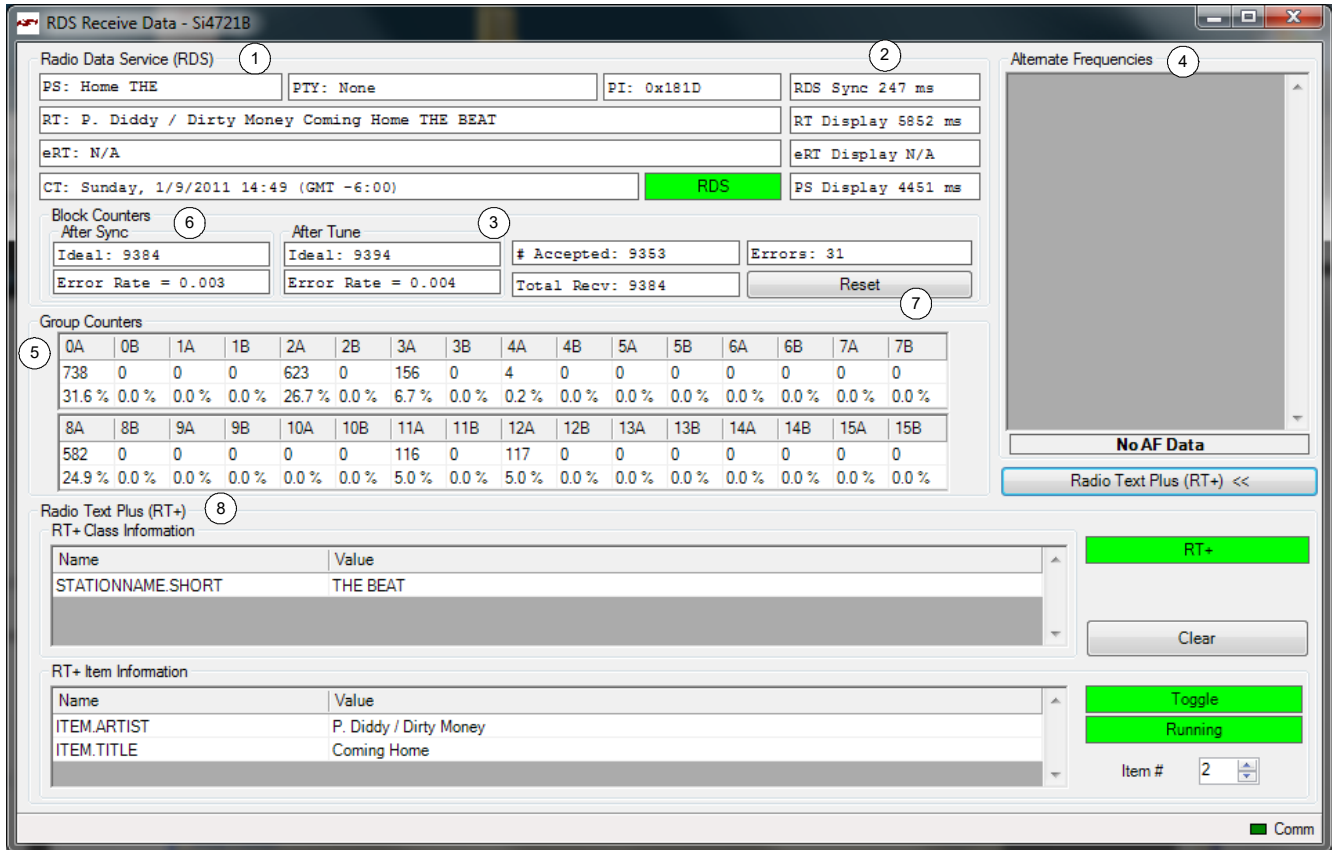

Figure 57. FM Receiver Settings RDS Window

Table 17. FM Receiver Settings RDS Window Descriptions

#	Items	Description
1	Radio Data Service	PS: Program Service Indicator (8 characters).
		RT: Radio Text Indicator (64 characters).
		eRT: Enhanced Radio Text Indicator
		CT: Clock Indicator showing time, day, and date.
		Group Error Rate indicates the percentage of uncorrectable groups received.
		PTY: Program Type Indicator
		PI: PI Code Indicator
2	Sync Times	Time required to synchronize, display radio text, and display program service.
3	RDS Synchronization Indicator	Indicates that RDS is synchronized.
4	Alternate Frequency Indicator	When present, shows a list of alternate frequencies. Alternate frequency methods A and B are supported.
5	Group Counters	Provides the total number and percentage breakdown of group types 0–15, A/B. To view this information, select Window→RDS Group Counters. Please refer to Figure 58.
6	Block Counters	<p>Provides the block error rates after tune and after RDS Sync.</p> <p>After Tune Error Rate: After tune (STC interrupt), the ideal number of blocks the FM tuner should have received is calculated. Also, the number of accepted blocks and errors are calculated.</p> <p>Error Rate = number of errors / number of ideal blocks after tune.</p> <p>After Sync Error Rate: After RDS Sync (RDS interrupt), the ideal number of blocks the FM tuner should have received is calculated. Also, the number of accepted blocks and errors are calculated.</p> <p>Error Rate = number of errors / number of ideal blocks after sync</p> <p>Because it usually takes 100~200ms for the FM tuner to synchronize to RDS data (STC interrupt always comes before RDS interrupt), "After Tune Error Rate" will always be greater than "After Sync Error Rate." After a long time, both error rates should consolidate at similar levels.</p>
7	Reset	Resets the block counter numbers.
8	Radio Text Plus	Radio Text Plus (RT+) Class and Item Information Indicator

Si47xx-EVB

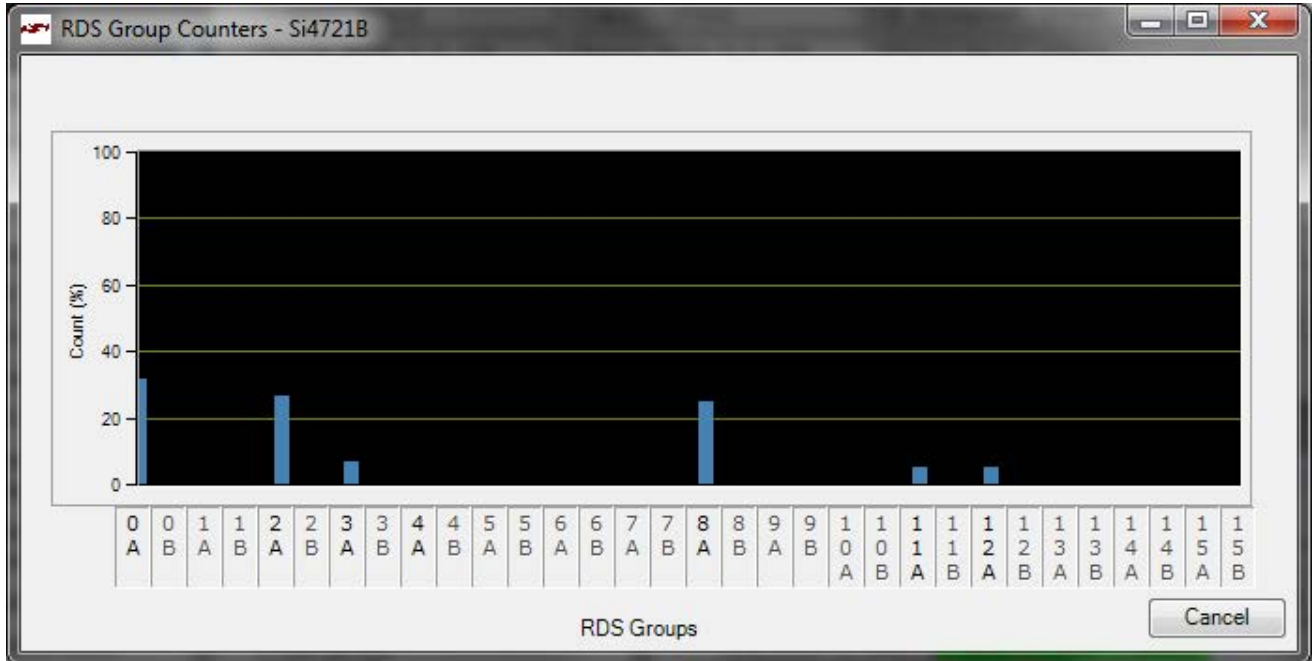

Figure 58. RDS Group Counters Window

6.6. FM Receiver RDS Settings

RDS settings are configured by selecting Window→Properties→FM Receiver RDS Settings.

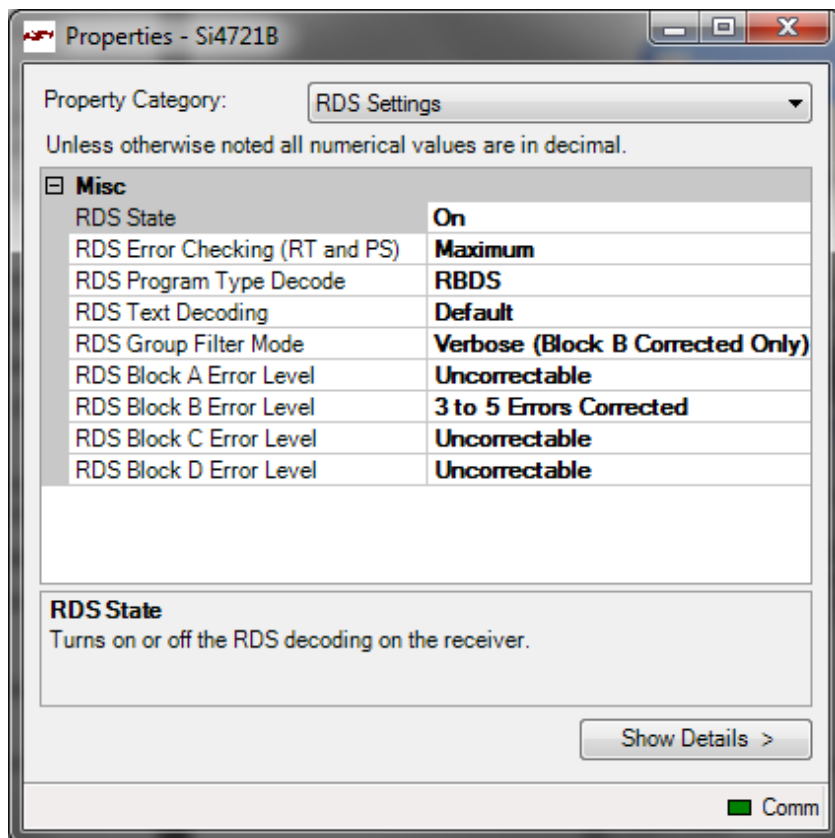

Figure 59. FM Receiver RDS Settings Window

Table 18. FM Receiver RDS Settings Window Descriptions

Item	Description	Range
Misc.		
RDS State	Enables and disables RDS.	On, Off
RDS Error Checking (RT and PS)	Selects GUI error checking level. Minimum displays text as received. Mid-range requires two duplicate buffers before displaying text. Maximum requires two duplicate buffers and also ignores the A/B flag.	Minimum, Mid-Range, Maximum
RDS Program Type Decode	Selects RDS or RBDS program type decoding.	RDS, RBDS
RDS Text Decoding*	Selects text decoding mode.	ASCII, Big 5 (Traditional Chinese), Default (Use system code page), UTF-8, Unicode
RDS Group Filter Mode	Selects group filter mode. Simple mode displays a group as long as all blocks are correctable. Verbose (Group B Uncorrected) mode displays a group even if one or more blocks is uncorrectable. Verbose (Group B Corrected) displays a group as long as block B is correctable, even if blocks A, C, or D are uncorrectable. Strict mode displays a group only if there are no errors in any block.	Simple, Verbose (Group B Corrected Only), Verbose (Group B Uncorrected), Strict
RDS Block A Error Level	Sets the Block A error level above which the entire RDS group will be discarded.	No Block Errors 1 to 2 errors corrected 3 to 5 errors corrected Uncorrectable
RDS Block B Error Level	Sets the Block B error level above which the entire RDS group will be discarded.	No Block Errors 1 to 2 errors corrected 3 to 5 errors corrected Uncorrectable
RDS Block C Error Level	Sets the Block C error level above which the entire RDS group will be discarded.	No Block Errors 1 to 2 errors corrected 3 to 5 errors corrected Uncorrectable
RDS Block D Error Level	Sets the Block D error level above which the entire RDS group will be discarded.	No Block Errors 1 to 2 errors corrected 3 to 5 errors corrected Uncorrectable
<p>*Note: The RDS character libraries are documented in Annex E of CENELEC EN 50067: 1998.</p>		

6.7. FM UI Settings

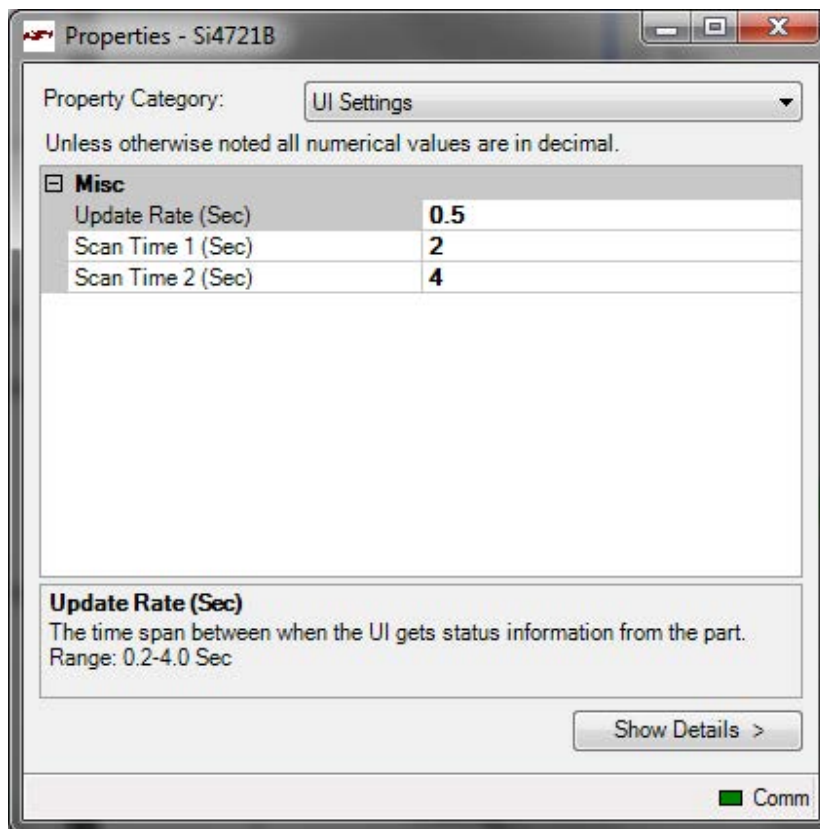

Figure 60. FM UI Settings Property Window

Table 19. FM UI Settings Property Window Descriptions

Hems	Description	Range
Misc.		
Update Rate (sec)	The time span when the UI gets status information from the part.	0.2–4.0 seconds
Scan Time 1 (sec)	In log band scan, the time between seeking and retrieving data from the UI.	1–10 seconds
Scan Time 2 (sec)	In log band scan, the time it takes the RDS data to populate, if RDS is available.	1–10 seconds

Note: UI settings window is common to all EVBs.

Si47xx-EVB

6.8. FM Receiver RSSI/SNR Graph Window

The RSSI/SNR Graph Window allows the user to plot RSSI and SNR across the FM band. Bitmap data can be saved to file by selecting File→Save as Bitmap and tabulated data can be saved to file by selecting File→Save to .csv.

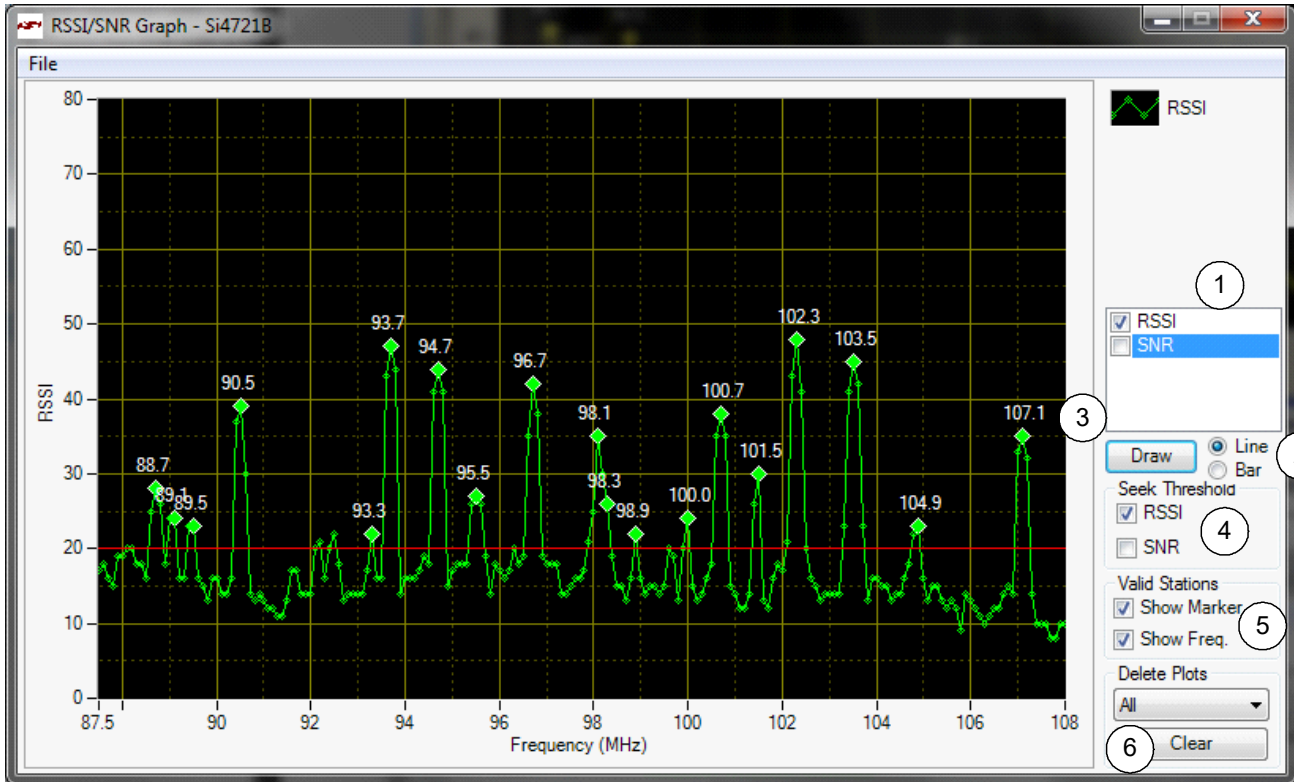

Figure 61. FM Receiver RSSI/SNR Graph Window

Table 20. FM Receiver RSSI/SNR Graph Window Descriptions

#	Items	Description
1	RSSI/SNR Graph	Select between drawing the RSSI, SNR graph, or both.
2	Line / Bar	Select between drawing in bar mode (depicted as green) or in continuous line mode (depicted as yellow).
3	Draw	Click this to start plotting the graph.
4	Seek Threshold (RSSI/SNR)	Draw the RSSI and/or SNR seek threshold as specified in the respective properties. The RSSI seek threshold is shown in red, the SNR seek threshold is shown in orange.
5	Valid Stations	Mark valid stations based on the RSSI/SNR seek threshold settings. Valid frequencies can also be marked.
6	Clear	Click this button to clear the traces selected in the Delete Plots combo box.

6.9. FM Receiver Register Map Window

The register map window allows the user to manually program the device by sending commands to the device. Refer to "AN332: Si47xx Programming Guide" to manually program the device.

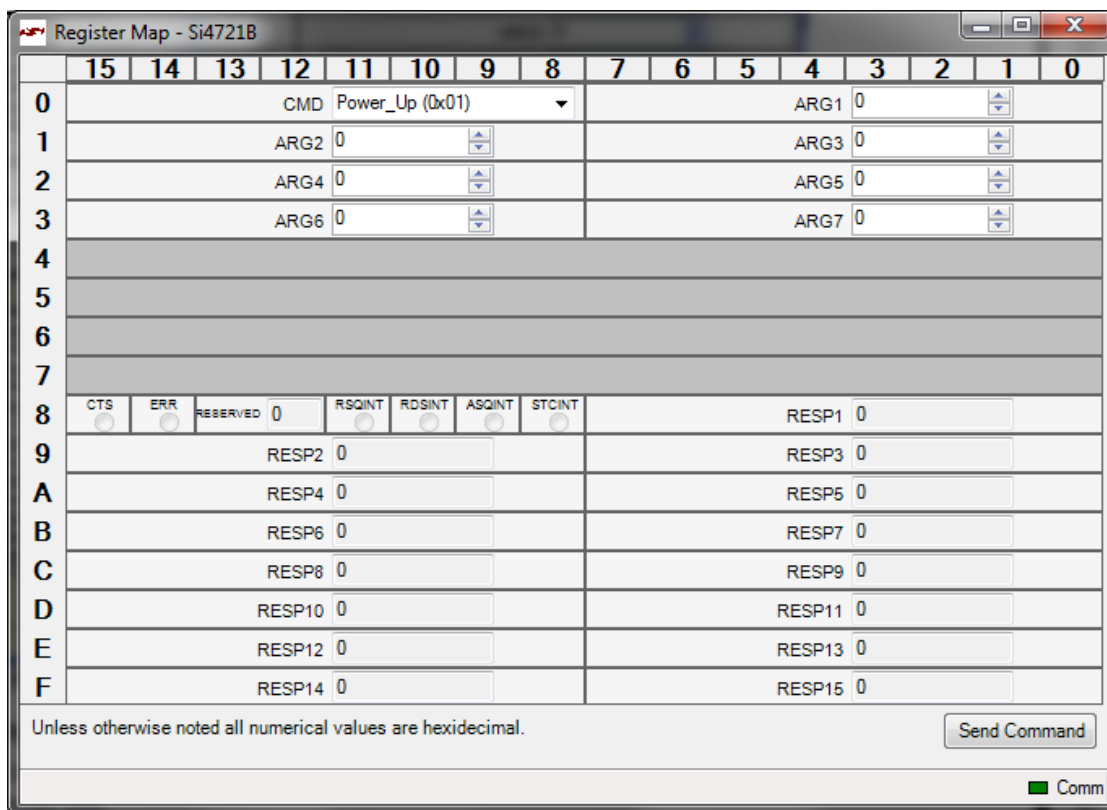

Figure 62. FM Receiver Register Map Window

Si47xx-EVB

6.10. FM Receiver Logging Tools

The GUI provides several useful logging tools. In the tools menu, user can choose to log raw RDS data, band scan data, device commands and channel info.

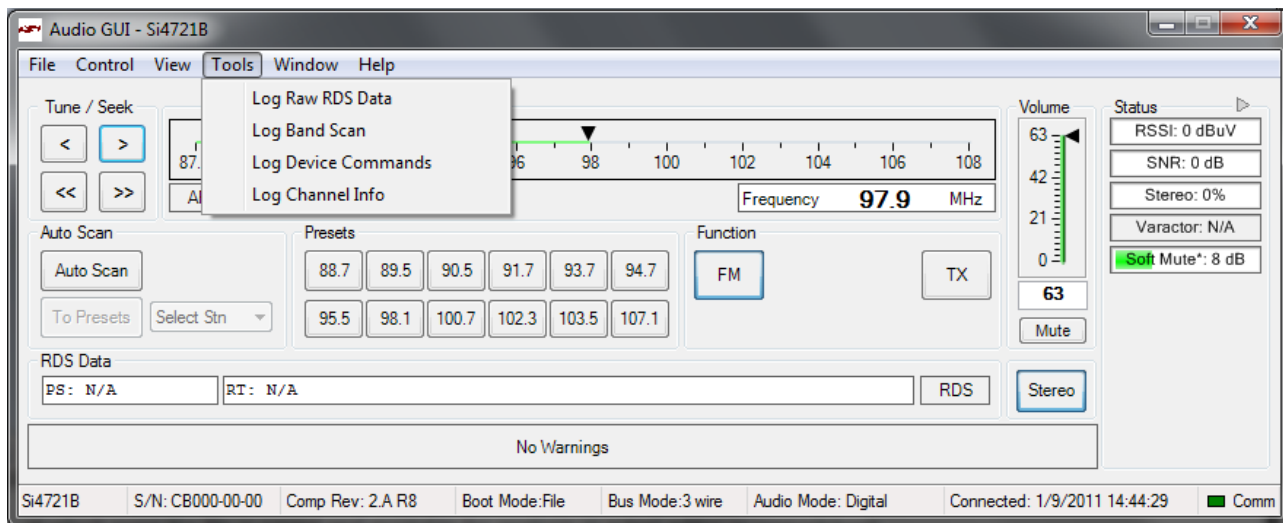

Figure 63. Logging Tools

6.10.1. Log Band Scan

Selecting Tools→Log Band Scan allows you to specify a filename and begin a scan of the entire band for RDS data, RDS acquisition times, and the contents of each register. The scan feature starts with the first frequency in the band (CHAN = 0) and then seeks to the first station that meets the seek criteria (SEEKTH, SKCNT, SKSNR).

When a valid station is found, the software waits at the station for the time specified by View→Session Preferences→Scan Log After Tune Delay (sec) and then checks if RDS is available. If RDS is not available, the software logs the register settings and seeks to the next valid station. If RDS is available, the software waits an additional delay as specified by View→Session Preferences→Scan Log RDS Log Delay (sec). When this delay expires, the software logs the RDS information and register settings and seeks to the next valid station. While scanning, the software displays a green "Scanning" notice below the menu bar. The scan can be aborted by selecting the Tools→Log Band Scan a second time. When the scan completes, the filename given is saved in comma separated format and is available for analysis in a text editor or spreadsheet.

6.10.2. Log Raw RDS Data

Selecting Tools→Log Raw RDS Data prompts for a filename in which all RDS data will be logged in comma separated format. The software then logs all raw RDS data that is received, the station it is received on, and the time at which it was received. The logging will continue until Tools→Log Raw RDS Data is selected a second time at which point the file is saved and available for analysis in a text editor or spreadsheet.

6.10.3. Log Channel Info

Selecting Tools→Log Channel Info prompts for a filename in which all register values will be logged in comma separated format. The software then logs all register values and the time at which it was received. The logging will continue until Tools→Log Channel Info is selected a second time, at which point the file is saved and available for analysis in a text editor or spreadsheet.

6.10.4. Log Device Commands

Selecting Tools→Log Device Commands prompts for a filename in which all software API calls and data with timestamp data will be logged as text. The logging will continue until Tools→Log Device Commands is selected a second time, at which point the file is saved and available for analysis in a text editor.

6.11. FM Receiver Configuration Helper

The configuration helper is a useful tool for configuring the thresholds related to RSSI based Blend, SNR based Blend, Multipath based blend, SNR based hi-cut, Multipath based hi-cut, and Soft Mute.

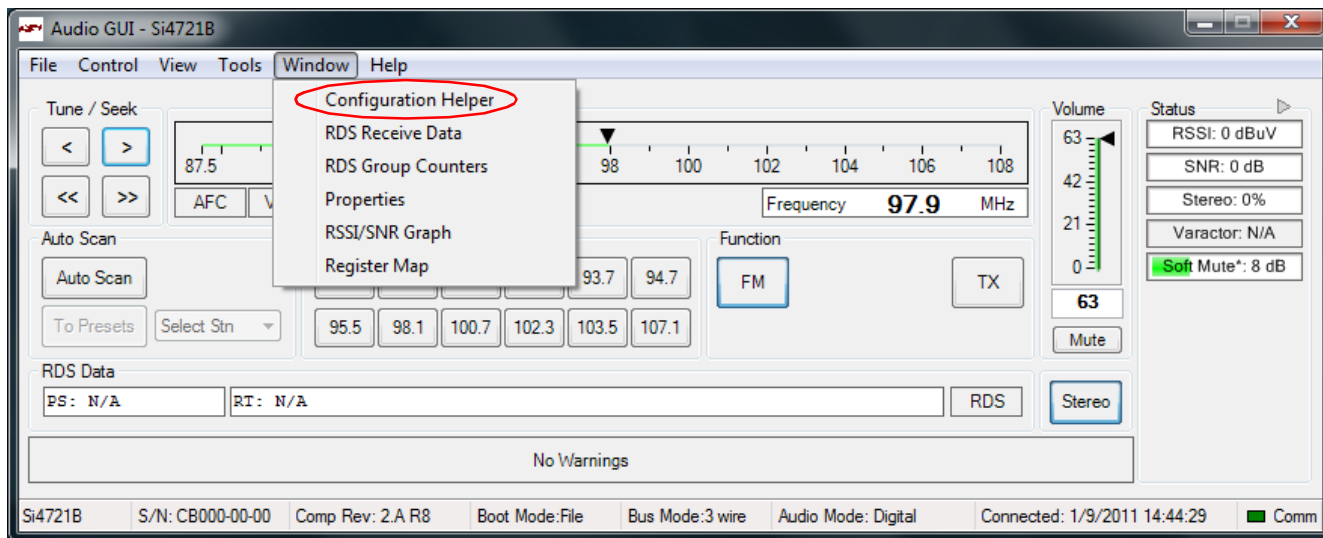

Figure 64. FM Configuration Helper

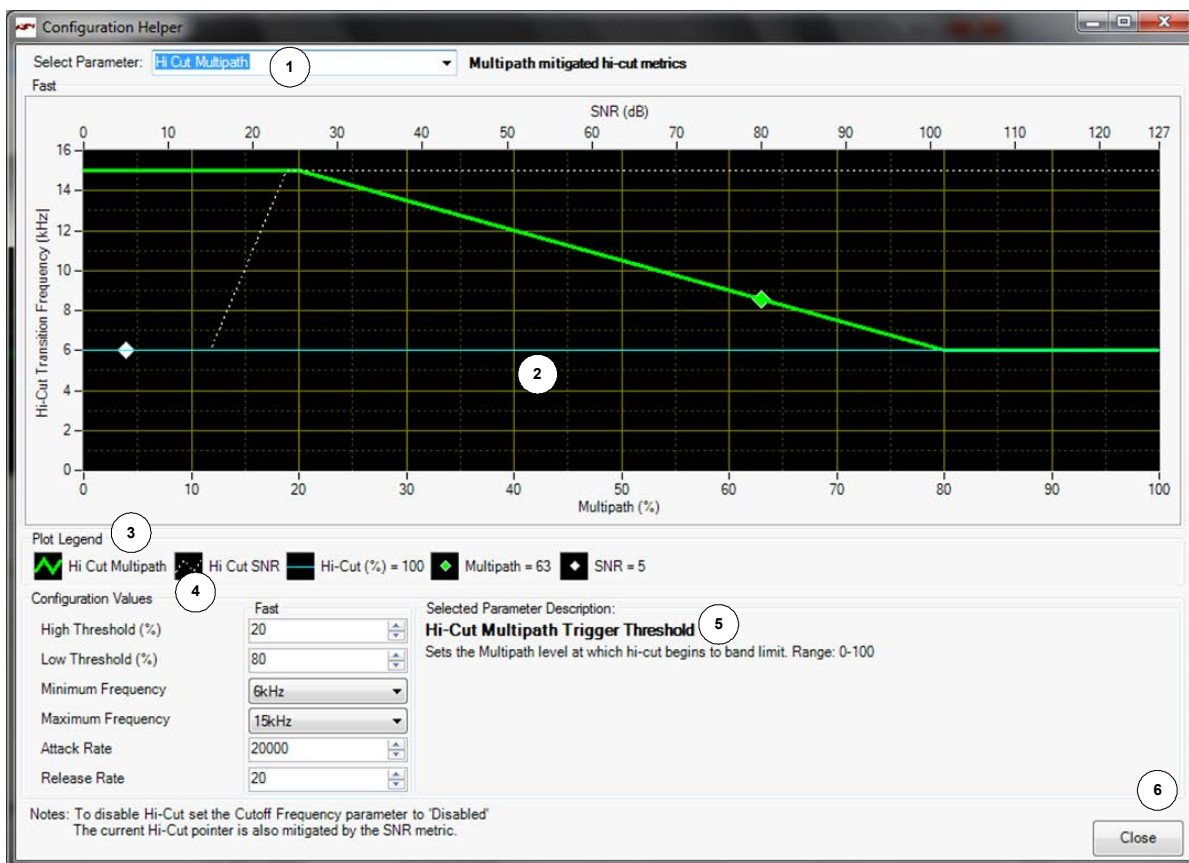

Figure 65. FM Configuration Helper Window (Multipath Based Hi-cut)

Table 21. Configuration Helper Window Descriptions

#	Item	Description
1	Select Parameter	Selects between Hi-cut Multipath (Si4706/4x only), Hi-cut SNR(Si4706/4x only), SoftMute, Stereo blend Multipath (Si4706/4x only), Stereo Blend RSSI and Stereo Blend SNR (Si4706/4x only).
2	Hi-cut/ Blend/Soft Mute Graph	The plot displays the device threshold and rate settings, current signal conditions, and the calculated audio conditioning.
3	Plot Legend	The plot legend includes numeric values for current signal conditions and calculated audio conditioning.
4	Configuration Values	Configure threshold and rate properties. These values are at all times synchronized with the values available through the Properties window.
5	Selected Parameter Description	Read a detailed description of the currently selected parameter in the Configuration Values group.
6	Close	Click this button to close the Configuration Helper window.

In the example shown in Figure 65, the current level marker shows that Hi-cut filter is set at 6 kHz. This is determined by both SNR and multipath conditions. Current SNR is 5 dB. Hi-cut SNR Low Threshold is set at 15 dB and hi-cut minimum frequency is set at 6 kHz. SNR is the determining factor in this case as it is already lower than the low threshold. Graph shows the current state of SNR (white diamond) and multipath (green diamond) and plots for each of them that show the transition between high and low thresholds and how the hi-cut filter frequency would be adjusted accordingly. You can adjust the configuration values to see how these plots and the current state of hi-cut would change.

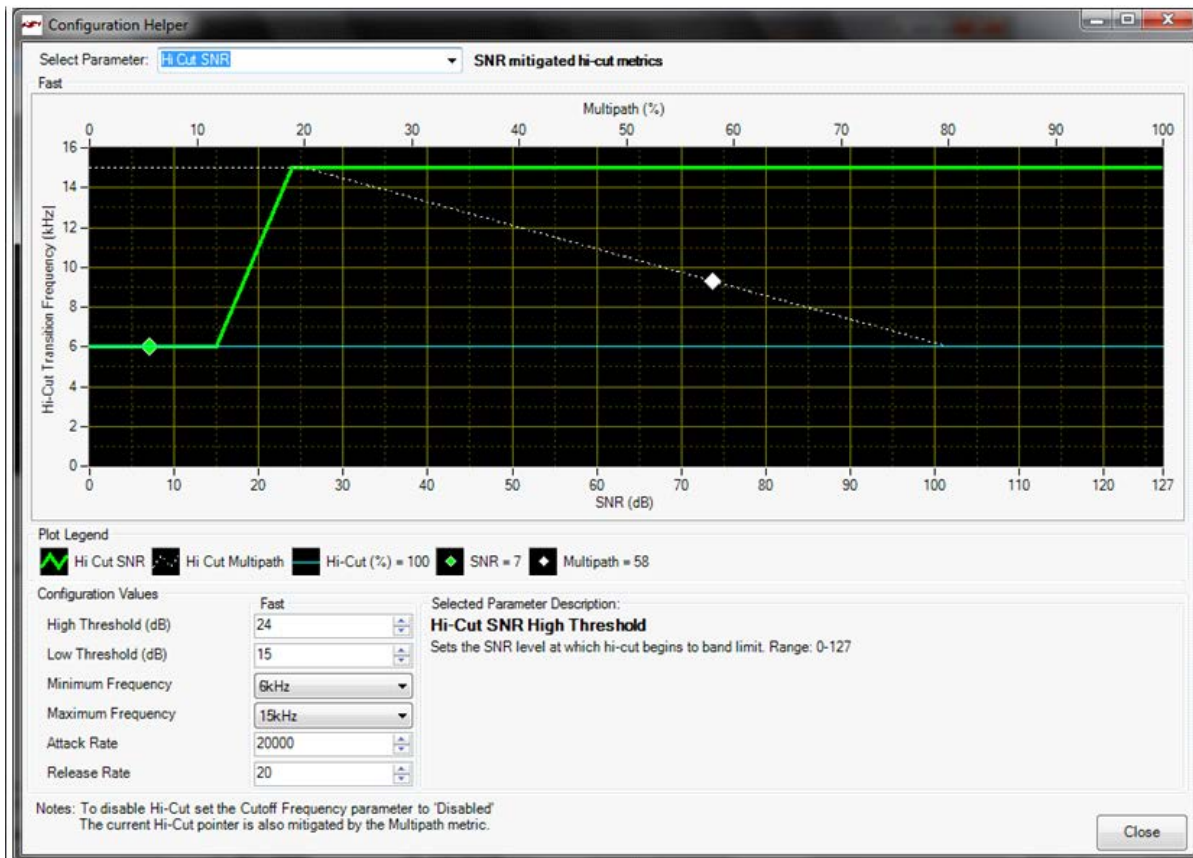

Figure 66. FM Configuration Helper Window (SNR Based Hi-cut)

In the example shown in Figure 66, the current level marker shows that hi-cut filter is set at 6 kHz. This is determined by both SNR and multipath conditions. Current SNR is 5 dB. Hi-cut SNR Low Threshold is set at 15 dB and hi-cut minimum frequency is set at 6 kHz. SNR is the determining factor in this case as it is already lower than the low threshold. The graph shows the current state of SNR (green diamond) and multipath (white diamond) and plots for each of them that show the transition between high and low thresholds and how the hi-cut filter frequency would be adjusted accordingly. You can adjust the configuration values to see how these plots and the current state of hi-cut would change.

Si47xx-EVB

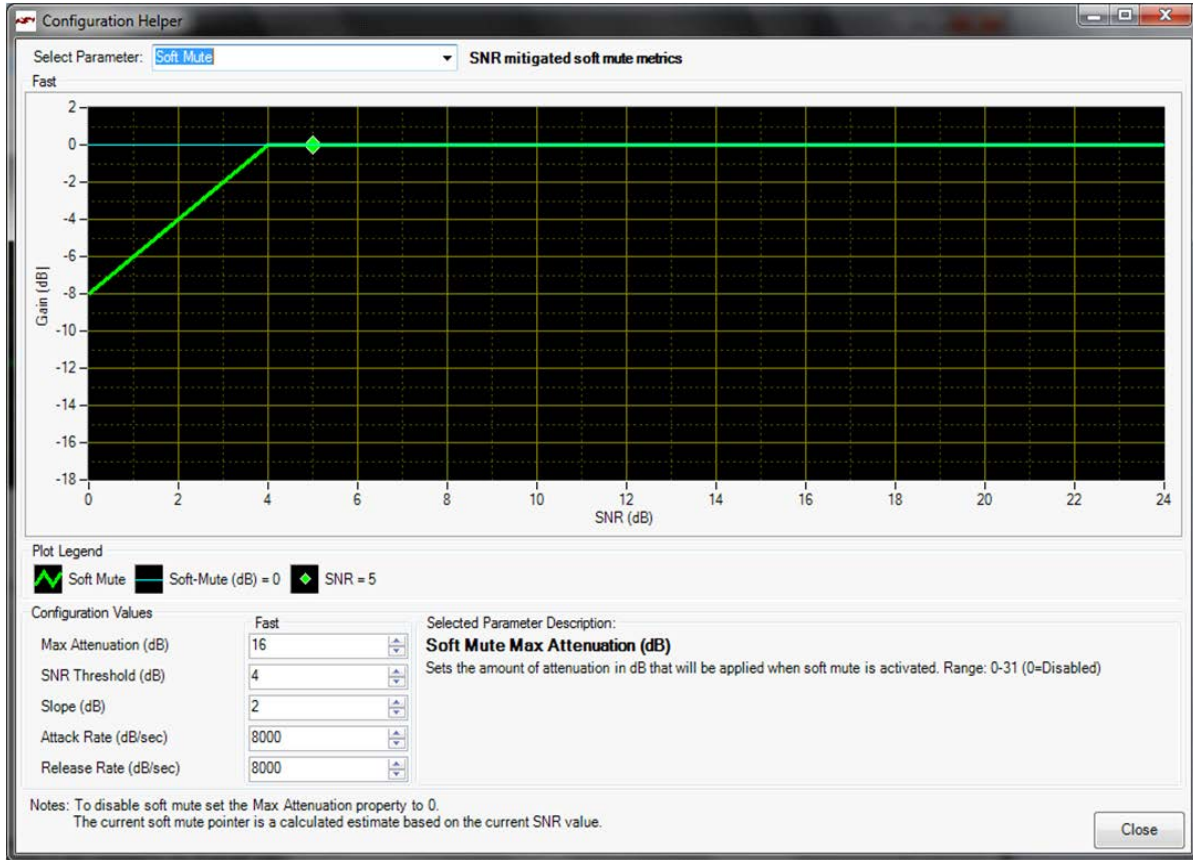

Figure 67. FM Configuration Helper Window (Softmute)

In the example shown in Figure 67, the current level marker shows that Soft Mute level is 0 dB. SNR threshold is programmed as 4 dB and max attenuation is 16 dB. Since the SNR reported by the part is 5 dB, which is above the threshold, the softmute level is 0 dB. The graph shows the current state of SNR (green diamond) and plot shows the softmute profile based on max attenuation, threshold and slope settings. You can adjust the configuration values to see how the plot and the current state of softmute would change.

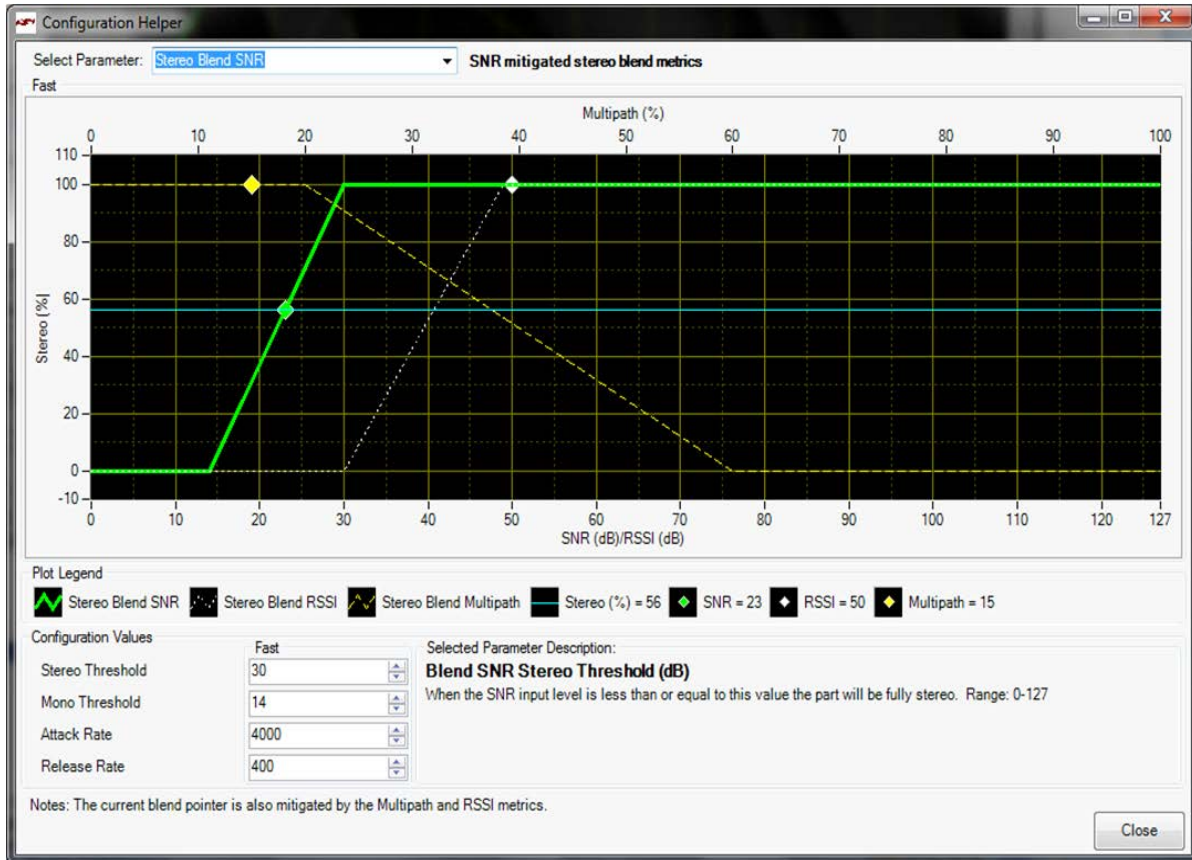

Figure 68. FM Configuration Helper Window (SNR Based Blend)

In the example shown in Figure 68, the Current Level marker shows that Stereo % is 56%. SNR threshold is programmed as 14 dB (and below) for full mono and 30 dB (and above) for full stereo. Since the SNR reported by the part is in between the thresholds, the stereo level is 56%. RSSI and Multipath do not factor in here as they are both at levels that would set the part in full stereo. The graph shows the current state of SNR (green diamond), RSSI (white diamond), and multipath (yellow diamond) and plots for each of them that show the transition between high and low thresholds and how the blend would be adjusted accordingly. You can adjust the configuration values to see how these plots and the current state of blend would change.

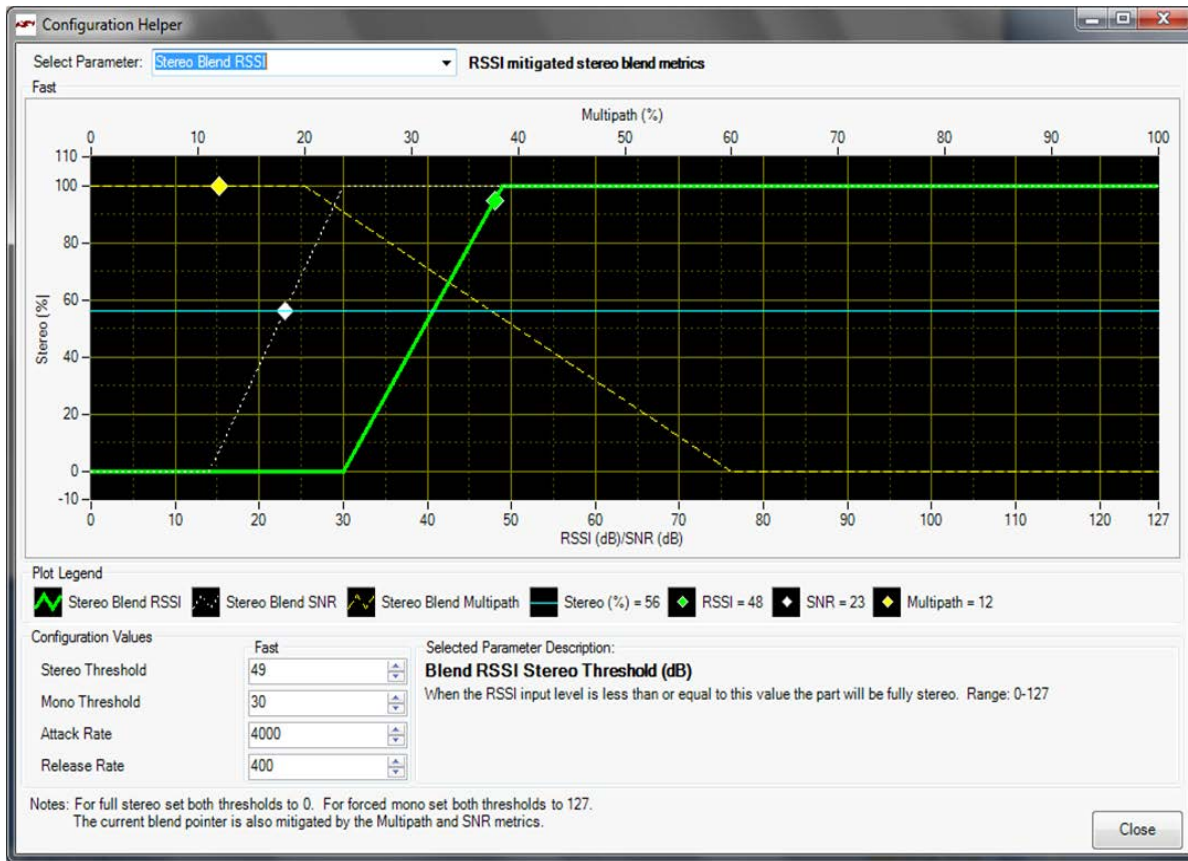

Figure 69. FM Configuration Helper Window (RSSI Based Blend)

In the example shown in Figure 69, the Current Level marker shows that Stereo % is 56%. RSSI threshold is programmed as 30 dB μ V (and below) for full mono and 49 dB μ V (and above) for full stereo. RSSI reported by the part is in between the thresholds however the final blend percentage is determined by SNR and the stereo level is 56%. Multipath does not factor in here as it is at a level that would set the part in full stereo. The graph shows the current state of RSSI (green diamond), SNR (white diamond), and multipath (yellow diamond) and plots for each of them that show the transition between high and low thresholds and how the blend would be adjusted accordingly. You can adjust the configuration values to see how these plots and the current state of blend would change.

In the example shown in Figure 70, the Current Level marker shows that Stereo % is 50%. Multipath threshold is programmed as: 60% (and above) for full mono and 20% (and below) for full stereo. Multipath reported by the part is 11% which would put the part in full stereo. However the final blend percentage is determined by SNR and the stereo level is 56%. The graph shows the current state of Multipath (green diamond), RSSI (white diamond) and SNR (yellow diamond) and plots for each of them that show the transition between high and low thresholds and how the blend would be adjusted accordingly. You can adjust the configuration values to see how these plots and the current state of blend would change.

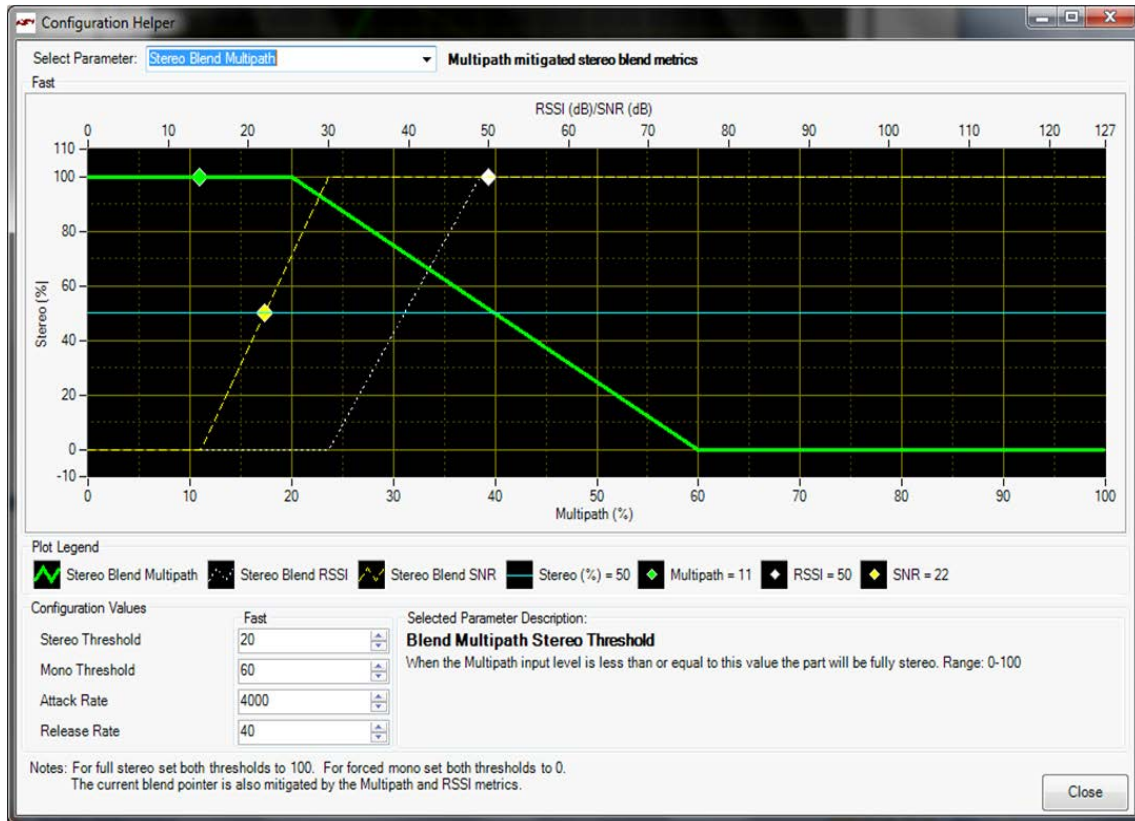

Figure 70. FM Configuration Helper Window (Multi-path Based Hi-blend)

7. Weather Band GUI

7.1. WB Receiver Initialization

The first Si47xx window is the Initialization window as shown in Figure 71. On the function menu, select and highlight the function of the Si47xx as a WB Receiver. Select the Boot Mode, Audio Mode, Firmware, Bus Mode, and initial part settings and then click Initialize. A new window displaying "Initializing WB Receiver" will appear. If you check "Use XOSCEN," the daughter card crystal and on-chip oscillator will be used to clock the Si47xx. You can also select "(Analog Mode) to Analog Output", "(Digital Mode) to SPDIF and CODEC (Analog Output)", or "(Analog & Digital Mode) to Analog Output and SPDIF" with the Audio Mode drop down menu.

Note: SPDIF will not be supported on new EVBs as of February 14, 2011. Modes of operation requiring the SPDIF will not be available in the initialization window for those boards.

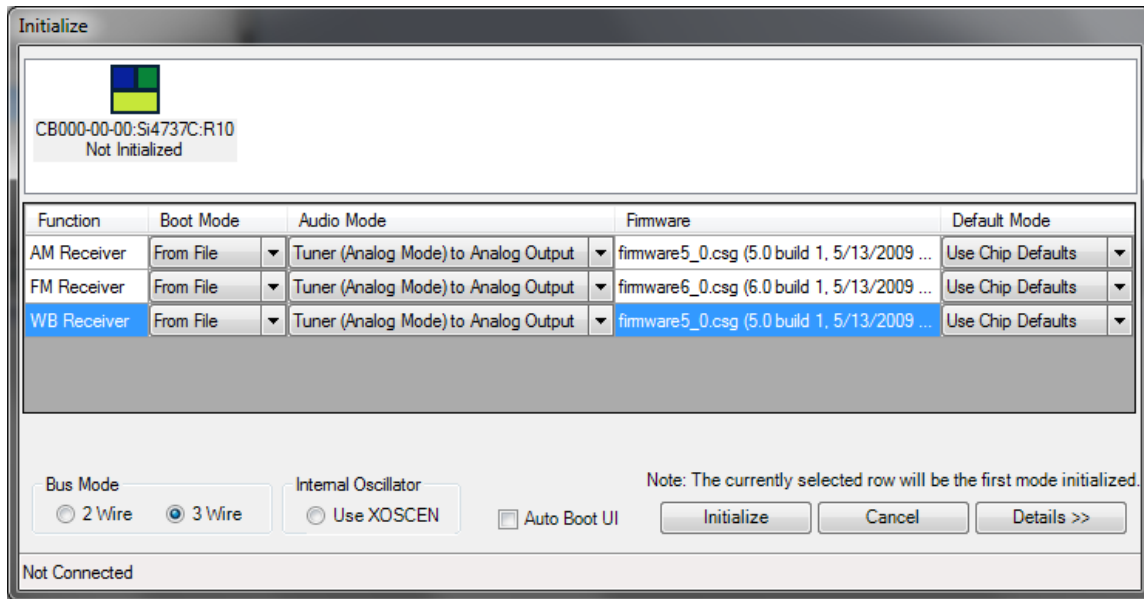

Figure 71. Weather Band Receiver Initialization

7.2. Weather Band Main Window

The weather band main window will appear after initialization.

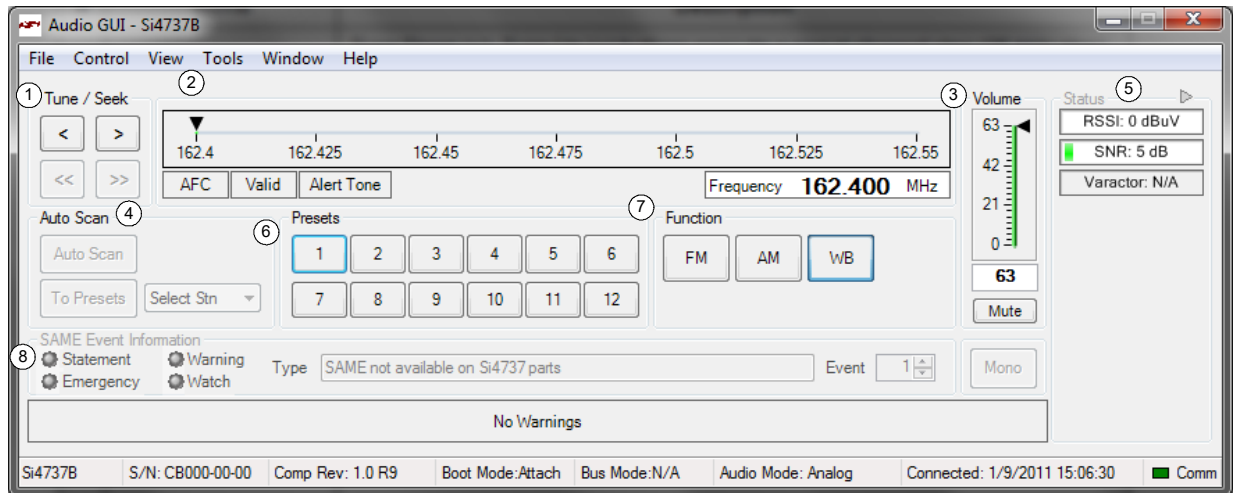

Figure 72. Weather Band Receiver Main Window

Table 22. Weather Band Receiver Main Window Descriptions

#	Name	Description
1	Tune/Seek	Tune Down (<), Tune Up (>) buttons execute a signal channel step (25 kHz step). Seek function is not available in the WB Receiver mode.
2	Frequency Slider Bar, AFC Valid, Alert Tone	The Frequency Display indicates the frequency in MHz. To change the frequency, drag the pointer in the Frequency Slider Bar to the desired frequency. AFC Rail indicator will be red if the tuned frequency is in an AFC rail state; otherwise the indicator will be grey. The Alert Tone indicator will be green if the 1050 Hz Alert Tone is detected.
3	Volume, Mute	Select the Si473x output volume (0-63) by moving the slider bar pointer. Press the Mute button on the mute radio. The button will be red if the radio is muted. Press the Mute button again to remove the muting.
4	Auto Scan, To Preset, Select Stn	Auto Scan, To Preset, Select Stn functions are not available in the WB Receiver mode.
5	Status	The RSSI indicator displays the RSSI of the signal in dBuV. The SNR indicator displays the SNR of the received signal in dB. The varactor is not available in the WB Receiver mode.
6	Preset	Press the desired button to tune to the frequency displayed on the button. To store a new value to the preset button, tune to the desired frequency and then press and hold the desired button for 1.5 seconds. The button will then change to indicate the stored frequency. This information is stored to a file and used the next time the program is run.
7	Function	The Function buttons are used to boot up the device in a different mode.
8	SAME Event Information	The SAME Event Information displays the SAME Event Information. Use the up/down arrow key to view different events. (Si4707 only)

7.3. Weather Band Settings Property Window

WB receiver settings can be configured through the properties window by selecting Window→Properties. Properties are grouped into categories which can be selected from the drop-down box in the upper right of the window. For convenience, all WB receiver properties are also located in Window→Properties→WB: All.

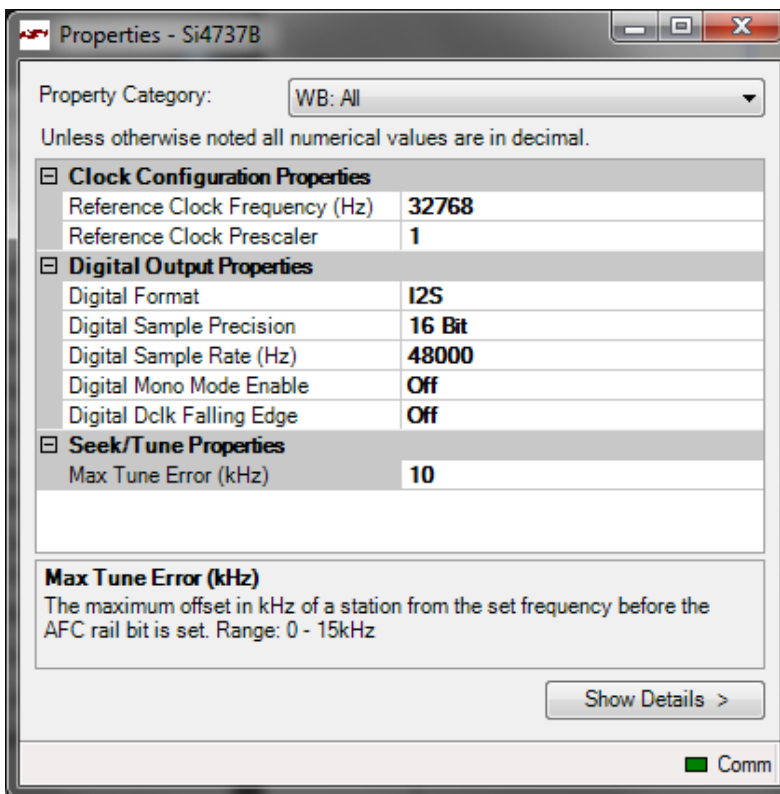

Figure 73. Weather Band Receiver Settings Property Window

Table 23. Weather Band Receiver Settings Property Window

Item	Description	Range	Applicable Devices
Clock Configuration Properties			All
Reference Clock Frequency (Hz)	This field is used to specify the frequency of the reference clock. The input to the RCLK pin divided by the prescaler is the reference clock. The reference clock must be in the range of 31130 to 34406 Hz.	31130–34406 Hz	All
Reference Clock Prescaler	This field is used to specify the prescaler value. The input to the RCLK pin divided by the prescaler is the reference clock. The reference clock must be in the range of 31130 to 34406 Hz.	1–4095 Hz	All
Digital Output Properties			All
Digital Format	Format of digital audio output.	I ² S, Left-Justified, DSP	All
Digital Sample Precision	Digital audio output bit precision.	8-bit, 16-bit, 20-bit, 24-bit	Si4743/47/49

Table 23. Weather Band Receiver Settings Property Window (Continued)

Item	Description	Range	Applicable Devices
Digital Sample Rate Hz	DFS sample rate for digital input signal. Recommended values are: 32 kHz, 44.1 kHz, or 48 kHz. Over-sampling rate must be set in order to satisfy a minimum DCLK of 1MHz. Sample rate must be set to 0 before DCLK/DFS is removed.	0, 32000–48000 Hz	All
Digital Mono Mode Enable	ON enables mono in digital audio output.	ON, OFF	All
Digital DCLK Falling Edge	ON uses falling edge of DCLK for sampling.	ON, OFF	All
Seek/Tune Properties			All
Max Time Error (kHz)	If a station is offset from the set frequency by this amount or more, the AFC rail bit is set.	1–15 kHz	All

Si47xx-EVB

7.4. Weather Band Receiver RSSI/SNR Graph Window

The RSSI/SNR Graph Window allows the user to plot RSSI and SNR across the weather band. Bitmap data can be saved to file by selecting File→Save as Bitmap and tabulated data can be saved to file by selecting File→Save to .CSV.

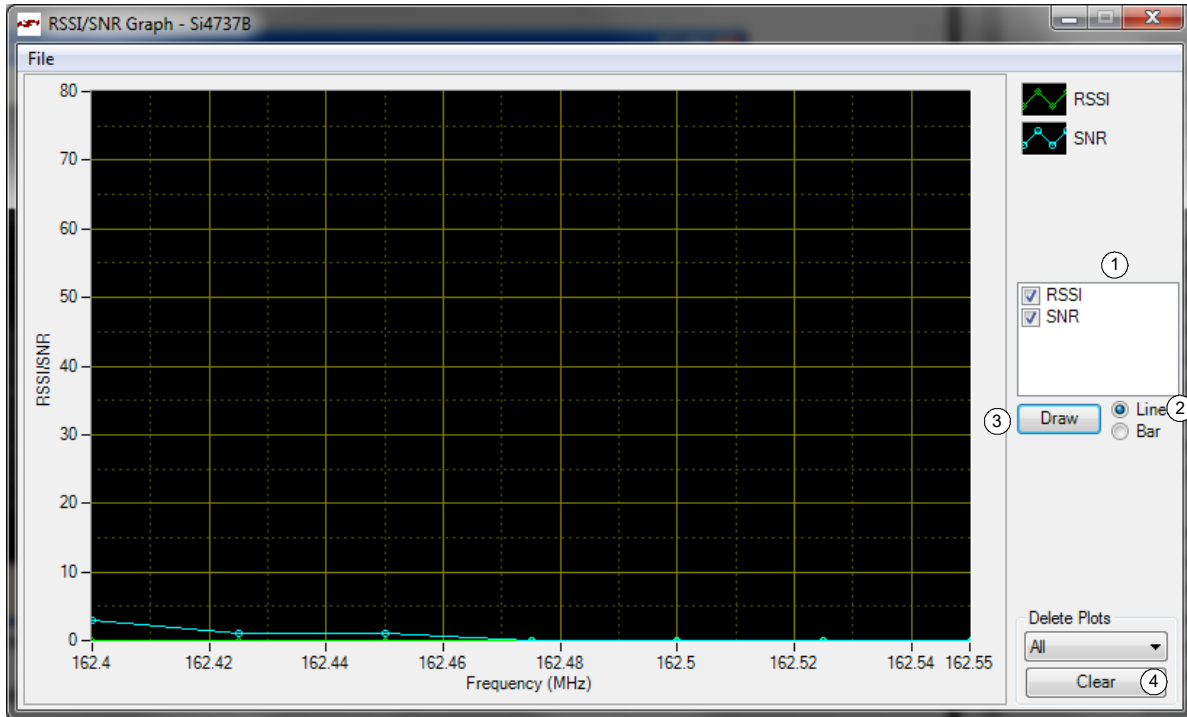

Figure 74. Weather Band Receiver RSSI/SNR Graph Window

Table 24. Weather Band Receiver RSSI/SNR Graph Window Descriptions

#	Items	Description
1	RSSI/SNR Graph	Select between drawing the RSSI, SNR graph, or both.
2	Line/Bar	Select between drawing in bar mode or in continuous line mode.
3	Draw	Click this to start plotting the graph.
4	Clear	Click this button to clear the entire graph.

7.5. Weather Band Receiver Register Map Window

The register map window allows the user to manually program the device by sending commands to the device. Refer to "AN332: Si47xx Programming Guide" to manually program the device.

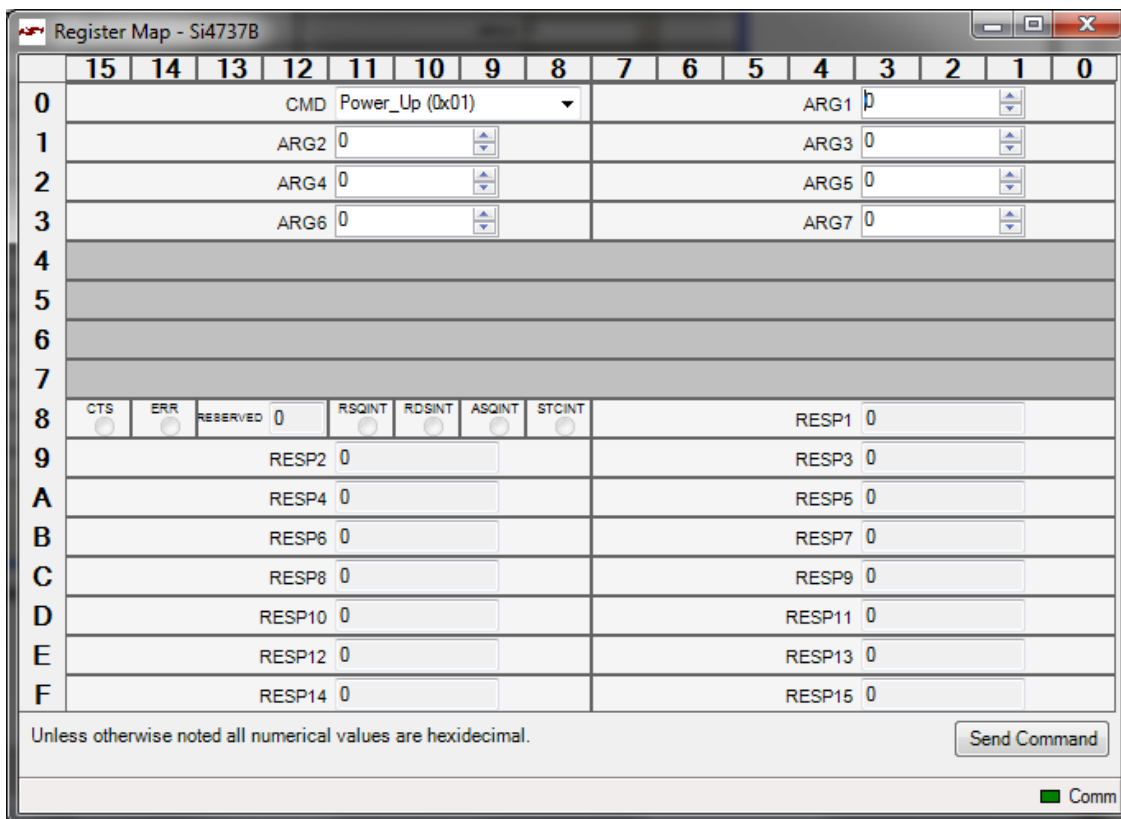

Figure 75. Weather Band Receiver Register Map Window

8. AM Receiver GUI

8.1. AM Receiver Initialization

The first Si474x window is the Initialization window as shown in Figure 77. On the function drop-down menu, select the function of the Si474x as an AM Receiver. Select the device, busmode, firmware revision, and initial part settings and then click Initialize. A new window displaying "Initializing AM Receiver" will appear. Crystal operation is not supported on Si474x-EVB (that supports Si4740/41/42/43/44/45). You can also select Analog Output or Digital Output through SPDIF and CODEC with the EVB Audio Settings drop down box. The AM receiver mode is used for LW reception as well.

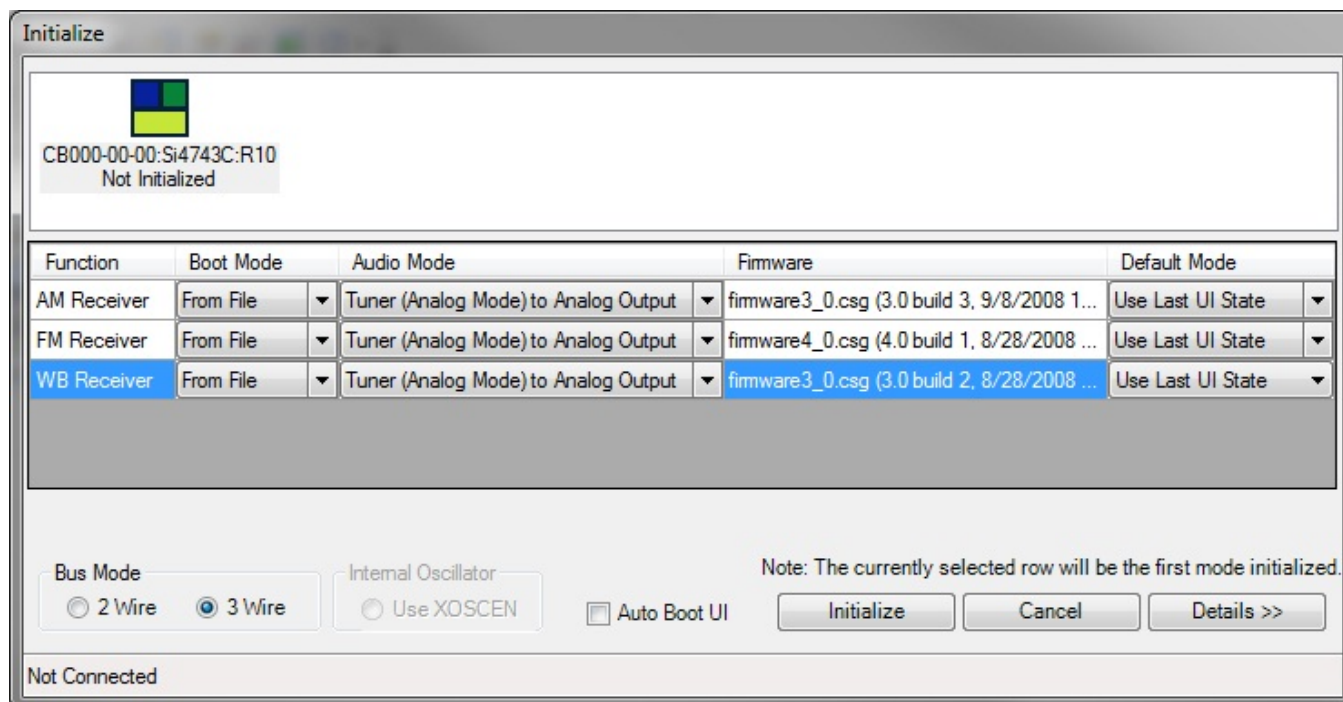

Figure 77. AM Receiver Initialization

Si47xx-EVB

8.2. AM Receiver Main Window

The AM receiver main window will appear after initialization.

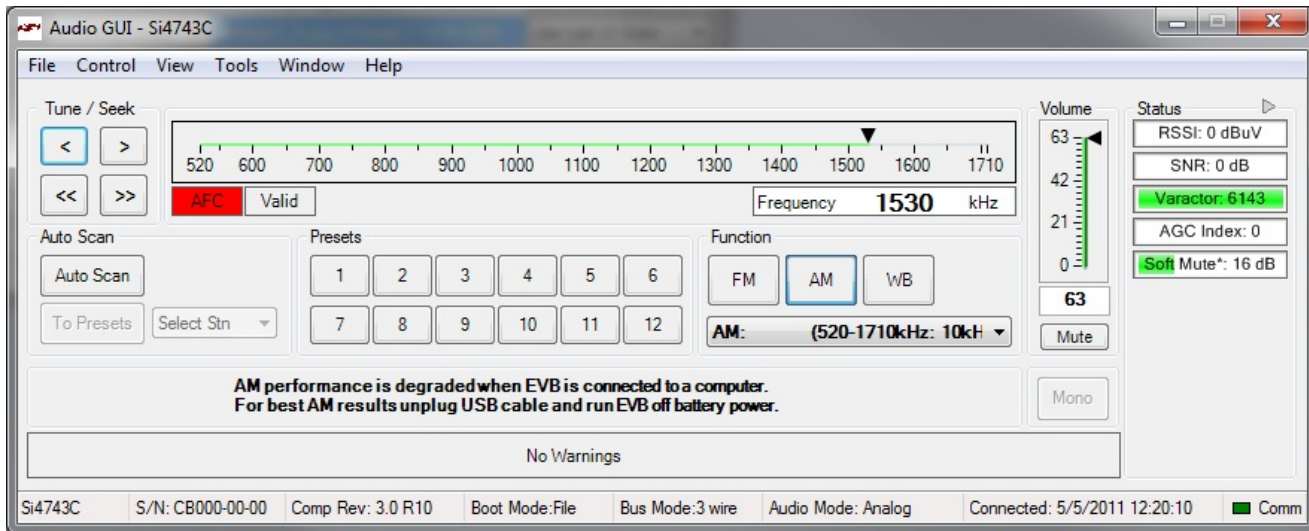

Figure 78. AM Receiver Window

Table 25. AM Receiver Window Descriptions

#	Name	Description
1	Tune/Seek	Tune Down (<), Tune Up (>) buttons execute a single channel step according to the channel spacing setting. The channel spacing setting can be set in the property window. Seek down (<<), Seek Up (>>) buttons execute a seek up or down to the next received FM signal meeting or exceeding the seek settings within the selected band. The seek setting RSSI and SNR threshold can be set in the property window.
2	Frequency Slider Bar, AFC, Valid	The Frequency Display indicates the frequency in kHz. To change the Frequency, drag the pointer in the Frequency Slider Bar to the desired frequency. AFC Rail indicator will be red if the tuned frequency is in an AFC rail state, otherwise the indicator will be grey. The Valid indicator will be green if the AM frequency meets the RSSI and SNR seek settings.
3	Volume, Mute	Select the Si473x output volume (0–63) by moving the slider bar pointer. Press the Mute button to mute the radio. If the radio is muted the button will be red. Press the Mute button again to remove the muting.
4	Auto Scan	The Auto Scan button will find all the stations with an RSSI and SNR above the seek settings in the property window. After the scan is completed, the number of stations found will be displayed and each station will be available in the drop down box. Also, a red indicator mark will be displayed on the Frequency Slider Bar (2) for each station. The "To Presets" Button will program the preset buttons (5) with the 12 strongest stations.
5	Presets	Press the desired button to tune to the frequency displayed on the button. To store a new value to the preset button, tune to the desired frequency and then press and hold the desired button for 1.5 seconds. The button will then change to indicate the stored frequency. This information is stored to a file and used the next time the program is run.

Table 25. AM Receiver Window Descriptions (Continued)

#	Name	Description
6	Status	The RSSI indicator displays the RSSI of the signal in dBuV. The SNR indicator displays the SNR of the received signal in dB. The varactor value specifies the capacitance of the tuning front-end. A value of 6143 means that the maximum capacitance is being presented at the AM input and a value of 1 means that the varactor is at its minimum value. The AGC Index indicator displays the AGC status. The Soft Mute indicator displays the estimated attenuation applied to the signal based on RSSI and SNR values.
7	Function, Band Selection	The Function buttons are used to boot up the device in different mode. Using the Band Selection drop down box, you can select different AM, LW, or SW bands. The drop down box will only appear with LW or SW enabled device. If an SW band is selected using the SW/WB Antenna Card, set the varactor to 1 for best performance. LW not support with SW/WB Antenna Card.

Si47xx-EVB

8.3. AM Receiver Property Settings Window

AM receiver settings can be configured through the properties window by selecting Window→Properties. Properties are grouped into categories which can be selected from the drop-down box in the upper right of the window. For convenience, all AM receiver properties are also located in Window→Properties→AM: All.

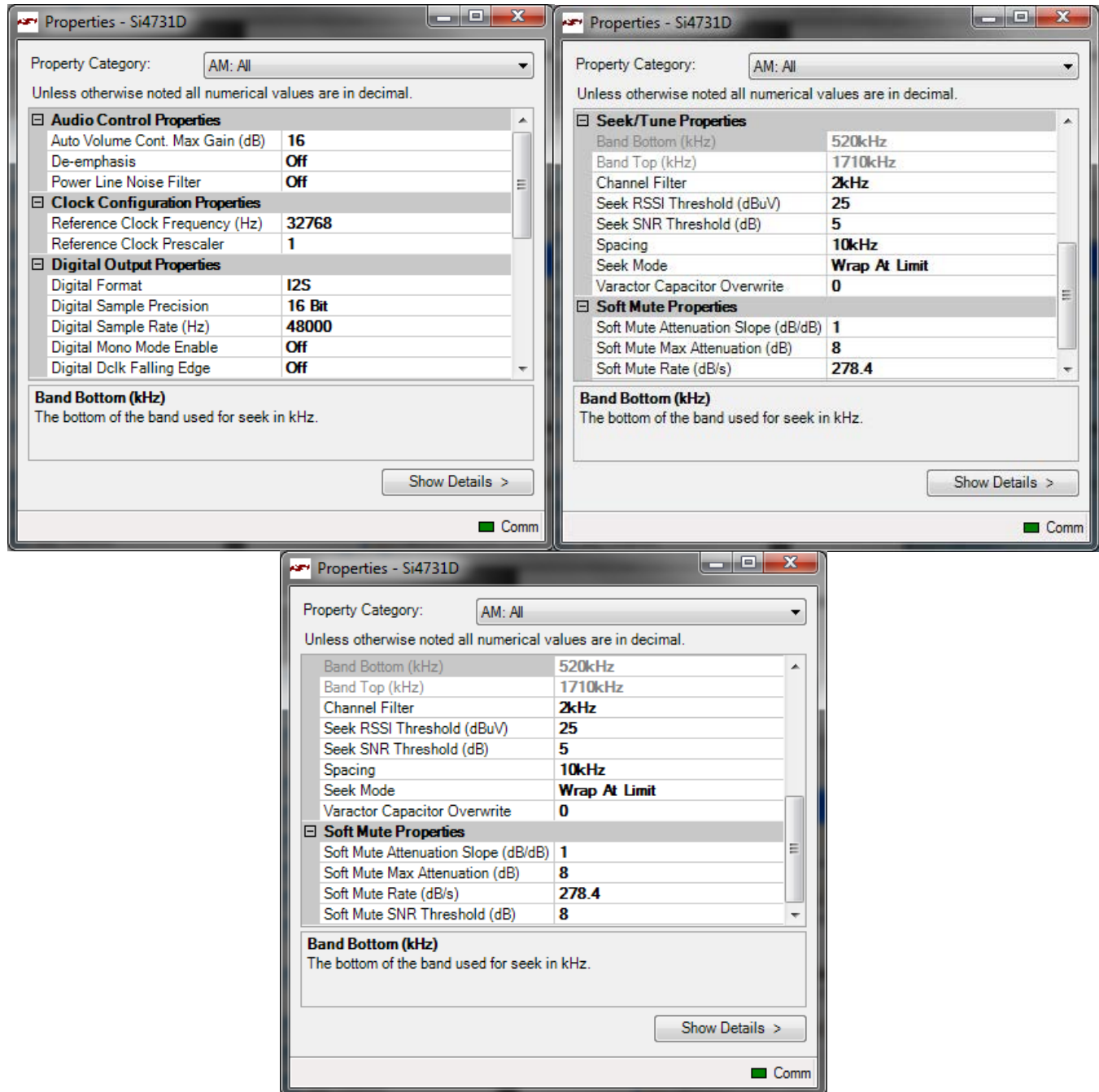

Figure 79. AM Receiver Settings Property Window

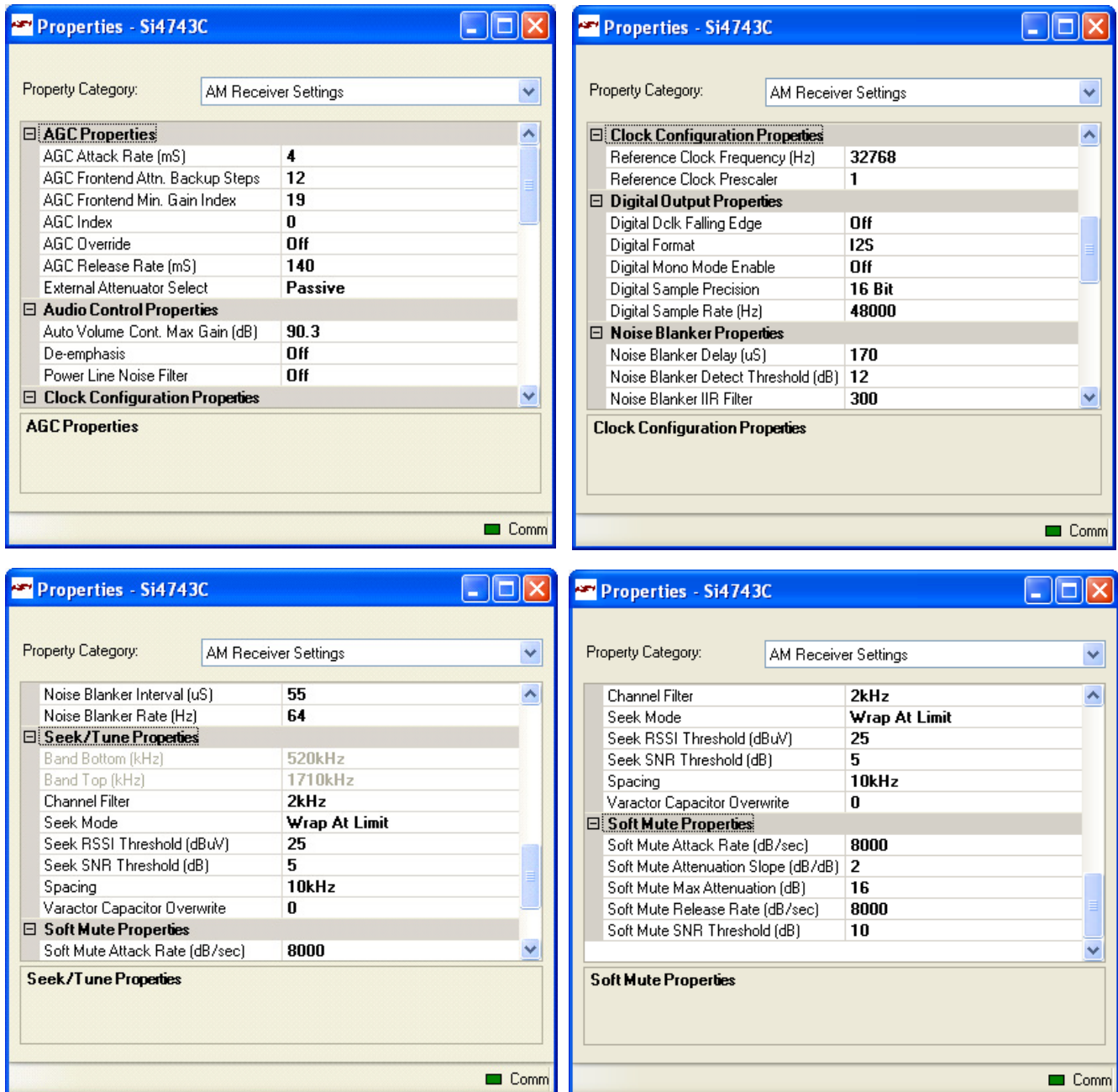

Figure 80. AM Receiver Settings Property Window for Si474x

Si47xx-EVB

Table 26. AM Receiver Property Window Descriptions

Name	Description	Range	Applicable Devices
AGC Attack Rate	Sets the AGC attack rate. Larger values provide slower attack and smaller values provide faster attack.	4–248	Si4740/41/42/43/44/45
AGC Frontend Attn. Backup Steps	Sets gain index backup (ATTN_BACKUP) for external attenuator. For Si4743EVB, 12 and 20 are recommended for "Passive" and "Active" external attenuators, respectively.	0–28 (AM Component 2.E.5)	Si4740/41/42/43/44/45
AGC Frontend Min. Gain Index	Sets minimum gain index. For Si4743EVB, 19 is recommended.	0–28 (AM Component 2.E.5)	Si4740/41/42/43/44/45
AGC Index	Sets gain index when "AGC Override" is On.	0– 37+ATTN_BACKUP	All
AGC Override	When "Off", AGC is enabled. When "On", AGC is disabled and gain index is forced to "AGC Index"	ON/OFF	All
AGC Release Rate	Sets the AGC release rate. Larger values provide slower release and smaller values provide faster release.	4–248	Si4740/41/42/43/44/45
External Attenuator Select	For Si474x-EVB daughtercard versions ≥ 1.2 . When using an antenna, set this property to PASSIVE. If you are connecting a signal generator directly, set this to ACTIVE.	ACTIVE, PASSIVE	Si4740/41/42/43/44/45
Auto Volume Cont. Max Gain (dB)	Sets the maximum gain allowed for automatic volume control.	6.02–90.3 dB	Si473x-C40 and later, Si474x
De-Emphasis	De-emphasis filter setting allows the user to select whether to turn on/off the de-emphasis filter.	ON/OFF	All
Power Line Noise Filter	ON enables high pass filter to filter out the 50/60 Hz tone.	ON/OFF	Si473x-C40 and later, Si4740/41/42/43/44/45
Reference Clock Frequency (Hz)	This field is used to specify the frequency of the reference clock. The Reference clock frequency divided by the pre-scalar must be in the range of 31.130 to 34.406 kHz.	31130–34406 Hz	All
Reference Clock Prescaler	Reference Clock Pre-scalar divides down RCLK frequency by the value specified in this field. The Reference clock frequency divided by the pre-scalar must be in the range of 31.130 to 34.406 kHz.	1–4095	All
Digital DCLK Falling Edge	ON uses falling edge of DCLK for sampling.	ON, OFF	Si4705/06, Si4731/35/37/39, Si4730/34/36/38-D60 and later, Si4741/43/45, Si4784/85

Table 26. AM Receiver Property Window Descriptions (Continued)

Name	Description	Range	Applicable Devices
Digital Format	Format of digital audio output.	I2S, Left-Justified, DSP	Si4705/06, Si4731/35/37/39, Si4730/34/36/38-D60 and later, Si4741/43/45, Si4784/85
Digital Mono Mode Enable	ON enables mono in digital audio output.	ON, OFF	Si4705/06, Si4731/35/37/39, Si4730/34/36/38-D60 and later, Si4741/43/45, Si4784/85
Digital Sample Precision	Digital audio output bit precision.	8-bit, 16-bit, 20-bit, 24-bit	Si4705/06, Si4731/35/37/39, Si4730/34/36/38-D60 and later, Si4741/43/45, Si4784/85
Digital Sample Rate Hz	DFS sample rate for digital input signal. Recommended values are: 32 kHz, 44.1 kHz, or 48 kHz. Over-sampling rate must be set in order to satisfy a minimum DCLK of 1 MHz. Sample rate must be set to 0 before DCLK/DFS is removed.	0, 32000–48000 Hz	Si4705/06, Si4731/35/37/39, Si4730/34/36/38-D60 and later, Si4741/43/45, Si4784/85
Noise Blanker Delay	Delay in microseconds before applying noise blanking to the original samples.	125–205 μ s	Si4742/43/44/45
Noise Blanker Detect Threshold	Sets the threshold for detecting impulses in dB above the noise floor. If set to 0, impulse noise blanking is disabled.	0 – 90 dB	Si4742/43/44/45
Noise Blanker IIR Filter	Sets the cut-off frequency for the low pass filter that is used for noise floor estimation in noise blanker detection.	300–1600	Si4742/43/44/45
Noise Blanker Interval	Interval original samples are replaced by interpolated clean samples.	8 – 48 μ s	Si4742/43/44/45
Noise Blanker Rate	Maximum noise blanking rate.	100 – 6400 Hz	Si4742/43/44/45
Band Bottom Limit (kHz)	The lower frequency limit for the seek function. This is set automatically by the GUI based on spacing selection.	10 kHz Spacing: 520 kHz 9 kHz Spacing: 510 kHz	All
Band Top Limit (kHz)	The upper frequency limit for the seek function.	1710 kHz	All
Channel Filter	Channel Filter allows the user to select the bandwidth of the bandpass channel filter.	1, 1.8, 2, 3, 4, 6 kHz	All

Si47xx-EVB

Table 26. AM Receiver Property Window Descriptions (Continued)

Name	Description	Range	Applicable Devices
Seek Mode	Seek mode specifies the behavior of seek when it reaches either end of the AM band. The default value makes the seek wrap around and start at the other end of the AM band. The other option makes seek stop if it reaches either end of the AM band without finding an AM station.	Stop at Limit or Wrap at Limit	All
Seek RSSI Threshold (dB μ V)	Seek RSSI threshold is a metric that is used when using the seek feature. Any signal with an RSSI lower than the threshold will be ignored during a seek.	0–63 dB μ V	All
Seek SNR Threshold (dB)	Seek SNR threshold is a metric that is used when using the seek feature. Any signal with an SNR lower than the threshold will be ignored during a seek.	0–63 dB	All
Spacing	Allows specification of the step spacing when tuning with the GUI.	9 or 10 kHz	All
Varactor Capacitor Overwrite	Varactor capacitance overwrite allows the specification of the capacitance presented to the AMI pin from the tunable capacitor inside the part. A value of 0 automatically selects the value.	Automatic: 0 Manual: 1–6143	All except Si4710-A10
Soft Mute Attack Rate (dB/s)	Sets the attack rate for entering soft mute.	1–31999 dB/s	Si4740/41/42/43/44/45
Soft Mute Attenuation Slope (dB/dB)	Soft mute attenuation slope specifies the slope of the attenuation curve when the signal SNR is below the soft mute SNR threshold. It is specified as dB/dB where the attenuation applied is simply the value specified here times the amount the signal SNR is below the threshold.	1–5	All
Soft Mute Max Attenuation (dB)	Soft mute attenuation is the amount of attenuation that takes place when the signal falls below the soft mute threshold.	0–63 dB 0 = disable	All
Soft Mute Release Rate (dB/s)	Sets the release rate for leaving soft mute.	1–31999 dB/s	Si4740/41/42/43/44/45
Soft Mute SNR Threshold (dB)	Soft mute SNR threshold is the level below which soft mute is activated.	0–63 dB	All

8.4. AM Receiver RSSI/SNR Graph Window

The RSSI/SNR graph window allows the user to plot RSSI and SNR across the AM band. Bitmap data can be saved to file by selecting File→Save as Bitmap and tabulated data can be saved to file by selecting File→Save to .CSV.

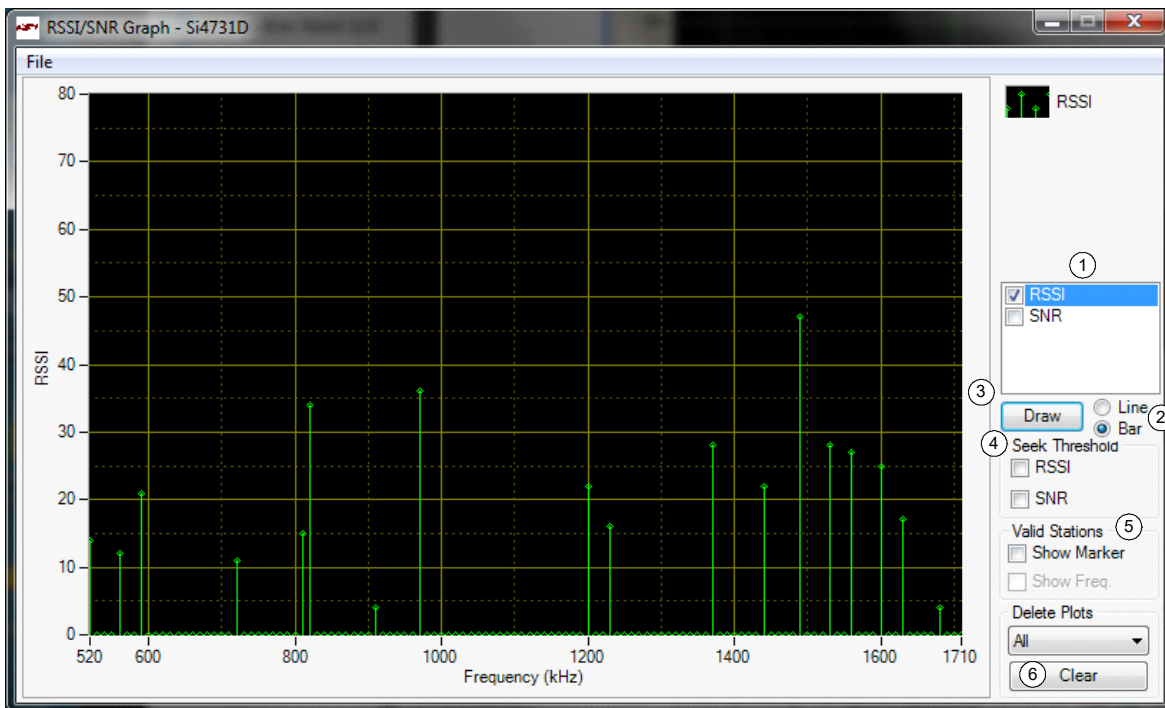

Figure 81. AM Receiver RSSI/SNR Graph Window

Table 27. FM Receive RSSI/SNR Graph Window Descriptions

#	Items	Description
1	RSSI / SNR Graph	Select between drawing the RSSI or SNR graph.
2	Line / Bar	Select between drawing in bar mode (depicted as green) or in continuous line mode (depicted as yellow).
3	Draw	Click this to start plotting the graph
4	Seek Threshold (RSSI / SNR)	Draw the RSSI and/or SNR seek threshold as specified in the respective properties. The RSSI seek threshold is shown in red; the SNR seek threshold is shown in orange.
5	Mark Valid Stations	Mark Valid Stations based on the RSSI/SNR seek threshold settings.
6	Clear	Click this button to clear the traces selected in the Delete Plots combo box.

Si47xx-EVB

8.5. AM Receiver Register Map Window

The register map window allows the user to manually program the device by sending commands to the device. Refer to "AN332: Si47xx Programming Guide" to manually program the device.

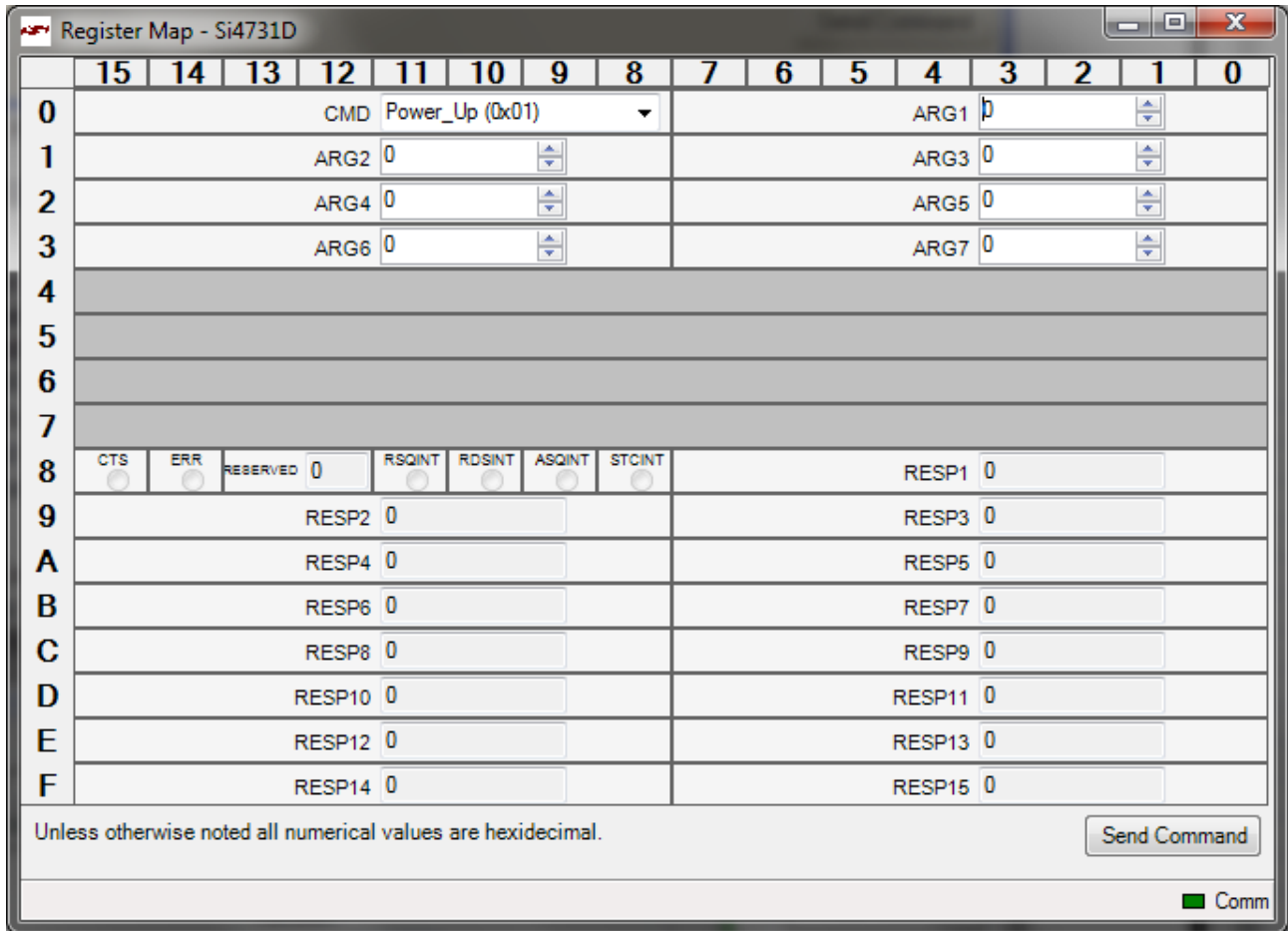

Figure 82. AM Receiver Register Map Window

8.6. AM Receiver Logging Tools Info

8.6.1. Log Band Scan

Selecting Tools→Log Band Scan allows you to specify a filename and begin a scan of the entire band. The scan feature starts with the first frequency in the band and then seeks to the first station that meets the seek criteria (Seek RSSI Threshold, Seek SNR Threshold). When a valid station is found, the software waits at the station and logs Frequency, AFC, RSSI, SNR, Soft Mute etc settings and then seeks to the next valid station. While scanning, the software displays a green "Scanning" notice below the menu bar. The scan can be aborted by selecting the Tools→Log Band Scan a second time. When the scan completes, the filename given is saved in comma separated format and is available for analysis in a text editor or spreadsheet.

8.6.2. Log Device Commands

Selecting Tools→Log Device Commands prompts for a filename in which all software API calls and data with timestamp data will be logged as text. The logging will continue until Tools→Log Device Commands is selected a second time, at which point the file is saved and available for analysis in a text editor.

8.6.3. Log Channel Info

Selecting Tools→Log Channel Info prompts for a filename in which all register values will be logged in comma separated format. The software then logs all register values and the time at which it was received. The logging will continue until Tools→Log Channel Info is selected a second time, at which point the file is saved and available for analysis in a text editor or spreadsheet.

Si47xx-EVB

8.7. AM Receiver Configuration Helper

Selecting Window→Configuration Helper opens up the Configuration Helper window. The Configuration Helper is a very useful tool to configure the thresholds and the rates associated with Soft-Mute.

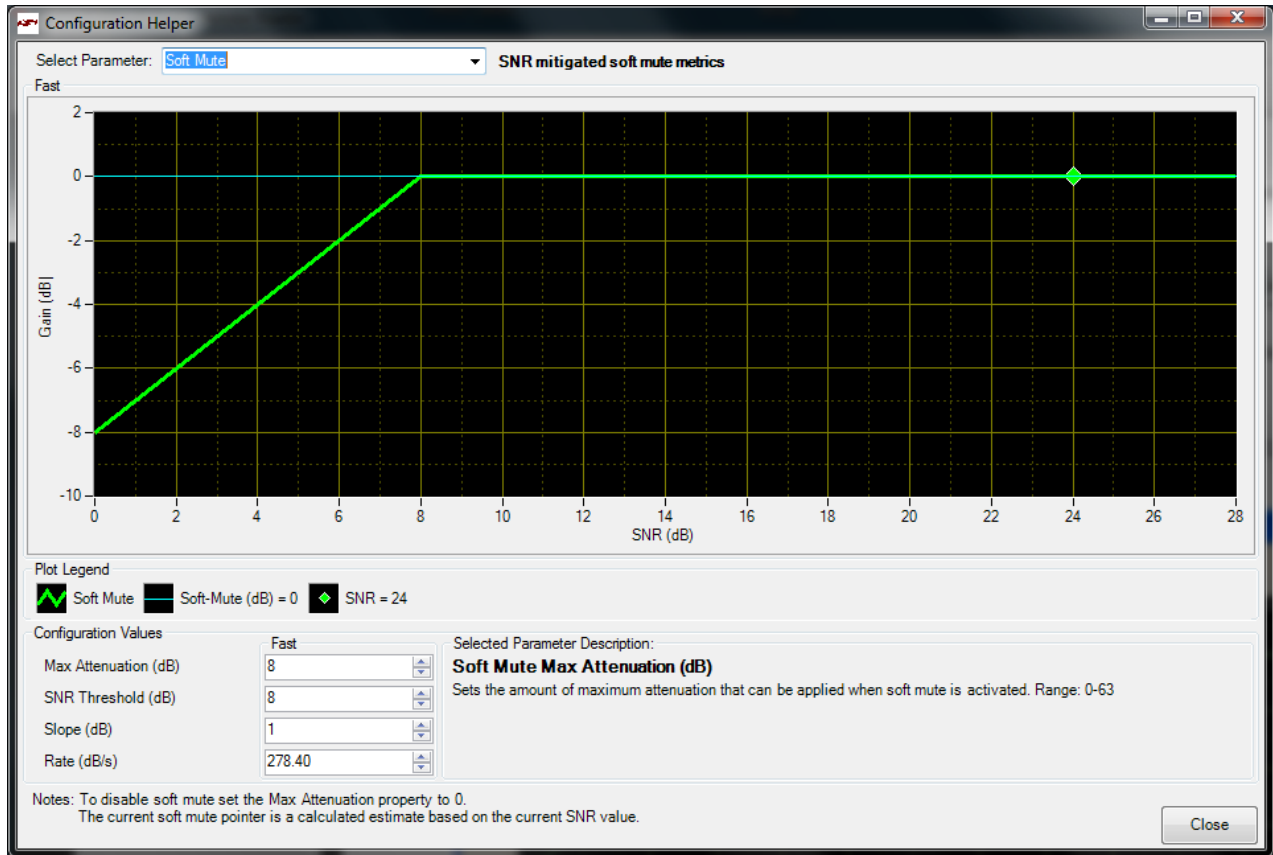

Figure 83. AM Configuration Helper Window

In the example shown in Figure 83, the audio signal does not get attenuated because the SNR reported by the chip is greater than the programmed SNR threshold for Soft Mute.

9. Using the EVB with a 9 V Battery

The EVB can be used with a 9 V battery that allows the user to disconnect the board from the computer for evaluating the Si47xx. Follow the guidelines listed below to use your EVB with a 9 V battery.

1. Put the switch SW1 in the Ext/Battery position.
2. Connect a 9 V battery to jumper J77.
3. Connect the USB cable.
4. Launch the GUI.
5. Initialize the EVB for AM or FM reception.
6. Once the desired station is tuned and all the settings for the receiver are according to the user's liking, please exit the GUI.
7. When asked whether to leave the device on, please click on yes.
8. Remove the USB cable.
9. The EVB can now be moved around.

Note that once the EVB is using its 9 V battery, it is not possible to change the tuned station. Repeat steps 3–9 to tune the EVB to a different station while running on the 9 V battery.

Si47xx-EVB

10. Debugging Guidelines for Si47xx EVB

Table 28. Debugging Guidelines for Si47xx EVB

Mode	Symptom	Solution
Configuration	EVB not recognized	<ul style="list-style-type: none"> ■ If the EVB is not recognized by the PC, remove the USB connection and reconnect. Ensure the EVB is recognized by the PC by right-clicking on My Computer and selecting Properties→Hardware→Device Manager. Under Human Interface Devices, select each HID-Compliant Device→“Details entry and confirm one contains VID_10C4&PID_8244. ■ IF the EVB is not recognized by the GUI, but is recognized by the PC, it is likely that another process has erroneously acquired the handle to the EVB. Two processes known to cause this issue are lxhidsve.exe and EAUSBKBD.exe. Terminate these processes in the Task Manager. ■ If EVB is not recognized by the GUI, uninstall .NET framework 2.0 and reinstall from the installation CD or Microsoft’s website. The GUI requires .NET Framework 2.0; however, multiple versions such as 1.1, 2.0, and 3.0 may be installed simultaneously.
Initialization	GUI crashes	<ul style="list-style-type: none"> ■ The GUI may crash if a previous GUI .ini file was not removed properly. Close the GUI, and delete all .ini files from the GUI directory. Launch the GUI and try again. ■ If the GUI continues to crash, close the GUI, remove the GUI from Control Panel→Add or Remove Programs, and then delete the GUI directory. Launch the GUI and try again.
Receive	Audio clicking noise	<ul style="list-style-type: none"> ■ Disable "Update" under the "Control" menu (disables continuous GUI/Si47xx updates).
Receive	Excess interference/ Poor Reception	<ul style="list-style-type: none"> ■ If using a laptop, ensure it is running off the battery and not plugged in to the ac mains. ■ Alternatively, disconnect from the host PC and run from battery power. ■ Move to a stronger signal environment.
Receive	Seek/scan doesn't find expected channels	<ul style="list-style-type: none"> ■ Adjust Seek SNR and Seek RSSI thresholds downwards. ■ Verify band and channel spacing for the region.
Receive	Seek/scan stops on noise	<ul style="list-style-type: none"> ■ Adjust Seek SNR and Seek RSSI thresholds upwards. ■ If using a laptop, ensure it is running off the battery and not plugged in to the ac mains.
FM/WB Receive	Poor sensitivity from FM test port	<ul style="list-style-type: none"> ■ Remove ac coupling cap from the headphone input path to eliminate possible sources of interference.

Table 28. Debugging Guidelines for Si47xx EVB

Mode	Symptom	Solution
AM Receive	Excess interference/ Poor reception	<ol style="list-style-type: none"> 1. Check the antenna board connection on J2. 2. Make sure the ferrite bar is not loose and does not slide in the coil. 3. If using a laptop, ensure it is running off the battery and not plugged in. 4. Alternatively, disconnect from the host PC and run from battery power. 5. Move to a stronger signal environment. Make sure you are close to a window or outside in the open when evaluating AM reception. Large metal structures, like buildings, interfere with AM reception so it is best to be away from these sources of interference.
FM Transmit	Audio distorted/Limiter engaging excessively	<ul style="list-style-type: none"> ■ Confirm that audio input levels match the Line Input Attenuation and Maximum Line Input Levels. ■ Disable or scale back the gain of the audio dynamic range control.
FM Transmit	Poor transmit audio quality	<ul style="list-style-type: none"> ■ Increase the RF level. ■ Increase the audio deviation level. ■ Change the RF frequency to a channel with less interference. The RPS feature can be used to find candidate frequencies.

Si47xx-EVB

11. Bill of Materials

Table 29. Si47xx-EVB Baseboard Rev 1.6 Bill of Materials

Item	Qty	RefDes	Description	Value	Mfg/Vendor	Mfg/Vendor_PN
1	1	J78	2.1 mm power plug		CUI	CONN_PJ-01
2	27	C1,C2,C4,C11,C13,C28,C31,C33,C34,C35,C36,C39,C40,C42,C43,C46,C50,C52,C54,C55,C57,C61,C62,C68,C71,C73,C74	CAP,SM,0402,0.1UF,10%	0.1UF	VENKEL	C0402X7R160-104KNE
3	1	C72	RADIAL CAP	4.7UF	Kemet	T350B475K016AS
4	1	C70	CAP,SM,0805	0.1UF		
5	1	C60	CAP,SM,7343,15UF,10%	15UF	VISHAY	293D156X9020D2T
6	6	C18,C21,C22,C38,C69,C77	CAP,SM,0603,1UF,X7R	1UF	VENKEL	C0603X7R100-105KNE
7	2	C20,C41	CAP,SM,0402	24pf	MURATA	GRM1555C1H240JZ01D
8	5	C23,C26,C27,C30,C53	CAP,SM,0402,.01UF,10%,25V	0.01uF	Kemet	C0402C103K3RACTU
9	1	C59	CAP,SM,0402,22PF,10%	22Pf	PANASONIC-ECG	ECJ-0EC1H220J
10	8	C32,C37,C45,C47,C48,C49,C51,C65	CAP,SM,3216,16V	10UF	VISHAY	293D106X9016A2
11	12		CAP,SM,0805	10UF	MURATA	GRM21BR71A106KE51L
12	3	C25,C3,C75	CAP,SM,0402,220PF,5%	220PF	PANASONIC - ECG	ECJ-0EC1H221J
13	1	C58	CAP,SM,3216,10V,10%,6.8UF	6.8UF	EPCOS INC	B45196H2685K109
14	1	C56	CAP,SM,0805,25V,10%,4.7UF	4.7UF	MURATA	GRM21BR61E475KA12L
15	2	C12,C76	CAP,SM,0402,820PF,5%	820pF	MURATA	GRM1555C1E821JA01
16	1	D1	LED,T-1 3/4.RED DIFFUSED		LITEON	LTL-10223W
17	2	FB1,FB2	FERRITE BEAD,SM		STEWART	MI0805K400R-00
18	2	C100,C101	RES,SM,0805	0ohm	VENKEL	CR0805-16W-000T
19	3	J2,J17,J21	Solder jumpers			
20	1	J77	CONN,TH,1X2,HDR		SAMTEC	TSW-102-07-G-S
21	5	J5,J13,J41,J61,J65	CONN,TH,1X3,HDR		SAMTEC	TSW-103-07-G-S
22	1	J62	CONN,TH,2X10,HDR		SAMTEC	TSW-110-07-G-D
23	1	J76	PCB TERMINAL BLOCK, 4 POSITION		MOUSER ELECTRONICS	651-1803293
24	2	J27,J75	CONN,TH,TFM,HDR,2X20,0.05 X0.05IN PITCH		SAMTEC	TFM-120-02-S-D-A
25	2	J24,J54	SMA_VERTICAL		Digikey	ARFX1231-ND
26	2	J32,J51	CONN,TH,1X8,HDR		SAMTEC	TSW-108-07-G-S
27	2	J68,J69	CONN,TH,1X3,HDR \ CONN,TH,1X1,HDR		SAMTEC	TSW-103-07-G-S \ TSW-101-07-G-S
28	2	J6,J7	CONN,RCA,RIGHT ANGLE		CUI	RCJ-2123
29	1	J30	MINIJACK,3.3V,8MBPS		SHARP	GP1FD310TP
30	1	J19	MINIJACK,RCVR,3.3V,8MBPS		SHARP	GP1FD210RP
31	1	J74	HEADER,SHROUDED,5X2		3M	2510-6002UB
32	1	J79	CONN,TH,USB,RCPT,TYPE B		67068-0000	MOLEX/WALDOM ELECTRO
33	1	PB1	BUTTON,SM,LIGHT-TOUCH,160GF,6X3.5MM		PANASONIC - ECG	EVQ-PPBA25

Note: SPDIF will not be supported on new EVBs as of February 14, 2011. On those boards items 29, 30, and 68—silkscreened as J30, J19 and U9—will not be populated.

Table 29. Si47xx-EVB Baseboard Rev 1.6 Bill of Materials (Continued)

Item	Qty	RefDes	Description	Value	Mfg/Vendor	Mfg/Vendor_PN
34	28	R8,R9,R20,R48,R49,R50, R51,R52,R53,R54,R55, R56,R57,R58,R59,R60, R62,R63,R68,R69,R71, R72,R75,R77,R79,R81, R82,R91	RES,SM,0402	0R	VENKEL	CR0402-16W-000T
35	1	R80	RES,SM,0402	22.1	VENKEL	CR0402-16W-22R1FT
36	5	R5,R7,R10,R11,R29	RES,SM,0402	10K	KOA SPEER	RK73H1ELTP1002F
37	2	R12,R13	RES,SM,0402	5.6K	KOA SPEER	RK73H1ELTP5601F
38	1	R43	RES,SM,0402	33	VENKEL	CR0402-16W-330GT
39	4	R17,R27,R36,R19	RES,SM,0402	47K	YAGEO CORPORATION	RC0402FR-0747KL
40	1	R31	RES,SM,0402,300,1%,1/16W	301	YAGEO CORPORATION	9C04021A3010FLHF3
41	1	R38	RES,SM,0402,100,1%,1/16W	100	YAGEO CORPORATION	RC0402FR-07100RL
42	8	R1,R2,R4,R6,R15,R16, R18,R23	RES,SM,0402,160K,5%	160K	VENKEL	CR0402-16W-164JT
43	2	R26,R90	RES,SM,0402,7.32K,1%	7.32K	VENKEL	CR0402-16W-7321FT
44	2	R34,R89	RES,SM,0402,12.7K,1%	12.7K	VENKEL	CR0402-16W-1272FT
45	2	R22,R14	RES,SM,0402,7.68K,1%	7.68K	VENKEL	CR0402-16W-7681FT
46	1	R85	RES,SM,0402	1K	VENKEL	CR0402-16W-102J
47	4	R61,R70,R76,R83	RES,SM,0402	2K	VENKEL	CR0402-16W-202J
48	1	R47	RES,SM,0805	470	VENKEL	CR0805-8W-471J
49	1	R46	RES,SM,0402,1%	51.1K	ROHM	MCR01MZPF5112
50	1	R45	RES,SM,0402,1%	140K	PANASONIC-ECG	ERJ-2RKF1403X
51	1	R44	RES,SM,0402	330K	ROHM	MCR01MZPJ334
52	2	R21,R28	RES,SM,0402	124K	ROHM	MCR01MZPF1243
53	2	R25,R33	RES,SM,0402	39.2K	ROHM	MCR01MZPF3922
54	1	R84	RES,SM,0603	1K	VENKEL	CR0603-10W-1001FT
55	1	R86	VARISTOR,SM,O603		LITTLEFUSE INC	V5.5MLA0603H
56	2	R87,R88	VARISTOR,SM,O402		LITTLEFUSE INC	V0402MHS03
57	1	R24	RES,SM,0402,680,1%,1/16W	681	ROHM	MCR01MZPF6810
58	1	SW1	SWITCH_3PIN		e-switch	eg2472
59	7	U1,U3,U8,U11,U13,U18, U21	SPDT_SWITCH,SC70-6		FAIRCHILD	NC7SB3157P6X
60	1	U17	VOLTAGE_REG,3_3 V,500MA,SOT223		NATIONAL SEMICONDUCT	LM2937IMP-3.3
61	1	U14	OCTAL_BUFFER,TSSOP-20		ST	74LCX541TTR
62	2	U7,U12,	IC,SINGLE_SCHMITT_TRIG- GER_BUFFER		TEXAS_INSTRU- MENTS	SN74LVC1G17DBVR
63	3	U2,U4,U5	IC,SM,OPAMP,SOT23-8		MAXIM	MAX4233AUB
64	1	U16	VOLTAGE_REG,ADJV V,200MA		NATIONAL SEMICONDUCT	LP2986-5.0
65	1	U10	IC,SM,WM8731,WOLFSON,QF N-28		WOLFSON	WM8731
66	1	U6	IC,SM,UHS DUAL SPST,8 LEAD US8		FAIRCHILD SEMI- CONDUCT	FSA266K8X
67	1	U22	IC,SM,C8051F342,MCU,LQFP- 32,9X9MM		SKYWORKS SOLUTIONS	C8051F342GQ

Note: SPDIF will not be supported on new EVBs as of February 14, 2011. On those boards items 29, 30, and 68—silkscreened as J30, J19 and U9—will not be populated.

Si47xx-EVB

Table 29. Si47xx-EVB Baseboard Rev 1.6 Bill of Materials (Continued)

Item	Qty	RefDes	Description	Value	Mfg/Vendor	Mfg/Vendor_PN
68	1	U9	IC,SM,CS8427-DS,SPDIF_TRANSLATOR,28-TSSO		CIRRUS	CS8427-CZ
69	1	X1	32_768 kHz,OSCILLATOR,SM		ECS_INC	ECS-327SMO
70	1	X2	XTAL,12.288MHZ,18PF		CITIZEN AMERICA CORP	CS10-12.288MABJ-UT
71	12	R30,R32,R35,R37,R39,R40,R41,R42,R92,R93,R94,R95	Res,sm,0402	49.9	Venkel	CR0402-16W-49R9FT
72	1	J76	4P Plug 180Deg terminal block		MOUSER ELECTRONICS	651-1803594
73	2	U23, U26	Diode,SM,SD103AW,Shottkey diode		Diodes	SD103AW-7
74	2		Screw Pan 440x3/4		MOUSER ELECTRONICS	561-P440.75
75	2		Spacer nyln rnd 4x.25		MOUSER ELECTRONICS	561-K4.25
76	3		Screw Pan 440x3/8		MOUSER ELECTRONICS	561-P440.375
77	5		1/4 Tapped spacer		MOUSER ELECTRONICS	561-TSP3
78	2		Steel nut, Size 2-56 Width 0.187'		Newark	18M5986
79	2		Steel Screw Head Diameter 0.162', Length 0.25', Size 2-56	Newark	18M6002	
80	4		Nylon Washer, Diameter 0.187', Size #2		Newark	94F9852
81	1		Battery Holder 9 V		MOUSER ELECTRONICS	1BH080
82	1		"I" 6" 26AWG W/SKT 9 V Snap		MOUSER ELECTRONICS	121-0626/M-GR

Note: SPDIF will not be supported on new EVBs as of February 14, 2011. On those boards items 29, 30, and 68—silkscreened as J30, J19 and U9—will not be populated.

Table 30. Si472x-EVB Rev 1.4 Bill of Materials

Item	Qty	RefDes	Description	Value	MFG/Vendor	Mfg/Vendor_PN
1	2	C4,C6	CAP,SM,0402,X7R	22PF	MURATA	GRM185R71E220KA61D
2	1	C2	CAP,SM,0402,X7R	22NF	MURATA	GRM185R71E223KA61D
3	2	C7,C10	CAP,SM,0402,X7R	0.1UF	MURATA	GRM185R71C104KA88D
4	2	C3,C5	CAP,SM,0603,X7R	0.47UF	VENKEL	C0603X7R160-474KNE
5	2	C1,C9	CAP,SM,0603,X7R	1NF	MURATA	GRM185R71E102KA61D
6	3	C11,C12,C13	CAP,SM,0402,X7R	100pF	MURATA	GRM1555C1H101JZ01D
7	2	C14,C15	CAP,SM,0603,X7R	0.33UF	VENKEL	C0603X7R160-334KNE
8	1	C8	RES,SM,0603	2pF	AVX	06035J2R0ABTTR
9	2	J1,J28	SMA,EDGE-MOUNT,GOLD PLATED		YAZAKI	RA2EJ2-6G
10	1	J25	CONN, SM, 2X20, SFM		SAMTEC	SFM-120-02-S-D-A
11	3	J4,J5,J6	CONN, THRU--HOLE, MCX JACK, .100 LAYOUT	NP	DIGI-KEY	J611-ND
12	1	J11	HEADER, 3X12	NP	SAMTEC	TSW-112-07-G-T
13	16	J3,J9,J10,J12,J13, J14,J15,J16,J17, J18,J19,J20,J21, J22,J23,J24	SOLDER BUMP JUMPER, RES, SM, 0402			
14	2	J7,J8	CONN, TH, 1X3, HDR	NP	SAMTEC	TSW-103-07-G-S
15	1	J2	CONN, TH, 1X2, HDR	NP	SAMTEC	TSW-102-07-G-S
16	1	J29	CONN,AUDIO JACK,3.5MM,STEREO		DIGIKEY	CP-3543N-ND
17	3	F1,F2,F3	Ferrite Bead,SM,0603	2500 ohm	MURATA	BLM18BD252SN1D
18	1	L2	IN, SM, 0603	120nH	MURATA	lqw18anr12j00d
19	1	L5	IN, SM, 0603	270NH	MURATA	LQW18ANR27J00D
20	1	L1	IN, SM, 0603	0R	VENKEL	CR0603-16W-000T
21	1	L3	IN, SM, 0603	220nh	MURATA	LQW18ANR22J00D
22	1	R2	RES, SM, 0603	0R	VENKEL	CR0603-16W-000T
23	1	R4	RES, SM, 0603	49.9R	VENKEL	CR0603-16W-49r9T
24	1	R10	RES, SM, 0402	10k	VENKEL	CR0402-16W-103JT
25	1	R1	RES, SM, 0603	10K	VENKEL	CR0603-16W-103JT
26	4	R3,R7,R8,R9	RES, SM, 0402	20K	VENKEL	CR0402-16W-203JB
27	1	R5	RES, SM, 0402	0	VENKEL	CR0402-16W-000T
28	4	R6,R11,R12,R13	RES, SM, 0402	604	VENKEL	CR0402-16W-604R0JB
29	1	U1	IC, SM, SI4720,MLP20 3X3		Skyworks	SI4720
30	1	U2	IC,SM,HEADPHONE AMP		NATIONAL SEMICONDUCTOR	LM4910MA
31	1	U4	IC,SM,ESD PROTECTION DIODE,SOT23-3		CALIFORNIA MICRO DEVICES	CM1213-01ST
32	1	X1	XTAL, SM, 32.768		Epson	FC-135
33	1	A1	4710 RF Daughter Card PCB			

Si47xx-EVB

Table 30. Si472x-EVB Rev 1.4 Bill of Materials (Continued)

Item	Qty	RefDes	Description	Value	MFG/Vendor	Mfg/Vendor_PN
Si471x-EVB Rev 1.4 Population Options						
	1	C10	CAP,SM,0402,X7R	NP		
	2	C1,C9	CAP,SM,0603,X7R	NP		
	3	C11,C12,C13	CAP,SM,0402,X7R	NP		
	2	C14,C15	CAP,SM,0603,X7R	NP		
	1	J28	SMA,EDGE-MOUNT,GOLD PLATED	NP		
	1	J29	CONN,AUDIO JACK,3.5MM,STEREO	NP		
	3	F1,F2,F3	Ferrite Bead,SM,0603	NP		
	1	L5	IN, SM, 0603	NP		
	1	L1	IN, SM, 0603	NP		
	1	L3	RES, SM, 0603	NP		
	1	R10	RES, SM, 0402	NP	VENKEL	CR0402-16W-103JT
	4	R3,R7,R8,R9	RES,SM,0603	NP	VENKEL	CR0603-16W-203JB
	1	U2	IC,SM,HEADPHONE AMP	NP	NATIONAL SEMICONDUCTOR	LM4910MA
	1	U4	IC,SM,ESD PROTECTION DIODE,SOT23-3	NP	CALIFORNIA MICRO DEVICES	CM1213-01ST
Si4705-06-EVB Rev 1.4 Population Options						
	2	C3,C5	RES, SM, 0603	0R	VENKEL	CR0603-16W-000T
	1	C8	RES, SM, 0603	0R	VENKEL	CR0603-16W-000T
	1	R4	RES, SM, 0603	NP	VENKEL	CR0603-16W-000T
	2	R12,R13	RES, SM, 0402	0R	VENKEL	CR0402-16W-000JB

Table 31. Si4731-35-EVB Rev 1.4 Bill of Materials

Item	Qty	RefDes	Description	Value	MFG/Vendor	MFG/Vendor_PN
1	2	C1,C7	CAP,SM,0402,X7R	0.1UF	MURATA	GRM155R71C104KA88D
2	1	C2	CAP,SM,0402,X7R	22NF	MURATA	GRM155R71E223KA61D
3	3	C9,C10,C11	CAP,SM,0402,X7R	100PF	MURATA	GRM1555C1H101JZ01D
4	3	C3,C5,C12	CAP,SM,0603,X7R	1NF	VENKEL	C0603C0G500-103JNE
5	2	C4,C6	CAP,SM,0402,X7R	22PF	VENKEL	C0402C0G500-220JNE
6	2	C8,C13	CAP,SM,0603,X7R	0.47UF		
7	2	C14,C15	CAP,SM,0603,X7R	0.33UF	VENKEL	C0603X7R160-334KNE
8	3	F1,F2,F3	FERRIET,SM,0603	2500ohm	MURATA	BLM18BD252SN1D
9	2	J1,J26	SMA,EDGE-MOUNT,GOLD PLATED		YAZAKI	RA2EJ2-6G
10	1	J2	TERMINAL BLOCK, 12 POSI- TION		SAMTEC	LCW-112-09-S-S-230-RA
11	14	J9,J10,J12,J13,J14,J15,J16,J17,J18, J19,J20,J21,J22,J23	SOLDER BUMP JUMPER, RES, SM, 0402			
12	2	J3,J27,J28	SOLDER BUMP JUMPER, RES, SM, 0402	NP		
13	3	J4,J5,J6	CONN, THRU--HOLE, MCX JACK, .100 LAYOUT	NP	DIGI-KEY	J611-ND
14	2	J7,J8	CONN, TH, 1X3, HDR	NP	SAMTEC	TSW-103-07-G-S
15	1	J11	HEADER, 3X12	NP	SAMTEC	TSW-112-07-G-T
16	1	J24	CONN,AUDIO JACK,3.5MM,STEREO		DIGIKEY	CP-3543N-ND
17	1	J25	CONN,SM,2X20,SFM		SAMTEC	SFM-120-02-S-D-A
18	2	L1	IND,SM,0603	220nH	MURATA	LQW18ANR22J00D
19	2	L2	IND,SM,0603	0 Ω	VENKEL	CR0603-16W-000T
20	1	L4	IND,SM,0603	270nH	MURATA	LQW18ANR27J00D
21	1	L3	IND,SM,0603	NP	MURATA	LQW18ANR12J00D
22	4	R1,R2,R3,R4	RES,SM,0402	20K	VENKEL	CR0603-16W-203JB
23	1	R6	RES,SM,0603	NP		
24	1	R7	RES,SM,0402	10K	VENKEL	CR0402-16W-103JT
25	8	R9,R10,R11,R12,R13,C17,C18,C19	RES,SM,0402	0R	VENKEL	CR0402-16W-000T
26	4	R5,R8	RES,SM,0402	NP		
27	1	C16	RES,SM,0402	604	VENKEL	CR0402-16W-604r0T
28	1	U1	SI4730		Skyworks	4730
29	1	U3	IC,SM,HEADPHONE AMP		NATIONAL SEMI- CONDUCTOR	LM4910MA
30	2	U4,U5	IC,SM,ESD PROTECTION DIODE,SOT23-3		CALIFORNIA MICRO DEVICES	CM1213-01ST

Si47xx-EVB

Table 31. Si4731-35-EVB Rev 1.4 Bill of Materials

Item	Qty	RefDes	Description	Value	MFG/Vendor	MFG/Vendor_PN
31	2	U2,U6	IC,SM,ESD PROTECTION DIODE,SOT23-3	NP	CALIFORNIA MICRO DEVICES	CM1213-01ST
32	1	X1	OSC,SM,Crystal 32.768KHz,Chip	32.768KHz	Epson	FC-135
NP = Not Populated						
Si4707-EVB Rev 1.4 Population Options						
	4	C1,C9,C10,C11	CAP,SM,0402,X7R	NP		
	2	C4,C6	CAP,SM,0402,X7R	NP		
	3	C8,C12,C13	CAP,SM,0603,X7R	NP		
	2	C14,C15	CAP,SM,0603,X7R	NP		
	3	F1,F2,F3	FERRIET,SM,0603	NP		
	1	J1	SMA,EDGE-MOUNT,GOLD PLATED	NP		
	1	J24	CONN,AUDIO JACK,3.5MM,STEREO	NP		
	1	L1	IND,SM,0603	33nh	MURATA	LQW18AN33RJ00D
	1	L2	IND,SM,0603	NP		
	4	R1,R2,R3,R4	RES,SM,0402	NP		
	1	R7	RES,SM,0402	NP		
	1	U3	IC,SM,HEADPHONE AMP	NP		
	1	X1	OSC,SM,Crystal 32.768KHz,Chip	NP		

Table 32. Si474x Daughtercard (Rev 1.3) Bill of Materials

Item	Qty	RefDes	Description	Value	Mfg/Vendor	Mfg/Vendor_pn
1	2	C11,C16	CAP,SM,0402,X7R	NP*		
2	3	C6,C13,C15	CAP,SM,0402,X7R	0.1 μ F	Venkel	C0402X7R160-104JNE
3	2	C1,C19	CAP,SM,0402,X7R	22 nF	Venkel	C0402X7R250-223JNE
4	1	C3	CAP,SM,0402,C0G	270 pF	Venkel	C0402C0G500-271JNE
5	1	C2	CAP,SM,0402,C0G	18 pF	Venkel	C0402C0G500-180JNE
6	3	C5,C8,C9	CAP,SM,0603,X7R	0.47 μ F	Venkel	C0603X7R160-474JNE
7	1	C7	CAP,SM,0402,X7R	1200 pF	Venkel	C0402X7R250-122JNE
8	1	C10	CAP,SM,0402,COG	3.9 pF	Venkel	C0402C0G500-3R9-JNE
9	3	C17,C18,C12	CAP,SM,1206,X5R	100 μ F	Venkel	C1206X7R063-107JNE
10	1	C4	CAP,SM,0603,X7R	0.018 μ F	Venkel	C0402X7R250-183JNE
11	1	C16	CAP,SM,0402,COG	2 pF	Venkel	C0402C0G500-2R0CNP
12	1	J4	BNC,EDGE-MOUNT,GOLD PLATED		Mouser	361V509E
13	18	J1,J2,J6,J7,J8,J9,J10,J12,J13,J15,J16,J17,J18,J19,J20,J22,J24,J27	SOLDER BUMP JUMPER, RES, SM, 0402			
14	2	J21,J23	CONN, TH, 1X4, HDR	NP*		
15	4	J11,J14,J25,J26	CONN, TH, 1X3, HDR	NP*		
16	1	J5	HEADER, 3X12	NP*		
17	1	J28	CONN,SM,2X20,SFM		Samtec	SFM-120-02-S-D-A
18	1	L1	IND,SM,0603	120 nH	Murata	LQW18ANR12J00D
19	1	L2	IND,SM,0603	100 nH	Murata	LQW18ANR10J00D
20	1	L3	IND,SM,1008	220 μ H	Coilcraft	1008PS-224KLB
21	1	L4	IND,SM,4018	1 mH	Coilcraft	LPS4018-105ML
22	2	L6,L7	IND,SM,0805	6.8 μ H	Coilcraft	0805PS-682KB
23	1	L8	IND,TH,7PD	47 mH	Toko	388BN-1211Z
24	1	L9	IND,TH,RFB0807	2.7 mH	Coilcraft	RFB0807-272L
25	1	L10	IND,SM,1008	33 μ H	Coilcraft	1008PS-333KLB
26	1	R3	RES,SM,0402	10 Ω	Venkel	CR0402-16W-100JT
27	1	R8	RES,SM,0402	1 Ω	Venkel	CR0402-16W-1R0JT
28	1	R1	RES,SM,0603	10 M Ω	Venkel	CR0603-16W-106JT
29	3	C14,R21,R24	RES,SM,0402	0 Ω	Venkel	CR0402-16W-000T
30	1	R11	RES,SM,0402	10 k Ω	Venkel	CR0402-16W-103JT
31	1	L5	RES,SM,0603	150 nH	Murata	LQW18ANR15J00D
32	4	R22,R23	RES,SM,0402	4.02 k Ω	Venkel	CR0402-16W-4021FT
33	1	R2	RES,SM,0402	24.3 K	Venkel	CR0402-16W-2432FT
34	1	R13	RES,SM,0402	4.53 K	Venkel	CR0402-16W-4531FT

Si47xx-EVB

Table 32. Si474x Daughtercard (Rev 1.3) Bill of Materials (Continued)

Item	Qty	RefDes	Description	Value	Mfg/Vendor	Mfg/Vendor_pn
35	1	R16	RES,SM,0402	604 Ω	Venkel	CR0402-16W-6040FT
36	3	R5,R18,R19	RES,SM,0402	4.7 k Ω	Venkel	CR0402-16W-472JT
37	5	R4,R6,R7,R9,R10	RES,SM,0402	249 Ω	Venkel	CR0402-16W-2490FT
38	3	R12,R14,R15	RES,SM,0402	NP*		
39	2	R17,R20	RES,SM,0402	22 k Ω	Venkel	CR0402-16W-223JT
40	1	Q6	FET,SM,SOT-23		Fairchild Semi	2N7002
41	2	Q1,Q2	FET,SM,SOT-23		NXP	BF862
42	2	Q3,Q4	TRANSISTOR,NPN,,SM, SOT-23		Fairchild Semi	MMBTH10
43	1	Q5	TRANSISTOR,PNP,SM, SOT-23		Fairchild Semi	MMBTH81
44	1	U1	IC,SM,QFN4X4 24P		Skyworks	Si474X
45	2	U2,U4	IC,SM,ESD PROTECTION DIODE,SOT23-3		California Micro Devices	CM1213-01ST
46	1	U3	IC,SM,QUAD NORGATE,TSOP- 14		TI	74LVC02APW
*Note: NP = Not Populated						

Table 33. Si4749 Daughtercard (Rev 1.1) Bill of Materials

Item	Qty	RefDes	Description	Value	Mfg/Vendor	Mfg/Vendor_pn
1	3	C4,C6,C7	CAP,SM,0402,X7R	0.1 μ F	Venkel	C0402X7R160-104JNE
2	1	C2	CAP,SM,0402,X7R	22 nF	Venkel	C0402X7R250-223JNE
3	2	C4,C6	CAP,SM,0402,C0G	24 pF	Venkel	C0402C0G500-240JNE
4	1	C1	CAP,SM,0402,C0G	100 pF	Venkel	C0402C0G500-101JNE
5	1	C8	CAP,SM,0402,X7R	NP*		
6	2	C3,C5	CAP,SM,0402,COG	0.01 μ F	Venkel	C0402X7R250-103JNE
7	1	J1,J2	SMA,EDGE-MOUNT,GOLD PLATED		Yazaki	RA2EJ2-6G
8	14	J9,J10,J12,J13,J14,J 15,J16,J17,J18,J19,J 20,J21,J22,J23	SOLDER BUMP JUMPER, RES, SM, 0402			
9	2	J27,J28	SOLDER BUMP JUMPER, RES, SM, 0402	NP*		
10	3	J4,J5,J6	CONN, THRU--HOLE, MCX JACK, .100 LAYOUT	NP*	Digi-Key	J611-ND
11	2	J7,J8	CONN, TH, 1X3, HDR	NP*	SAMTEC	TSW-103-07-G-S
12	1	J11	HEADER, 3X12	NP*	SAMTEC	TSW-112-07-G-T
13	1	J25	CONN,SM,2X20,SFM		SAMTEC	SFM-120-02-S-D-A
14	1	L1	IND,SM,0603	180 nH	Murata	LQW18ANR18J00D
15	1	L2	IND,SM,0603	NP		
16	1	R1	RES,SM,0603	10 M Ω	Venkel	CR0603-16W-106T
17	2	R2,R4	RES,SM,0402	64.9 Ω	Venkel	CR0402-16W-64R9FT
18	6	R3,R7,R9	RES,SM,0402	0 Ω	Venkel	CR0402-16W-000T
19	2	R6,R10	RES,SM,0402	2 k Ω	Venkel	CR0402-16W-202T
20	1	R5	RES,SM,0402	604 Ω	Venkel	CR0402-16W-604R0T
21	1	R9,,R11	RES,SM,0402	10 Ω	Venkel	CR0402-16W-100JT
22	1	R8	RES,SM,0402	NP*		
23	2	Q1,Q2	FET,SM,SOT-23		NXP	BF862
24	1	U2	SI4749		Skyworks	Si4749
25	1	U1	IC,SM,ESD PROTECTION DIODE,SOT23-3		California Micro Devices	CM1213-01ST
	1	A1	PCB,Si4749EVB		Skyworks	

*Note: NP = Not Populated

Si47xx-EVB

Table 34. Si4730 Ferrite Medium Antenna Rev 1.2 Bill of Materials

Item	Qty	RefDes	Description	Value	Mfg/Vendor	Mfg/Vendor_PN
1	1	J4	Socket Header, TH, Friction notch		SAMTEC	SSW-112-02-G-P-RA
2	1	U1	Medium Ferrite Core		Skyworks	SL4X30MW110T
3	1	A1	PCB, Ferrite Antenna Board			
4	1		Zip Tie 6in		Hellermann Tyton	T30R9C2

NP = Not Populated

Table 35. Si473x Ferrite Large Antenna Rev 1.2 Bill of Materials

Item	Qty	RefDes	Description	Value	Mfg/Vendor	Mfg/Vendor_PN
1	1	J4	Socket Header, TH, Friction notch		SAMTEC	SSW-112-02-G-P-RA
2	1	U1	Large Ferrite Core		Skyworks	SL5X7X100MW70T
3	1	A1	PCB, Ferrite Antenna Board			
4	2		Zip Tie 6in		Hellermann Tyton	T30R9C2

Table 36. Si473x Airloop Antenna Rev 1.2 Bill of Materials

Item	Qty	RefDes	Description	Value	Mfg/Vendor	Mfg/Vendor_PN
1	1	J1	Compression Connector (Speaker jack)		KOBI(Mouser)	151-0300-E
2	1	J2	Socket Header, TH, Friction notch		SAMTEC	SSW-112-02-G-P-RA
3	1	U1	Transformer, TH, Custom		Skyworks	SL9X5X4MWTF
4	1	A1	PCB, Air Loop Antenna Board			

NP = Not Populated

Table 37. Si473x SW/WB Antenna Bill of Materials

Item	Qty	RefDes	Description	Value	Mfg/Vendor
1	1	C1	CAP,SM,0402,C0G	18 pF	VENKEL
2	1	C2	CAP,SM,0402,C0G	33 pF	VENKEL
3	1	J1	Socket Header, TH, Friction notch		SAMTEC
4	1	J2	BNC,EDGE-MOUNT, GOLD PLATED		MOUSER
5	1	J3	Large Ferrite Core		Skyworks
6	1	L1	IND,SM,0603	470 nH	MURATA
7	1	L2	IND,SM,1008	4.7 μ H	COILCRAFT
8	1	S1	SPDT Sw itch		E-switch
9	1	U1	IC,SM,ESD PROTECTION DIODE, SOT23-3		CALIFORNIA MICRO DEVICES
10	1	A1	PCB, Short Wave Antenna Board		
11	2	X1, X3	Zip Tie 6in		Hellerman Tyton
NP = Not Populated					
Population Options					
Weather Band Antenna Card		C1 and C2	RES, SM, 0402	0	VENKEL
		L1	IND, SM, 0603	68 nH	MURATA
		L2		NP	
		S1		NP	
NP = Not Populated					

Table 38. Si474x Antenna Dummy Card Rev 1.0 Bill of Materials

Item	Qty	RefDes	Description	Value	Mfg/Vendor	Mfg/Vendor_PN
1	1	C1	CAP,SM,0603,C0G	15 pF	VENKEL	C0603C0G500-150JNE
2	1	C2	CAP,SM,0603,C0G	15 pF	VENKEL	C0603C0G500-620JNE
3	2	J1, J2	SMA,EDGE-MOUNT, GOLD PLATED	62 pF	MURATA	RA2EJ2-6G
4	1	R1	RES,SM,0603	49.9 R	VENKEL	CR0603-16W-490T
NP = Not Populated						

Si47xx-EVB

12. Schematics

12.1. Si47xx-EVB Baseboard Rev 1.6

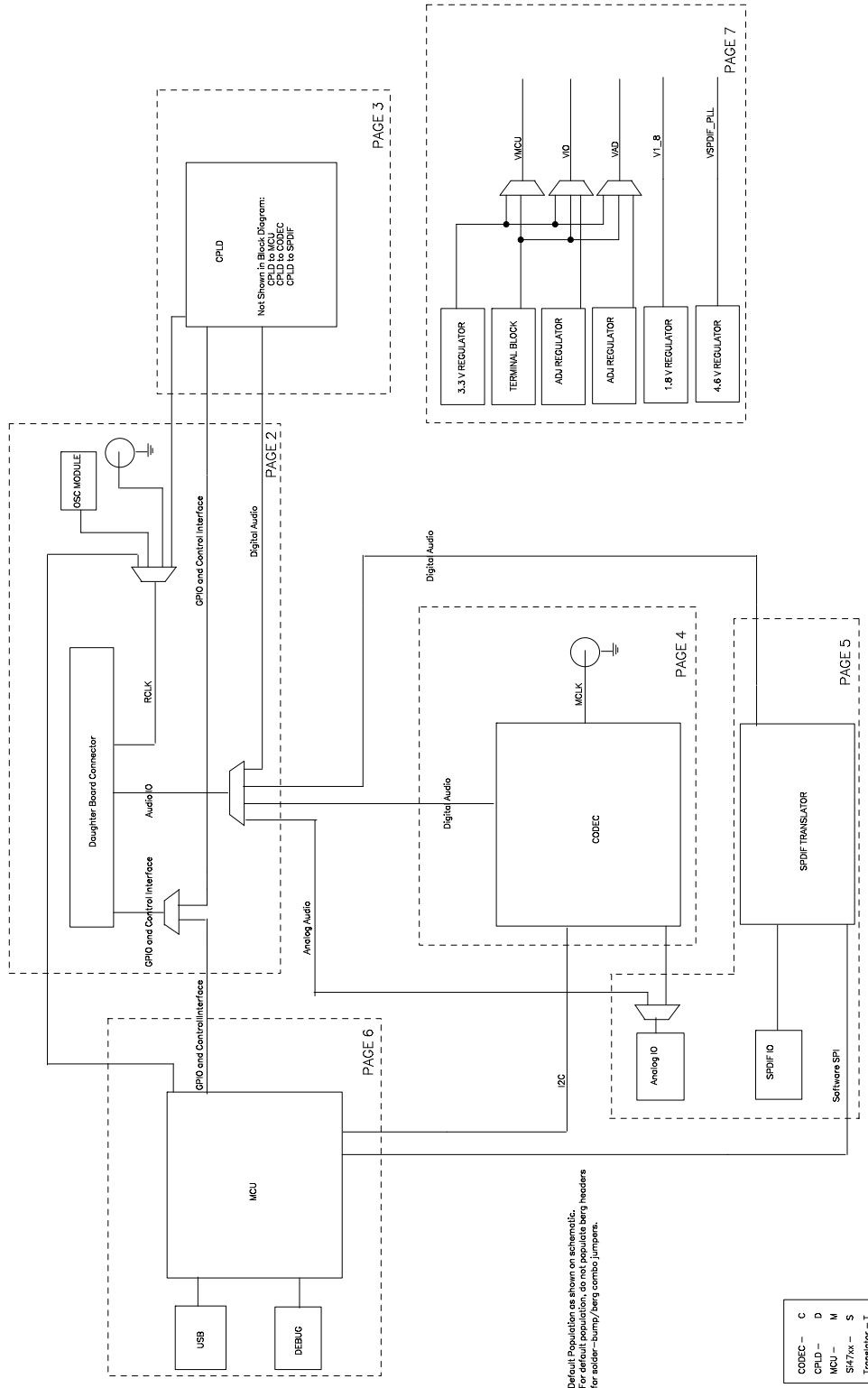

Figure 84. Si47xx-EVB Baseboard Rev 1.6 Block Diagram

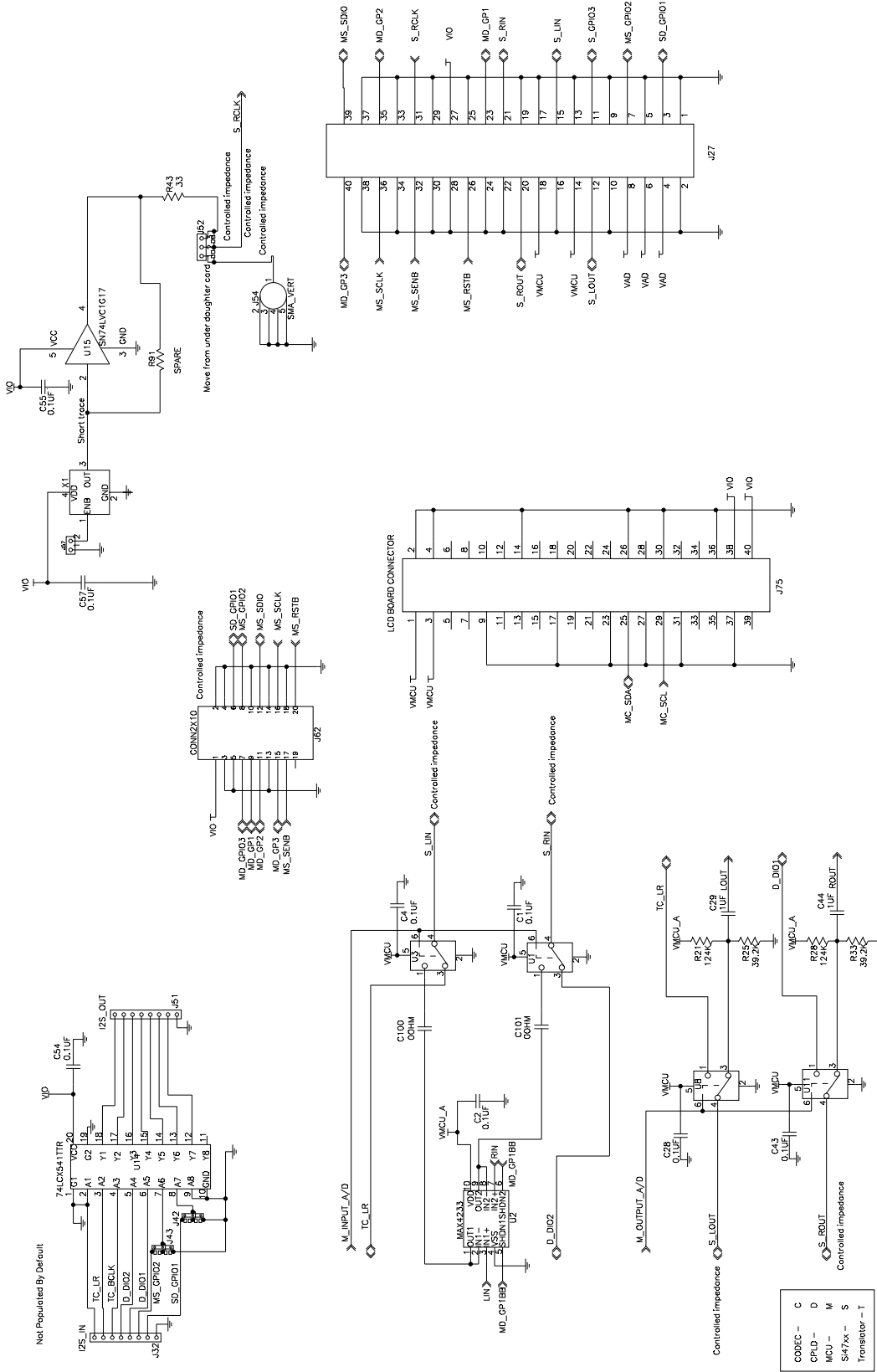

Figure 85. Si47xx-EVB Baseboard Rev 1.6 Daughtercard Interface

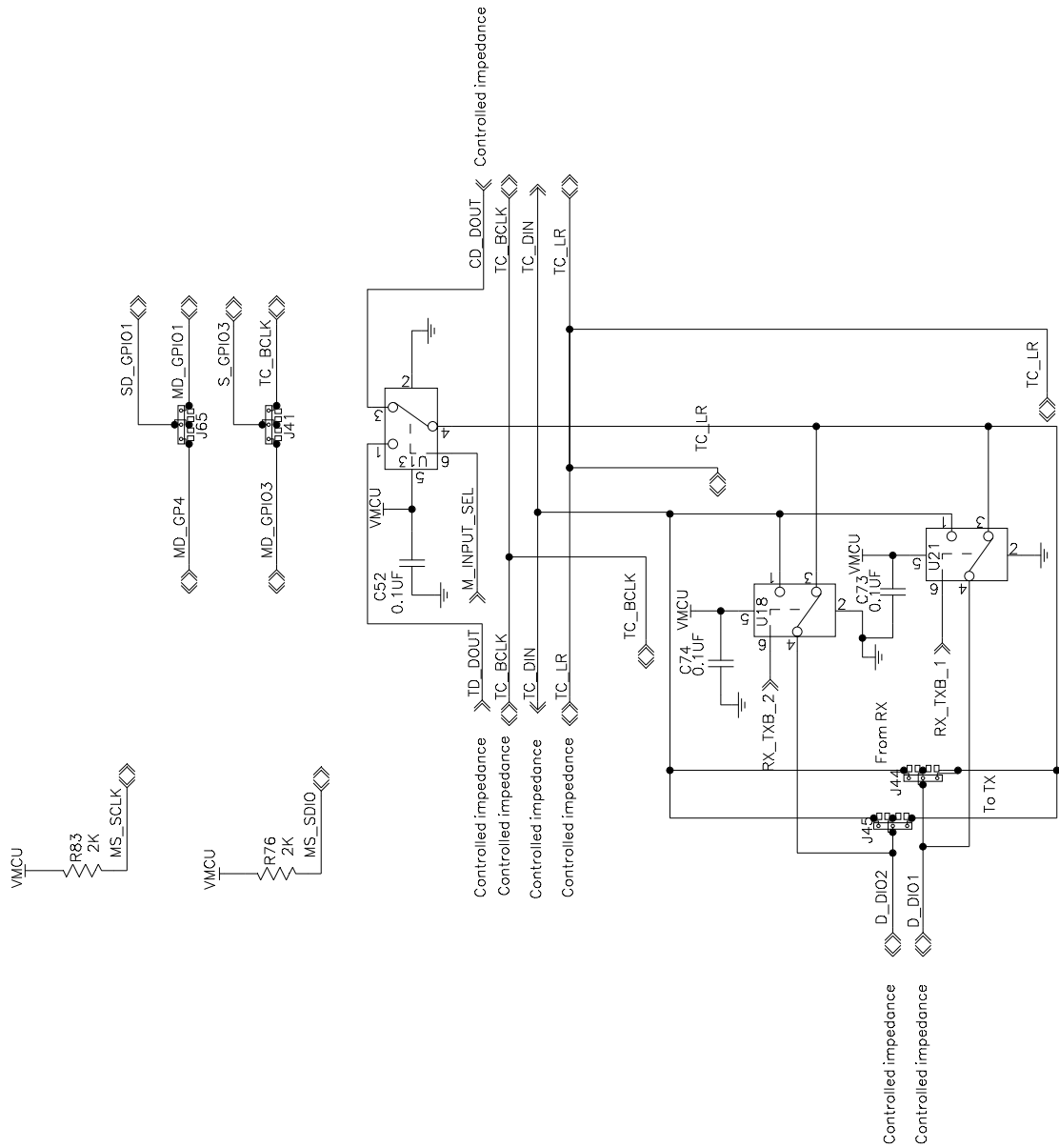

Figure 86. Si47xx-EVB Baseboard Rev 1.6 Signal Multiplexers

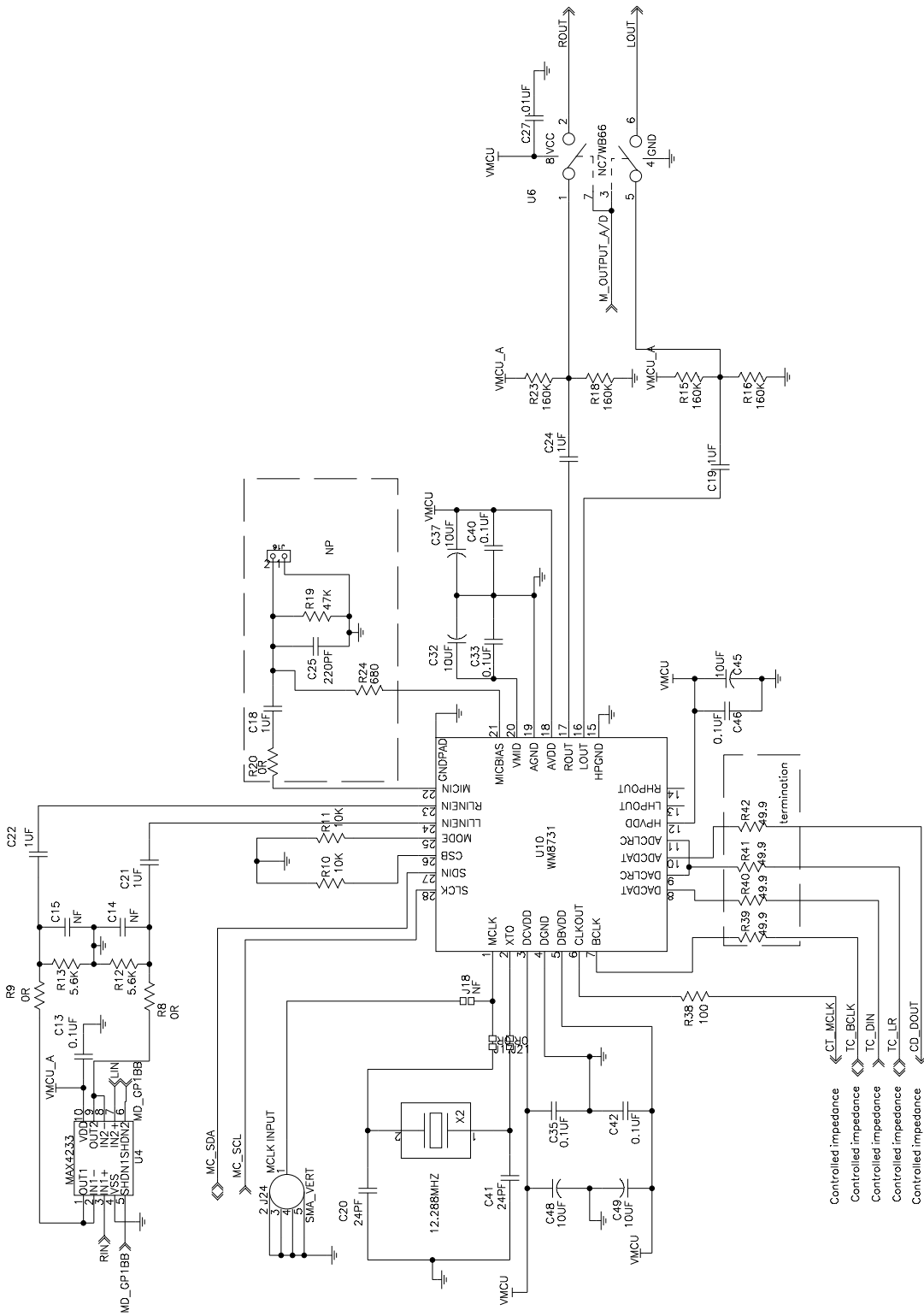

Figure 87. Si47xx-EVB Baseboard Rev 1.6 CODEC

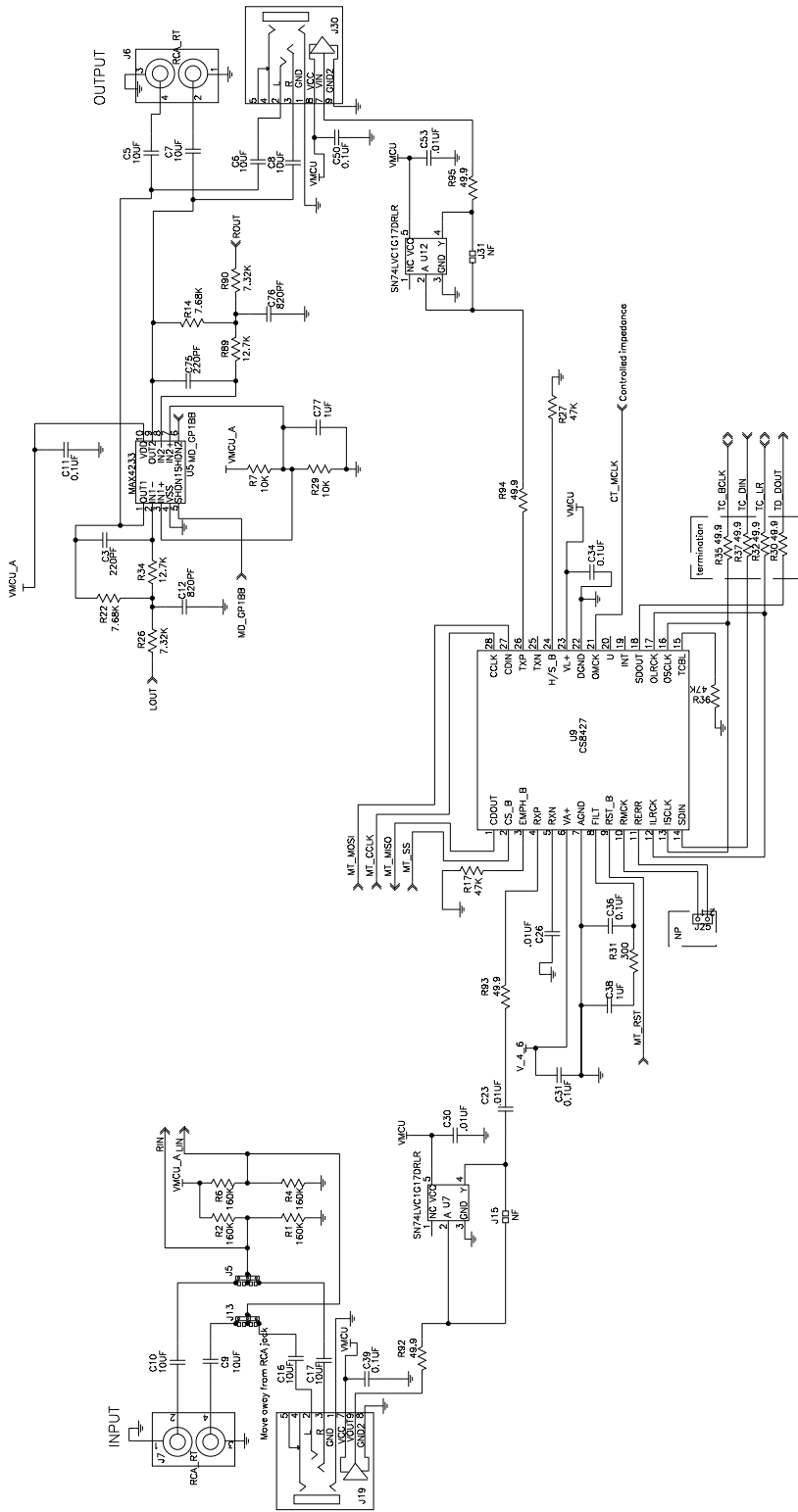

Figure 88. Si47xx-EVB Baseboard Rev 1.6 Audio Input and SPDIF Translator

Note: For EN55020 compliance, please add the following components to L-OUT and R-OUT @ J6: 1 μ F from C5 x C7 to GND (one for each output), 22.6 Ω in series with C5 x C7 (one for each output).

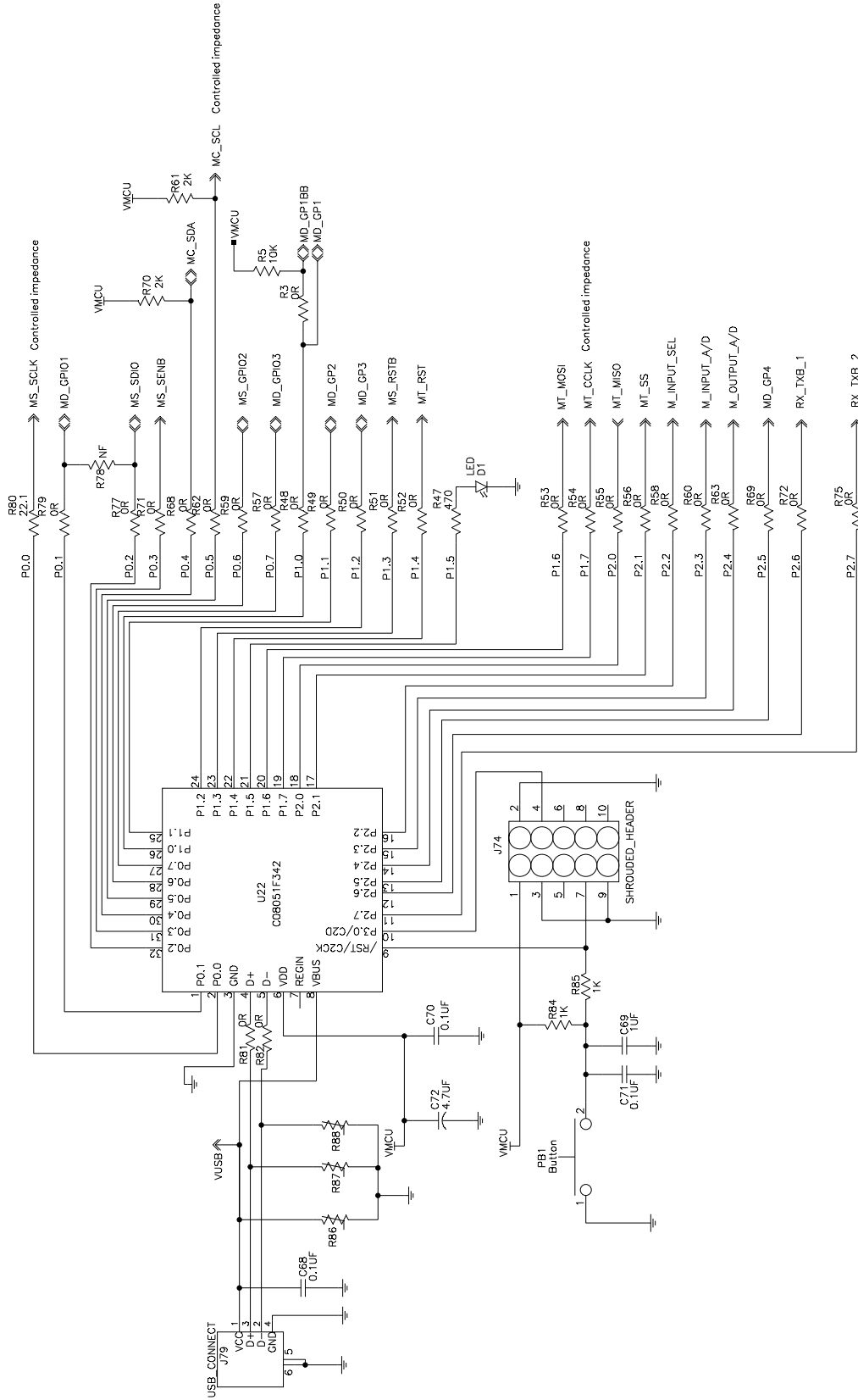

Figure 89. Si47xx-EVB Baseboard Rev 1.6 MCU

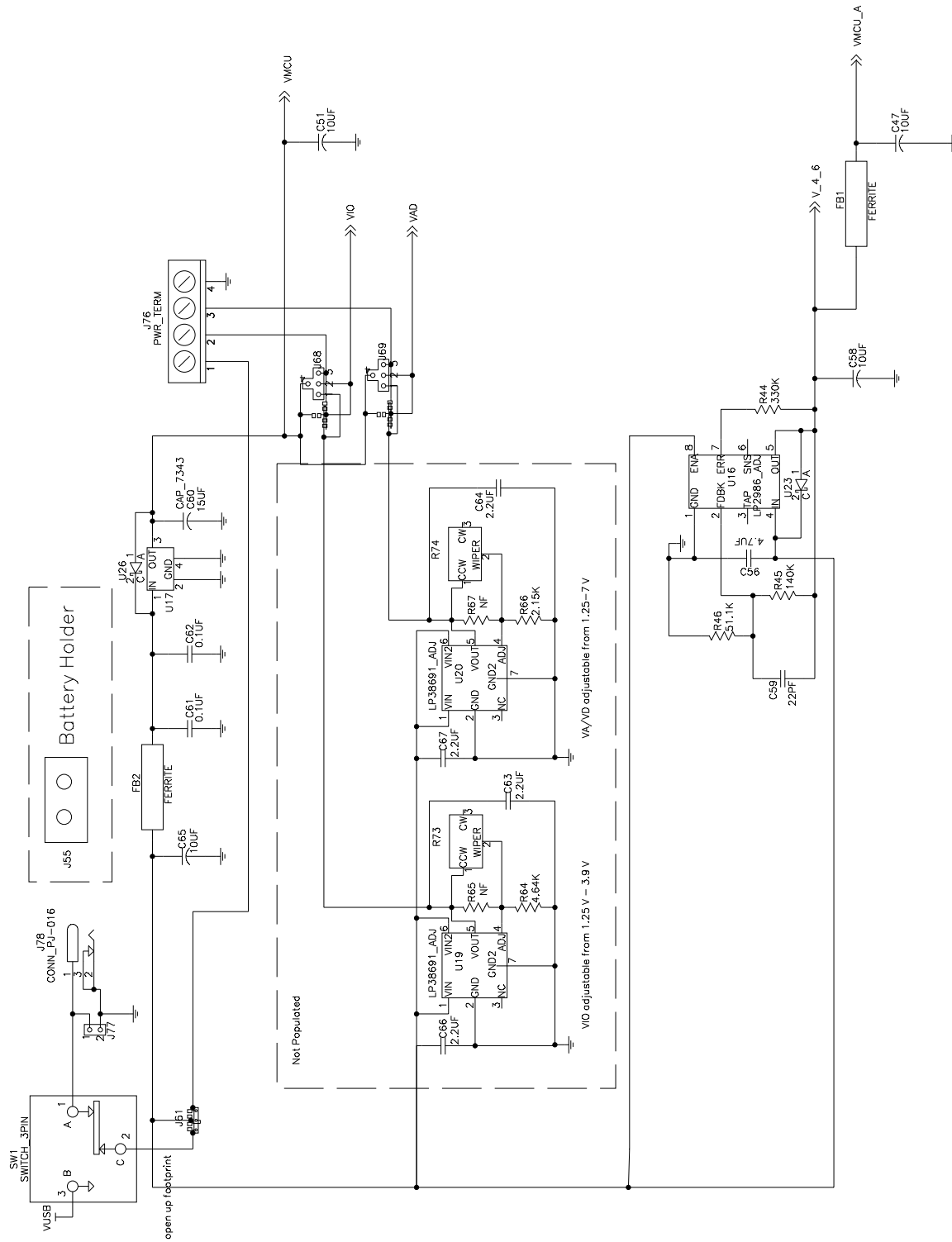

Figure 90. Si47xx-EVB Baseboard Rev 1.6 Power Supply

12.2. Si471x/2x-EVB Daughtercard Rev 1.4

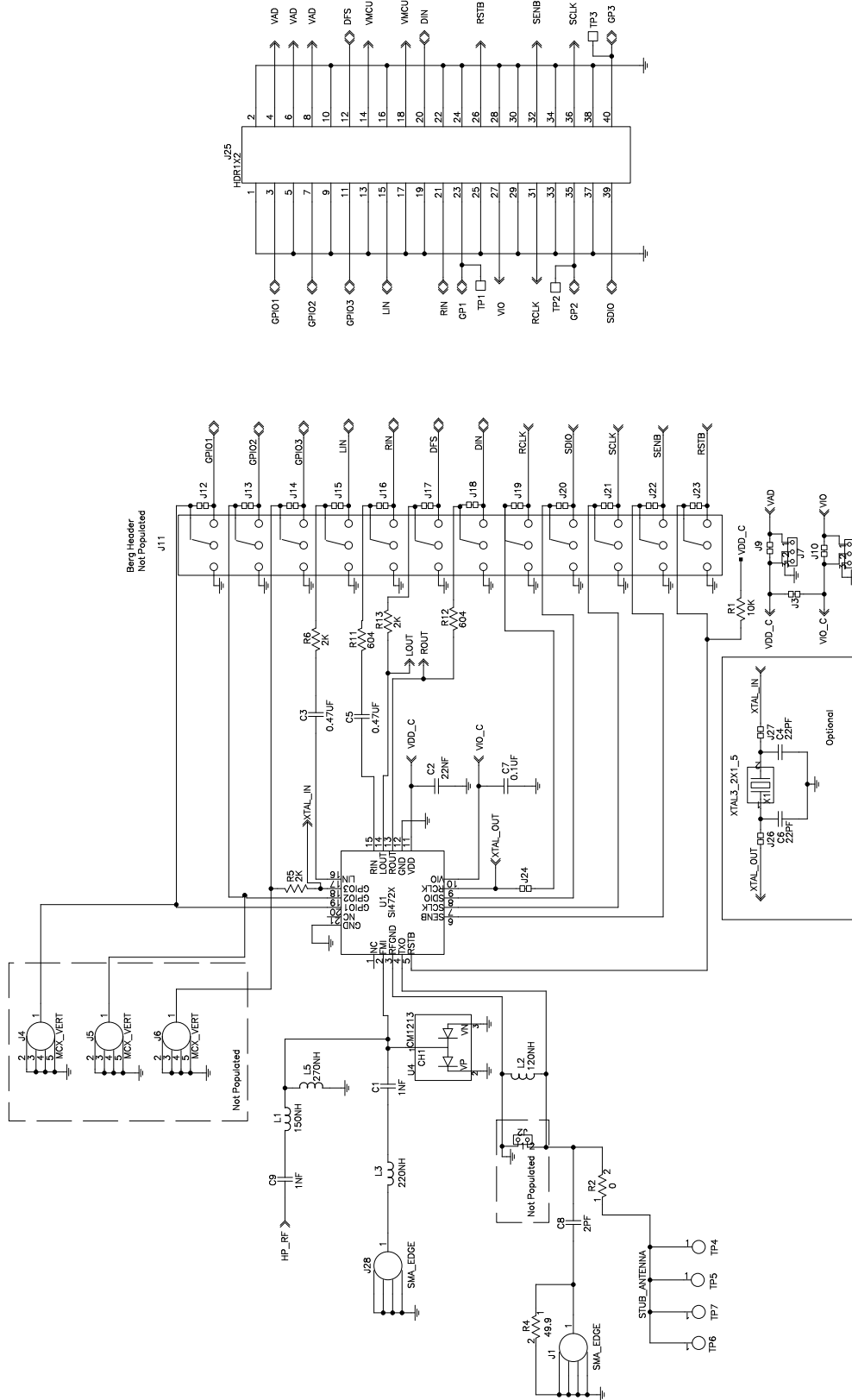
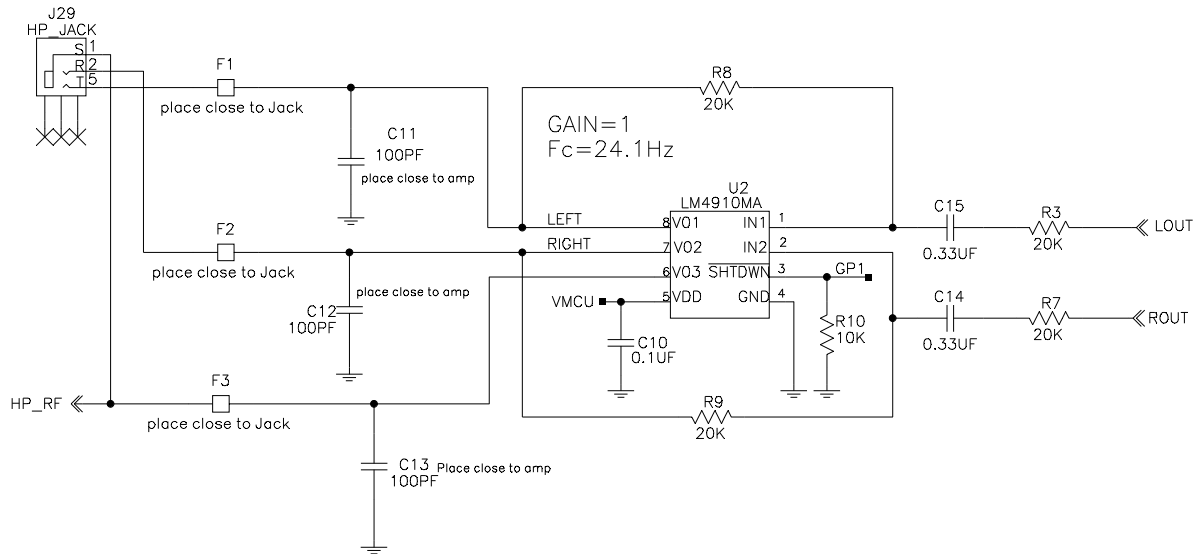

Figure 91. Si471x/2x-EVB Daughtercard (Rev 1.4)

Si47xx-EVB



**Figure 92. Si471x/2x-EVB Daughtercard (Rev 1.4) Headphone Schematic
(applies only to Si4704/05/06/2x/8x)**

Si471x/2x-EVB Daughtercard (Rev 1.4) ships configured for external RCLK, supplied by the Si47xx-EVB Baseboard. To configure for crystal oscillator operation:

1. Remove R5.
2. Remove short at J24.
3. Short J26.
4. Short J27.
5. Select "Use XOSCEN" at GUI initialization.

Note: Digital Audio Output is not available when configured for crystal oscillator.

Si47xx-EVB

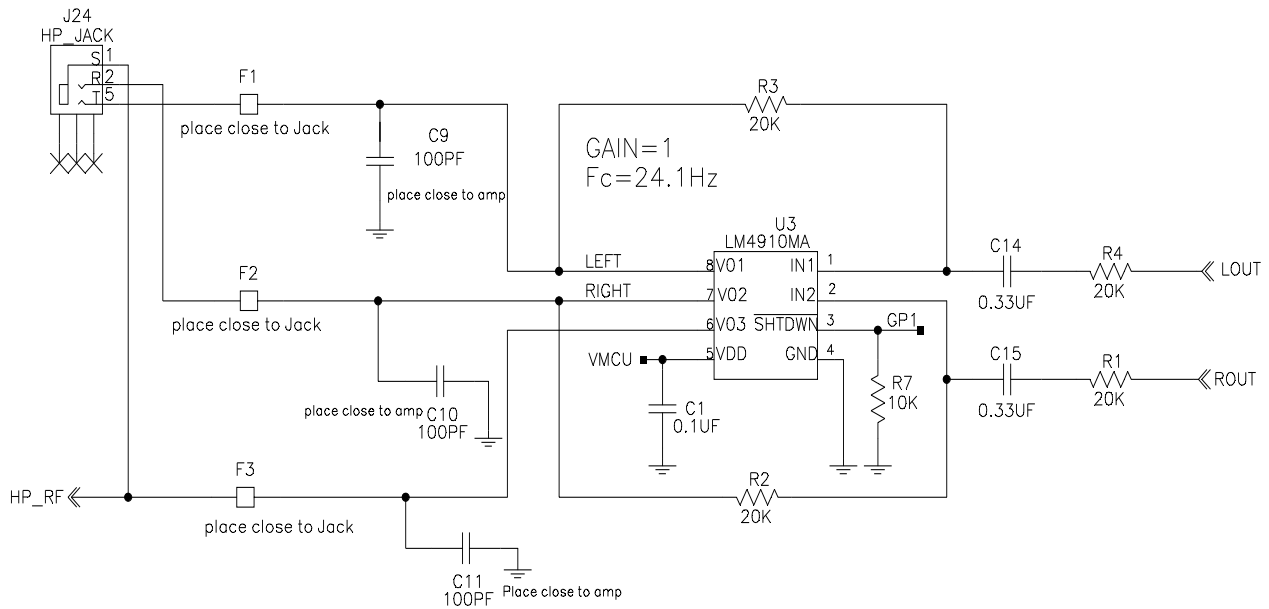

Figure 94. Si473x-EVB Daughtercard Rev 1.4 (2 of 2)

Si473x-EVB Daughtercard (Rev 1.4) ships configured for external RCLK, supplied by the Si47xx-EVB Baseboard. To configure for crystal oscillator operation:

1. Remove R9.
2. Remove R10.
3. Short J27.
4. Short J28.
5. Select "Use XOSCEN" at GUI initialization.

Note: Digital Audio Output is not available when configured for crystal oscillator.

12.4. Si474x-EVB Daughtercard Rev 1.3

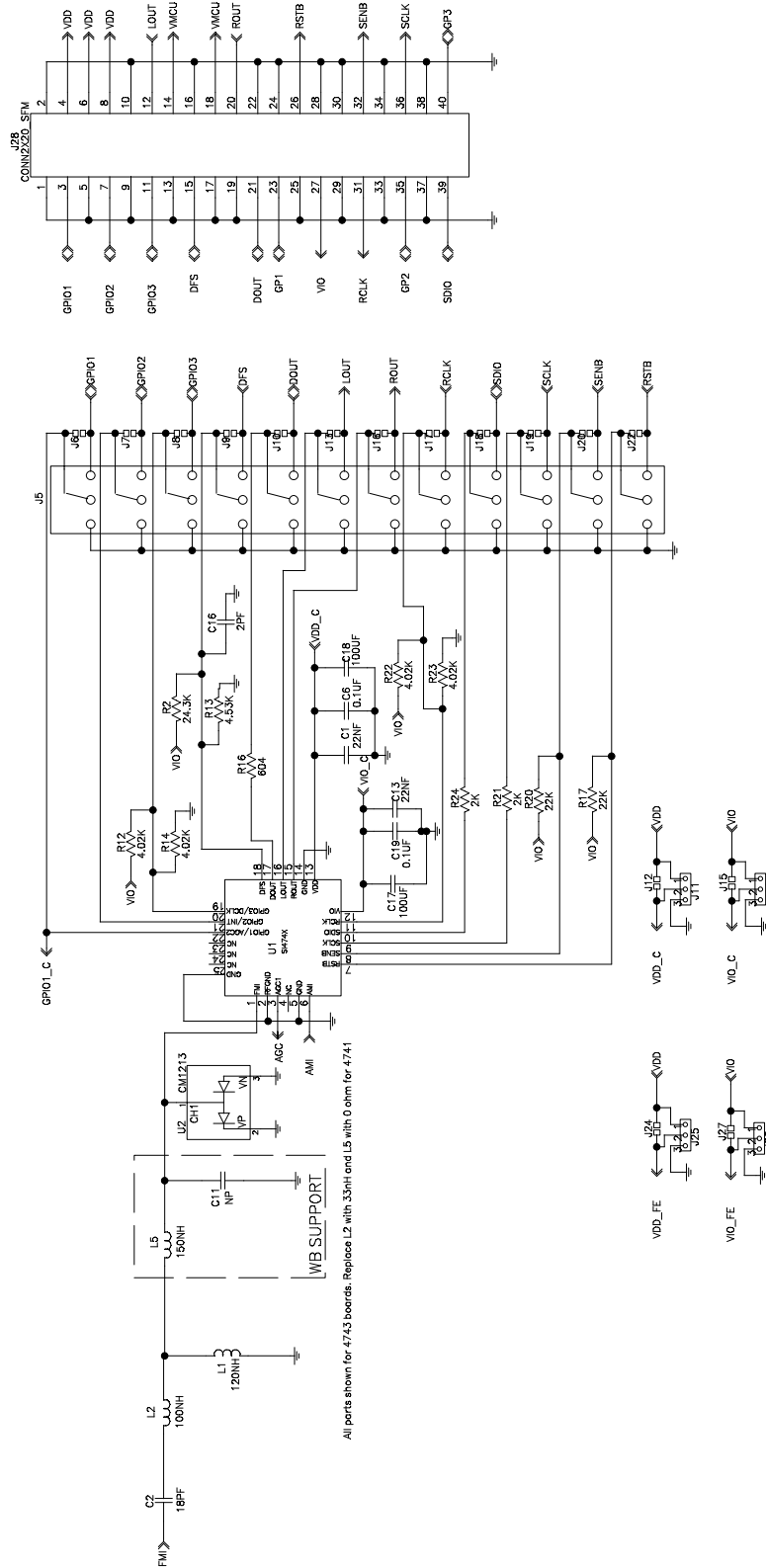

Figure 95. Si474x-EVB Daughtercard Rev 1.3 (1 of 2)

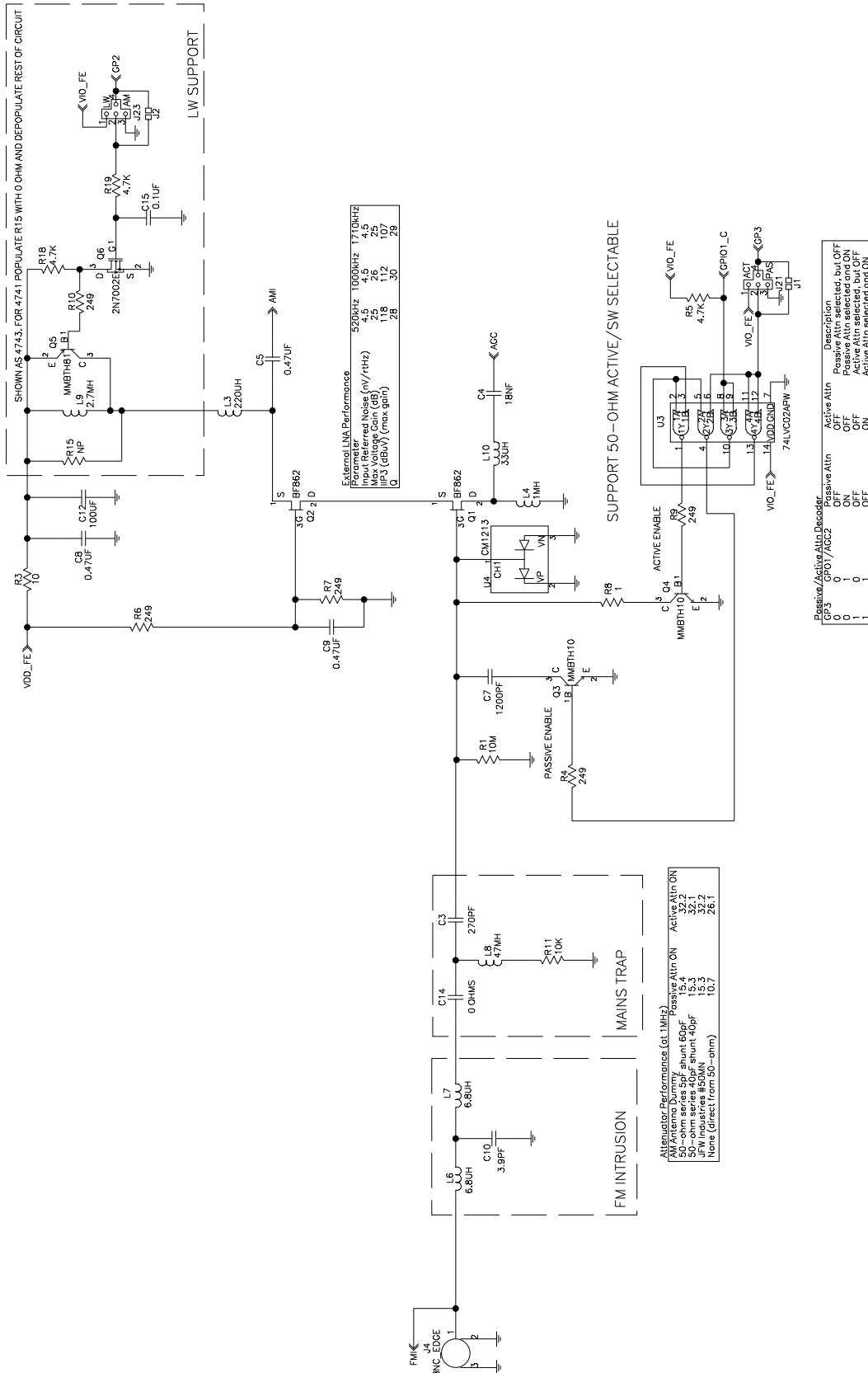

Figure 96. Si474x-EVB Daughtercard Rev 1.3 (2 of 2)

12.5. Si4749-EVB Daughtercard Rev 1.1

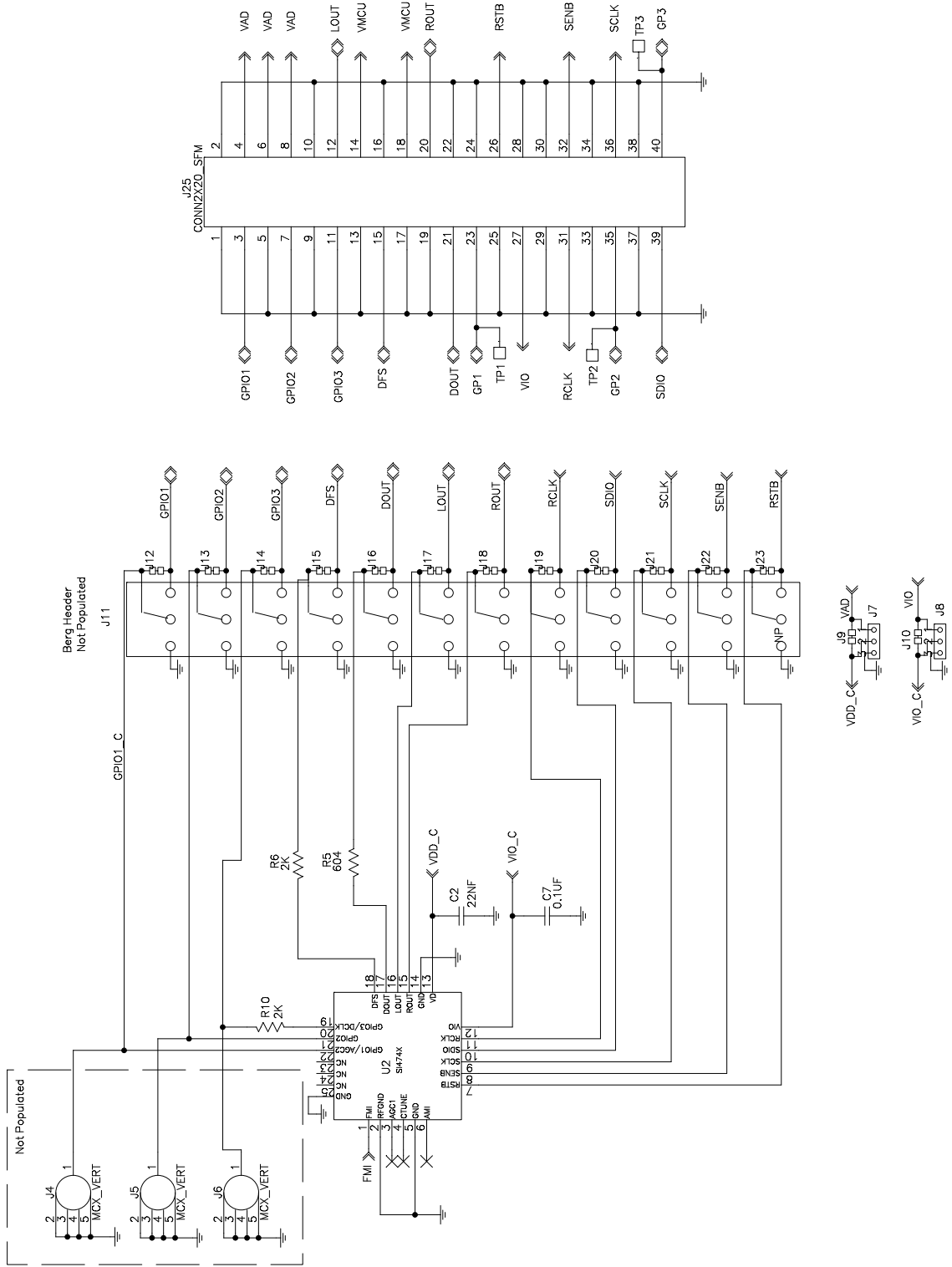

Figure 97. Si4749-EVB Daughtercard Rev 1.1 (1 of 2)

Si47xx-EVB

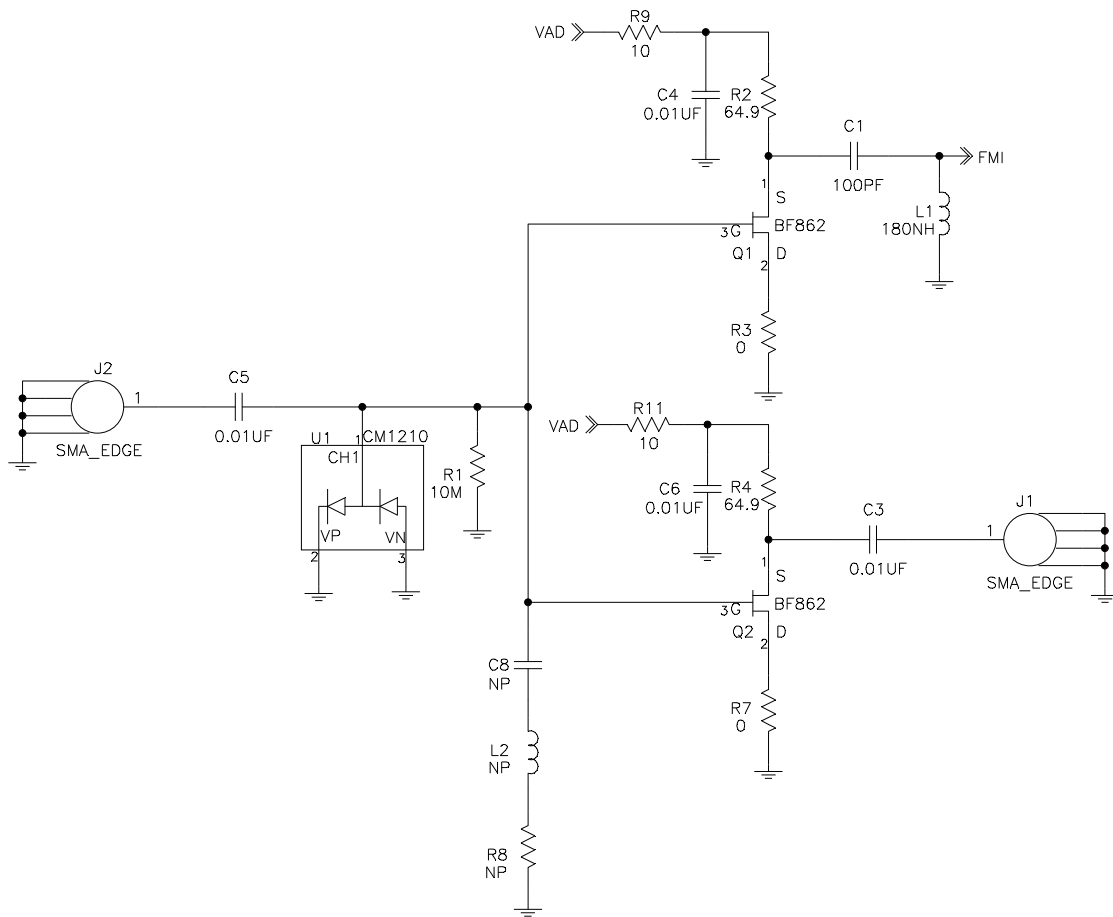

Figure 98. Si4749-EVB Daughtercard Rev 1.1 (2 of 2)

Note: C4, C6, R9, and R11 manually added to Si4749EVB Rev 1.0 to create Si4749EVB Rev 1.1.

12.6. Antenna Card Schematics

12.6.1. Si473x Ferrite Antenna Card Rev 1.2

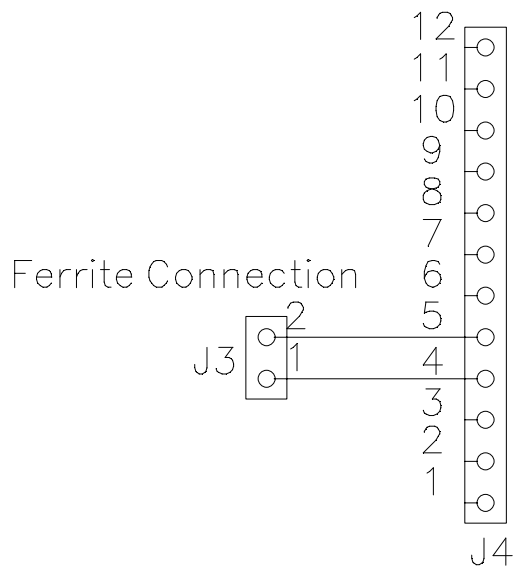

Figure 99. Ferrite Antenna Card Rev 1.2

12.6.2. Si473x Air Loop Antenna Card Rev 1.2

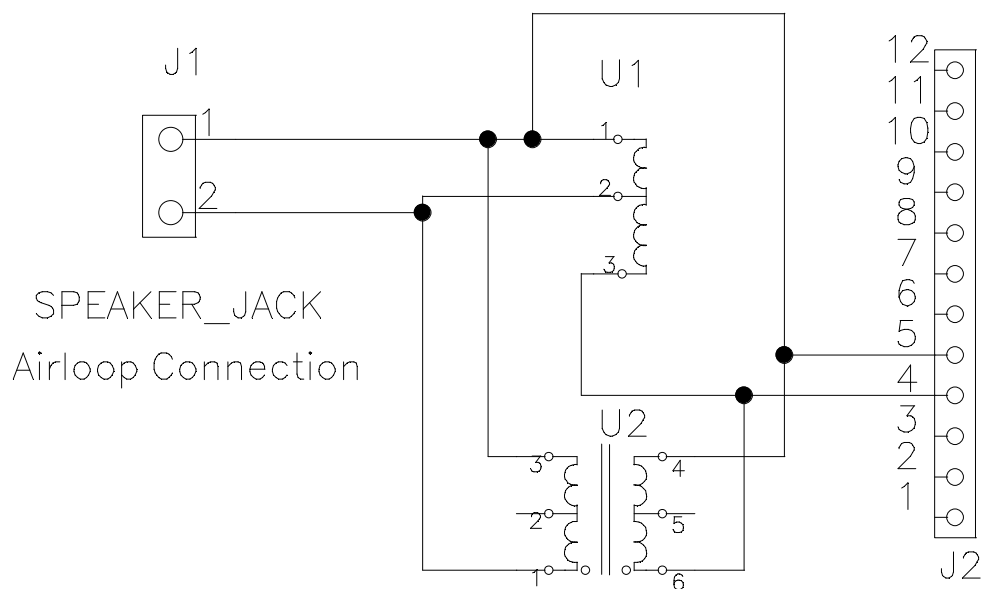
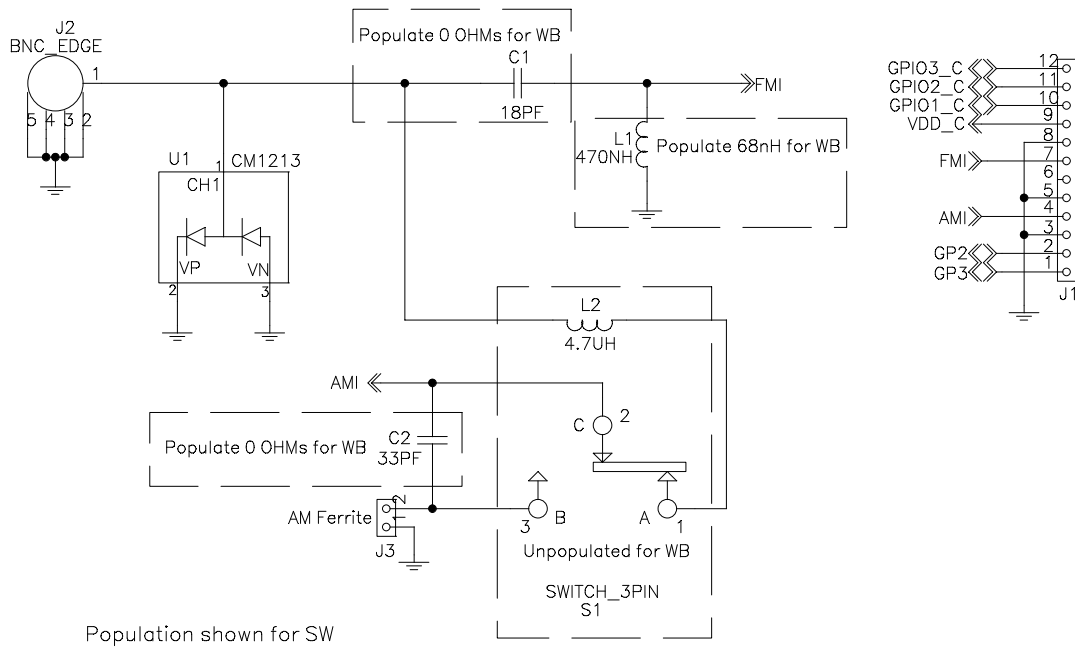

Figure 100. Airloop Antenna Card Rev 1.2

Si47xx-EVB

12.6.3. Si473x SW/WB Antenna Card Rev 1.3



Note: If an SW band is selected using the SW/WB Antenna Card, set the varactor to 1 for best performance. LW not supported with SW/WB Antenna Card.

Figure 101. Si473x SW/WB Antenna Card Rev 1.3

12.6.4. Si474x Antenna Dummy Card Rev 1.0

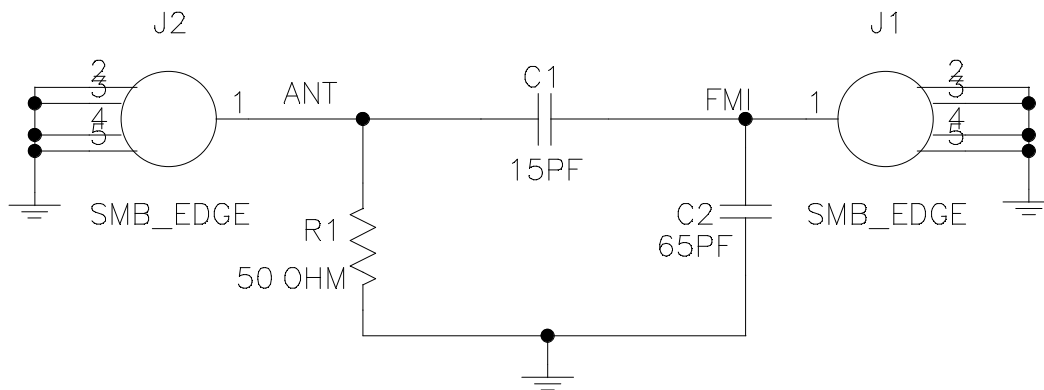

Figure 102. Si474x Antenna Dummy Card Rev 1.0

13. Layout

13.1. Si47xx-EVB Baseboard Rev 1.6

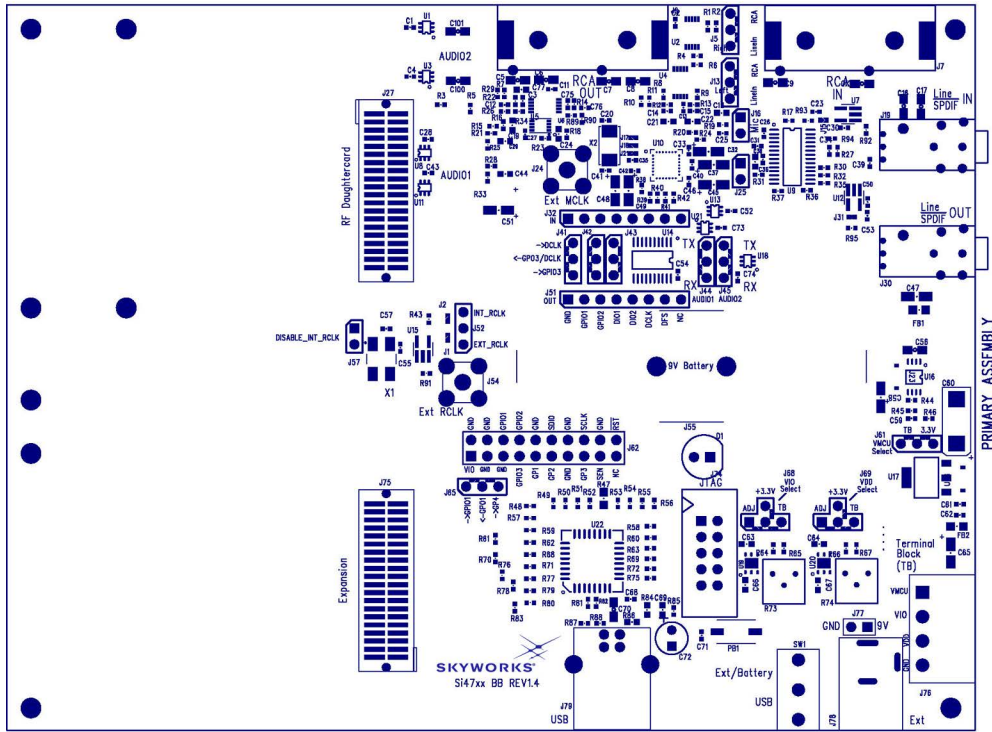

Figure 103. Si47xx-EVB Baseboard Rev 1.6—Primary Assembly Silkscreen

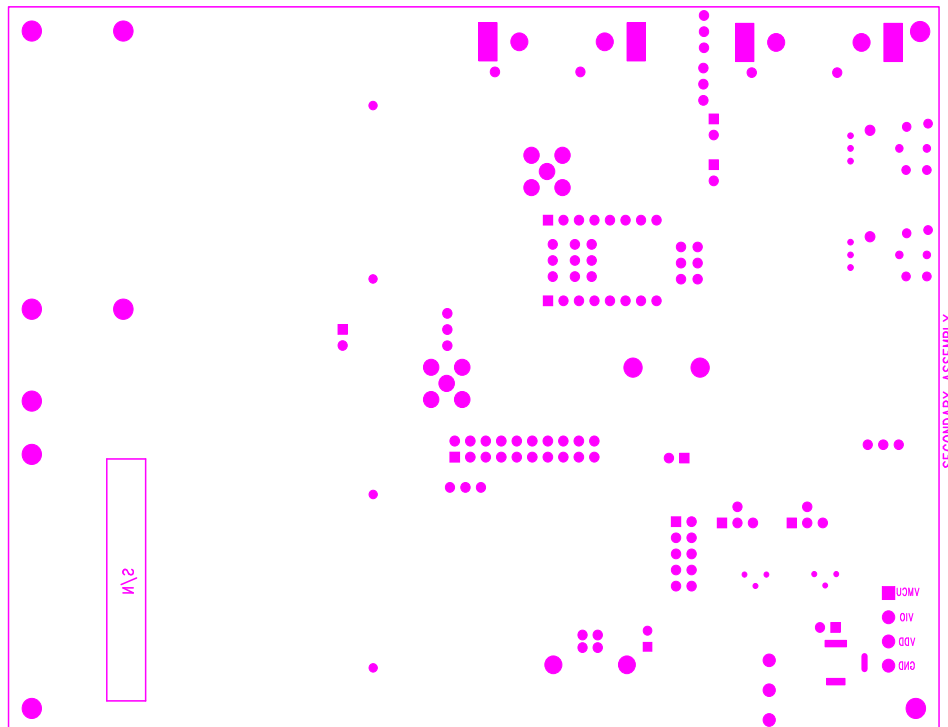

Figure 104. Si47xx-EVB Baseboard Rev 1.6—Secondary Assembly Silkscreen

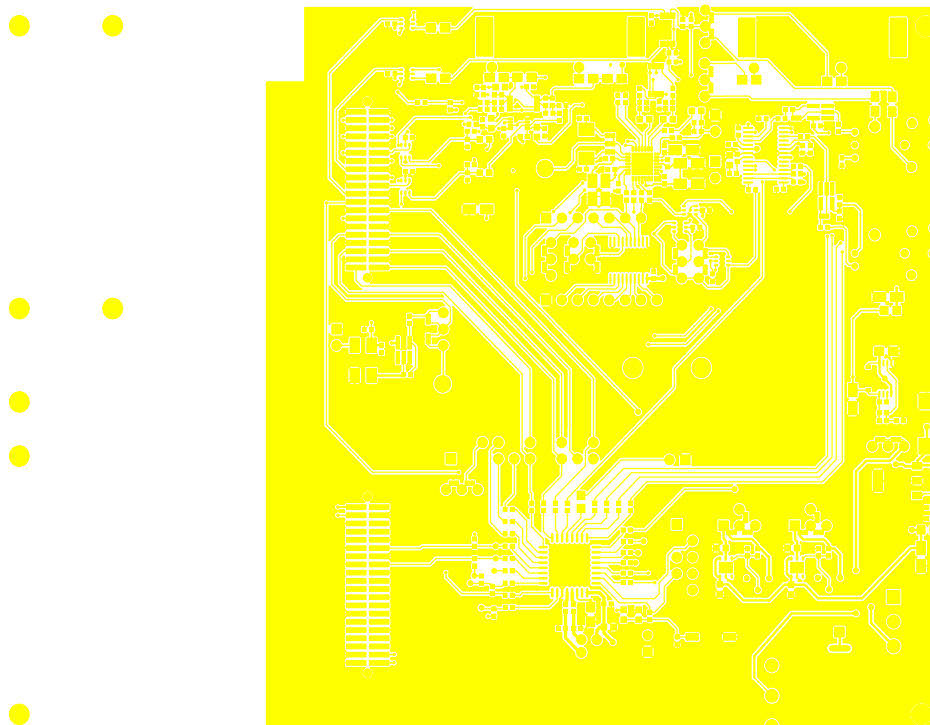

Figure 105. Si47xx-EVB Baseboard Rev 1.6—Primary Side

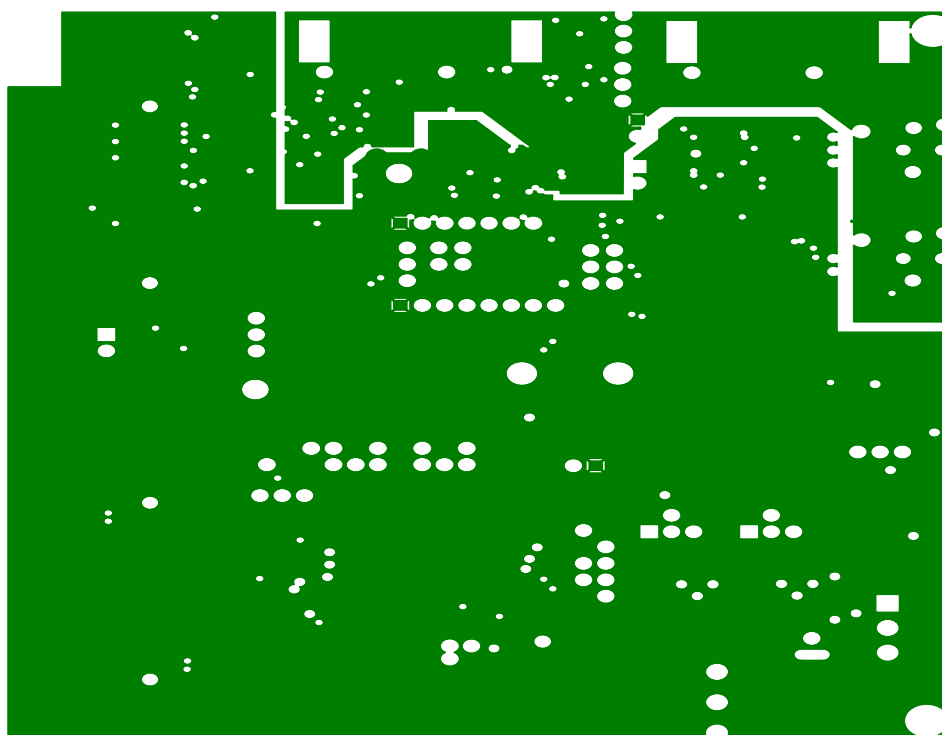

Figure 106. Si47xx-EVB Baseboard Rev 1.6—Ground Plane

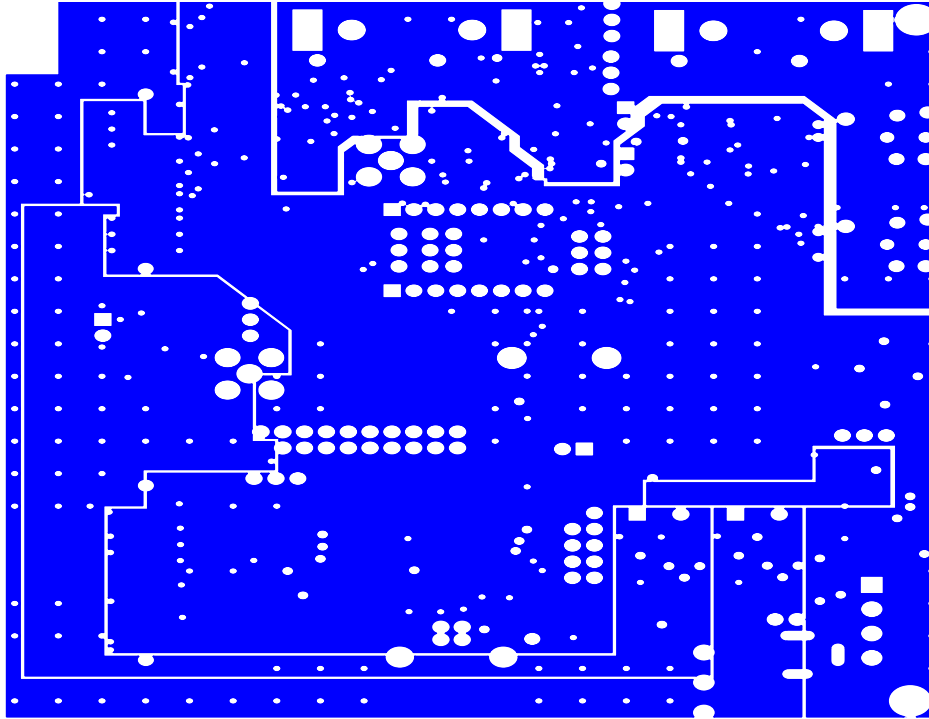

Figure 107. Si47xx-EVB Baseboard Rev 1.6—Power Plane

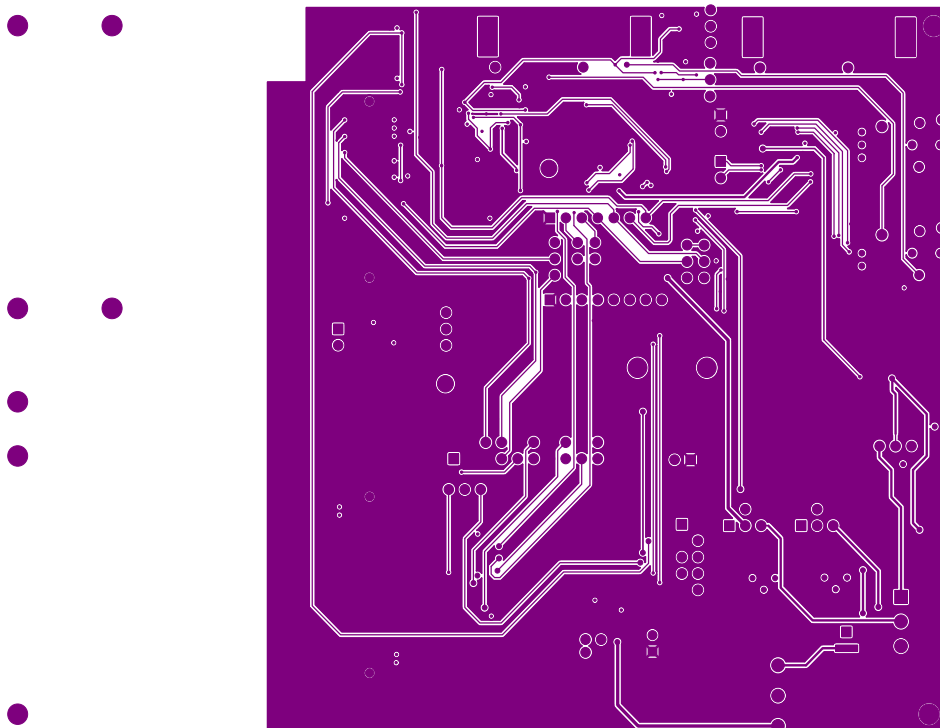

Figure 108. Si47xx-EVB Baseboard Rev 1.6—Secondary Side

Si47xx-EVB

13.2. Si471x/2x-EVB Daughtercard Rev 1.4

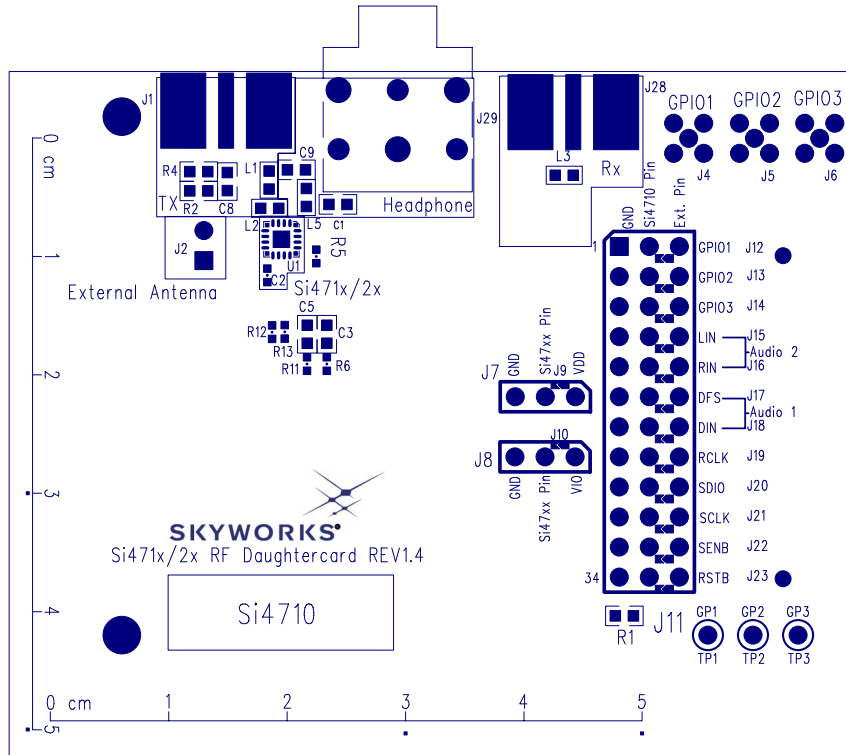

Figure 109. Si471x/2x-EVB Daughtercard (Rev 1.4)—Primary Assembly Silkscreen

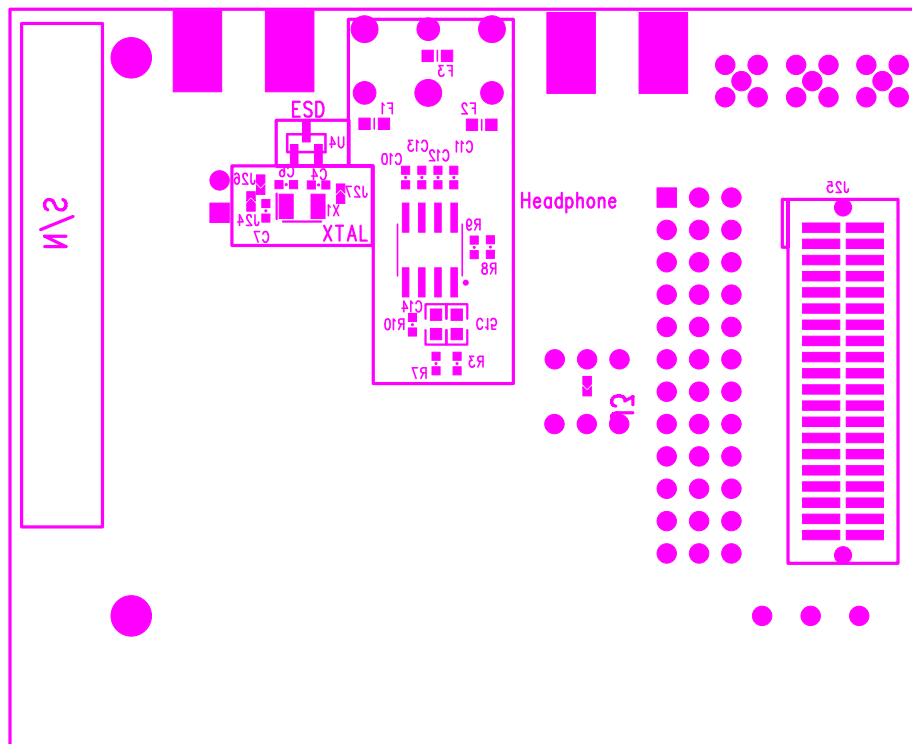

Figure 110. Si471x/2xEVB Daughtercard (Rev 1.4)—Secondary Assembly Silkscreen

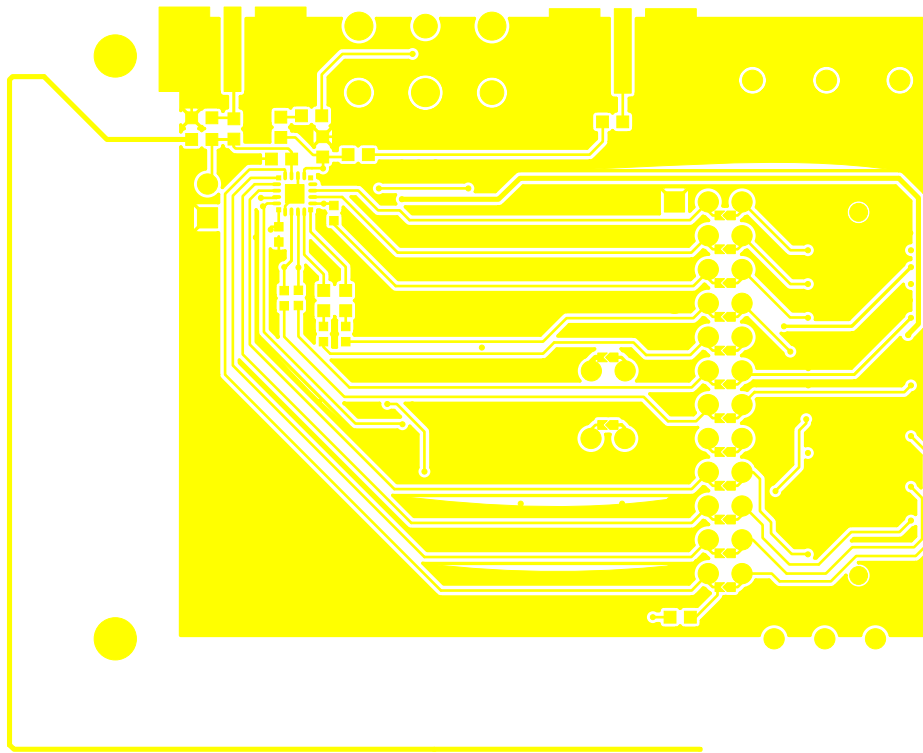

Figure 111. Si471x/2x-EVB Daughtercard (Rev 1.4)—Primary Side

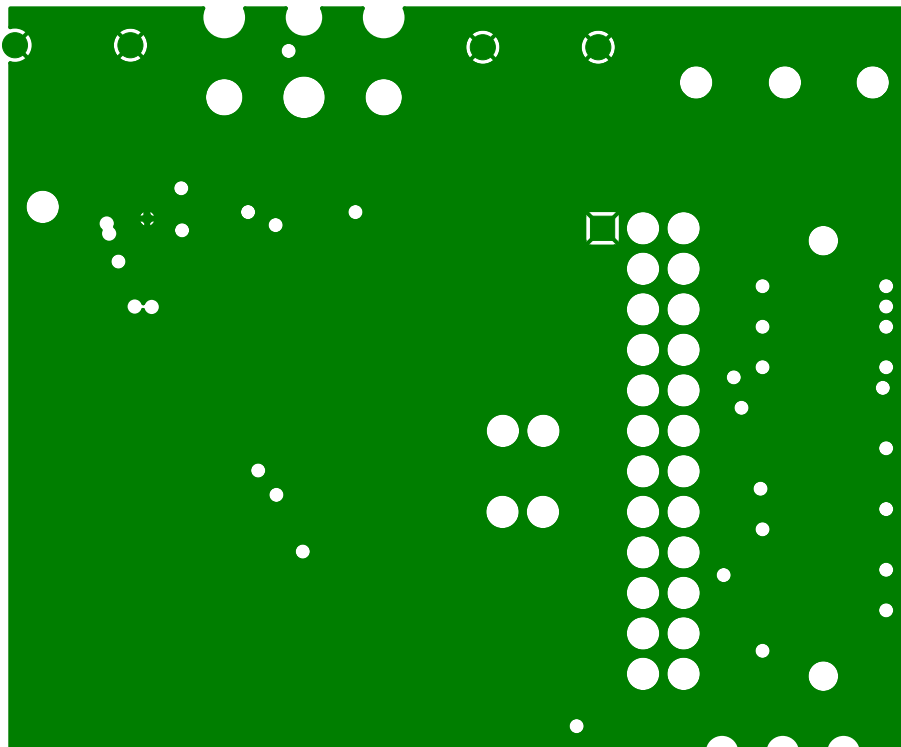

Figure 112. Si471x/2x-EVB Daughtercard (Rev 1.4)—Ground Plane

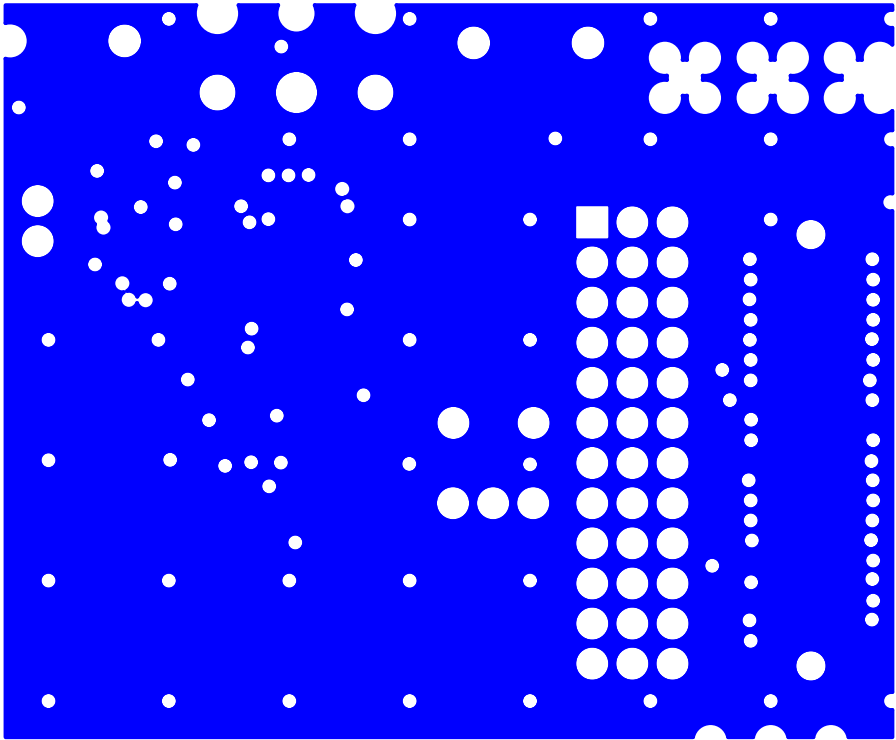

Figure 113. Si471x/2x-EVB Daughtercard (Rev 1.4)—Power Plane

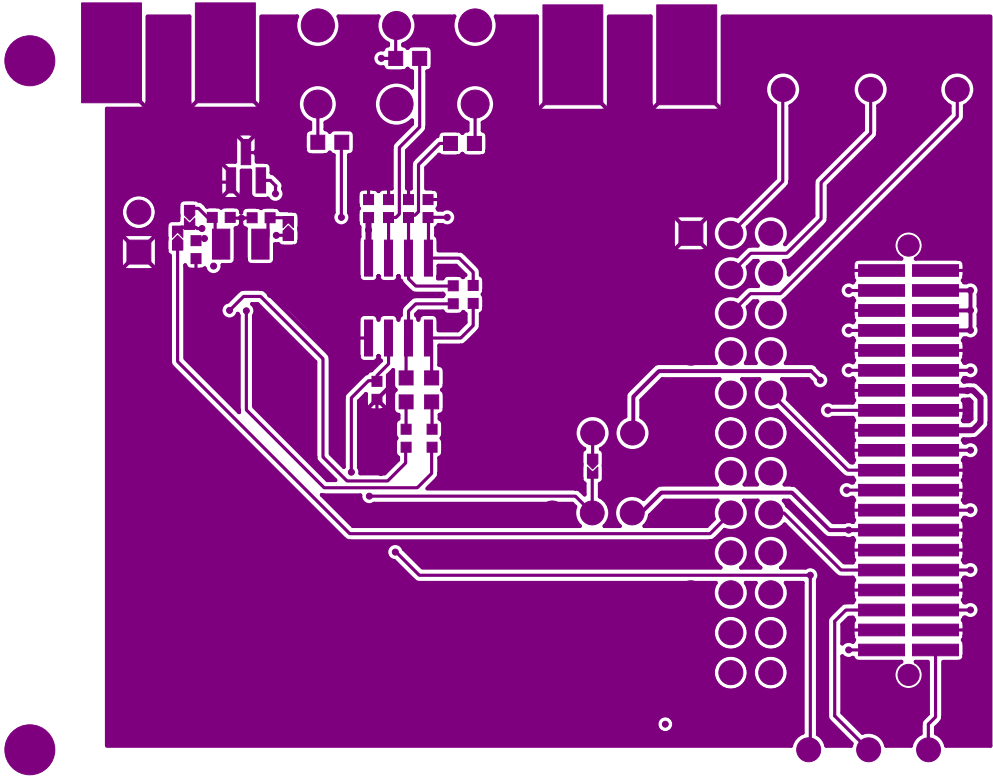

Figure 114. Si471x/2x-EVB Daughtercard (Rev 1.4)—Secondary Side

13.3. Si473x-EVB Daughtercard Rev 1.4

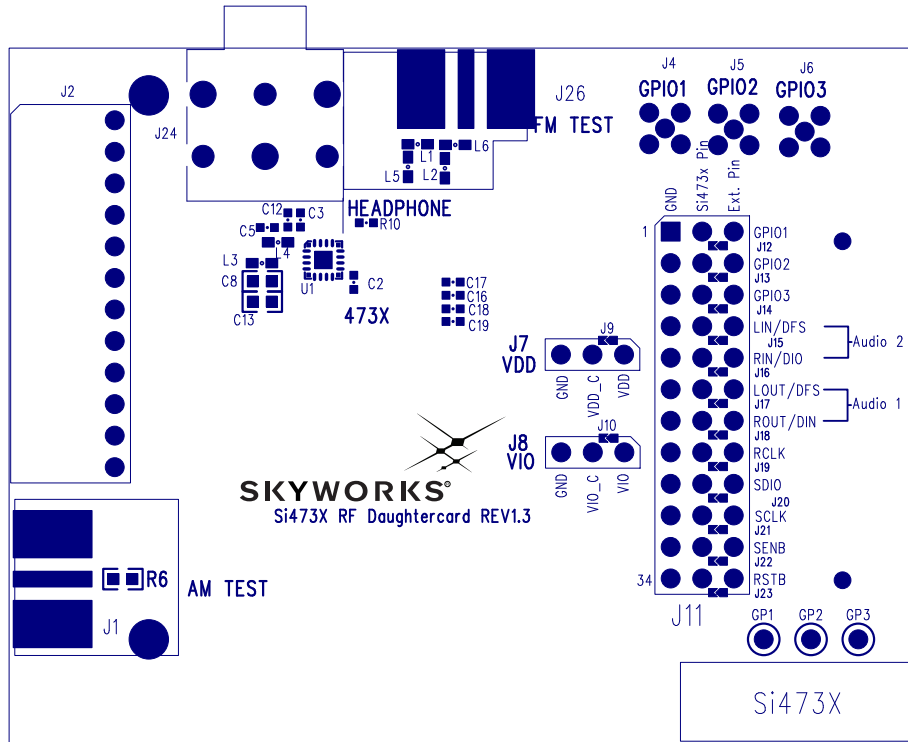

Figure 115. Si473x-EVB Daughtercard Rev 1.4 - Primary Assembly Silkscreen

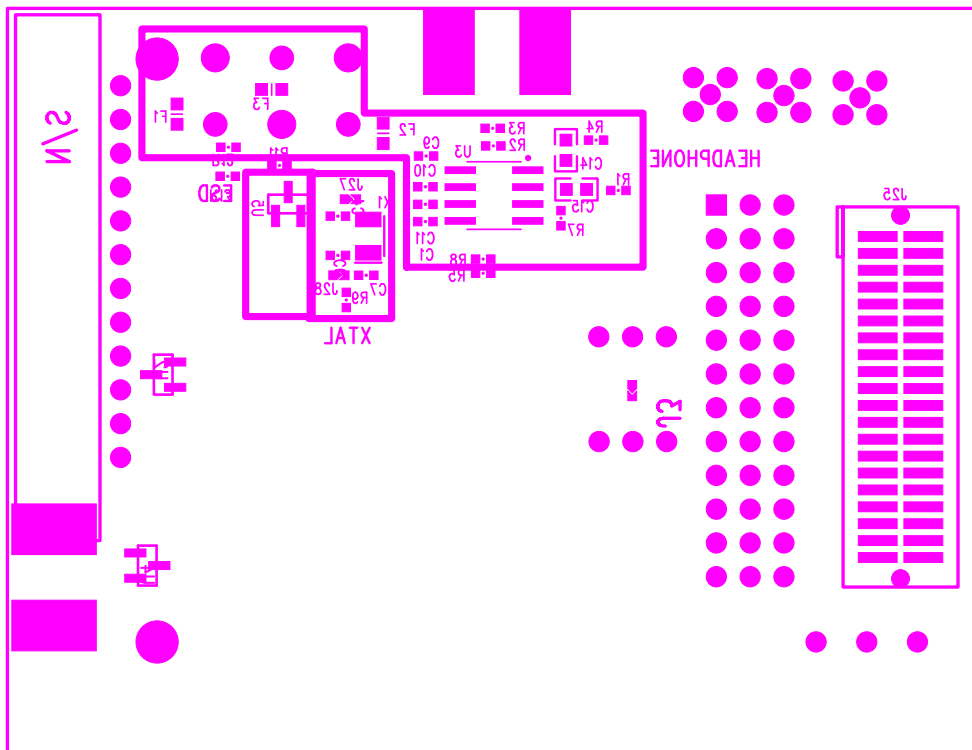

Figure 116. Si473x-EVB Daughtercard Rev 1.4 - Secondary Assembly Silkscreen

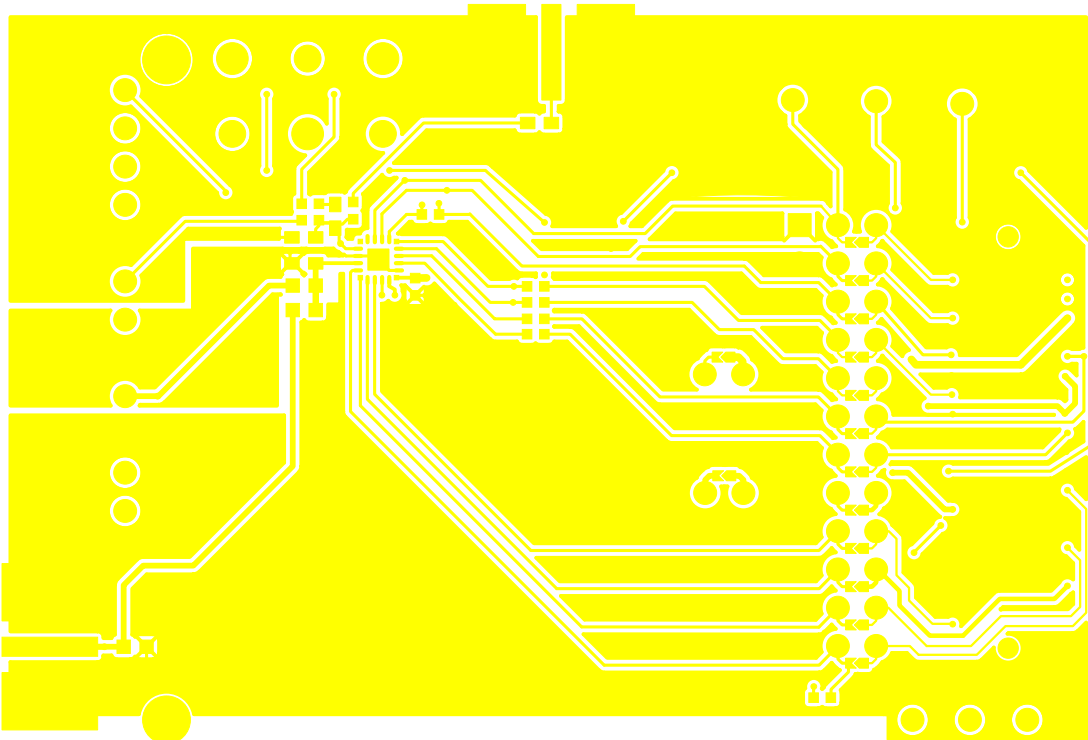

Figure 117. Si473x-EVB Daughtercard Rev 1.4—Primary Side

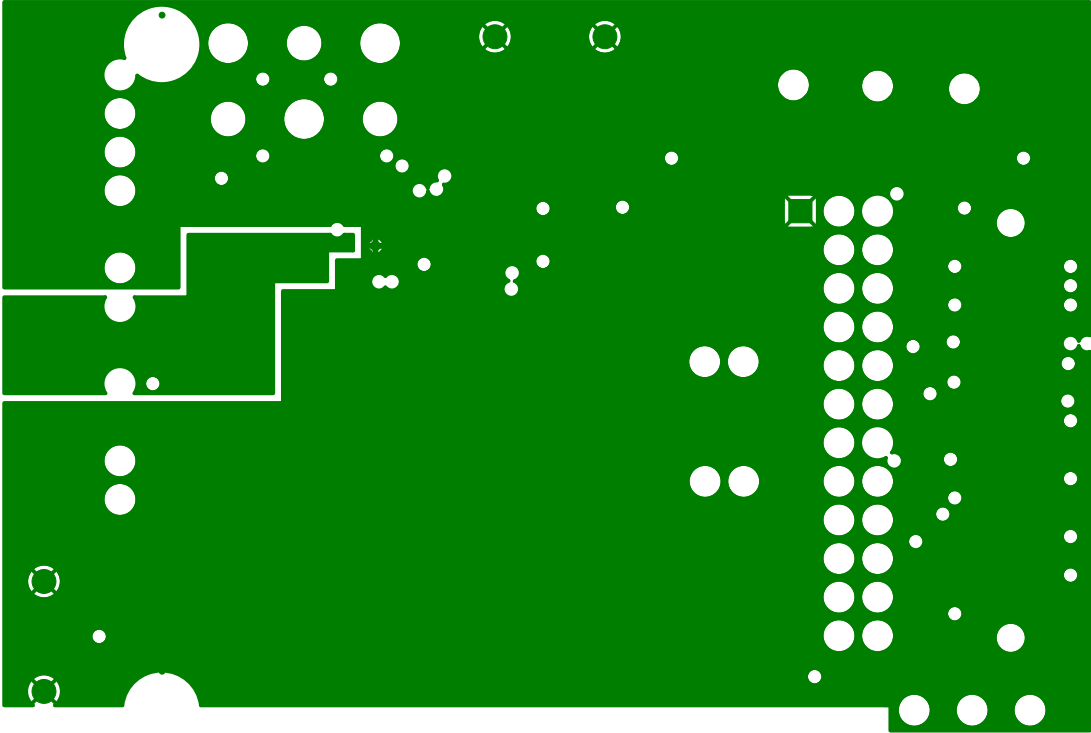

Figure 118. Si473x-EVB Daughtercard Rev 1.4—Ground Plane

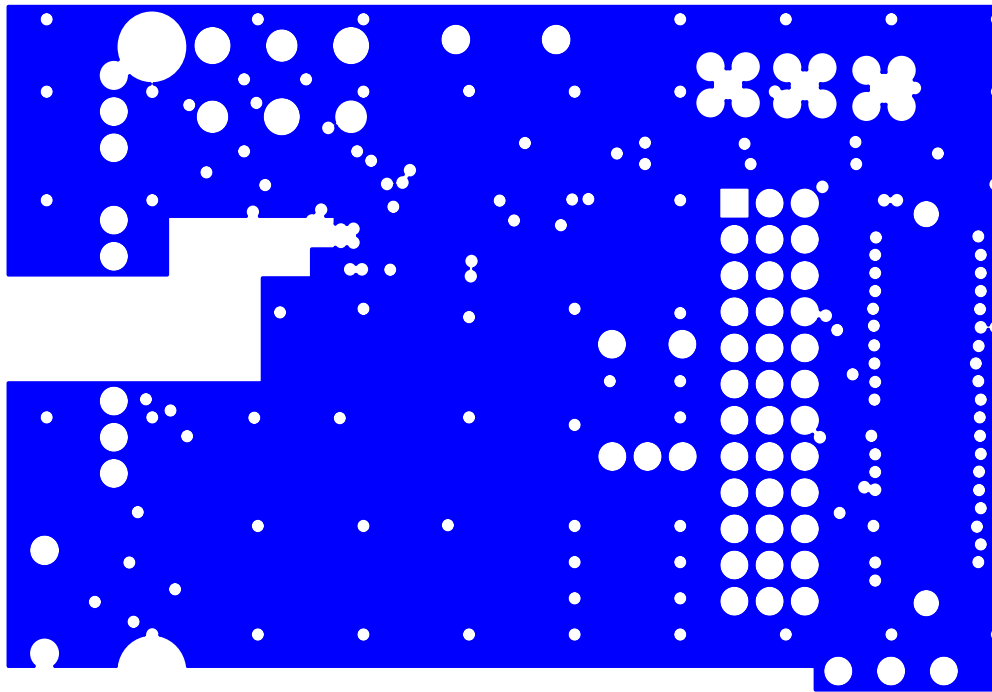

Figure 119. Si473x-EVB Daughtercard Rev 1.4—Power Plane

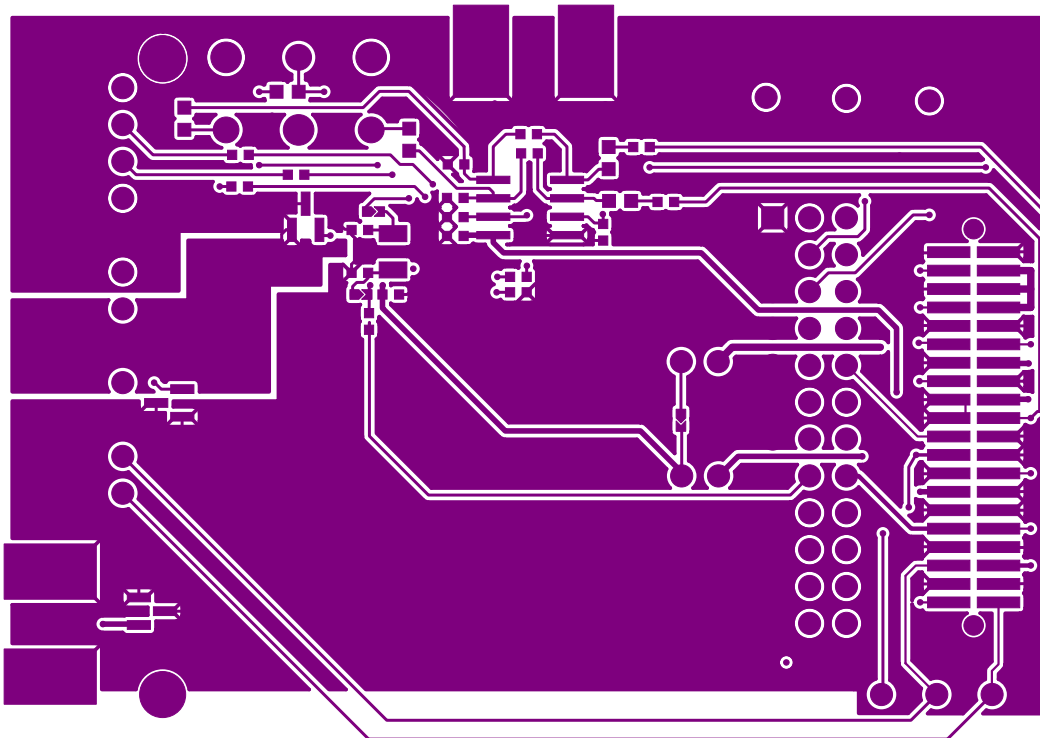

Figure 120. Si473x-EVB Daughtercard Rev 1.4—Secondary Side

Si47xx-EVB

13.4. Si474x-EVB Daughtercard Rev 1.3

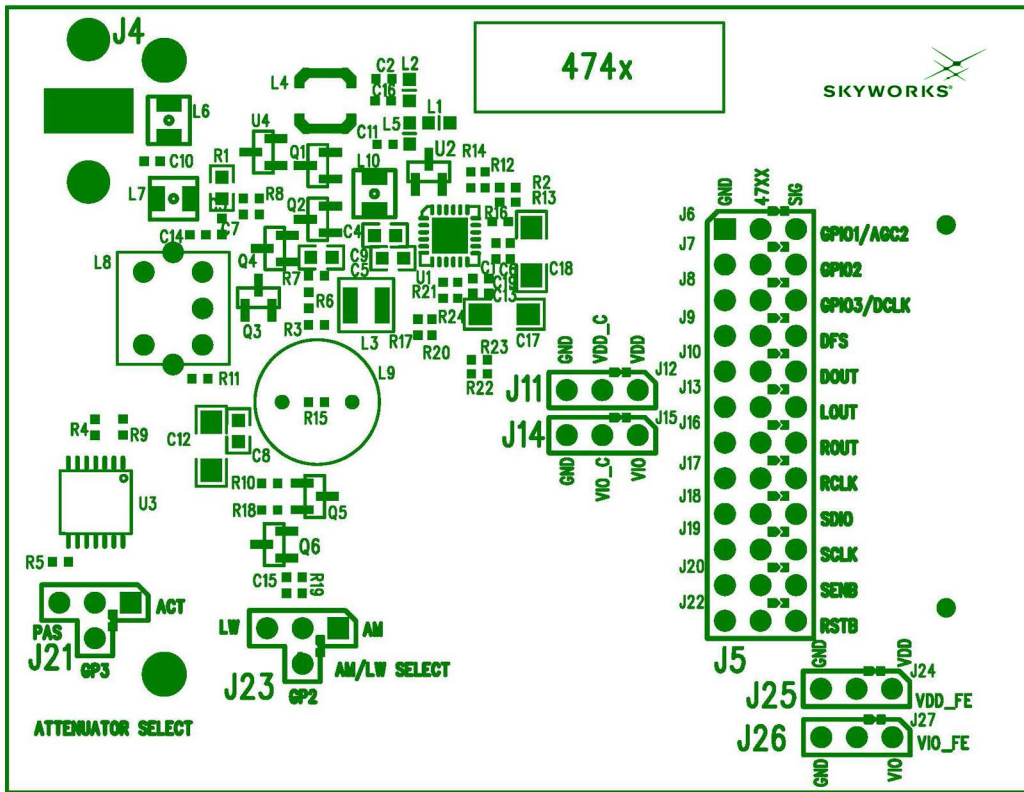

Figure 121. Si474x-EVB Daughtercard Rev 1.3—Primary Assembly Silkscreen

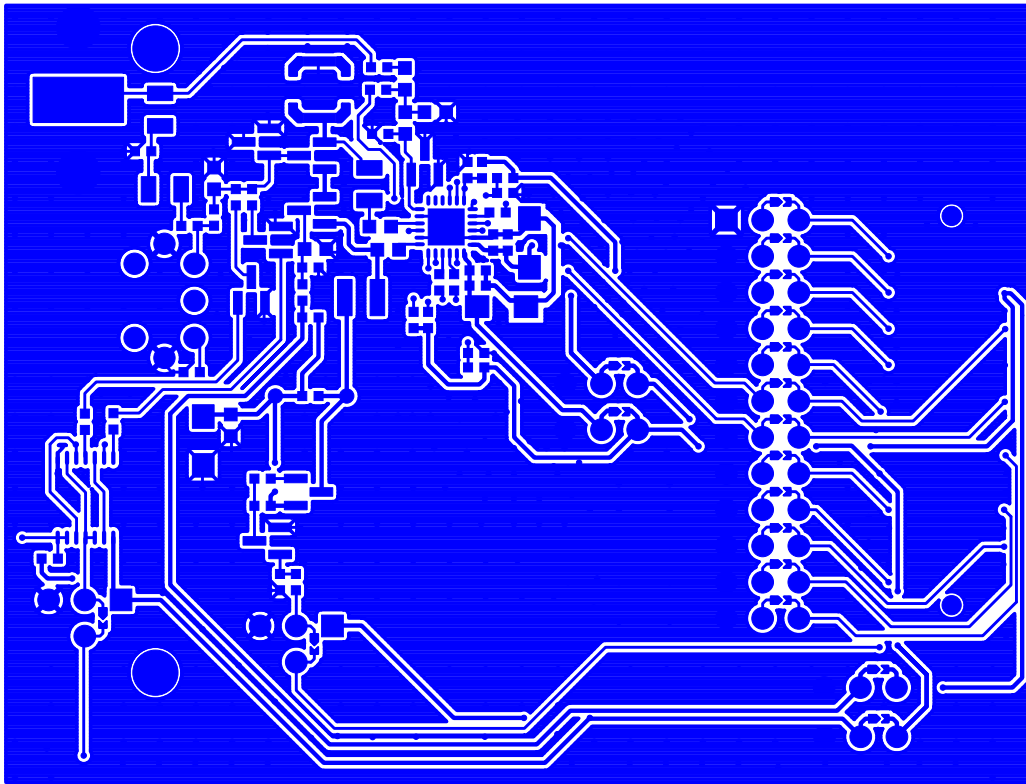

Figure 122. Si474x-EVB Daughtercard Rev 1.3—Primary Side

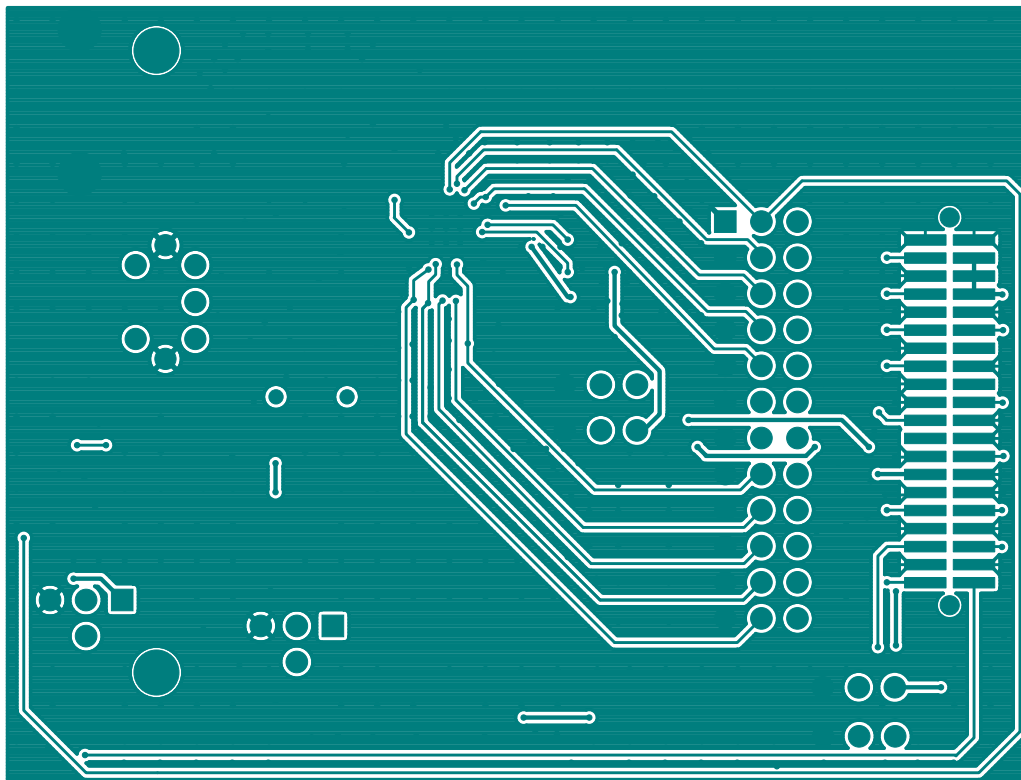

Figure 123. Si474x-EVB Daughtercard Rev 1.3—Ground Plane

Si47xx-EVB

13.5. Si4749-EVB Daughtercard Rev 1.1

Note: For Figures 124 through 129: C4, C6, R9, and R11 manually added to Si4749EVB Rev 1.0 to create Si4749 EVB Rev 1.1.

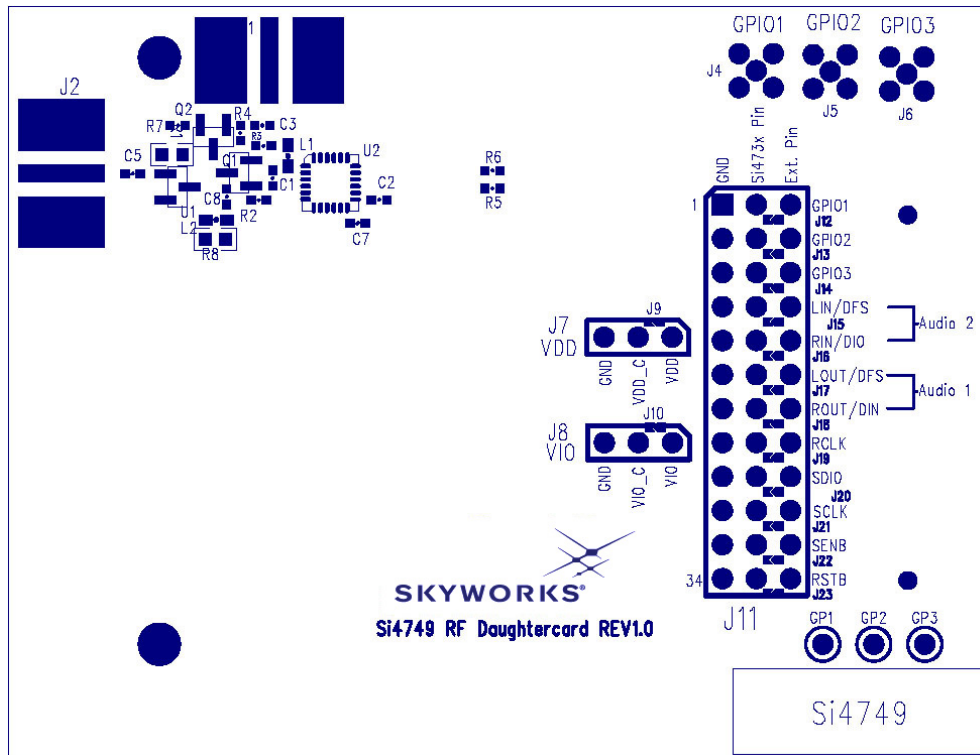

Figure 124. Si4749-EVB Daughtercard Rev 1.1—Primary Side Silkscreen

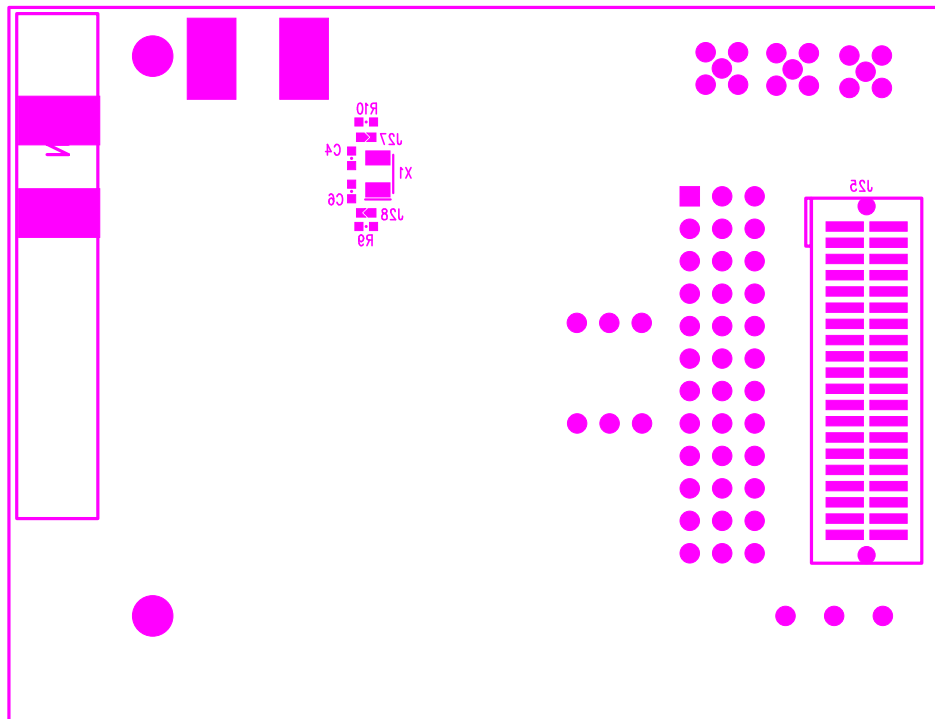

Figure 125. Si4749-EVB Daughtercard Rev 1.1—Secondary Side Silkscreen

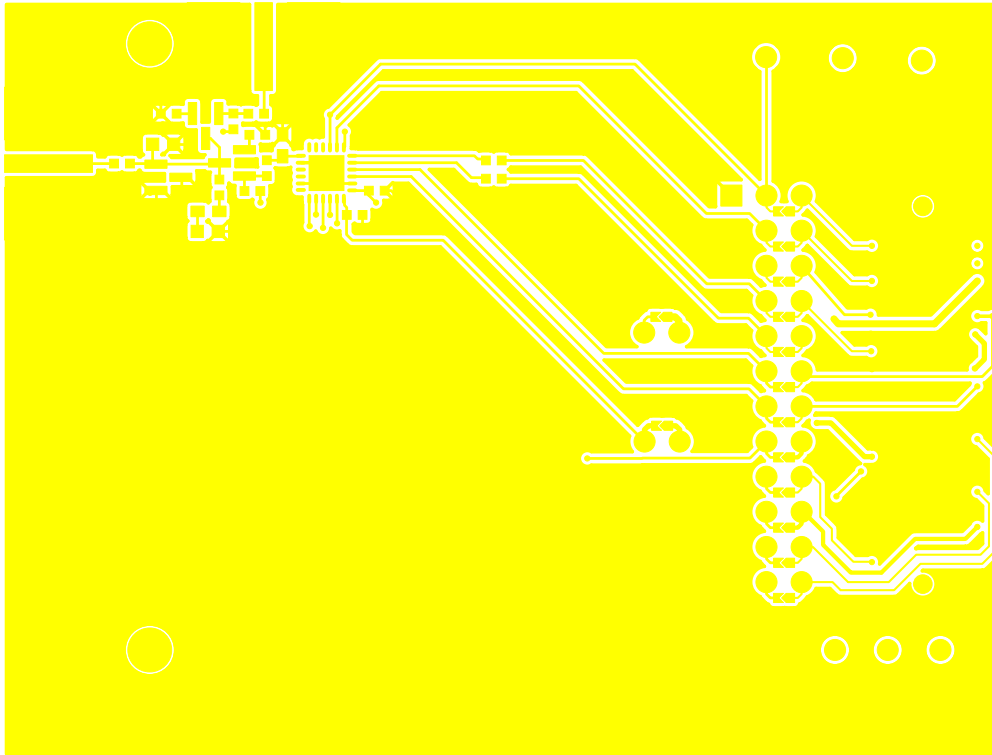

Figure 126. Si4749-EVB Daughtercard Rev 1.1—Primary Side

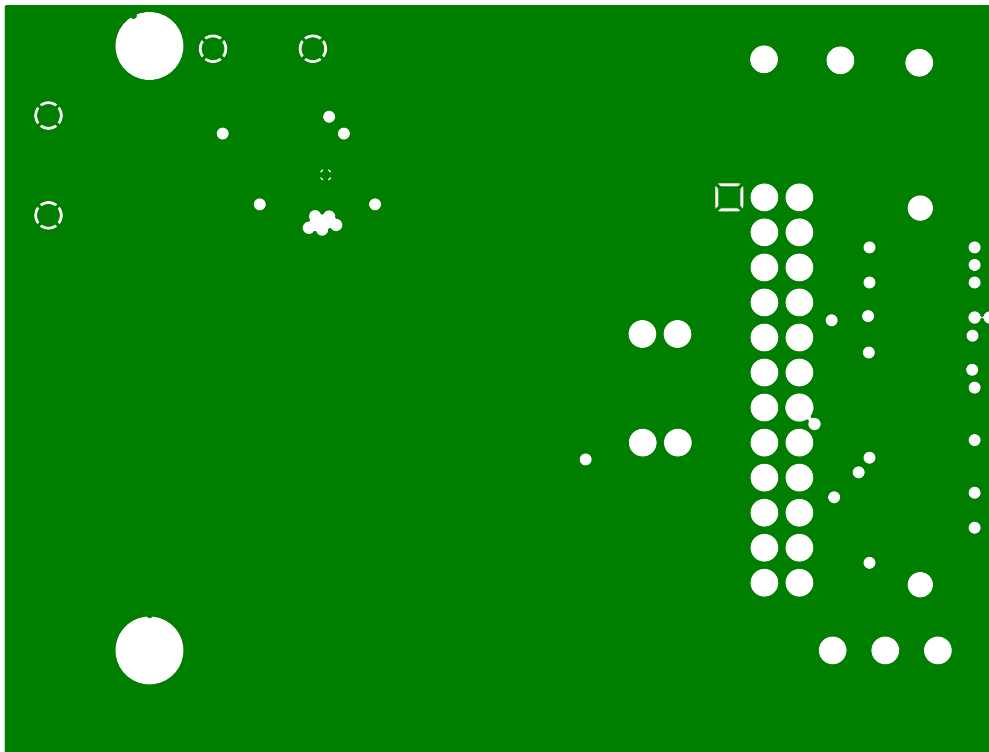

Figure 127. Si4749-EVB Daughtercard Rev 1.1—Ground Plane

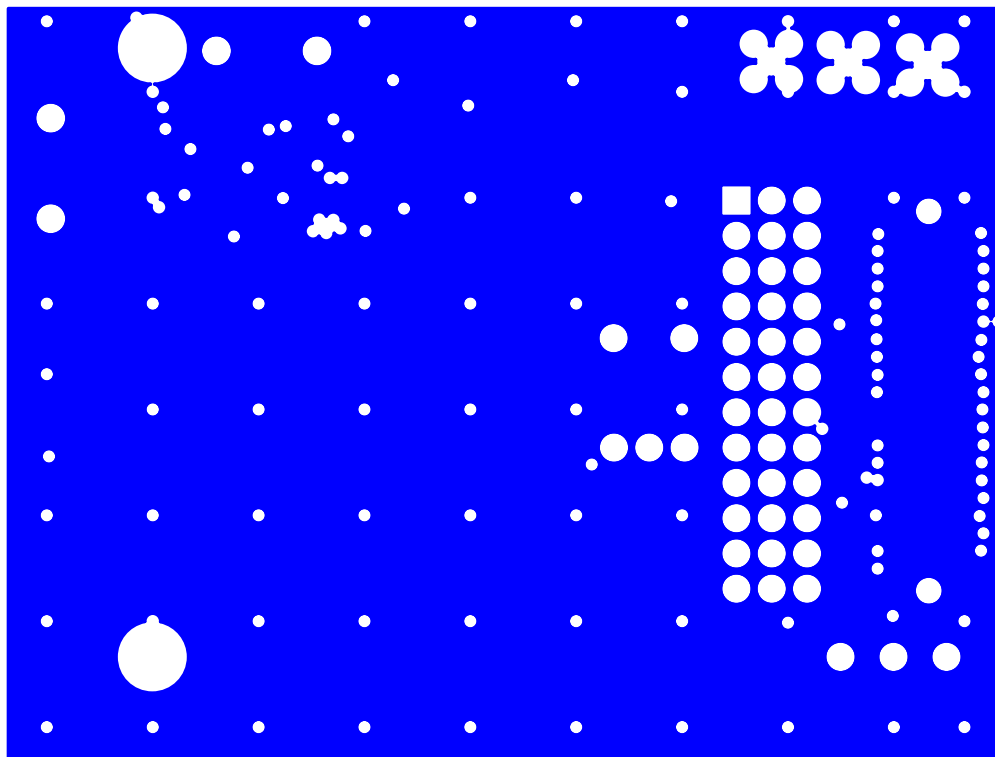

Figure 128. Si4749-EVB Daughtercard Rev 1.1—Power Plane

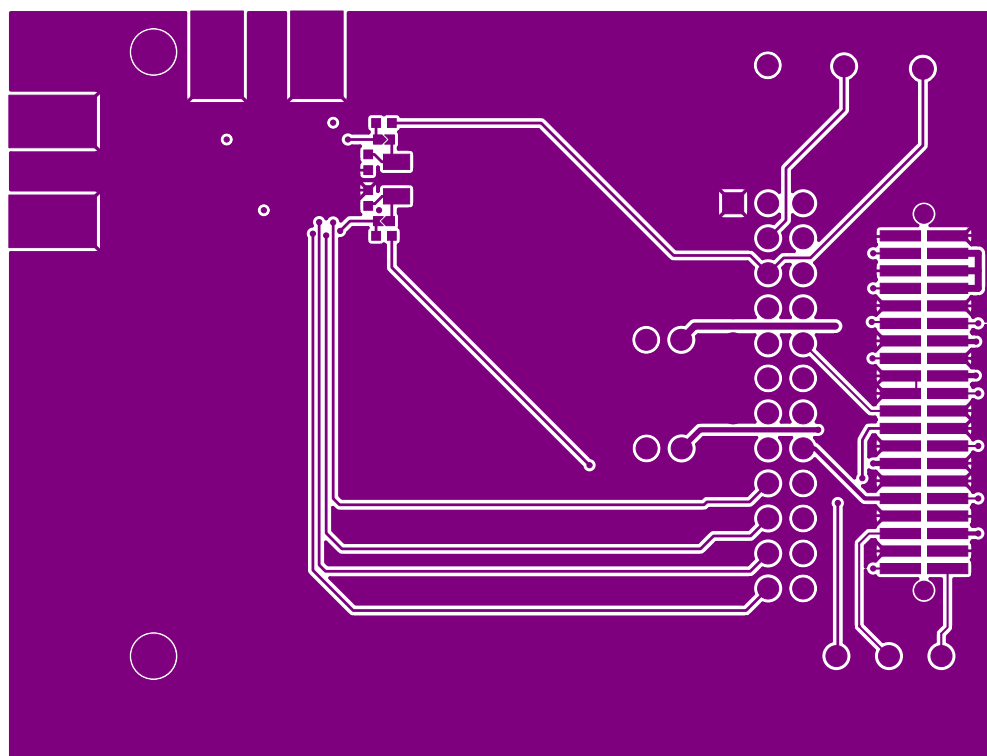

Figure 129. Si4749-EVB Daughtercard Rev 1.1—Secondary Side

13.6. Antenna Cards

13.6.1. Si473x Ferrite Antenna Card Rev 1.2

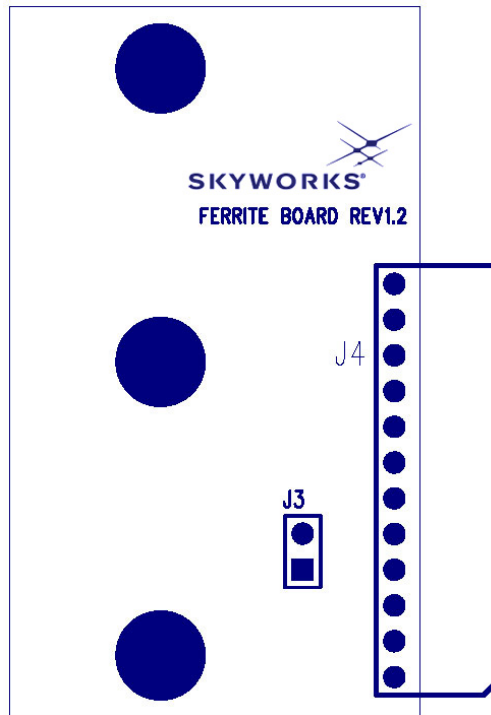

Figure 130. Si473x Ferrite Antenna Card Rev 1.2—Primary Side Silkscreen

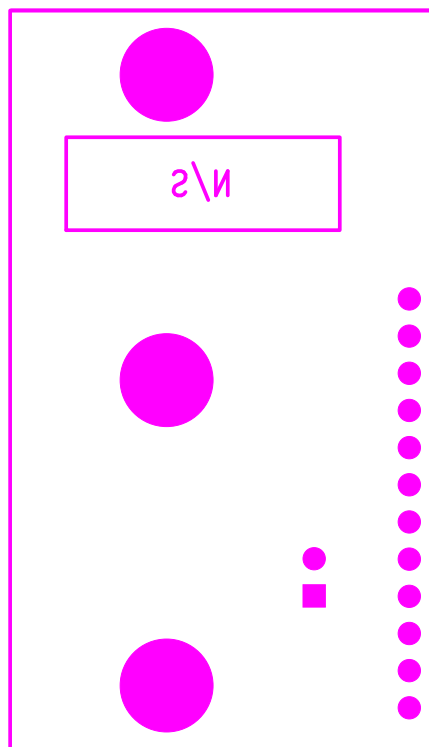

Figure 131. Si473x Ferrite Antenna Card Rev 1.2—Secondary Side Silkscreen

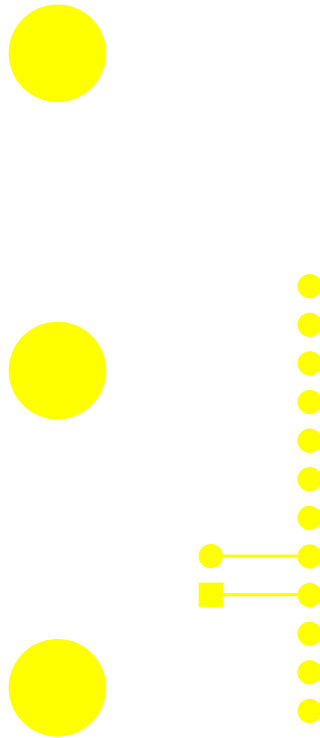

Figure 132. Si473x Ferrite Antenna Card Rev 1.2—Primary Side

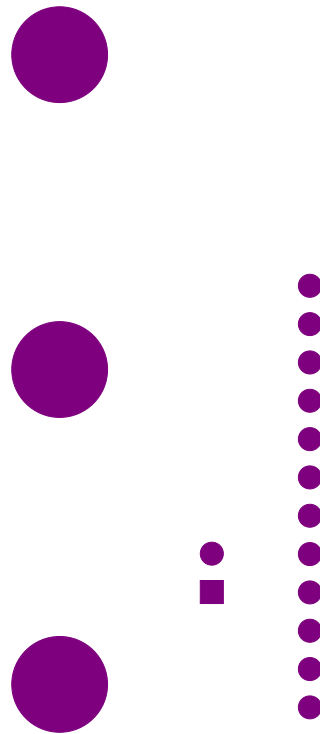

Figure 133. Si473x Ferrite Antenna Card Rev 1.2—Secondary Side

13.6.2. Si473x Air Loop Antenna Card Rev 1.2

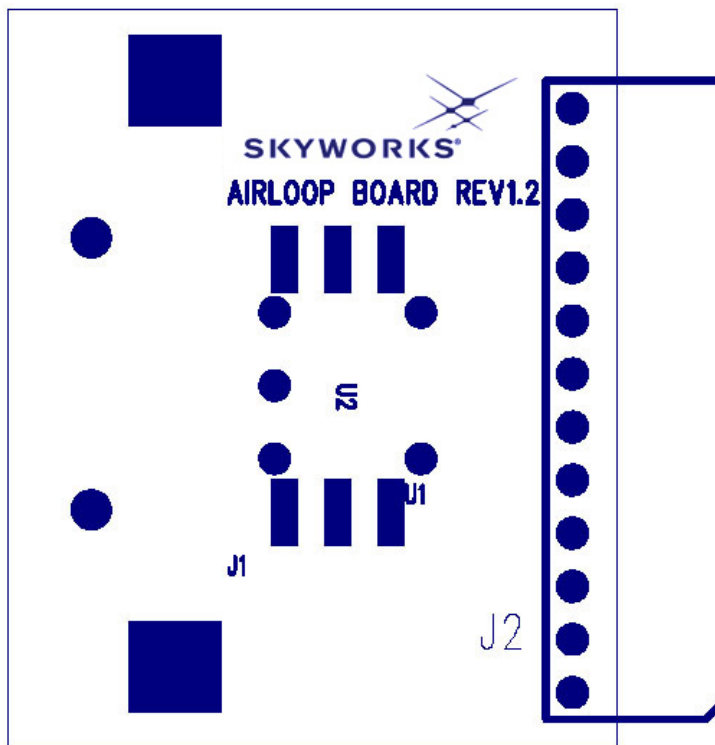

Figure 134. Si473x Air Loop Antenna Card Rev 1.2—Primary Side Silkscreen

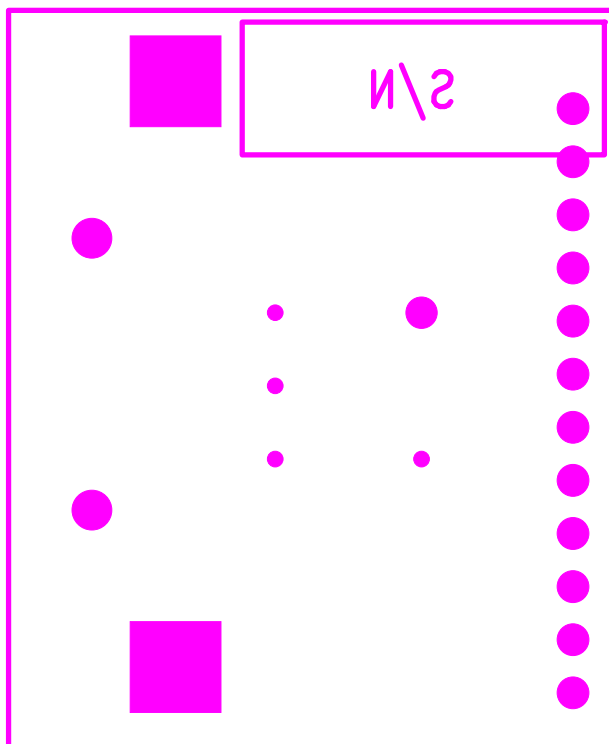

Figure 135. Air Loop Antenna Card Rev 1.2—Secondary Side Silkscreen

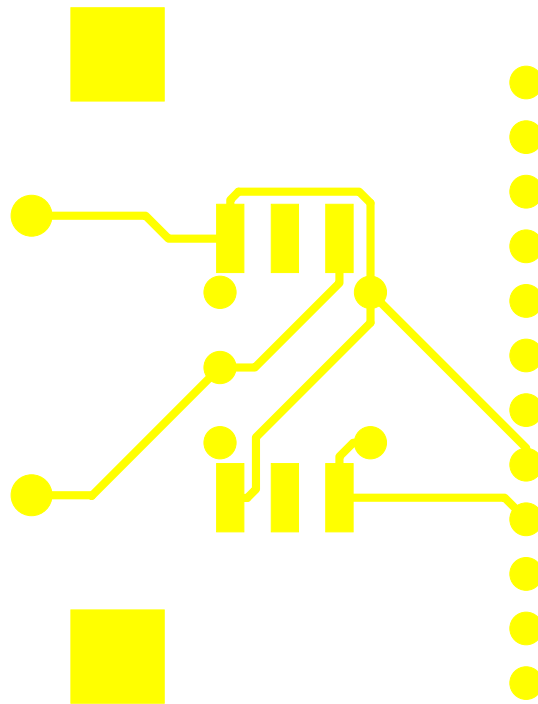

Figure 136. Si473x Air Loop Antenna Card Rev 1.2—Primary Side

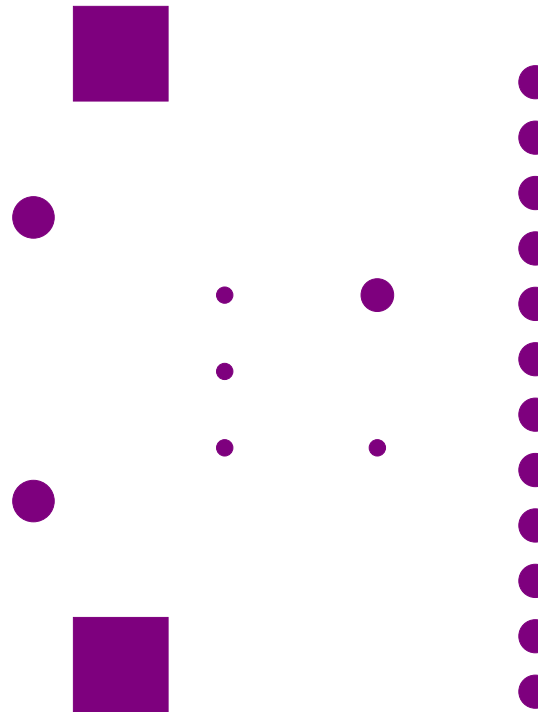

Figure 137. Si473x Air Loop Antenna Card Rev 1.2—Secondary Side

13.6.3. Si473x SW/WB Antenna Card Rev 1.3

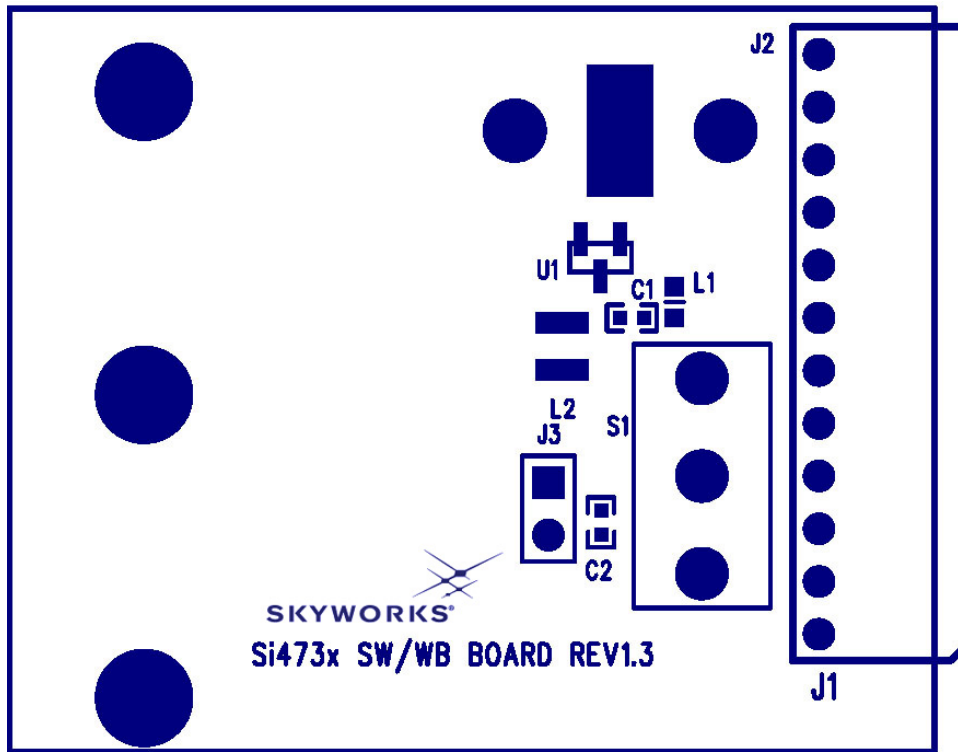

Figure 138. Si473x SW/WB Antenna Card Rev 1.3—Primary Side Silkscreen

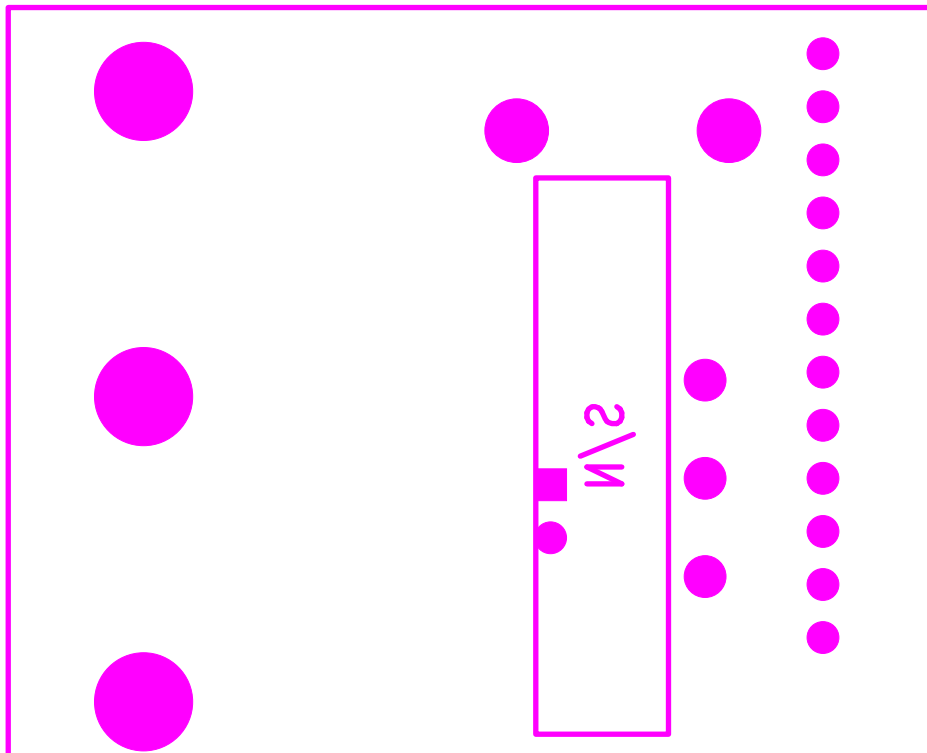

Figure 139. Si473x SW/WB Antenna Card Rev 1.3—Secondary Side Silkscreen

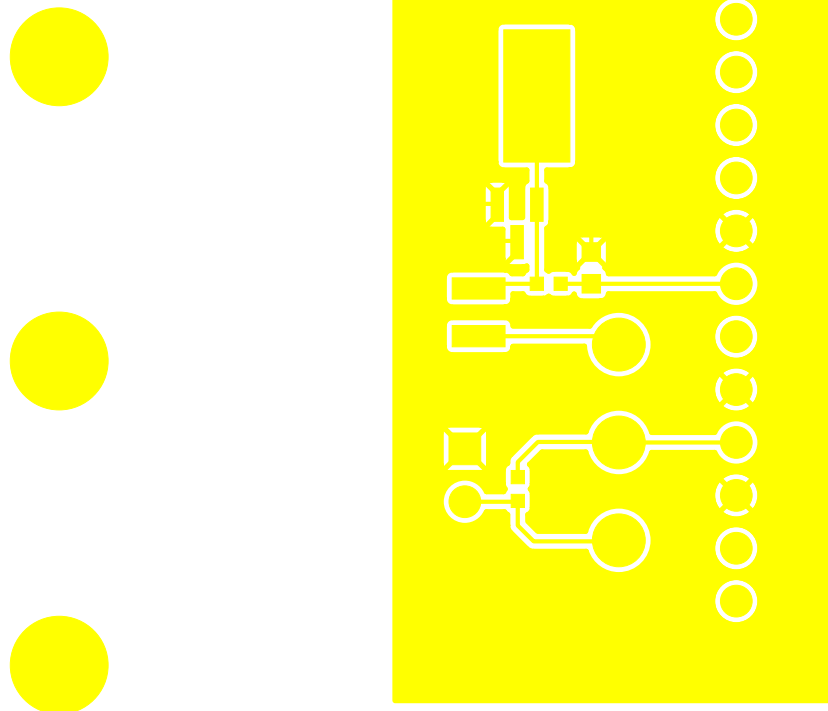

Figure 140. Si473x SW/WB Antenna Card Rev 1.3—Primary Side

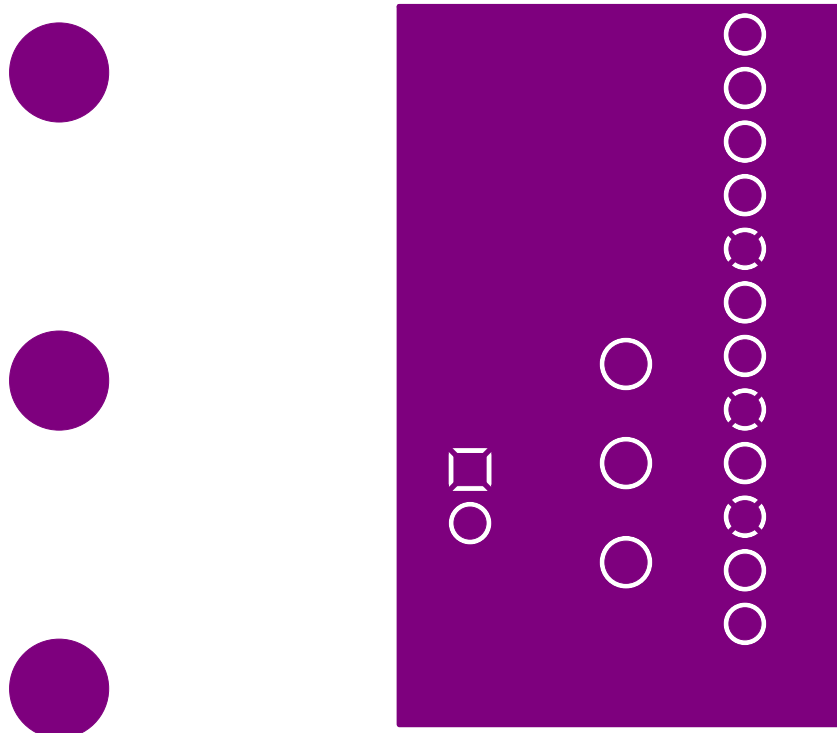

Figure 141. Si473x SW/WB Antenna Card Rev 1.3—Secondary Side

13.6.4. Si474x Antenna Dummy Card Rev 1.0

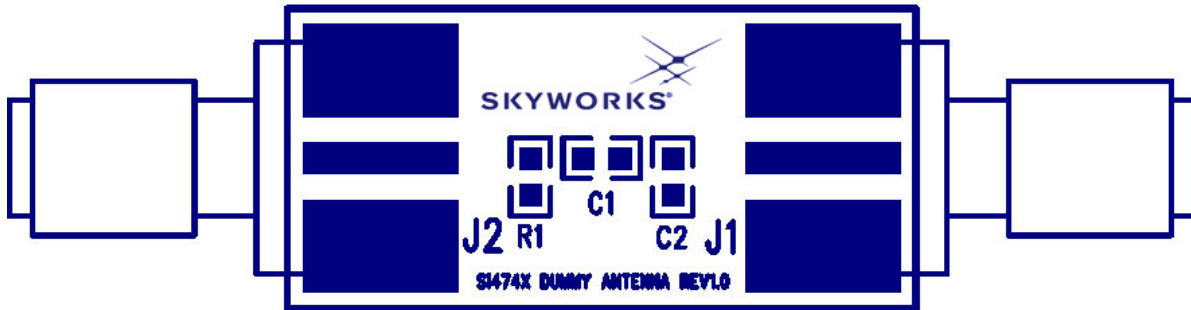

Figure 142. Si474x Antenna Dummy Card Rev 1.1—Primary Side Silkscreen

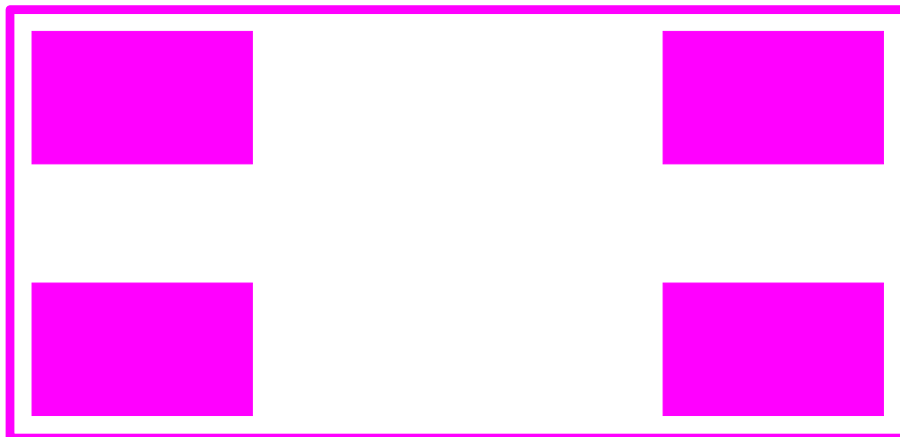

Figure 143. Si474x Antenna Dummy Card Rev 1.0—Secondary Side Silkscreen

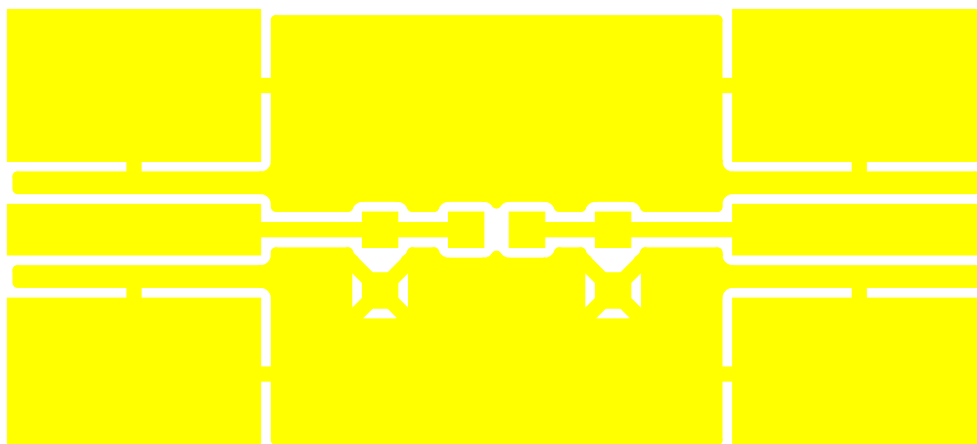

Figure 144. Si474x Antenna Dummy Card Rev 1.0—Primary Side



Figure 145. Si474x Antenna Dummy Card Rev 1.0—Secondary Side

DOCUMENTATION CHANGE LIST

Revision 0.1 to Revision 0.2

- Updated Product Family in Table 1 on page 1.
- Updated Si4740/41 Property List in Figure on page 67 and Table 15 on page 67.
- Clarified varactor recommendation with SW operation using SW/WB Antenna Card.
- Added instructions for daughtercard configurations with crystal oscillator operation.
- Added Si4707 and SAME support to Section 7.

Revision 0.2 to Revision 0.3

- Added Si4742/43 support.

Revision 0.3 to Revision 0.4

- Removed Si4706, Si4707, and Si474x NDA information from document.

Revision 0.4 to Revision 0.5

- Updated for new 4.0 GUI version
- Updated EVB BOM and Schematics to 1.6

Revision 0.5 to Revision 0.6

- Added information on State Management
- Updated figures to represent Skyworks Audio GUI version 07.2.0

Revision 0.6 to Revision 0.7

- Added Si4706/07/4x-EVB information

Revision 0.7 to Revision 0.8

- Updated for GUI version 8.2.13