

Description

The Si4732-A10 digital CMOS AM/FM/SW/LW/RDS radio receiver IC integrates the complete broadcast tuner and receiver function from antenna input to digital audio output. The device leverages the Skyworks broadcast proven digital low-IF architecture, enabling a cost-effective digital audio platform for consumer electronic applications with high TDMA noise immunity, superior radio performance, and high fidelity audio power amplification. Offering unmatched integration and PCB space savings, the Si4732-A10 requires only a few external components and less than 15 mm² of board area, excluding the antenna inputs. The Si4732-A10 AM/FM/SW/LW/RDS radio provides the space savings and low power consumption necessary for portable devices while delivering the high performance and design simplicity desired for all AM/FM/SW/LW/RDS solutions.

Leveraging Skyworks' proven and patented Si4700/01 FM tuner's digital low intermediate frequency (low-IF) receiver architecture, the Si4732-A10 delivers superior RF performance and interference rejection in the AM, FM, SW, and LW bands. The high level of integration and complete system production test simplifies design-in, increases system quality, and improves reliability and manufacturability.

Features

- Worldwide FM band support (64–108 MHz)
- Worldwide AM band support (520–1710 kHz)
- SW band support (2.3–26.1 MHz)
- LW band support (153–279 kHz)
- Excellent real-world performance with integrated AM/FM/SW/LW/RDS
- Integrated VCO
- Advanced AM/FM seek tuning
- Automatic frequency control (AFC)
- Automatic gain control (AGC)
- Digital FM stereo decoder
- Programmable de-emphasis
- Advanced Audio Processing
- Seven selectable AM channel filters
- AM/FM/SW/LW digital tuning
- EN55020 compliant
- No manual alignment necessary
- Programmable reference clock
- Adjustable soft mute control
- RDS/RBDS processor
- Digital audio out
- 2-wire and 3-wire control interface
- Integrated LDO regulator
- Wide range of ferrite loop sticks and air loop antennas supported
- SOIC package
 - RoHS compliant

Applications

- Table and portable radios
- Mini/micro systems
- CD/DVD and Blu-ray players
- Stereo boom boxes
- Modules for consumer electronics
- Clock radios
- Mini HiFi and docking stations
- Entertainment systems

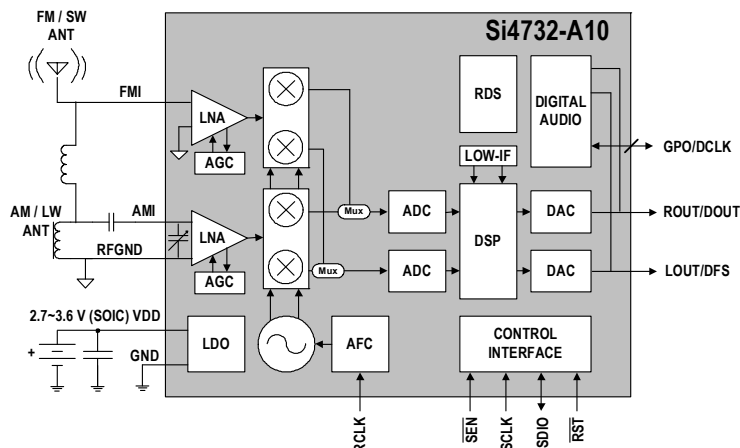

Ordering Guide

Part Number*	Description	Package Type	Operating Temperature/Voltage
Si4732-A10-GS	AM/FM/SW/LW/RDS Broadcast Radio Receiver	16L SOIC Pb-free	-20 to 85 °C 2.7 to 3.6 V
<p>*Note: Add an "(R)" at the end of the device part number to denote tape and reel option. The devices will typically operate at 25 °C with degraded specifications for V_{DD} voltage ramped down to 2.0 V.</p>			

Pin Assignments

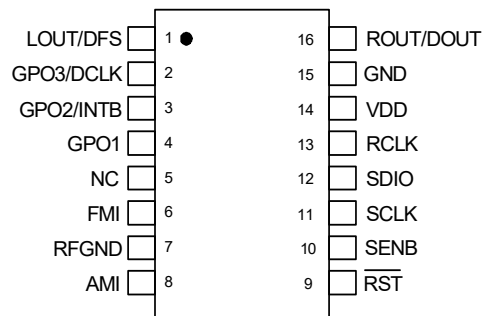

16L SOIC Package Information

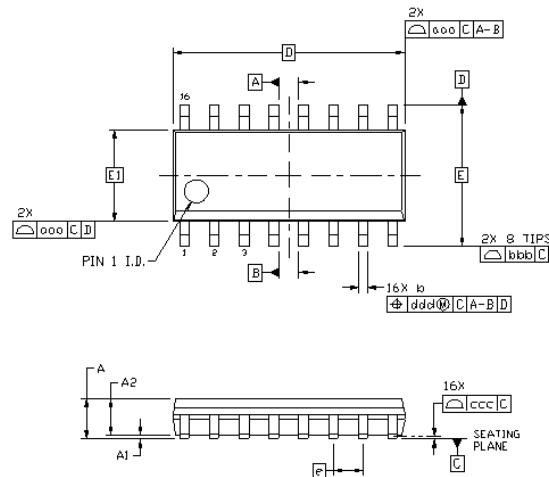

Table 1. Package Dimensions

Dimension	Min	Max	Dimension	Min	Max
A	—	1.75	L	0.40	1.27
A1	0.10	0.25	L2	0.25 BSC	
A2	1.25	—	h	0.25	0.50
b	0.31	0.51	theta	0°	8°
c	0.17	0.25	aaa	0.10	
D	9.90 BSC		bbb	0.20	
E	6.00 BSC		ccc	0.10	
E1	3.90 BSC		ddd	0.25	
e	1.27 BSC				

Notes:

1. All dimensions shown are in millimeters (mm) unless otherwise noted.
2. Dimensioning and Tolerancing per ANSI Y14.5M-1994.
3. This drawing conforms to the JEDEC Solid State Outline MS-012, Variation AC.
4. Recommended card reflow profile is per the JEDEC/IPC J-STD-020 specification for Small Body Components.