

Si5356 EVALUATION BOARD USER'S GUIDE

Description

The Si5356 evaluation board (EVB) is used for evaluating the Si5356 I²C programmable, any frequency 1–200 MHz, quad frequency 8-output clock generator.

EVB Features

- Fully powered from a single USB port
- On-board 25 MHz XTAL allows standalone asynchronous operation
- GUI programmable V_{DD} supply allows device to operate from 3.3 V, 2.5 V, or 1.8 V (core)
- GUI programmable V_{DDO} supplies allows each of the four banks of outputs to have its own supply voltage selectable from 3.3 V, 2.5 V, and 1.8 V
- GUI controlled voltage, current, and power measurements of V_{DD} and all four V_{DDO} supplies.
- Voltage supply jumpers allows easy access for use of external supplies or current measurements.

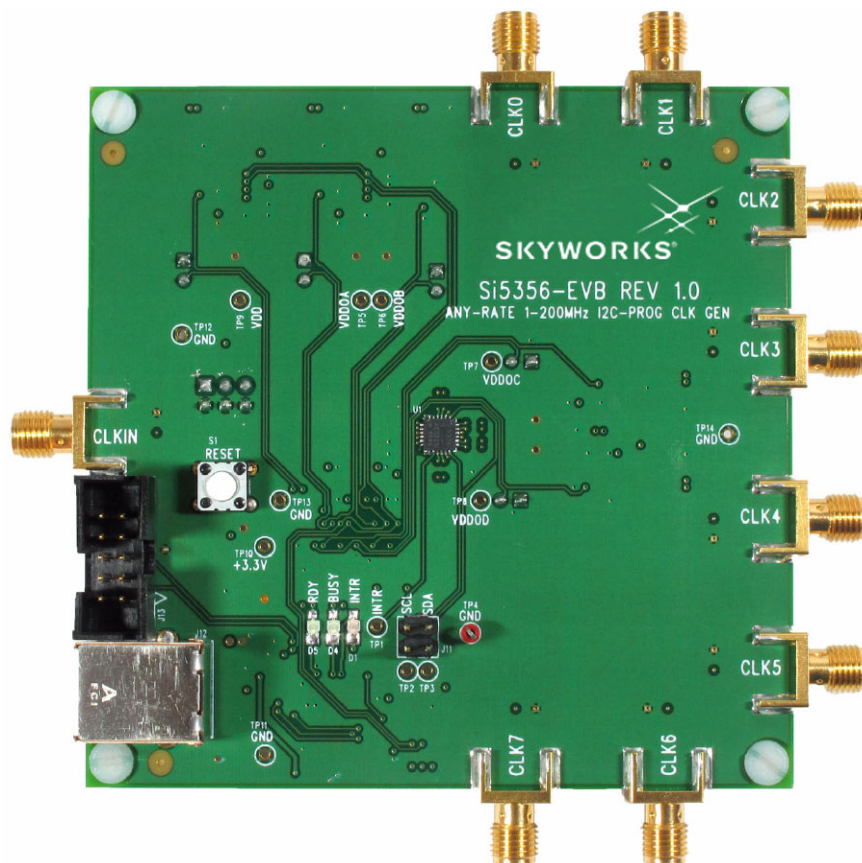

Figure 1. Si5356 Evaluation Board

1. Quick Start

Perform the following steps to get started quickly:

1. Install the latest [Skyworks ClockBuilder Pro \(CBPro\) software](#).
2. Connect a USB cable from the EVB to the PC where the software was installed.
3. Leave the jumpers as installed from the factory and launch the newly installed ClockBuilder Pro.
4. Select “Open Default Plan” under the Evaluation Board Detected heading, and click “Yes” when prompted to “Write Design to EVB”. This will write a preset configuration to the Si5356 device on the evaluation board. From this point on, the Si5356 can be configured through the CBPro Configuration Wizard, and the EVB can be controlled through the CBPro EVB GUI.



Figure 2. Select Open Default Plan

2. Functional Description

A function block diagram of the EVB is shown in Figure 3. The MCU performs the USB to I²C conversion, controls the voltage regulators, monitors the INTR pin, and controls the three status LEDs. There are five programmable voltage regulators (VDD, VDDOA, VDDOB, VDDOC, VDDOD), which supply power to the Si5356 device. VDD and VDDO jumpers allow the option of powering the device from external supplies or as a convenient point for measuring current. I²C jumpers allow disconnecting the Si5356 from the I²C bus to allow external control from another I²C master.

The Si5356 EVB is shipped with an on-board 25 MHz XTAL to allow stand-alone asynchronous operation. The Si5356 can be synchronized to an external reference using the CLKIN input and selecting the external reference using the ClockBuilder Pro software.

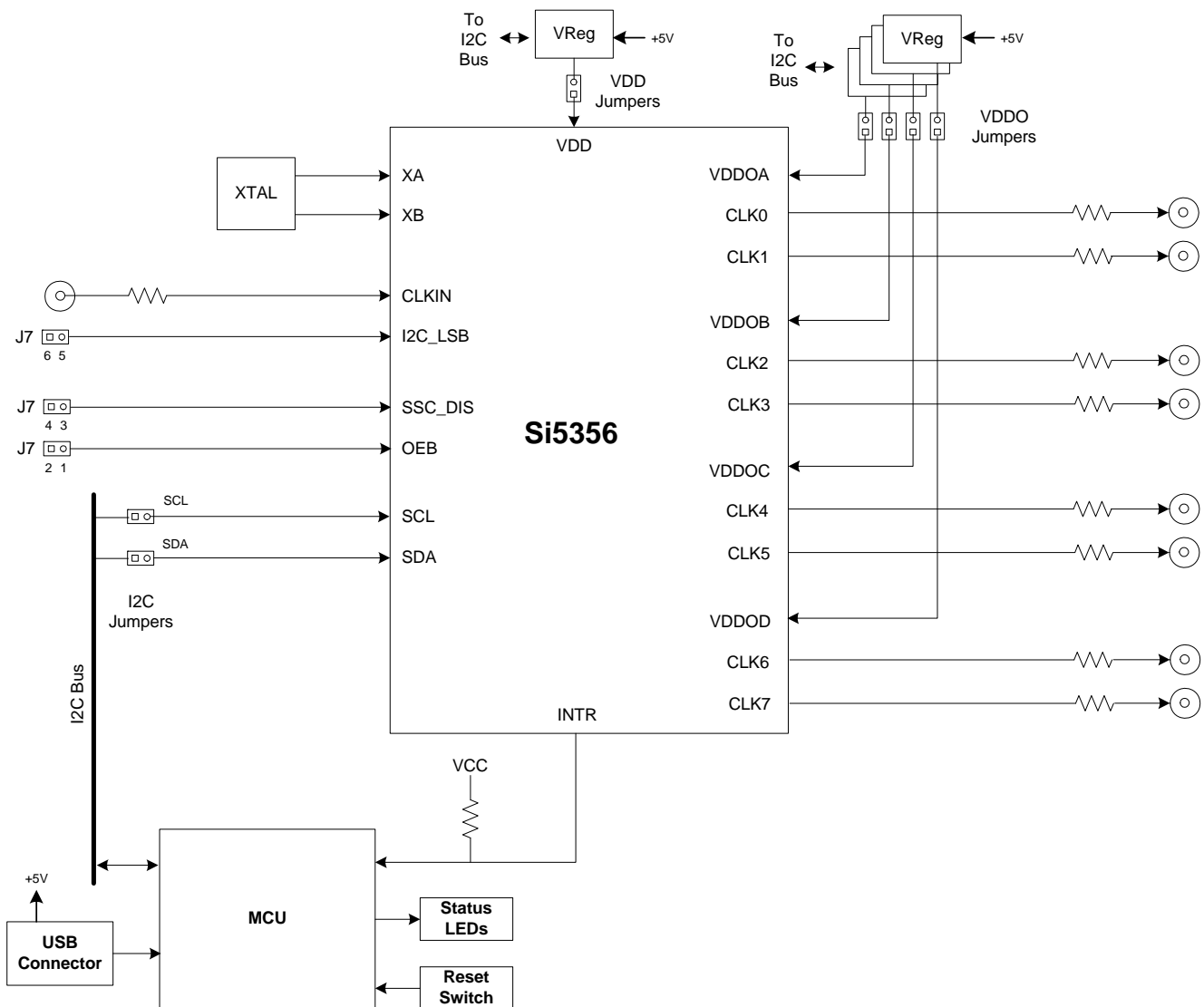

Figure 3. EVB Functional Block Diagram

2.1. Status LEDs

There are three status LEDs on the EVB:

- **RDY** (Green) indicates that the EVB is operating as normal. This LED should always be on.
- **BUSY** (Green) lights when there is active communication between the PC, the MCU, and the Si5356.
- **INTR** (Red) indicates the MCU has detected that the interrupt pin of the Si5356 device is enabled. The most probable cause for an interrupt is because the Si5356 has lost its input signal or the PLL has lost lock. The “Status Registers” tab of the EVB GUI will identify the event that caused the interrupt to happen.

2.2. Inputs

The Si5356 EVB provides two reference options - using the on-board XTAL or an external reference.

Note: Si5356-EVB Rev 1.0 does not support synchronous operation using the CLKIN input. This feature will be supported in future revisions.

2.2.1. External Input reference

An SMA connector (CLKIN) is provided to receive an external single-ended CMOS signal. This input is dc-coupled to the device. The signal should have a minimum amount of dc bias to ensure that it never swings below ground level.

2.2.2. Onboard XTAL

The onboard 25 MHz allows the Si5356 EVB to generate asynchronous clocks. To use this option, select the XTAL input from the Si5356 “ClockBuilder Pro” software.

2.3. Outputs (CLK0-CLK7)

Each of the eight output clocks can be accessed using SMA connectors. The outputs are dc-coupled (no in-line dc blocking capacitors between the output pin and the SMA connector).

2.4. Control Pins

Header J7 located on the backside of the Si5356 EVB allows setting three Si5356 control pins: SSC_DIS, I2C_LSB, and OEB.

2.4.1. SSC_DIS

This pin allows disabling of the spread spectrum feature on the output clocks. Spread spectrum is disabled when the jumper is installed.

2.4.2. I2C_LSB

This pin is the least significant bit of the Si5356 I²C address allowing up to two Si5356 devices to occupy the same I²C bus. I²C address of the Si5356 = 0x70 when the jumper is installed. I²C address of the Si5356 = 0x71 when the jumper is not installed.

2.4.3. OEB

This pin allows disabling all output clocks. All outputs are enabled when the jumper is installed.

2.5. Voltage Regulators

The Si5356 EVB has five built-in programmable voltage regulators to allow setting of the VDD supply (to 3.3 V, 2.5 V, and 1.8 V) and the four VDDO supplies (to 3.3 V, 2.5 V, and 1.8 V). The voltage level on each of these supplies can be set independently through the Regulators tab in the EVB GUI.

2.6. Reset Switch

A reset switch is provided to reset communication between the PC and Si5356 EVB.

3. Si5356-EVB Schematics

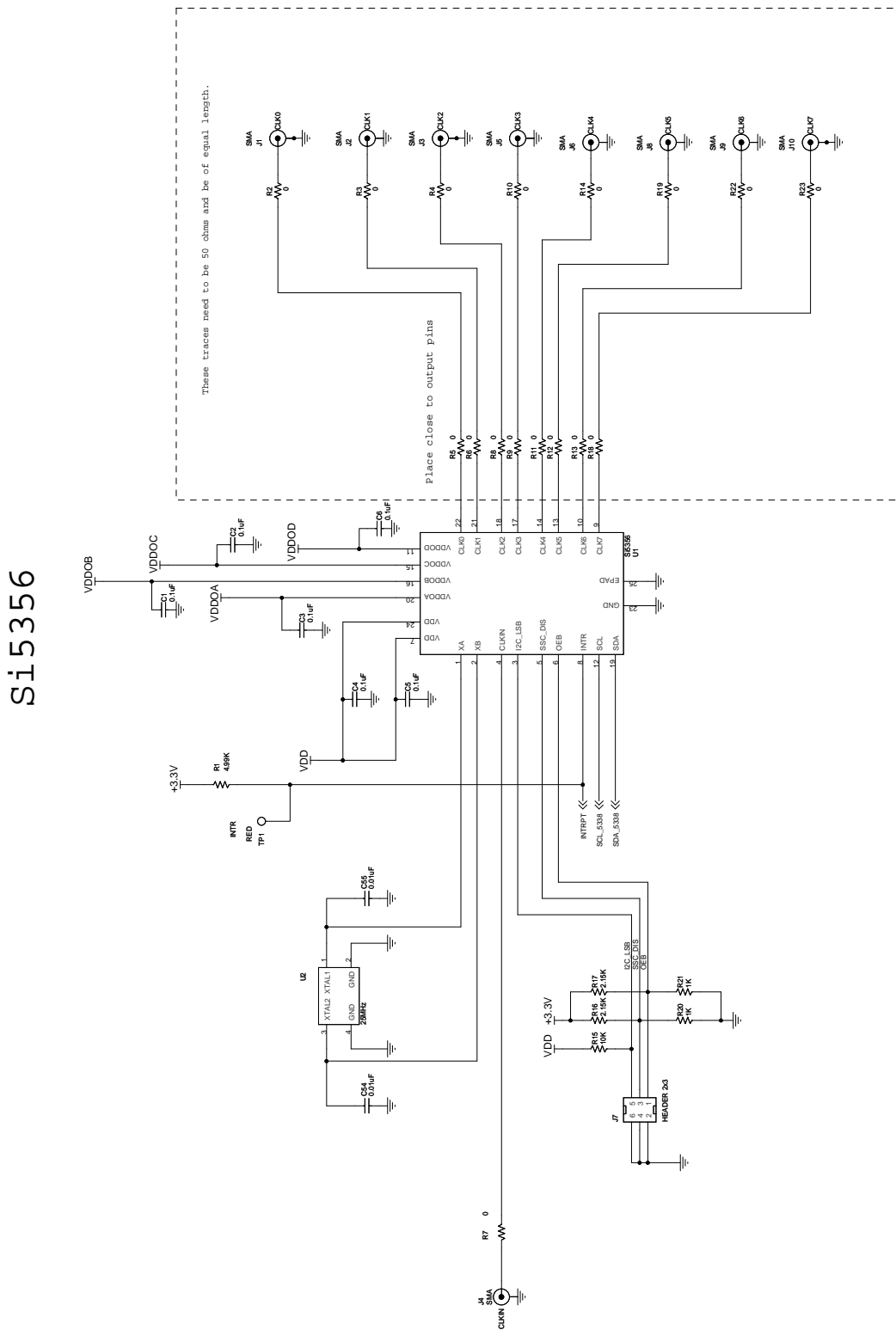

Figure 4. Si5356-EVB Schematic

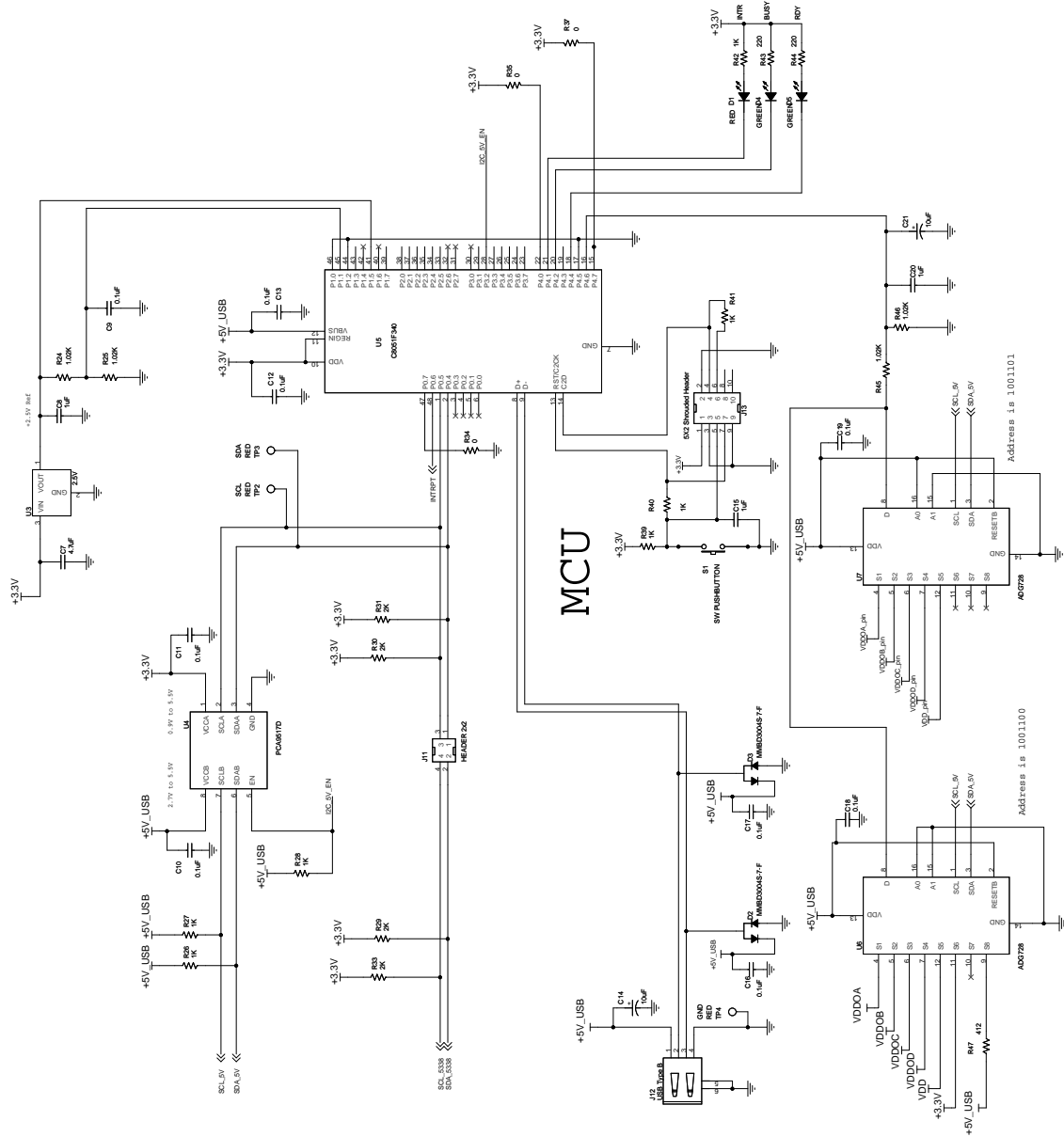
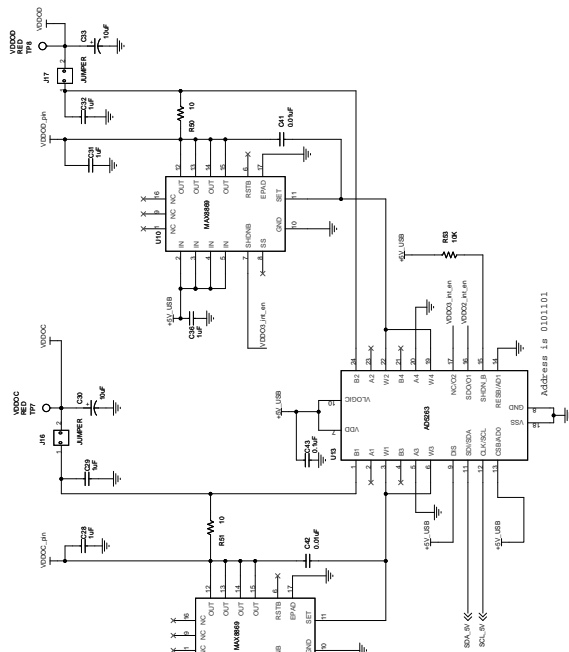

Figure 5. Si5356-EVB MCU Schematic



Voltage Regulators

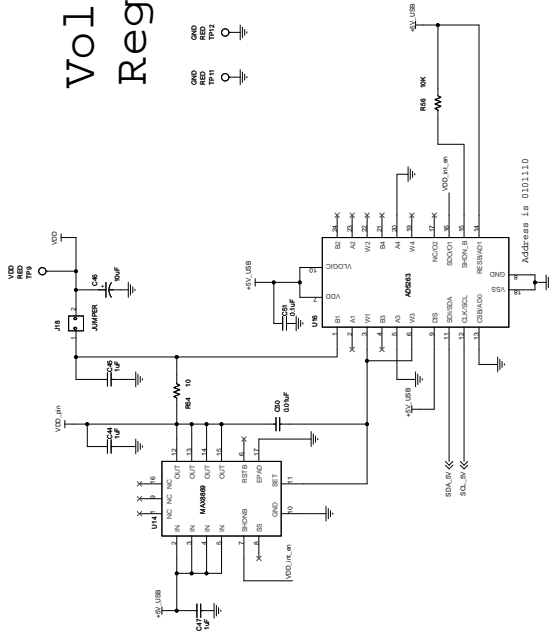

Figure 6. Si5356-EVB Voltage Regulators Schematic

4. Si5356-EVB Bill of Materials

Table 1. Si5356-EVB Bill of Materials

Item	Qty	Reference	Value	Voltage	Tol	PCB Footprint	Mfr	Mfr Part Number
1	18	C1,C2,C3,C4, C5,C6,C9,C10, C11,C12,C13, C16,C17,C18, C19,C40,C43, C51	0.1 μ F	10 V	\pm 10%	C0402	Venkel	C0402X7R100-104K
2	1	C7	4.7 μ F	10 V	\pm 20%	C1206	Venkel	C1206X7R100-475M
3	3	C8,C15,C20	1 μ F	25 V	\pm 10%	C1206	Venkel	C1206X7R250-105K
4	7	C14,C25,C27, C30,C33,C46, C48	10 μ F	25 V	\pm 20%	6032_EIAC	Kemet	B45196H5106M309
5	17	C22,C23,C24, C26,C28,C29, C31,C32,C34, C35,C36,C39, C44,C45,C47, C49,C52	1 μ F	10 V	\pm 10%	C0603	Venkel	C0603X7R100-105K
6	6	C37,C38,C41, C42,C50,C53	0.01 μ F	10 V	\pm 20%	C0402	Venkel	C0402X7R100-103M
7	1	D1	RED			LED-S-GW-KA	Panasonic	LN1271RAL
8	2	D2,D3	MMBD3004S-7-F	300 V		SOT23-AKC	Diodes Inc.	MMBD3004S-7-F
9	2	D4,D5	GREEN			LED-S-GW-AK	Panasonic	LN1371G
10	8	J1,J2,J3,J5,J6, J8,J9,J10	SMA			SMA-EDGE-5	Johnson Components	142-0701-801
11	1	J7	HEADER 2x3			CONN2X3	Samtec	TSW-103-07-T-D
12	1	J11	HEADER 2x2			CONN2X2	Samtec	TSW-102-07-T-D
13	1	J12	USB Type B			CONN-USB-B	Tyco	292304-1
14	1	J13	5X2 Shrouded Header			CONN2X5-4W	Tyco	5103309-1
15	5	J14,J15,J16, J17,J18	JUMPER			CONN-1X2	Samtec	TSW-102-07-T-S
16	1	R1	4.99 k Ω		\pm 1%	R0402	Venkel	CR0402-16W-4991F
17	19	R2,R3,R4,R5, R6,R8,R9,R10, R11,R12,R13, R14,R18,R19, R22,R23,R34, R35,R37	0 Ω			R0402	Venkel	CR0402-16W-000

Table 1. Si5356-EVB Bill of Materials (Continued)

Item	Qty	Reference	Value	Voltage	Tol	PCB Footprint	Mfr	Mfr Part Number
18	1	R15	10 k Ω		$\pm 1\%$	R0603	Venkel	CR0603-10W-1002F
19	2	R16,R17	2.21 k Ω		$\pm 1\%$	R0603	Venkel	CR0603-10W-2211F
20	2	R20,R21	1 k Ω		$\pm 1\%$	R0603	Venkel	CR0603-10W-1001F
21	4	R24,R25,R45, R46	1.02 k Ω		$\pm 0.1\%$	R0402	Venkel	TFCR0402-16W-E-1021B
22	7	R26,R27,R28, R39,R40,R41, R42	1 k Ω		$\pm 5\%$	R0402	Venkel	CR0402-16W-102J
23	4	R29,R30,R31, R33	2 k Ω		$\pm 1\%$	R0402	Venkel	CR0402-16W-2001F
24	2	R43,R44	220 Ω		$\pm 5\%$	R0402	Venkel	CR0402-16W-221J
25	1	R47	412 Ω		$\pm 1\%$	R0402	Venkel	CR0402-16W-4120F
26	5	R48,R49,R50, R51,R54	10 Ω		$\pm 0.5\%$	R2512	Venkel	CR2512-2W-10R0D
27	4	R52,R53,R55, R56	10 k Ω		$\pm 5\%$	R0402	Venkel	CR0402-16W-103J
28	1	R57	47.5 k Ω		$\pm 1\%$	R0603	Venkel	CR0603-10W-4752F
29	1	R58	15.4 k Ω		$\pm 1\%$	R0603	Venkel	CR0603-10W-1542F
30	1	S1	SW PUSHBUTTON	12 Vdc		SW-PB-MOM	Mountain Switch	101-0161-EV
31	1	TP4	Black			TESTPOINT	Kobiconn	151-203-RC
32	1	U1	Si5356	3.3 V		QFN24N4X4P0 .5	Skyworks	Si5356-A-A-GM
33	1	U2	25 MHz			XTAL4N3.2X2. 5-FA238	Epson	FA-238 25.0000MB
34	1	U3	2.5 V			SOT-23	Analog Devices	AD1582BRT
35	1	U4	PCA9517D			SO8N6.0P1.27	NXP	PCA9517D
36	1	U5	C8051F340	5.5 V		QFP48N9X9P0 .5	Skyworks	C8051F340-GQ
37	2	U6,U7	ADG728	2.7– 5.5 V		TSSOP16N6.4 P0.65	Analog Devices	ADG728BRUZ
38	6	U8,U9,U10, U11,U14,U15	MAX8869			TSSOP16N6.5 P0.65E	Maxim	MAX8869EUE50
39	3	U12,U13,U16	AD5263			TSSOP24N6.4 P0.65	Analog Devices	AD5263BRUZ20

Table 1. Si5356-EVB Bill of Materials (Continued)

Item	Qty	Reference	Value	Voltage	Tol	PCB Footprint	Mfr	Mfr Part Number
40	4						SPC Technology	2397
41	4						Richco	NSS-4-4-01
42	10	Jumpers					Sullins	SPC02SYAN
43	1	C21	10 μ F	25 V	\pm 20%	6032_EIAC	Kemet	B45196H5106M309
44	1	J4	SMA			SMA-EDGE-5	Johnson Components	142-0701-801
45	1	R7	0			R0402	Venkel	CR0402-16W-000
46	13	TP1,TP2,TP3, TP5,TP6,TP7, TP8,TP9,TP10, TP11,TP12, TP13,TP14	RED			TESTPOINT	Kobiconn	151-207-RC

REVISION HISTORY

Revision 0.2 to Revision 0.3

- Changed “ClockBuilder Desktop” to “ClockBuilder Pro” throughout.
- Removed ClockBuilder Desktop Software Installation section.

Revision 0.1 to Revision 0.2

- Changed “Any Rate Clock Generator” to “ClockBuilder Desktop” throughout.
- Changed “MultiSynth Clock Programmer” to “ClockBuilder Desktop” throughout.
- Updated Figure 4 on page 6.
- Removed “Uninstaller Option” figure.
- Updated Figure 9 on page 9.