



SKYWORKS®

Si5XX SINGLE/DUAL FREQUENCY XO/VCXO EVALUATION BOARD

Description

The Skyworks Si5xx evaluation board contains the hardware needed for evaluation of the Si5xx Single/Dual Frequency XO/VCXO.

Note: The Si5xx-EVB is not populated with an Si5xx XO or VCXO. These devices must be ordered separately. Go to www.skyworksinc.com/en/application-pages/timing-lookup-customize to configure a device and/or to order samples.

Features

- Evaluation of Skyworks' Si5xx Single/Dual Frequency XO/VCXO
- Voltage control (VC) input port (Si515, Si516)
- Supports frequencies up to 1.4 GHz (using Si53x/55x)
- Dual footprint supports 3.2 x 5 or 5 x 7 mm

Function Block Diagram

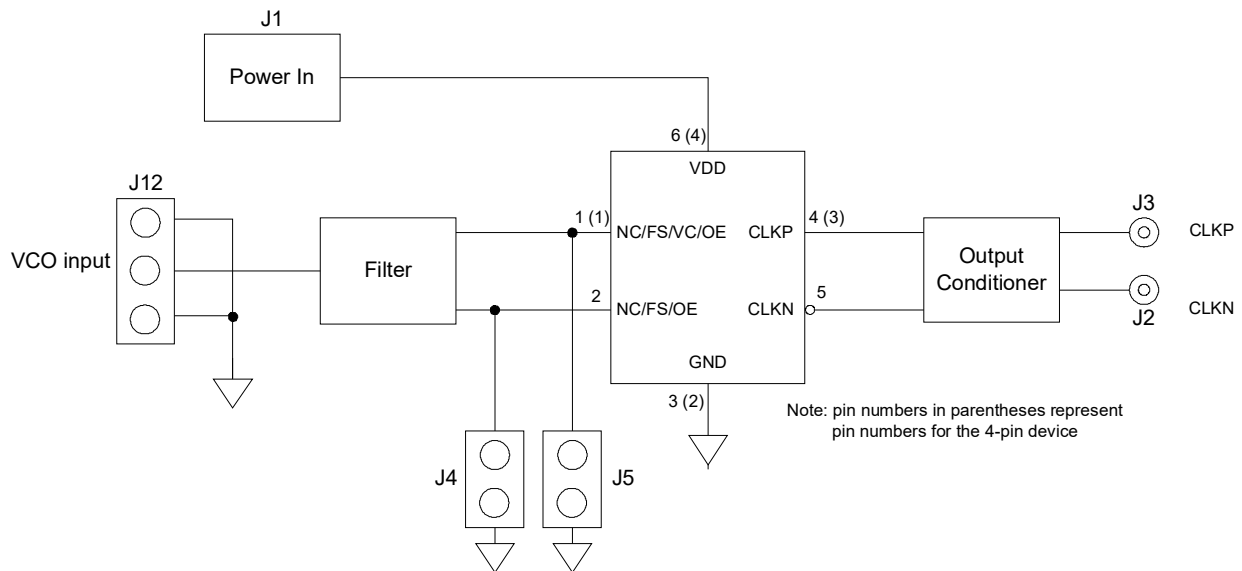

Si5xx-EVB

1. Introduction

This document describes the operation of the Skyworks Si5xx evaluation kit. The Si5xx-EVB kit refers to the evaluation board hardware intended for customer evaluation of the Si5xx single/dual frequency XO/VCXO. The Si5xx-EVB kit contains the following:

- Si5xx-EVB Hardware
- Si5xx-EVB User Guide (this document)

The Si5xx-EVB evaluation board can be used to evaluate all the single and dual frequency Si5xx XO/VCXOs offered by Skyworks:

Table 1. Si5xx XO and VCXO Device Evaluation Board Selector Guide

Part #	Type	Devices Supported	Packages Supported	Output Format, Temp Stability, Tuning Slope	Supported Frequency Range
Si5XX-EVB	Fixed Frequency XO/VCXO Eval Board	Si510/511 Si512/513 Si515/516 Si530/531 Si532/533 Si535/536 Si550/552 Si590/591	5 x 7 mm, 6-pin 3.2 x 5 mm, 6-pin 3.2 x 5 mm, 4-pin	LVPECL CML HCSSL LVDS CMOS Dual-CMOS	100 kHz to 1417 MHz
Note: Si5xx samples must be ordered separately from the Si5xx-EVB.					

1.1. Quick Start

1. Install an Si5xx device on the board.
2. Verify the jumper settings are correct.
3. Connect external power cable to the EVB (set voltage according to how the part was ordered).

2. Top/Bottom Views of Board

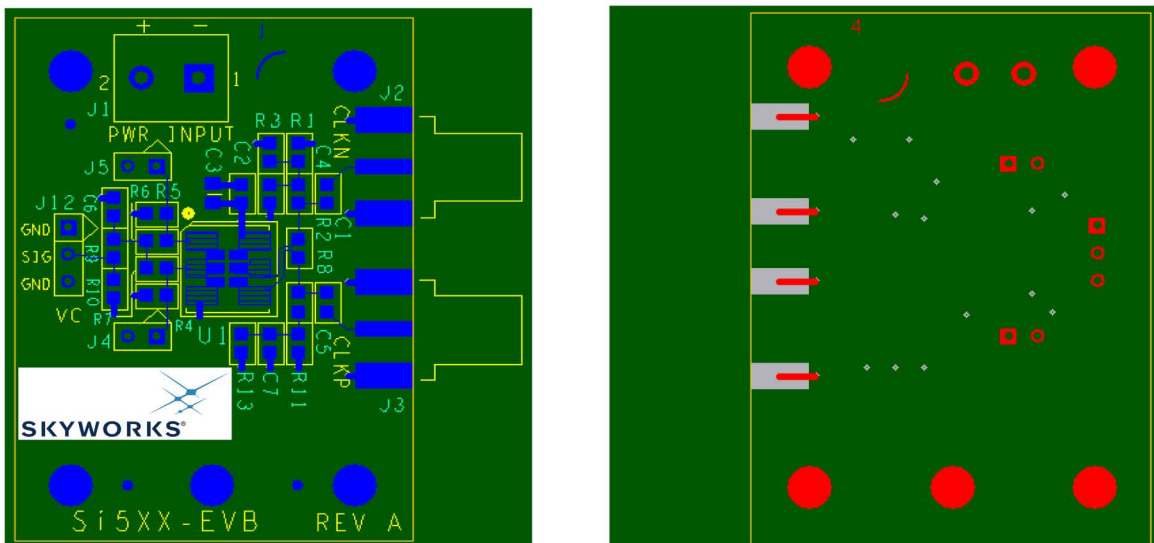

Figure 1. Top (Left) and Bottom (Right) Board Views

3. Functional Description

The Si5xx-EVB is the evaluation board assembly for the Si5xx single/dual frequency XO/VCO. This evaluation board assembly provides access to all signals for operating the device. The Si5xx-EVB schematics, bill of material, and PCB layouts are included as sections 4, 5, and 6, respectively. Figure 2 provides a block diagram for the board.

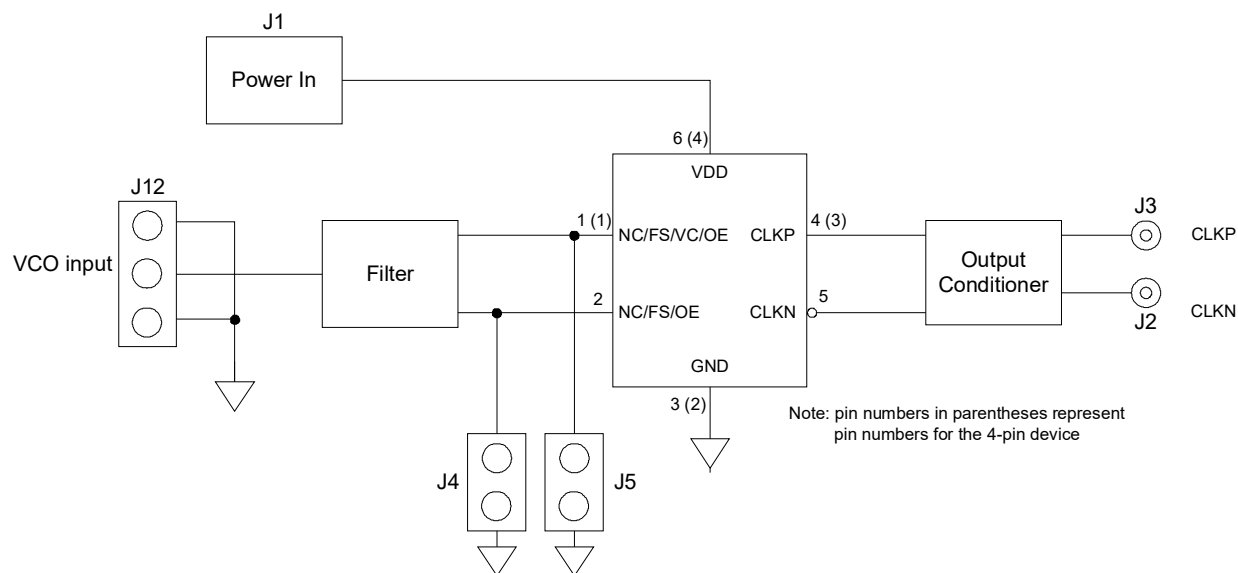

Figure 2. Si5xx-EVB Functional Block Diagram

3.1. Power Supply

The Si5xx-EVB accepts either an external supply of 1.8, 2.5, or 3.3 V at connector J1. (Insure the voltage range of the DUT is obeyed, and it is also good practice to set a current limit on the power supply).

3.2. Jumpers

There are two jumpers on the Si5xx-EVB as listed in Table 2. The board default is to have no jumpers.

Table 2. Si5xx-EVB Jumpers

Component	Si510	Si511	Si512	Si513	Si515	Si516
R6	remove	remove	remove	remove	installed	installed
R7	remove	remove	remove	remove	remove	remove
J4	No jumper: OE = Hi Jumper: OE = Lo	No jumper	No jumper: OE = Hi Jumper: OE = Lo	No jumper: FS = Hi Jumper: FS = Lo	No jumper: OE = Hi Jumper: OE = Lo	No jumper: FS = Hi Jumper: FS = Lo
J5	No jumper	No jumper: OE = Hi Jumper: OE = Lo	No jumper: FS = Hi Jumper: FS = Lo	No jumper: O E= Hi Jumper: OE = Lo	No jumper	No jumper

Si5xx-EVB

3.3. Si5xx-EVB Voltage Control Signal

An external voltage control signal may be applied to the control voltage modulation input at the J12 header (VC). This voltage supplies the control voltage or voltage modulation input to the DUT. See Section 3.2 on how to configure the jumpers and VC enable resistors (R6 and R7).

3.4. Output Terminations

The Si5xx-EVB can support four different output formats: CMOS, LVPECL, LVDS, and HCSL. There are output resistors that are needed to accompany each format. Table 3 shows which resistors are needed for each output:

Table 3. Output Termination Installation Definition

Output Format	R2	R12	R8	R1	R11	R3	R13	C1	C7
CMOS	NP	NP	NP	NP	NP	82	82	100N	100N
LVPECL	0	0	NP	NP	NP	130	130	NP	NP
LVDS	NP	NP	NP	NP	NP	82	82	100N	100N
HCSL	NP	NP	NP	NP	NP	82	82	100N	100N

4. Configuring the Si5xx-EVB

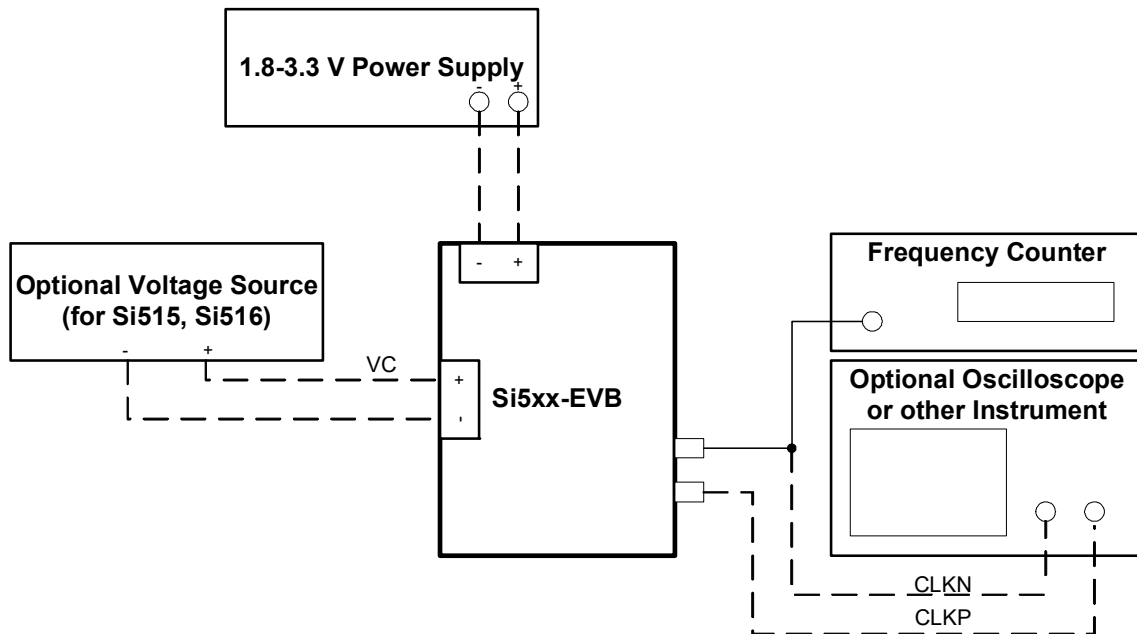

Figure 3. Si5xx-EVB Typical Configuration

5. Schematic

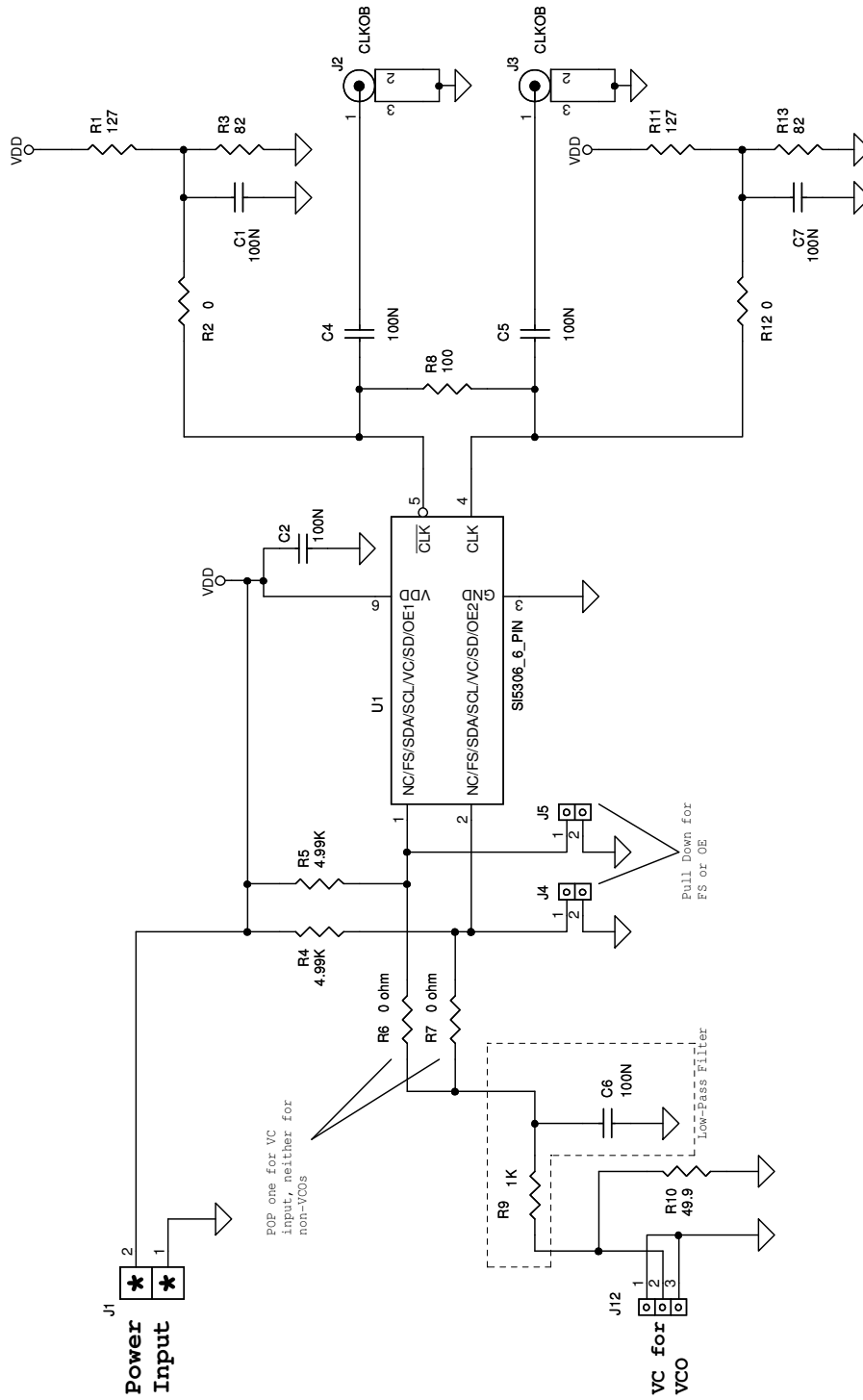

Figure 4. Si5xx-EVB Schematic

Si5xx-EVB

6. Bill of Materials

Table 4. Si5xx-EVB Bill of Materials

Item	Catty	Reference	Value	Mfr	Manufacturer PN	PCB Footprint
1	6	C1,C2,C4,C5, C6,C7	100N	Venkel	C0603X7R160-104KNE	SM_C_0603
2	1	J1	Phoenix- _2_screw	Phoenix	MKDSN 1.5/2-5.08	Phoenix2pinM_p2pitch
3	2	J2,J3	edge mount sma	Johnson	142-0701-801	SMA_EDGE_p062
4	2	J4,J5	1by2_M_Hdr	Salines	Don't care	Thru-hole, .1" pitch
5	1	J12	Jmpr_3pin	Tyco	146225-3	3pin_p1pitch
6	2	R1, R11	127	Venkel	CR0603-16W-127FT	SM_R_0603
7	2	R3, R13	82	Venkel	CR0603-16W-82R0FT	SM_R_0603
8	4	R2, R6, R7, R12	0 ohm	Venkel	CR0603-16W-000T	SM_R_0603
9	1	R10	49.9	Venkel	CR0603-16W-49R9FT	SM_R_0603
10	2	R4,R5	4.99K	Venkel	CR0603-16W-4991FT	SM_R_0603
11	1	R8	100	Venkel	CR0603-16W-1000FT	SM_R_0603
12	1	R9	1K	Venkel	CR0603-16W-1001FT	SM_R_0603
No Pop						
13	0	U1	Si53x	Skyworks	N/A	6_pin_SM
14	0	C3	10UF	Venkel	C0805X5R6R3-106KNE	SM_C_0805

7. Layout

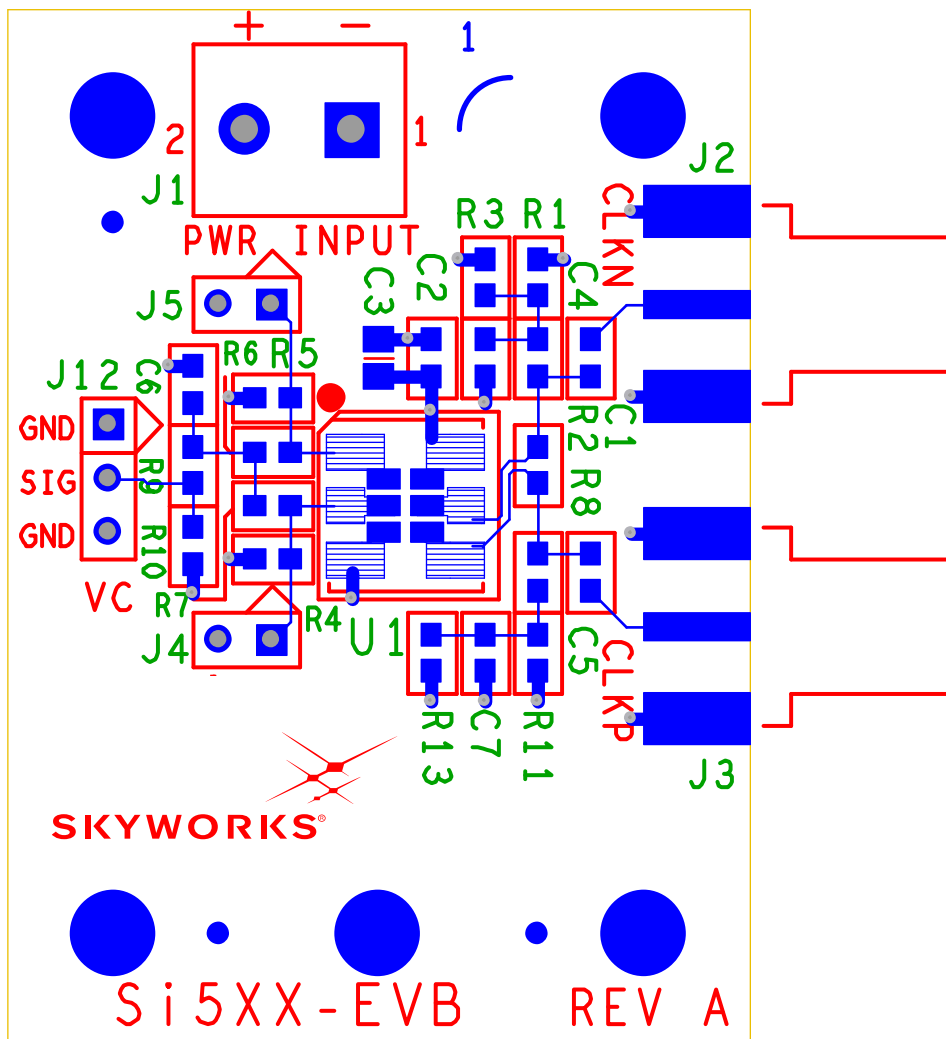

Figure 5. Layer 1: Primary Side

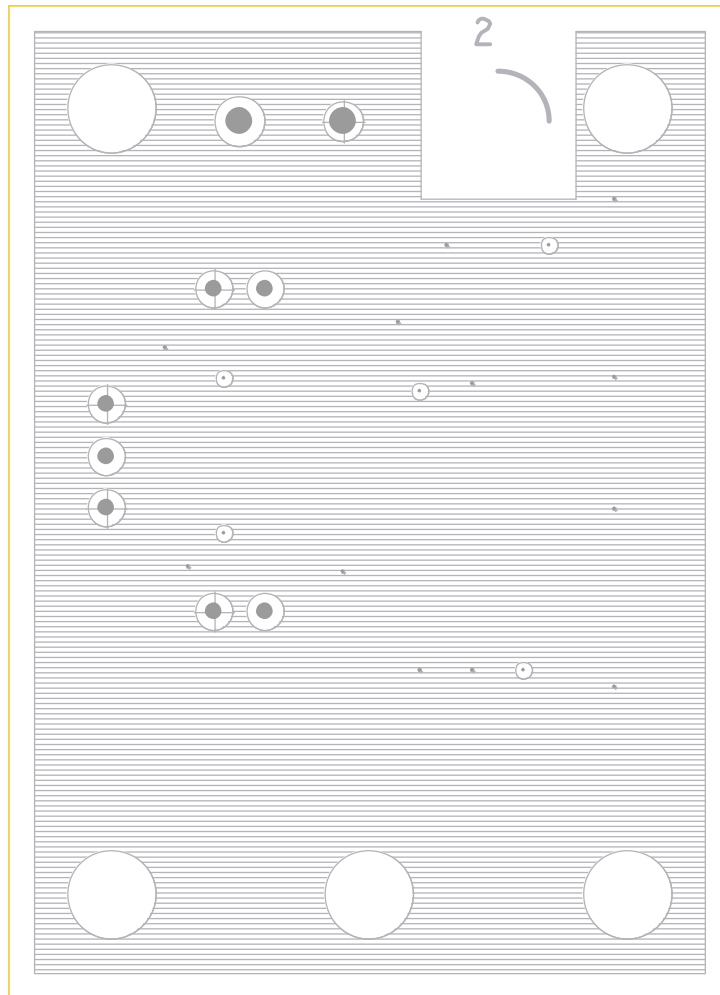

Figure 6. Layer 2: GND

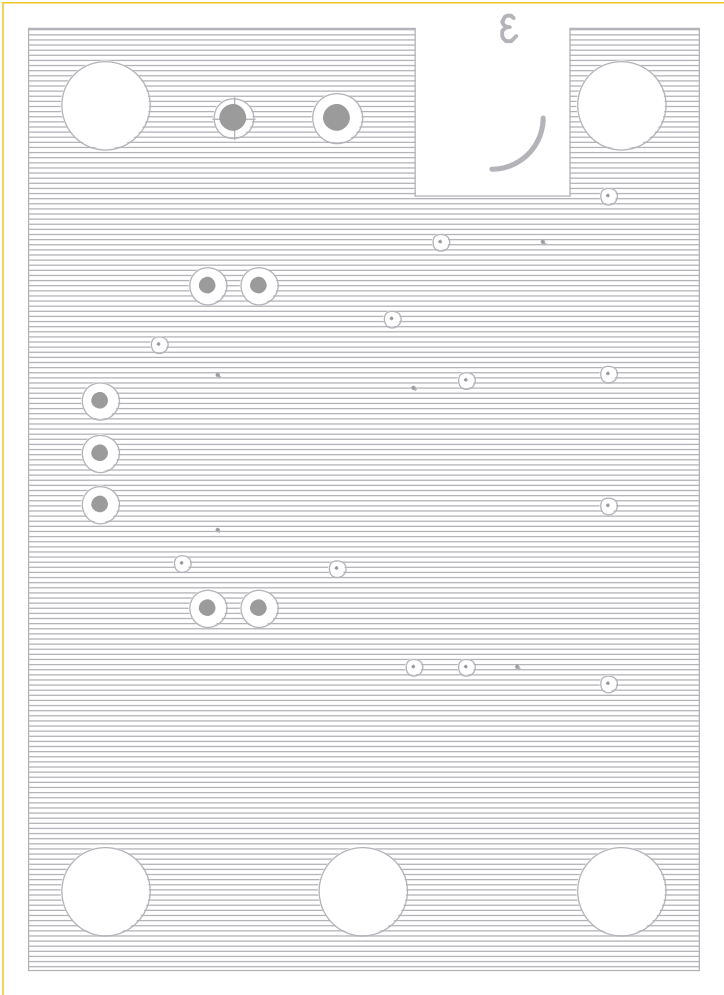

Figure 7. Layer 4: PWR

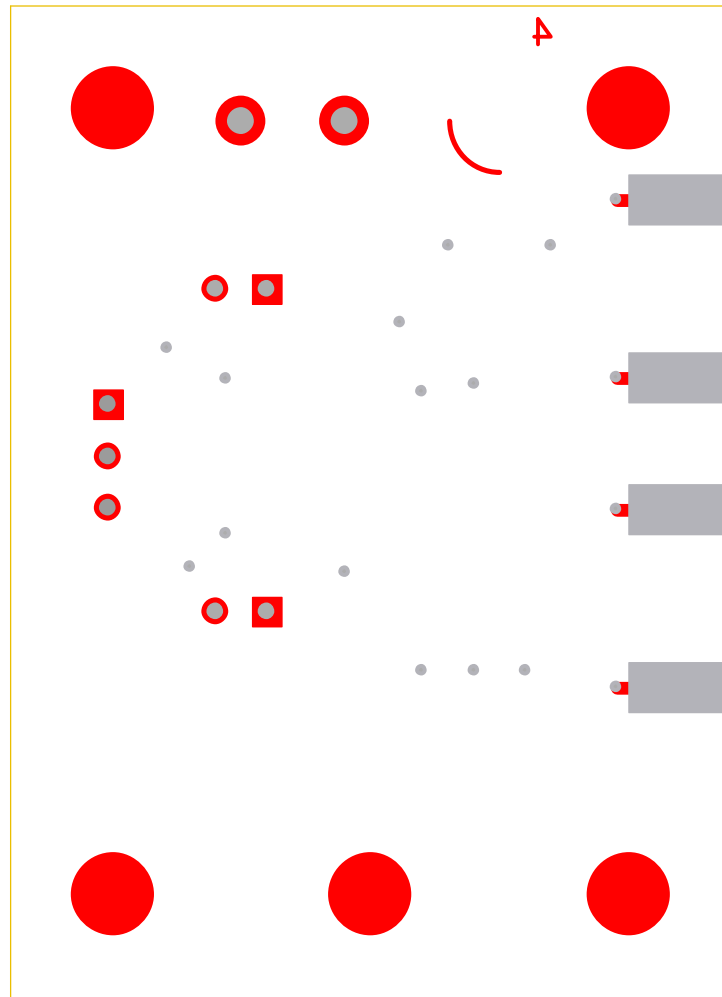

Figure 8. Layer 4: Secondary Side

Document Change List

Revision 0.1 to Revision 0.2

- Added Si535/536 part numbers to Table 1.