



UG466: Si830x4BF-EVB User Guide

Description

The Si830x4BF provides four high-side (sourcing) or low-side (sinking) switches with low R_{ON} at continuous currents of 700 mA. These switches are ideal for driving resistive and inductive loads such as solenoids and relays commonly found in industrial control systems like Programmable Logic Controllers (PLCs). It also includes precise voltage, current, and temperature sensors that continuously monitor the switch and load conditions, protecting the device by reducing driver performance or forcing a controlled shutdown when necessary.

The Si830x4BF evaluation board allows designers to evaluate Skyworks' Si830x4BF family of Smart Switches. The boards come populated with two Si830x4BF devices, the Si83004BF(sourcing) and the Si83014BF(sinking).

The board includes Fault LED status indicators and test points on each of the devices' pins to accommodate direct connection to the designer's end system. The board also integrates an optocoupler-based isolated input logic interface, and a power supply protection circuit along with reverse voltage protection and over-voltage protection. Additional information on the Si830x4BF products can be found at <https://www.skyworksinc.com/Products/Isolation>. The product data sheet and application notes can be referenced to help facilitate designs.

Applications

- Si830x4BF base board
 - Si83004BF-IT
 - Si83014BF-IT
- Optional isolated optocoupler inputs
- Sourcing Switch
- Sinking Switch
- Power supply protection circuit

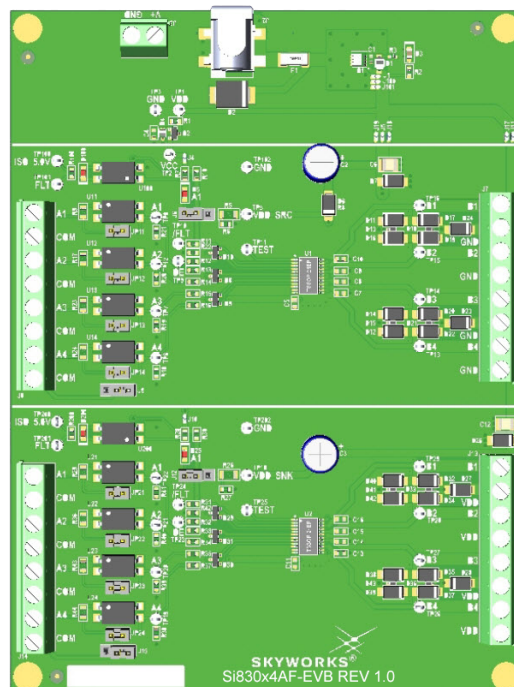

1. Required Equipment

The following equipment is required to demonstrate the evaluation board features:

- One dual-channel dc power supply or two single supplies: 0-24 V dc supply and isolated 0-5 V dc supply
- One oscilloscope with at least 2 channels
- Eight 10 k Ω through-hole resistors with $\geq 1/4$ W power rating (1 minimum)
- One function generator (optional)
- Si830x4BF-EVB kit
- Si830x4BF-EVB User's Guide (this document)
- Assorted cables, leads, and probes as necessary to connect equipment to EVB

2. Test Setup

2.1. DC Supply Configuration

1. Ensure that JS1 and JS7 are in the default positions between Pins 1 and 2 of J6 and J12, respectively.
2. Connect TP9 (OE) to TP2 (5 V VCC).
3. Connect TP23 (OE) to TP2 (5 V VCC).
4. Set 24 V dc supply to output 0 V_{DC}.
5. Turn OFF the supply.
6. Connect the 24 V dc supply positive lead to VDD (J2, J3 or TP1).
7. Connect the 24 V dc supply negative lead to GND (J2, J3 or TP3).
8. Turn ON the dc power supply.
9. Slowly ramp 24 V dc supply from 0 V to 8 V.
10. Ensure that LEDs D3, D5, and D25 turn on.
11. Ramp 24 V dc supply from 8 V to 24 V.
12. Ensure that LEDs D5 and D25 turn off.
13. Ensure that the current draw is less than 40 mA. If it is larger, this indicates that either the board or Si830x4BF device has been damaged.

2.2. Input Connections Configuration

The board integrates an optocoupler-based isolated input logic interface for A1-A4 inputs and /FLT output via different jumper settings. These jumper settings are described below.

2.2.1. Sourcing Switch Configuration (U1 Device)

Direct Input Connection

- By default, the jumper shunts at JP11, JP12, JP13 and JP14 must be in place (default position).
- Install the jumper shunts at J6 and J9 between Pin 1 and Pin 2 respectively (default position).

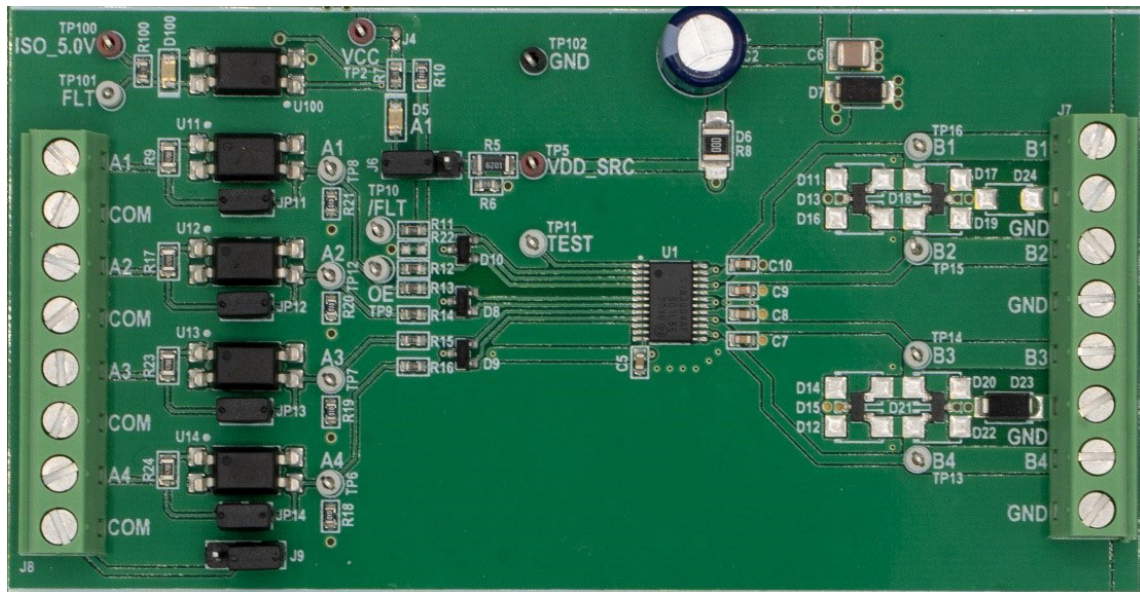

Figure 1. U1 Direct Input Configuration

Optocoupler-Based Isolated Input Connection

- The jumper shunts at JP11, JP12, JP13 and JP14 must be removed (non-default position).
- Install the jumper shunts at J6 and J9 between Pin 3 and Pin 2 respectively (non-default position).
- 5 V dc supply must be applied for /FLT output (connect the 5 V dc supply positive lead to TP100 (ISO_5.0 V) and negative lead to J8 Pin 1).

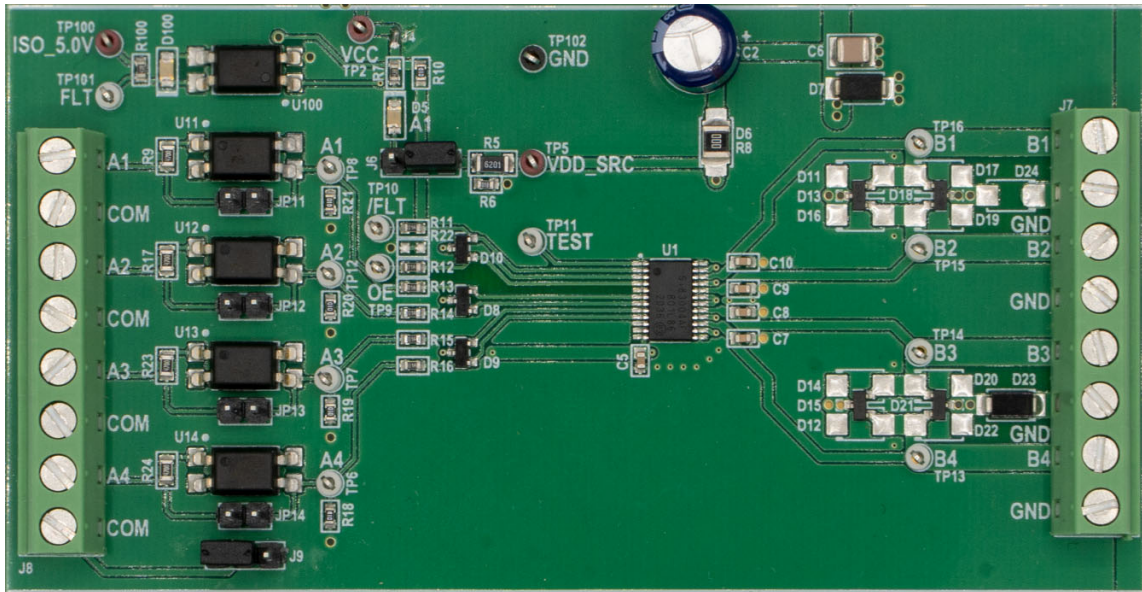

Figure 2. U1 Optocoupler-Based Isolated Input Configuration

2.2.2. Sinking Switch Configuration (U2 Device)

Direct Input Connection

- By default, the jumper shunts at JP21, JP22, JP23 and JP24 must be in place (default position).
- Install the jumper shunts at J12 and J15 between Pin 1 and Pin 2 respectively (default position).

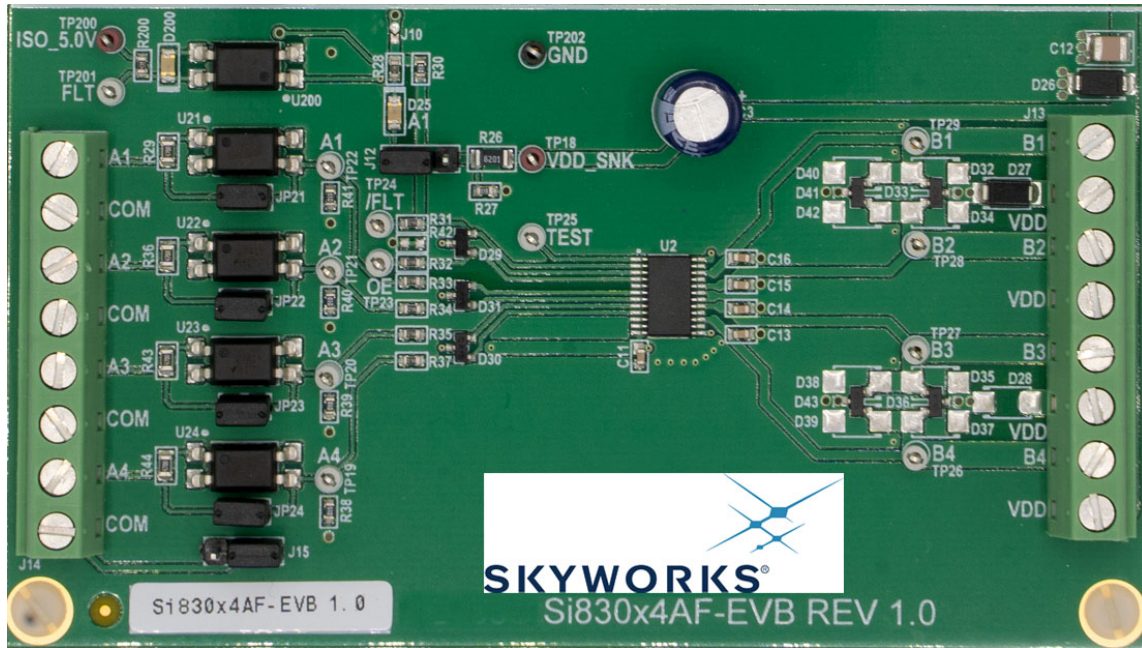

Figure 3. U2 Direct Input Configuration

Optocoupler-Based Isolated Input Connection

- The jumper shunts at JP21, JP22, JP23 and JP24 must be removed (non-default position).
- Install the jumper shunts at J12 and J15 between Pin3 and Pin2 respectively (non-default position).
- 5 V dc supply must be applied for /FLT output (connect the 5 V dc supply positive lead to TP200 (ISO_5.0 V) and negative lead to J14 Pin 1).

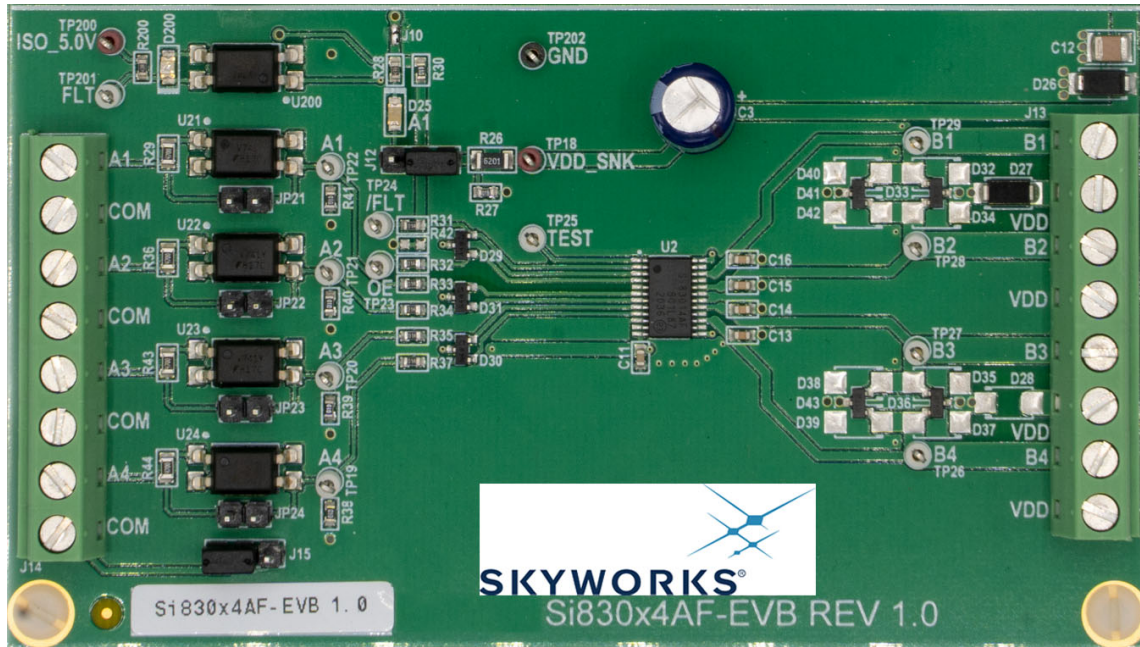

Figure 4. U2 Optocoupler-based Isolated Input Configuration

2.3. Quick Reference Tables

Table 1. Test Point Description

Test Point	Description	Associated DUT:	Referenced to:	Color
TP3	GND	U1, U2	—	BLACK
TP1	VDD		GND	RED
TP2	VCC		GND	RED
TP100	ISO_5.0V	U1	COM (J8 Pin 1)	RED
TP101	FLT		COM (J8 Pin 1)	WHITE
TP102	GND		—	BLACK
TP5	VDD_SRC		GND	RED
TP8	A1		GND	WHITE
TP12	A2		GND	WHITE
TP7	A3		GND	WHITE
TP6	A4		GND	WHITE
TP9	OE		GND	WHITE
TP10	/FLT		GND	WHITE
TP11	TEST		GND	WHITE
TP16	B1		GND	WHITE
TP15	B2		GND	WHITE
TP14	B3		GND	WHITE
TP13	B4		GND	WHITE
TP200	ISO_5.0V		U2	COM (J14 Pin 1)
TP201	FLT	COM (J14 Pin 1)		WHITE
TP202	GND	—		BLACK
TP18	VDD_SNK	GND		RED
TP22	A1	GND		WHITE
TP21	A2	GND		WHITE
TP20	A3	GND		WHITE
TP19	A4	GND		WHITE
TP23	OE	GND		WHITE
TP24	/FLT	GND		WHITE
TP25	TEST	GND		WHITE
TP29	B1	GND		WHITE
TP28	B2	GND		WHITE
TP27	B3	GND	WHITE	
TP26	B4	GND	WHITE	

Table 2. Jumper Header Description

Jumper Header	Corresponding Jumper Shunt in EVB Schematic	Description	Associated DUT:	Direct Input Connection (Default)	Optocoupler-based Isolated Input Connection	
JP11	JS2	A1 Input Direct Connection	U1	In place	Removed	
JP12	JS3	A2 Input Direct Connection		In place	Removed	
JP13	JS4	A3 Input Direct Connection		In place	Removed	
JP14	JS5	A4 Input Direct Connection		In place	Removed	
J9	JS6	COM ground selection (direct GND or isolated Optocoupler GND)		JS6 between J9 Pin 1 and Pin 2	JS6 between J9 Pin 3 and Pin 2	
J6	JS1	Fault LED indicator selection (direct /FLT LED indicator or isolated FLT LED indicator)		JS1 between J6 Pin 1 and Pin 2	JS1 between J6 Pin 3 and Pin 2	
JP21	JS8	A1 Input Direct Connection		U2	In place	Removed
JP22	JS9	A2 Input Direct Connection			In place	Removed
JP23	JS10	A3 Input Direct Connection	In place		Removed	
JP24	JS11	A4 Input Direct Connection	In place		Removed	
J15	JS12	COM ground selection (direct GND or isolated Optocoupler GND)	JS12 between J15 Pin 1 and Pin 2		JS12 between J15 Pin 3 and Pin 2	
J12	JS7	Fault LED indicator selection (direct /FLT LED indicator or isolated FLT LED indicator)	JS7 between J12 Pin 1 and Pin 2		JS7 between J12 Pin 3 and Pin 2	

3. Sourcing Switch (U1 device) Setup and Demo Test

To run the sourcing switch demo, follow the instructions in “2.1. DC Supply Configuration” on page 3 and “2.2.1. Sourcing Switch Configuration (U1 Device)” on page 4 to properly configure the power supply and the inputs. Then, follow the instructions below to complete the demo.

3.1. Load Configuration

1. Turn OFF the 24 V_{DC} power supply.
2. Connect a 10 kΩ resistor to channel B1 by placing one lead in the first slot of the terminal block (J7) and screwing it down. Place the other lead in the second slot (J7) and screw it down.
3. Populate channels B2, B3, and B4 with the remaining resistors.
4. Turn ON the 24 V supply.

3.2. Oscilloscope Setup

1. Connect the CH1 probe to A1 (TP8) and ground the probe to GND (TP102, J7 Pin 8).
2. Connect the CH2 probe to B1 (J7 Pin 1 or TP16) and ground the probe to GND (TP102, J7 Pin 8).
3. Set the scope to Trigger on a rising edge on CH1 and adjust the trigger level to approximately 2 V.
4. Set CH1 to 2 V per division and CH2 to 10 V per division.

3.3. Function Generator Setup

1. Turn ON the function generator with the output disabled.
2. Adjust the output to provide a 100 Hz, 0 to 5 V peak square wave with 50% duty cycle.
3. Connect the positive lead of the generator to A1 input (J8 Pin8) and ground the connection to COM ground (J8 Pin 7).
4. If possible, configure the function generator for a High-Z (high impedance) load.

Note: If you do not have a waveform generator or prefer not to use one, you may simply apply 5 V to the input channels on the Si83004BF to observe the output channel coming on. The proper configuration is shown in [Figure 5](#).

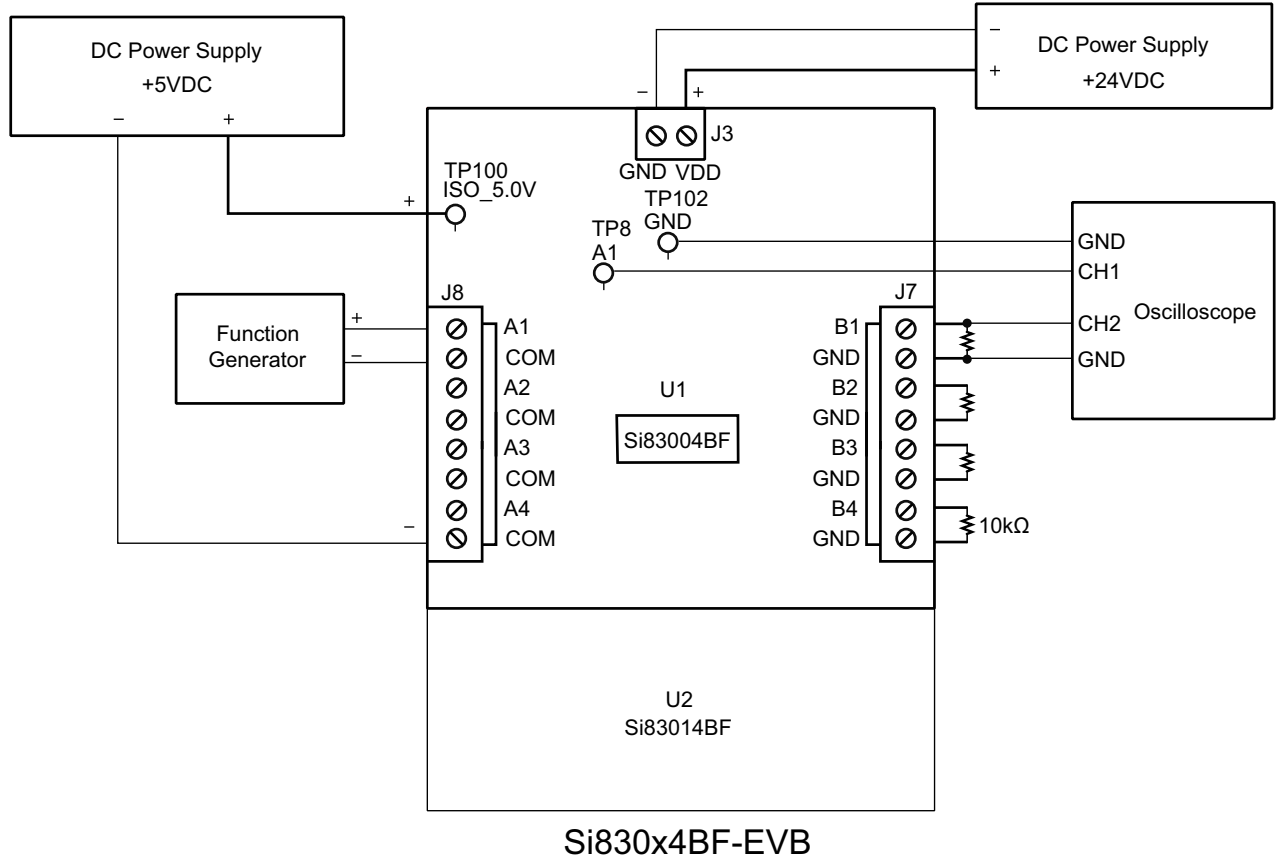

Figure 5. Configuration for Sourcing Switch

3.4. Activate Channels

1. Enable the function generator output on channel A1, or apply 5 V directly.
2. Adjust the vertical and horizontal divisions to properly view the waveform as seen in the image below.
3. Ensure that a 100 Hz square wave with 50% duty cycle appears on Channel 1, and a similar waveform with peak voltage of 24 V appears on Channel 2.

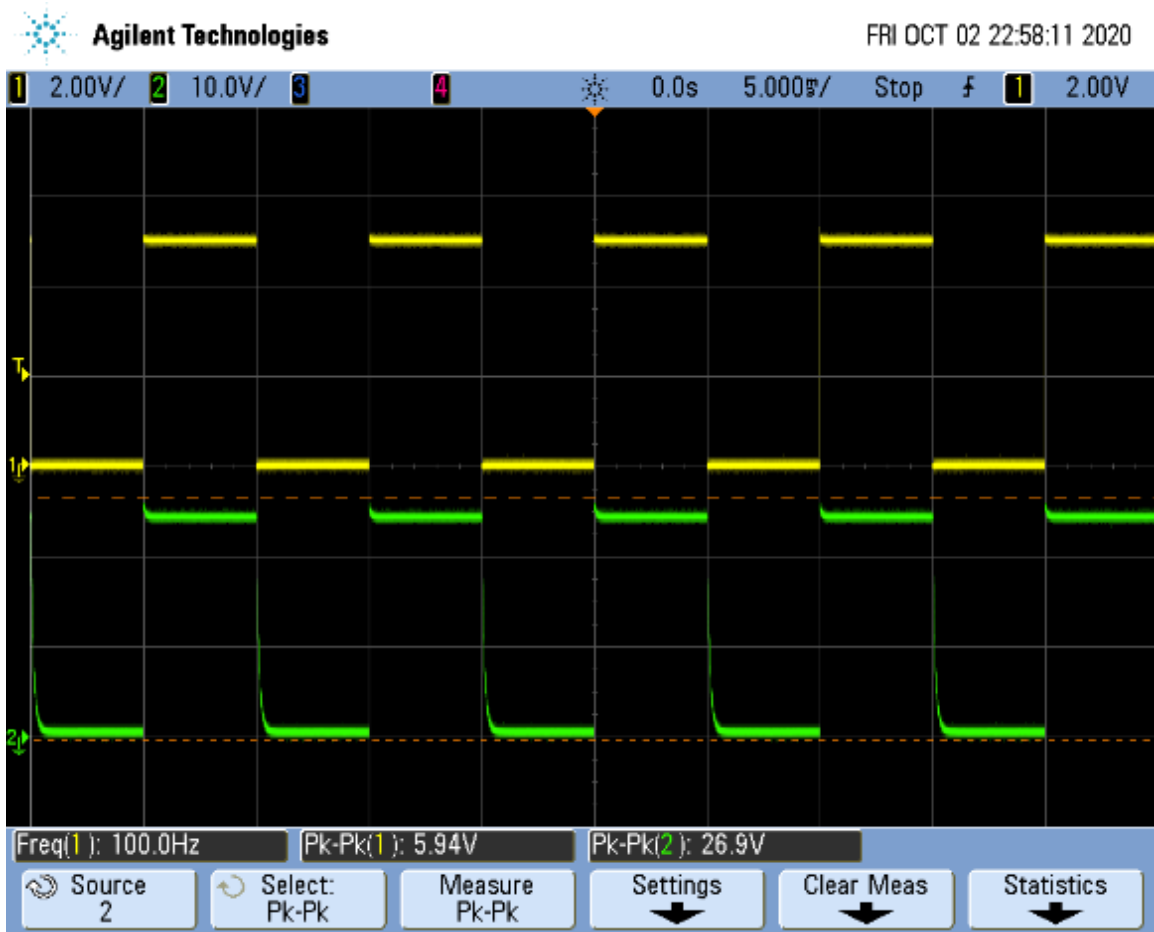

Figure 6. Si83004BF Sourcing Switch Waveform

3.5. Repeat for Remaining Channels

1. Disable the function generator output.
2. Connect the CH1 probe to A2 (TP12).
3. Connect the CH2 probe to B2 (TP15 or J7 Pin 3).
4. Connect the function generator to A2 channel input, positive lead to J8 Pin 6 and negative lead to J8 Pin 5.
5. Enable the function generator.
6. Ensure that a 100 Hz square wave with 50% duty cycle appears on Channel 1, and a similar waveform with peak voltage of 24 V appears on Channel 2.
7. Repeat steps 1-6 with channels A3 and A4 using test points:
 - a. A3 channel test points: A3 (TP7) for CH1 probe, B3 (TP14/J7 Pin 5) for CH2 probe, A3 channel input (J8 Pin 4 and J8 Pin 3).
 - b. A4 channel test points: A4 (TP6) for CH1 probe, B4 (TP13/J7 Pin 7) for CH2 probe, A4 channel input (J8 Pin 2 and J8 Pin 1).

4. Sinking Switch (U2 Device) Setup and Demo Test

To run the sinking switch demo, please follow the instructions in “2.1. DC Supply Configuration” on page 3 and “2.2.2. Sinking Switch Configuration (U2 Device)” on page 6 to properly configure the power supply and the inputs. Then, follow the instructions below to complete the demo.

4.1. Load Configuration

1. Turn OFF the 24 V_{DC} power supply.
2. Connect a 10 kΩ resistor to channel B1 by placing one lead in the first slot of the terminal block (J13) and screwing it down. Place the other lead in the second slot (J13) and screw it down.
3. Populate channels B2, B3, and B4 with the remaining resistors.
4. Turn ON the 24 V supply.

4.2. Oscilloscope Setup

1. Connect the CH1 probe to A1 (TP22) and ground the probe to GND (TP202).
2. Connect the CH2 probe to B1 (J13 Pin 1 or TP29) and ground the probe to GND (TP202).
3. Set the scope to Trigger on a rising edge on CH1 and adjust the trigger level to approximately 2 V.
4. Set CH1 to 2 V per division and CH2 to 10 V per division.

4.3. Function Generator Setup

1. Turn ON the function generator with the output disabled.
2. Adjust the output to provide a 100 Hz, 0 to 5 V peak square wave with 50% duty cycle.
3. Connect the positive lead of the generator to A1 input (J14 Pin 8) and ground the connection to COM ground (J14 Pin 7).
4. If possible, configure the function generator for a High-Z (high impedance) load.

Note: If you do not have a waveform generator or prefer not to use one, you may simply apply 5 V to the input channels on the Si83014BF to observe the output channel coming on. The proper configuration is shown in [Figure 7](#).

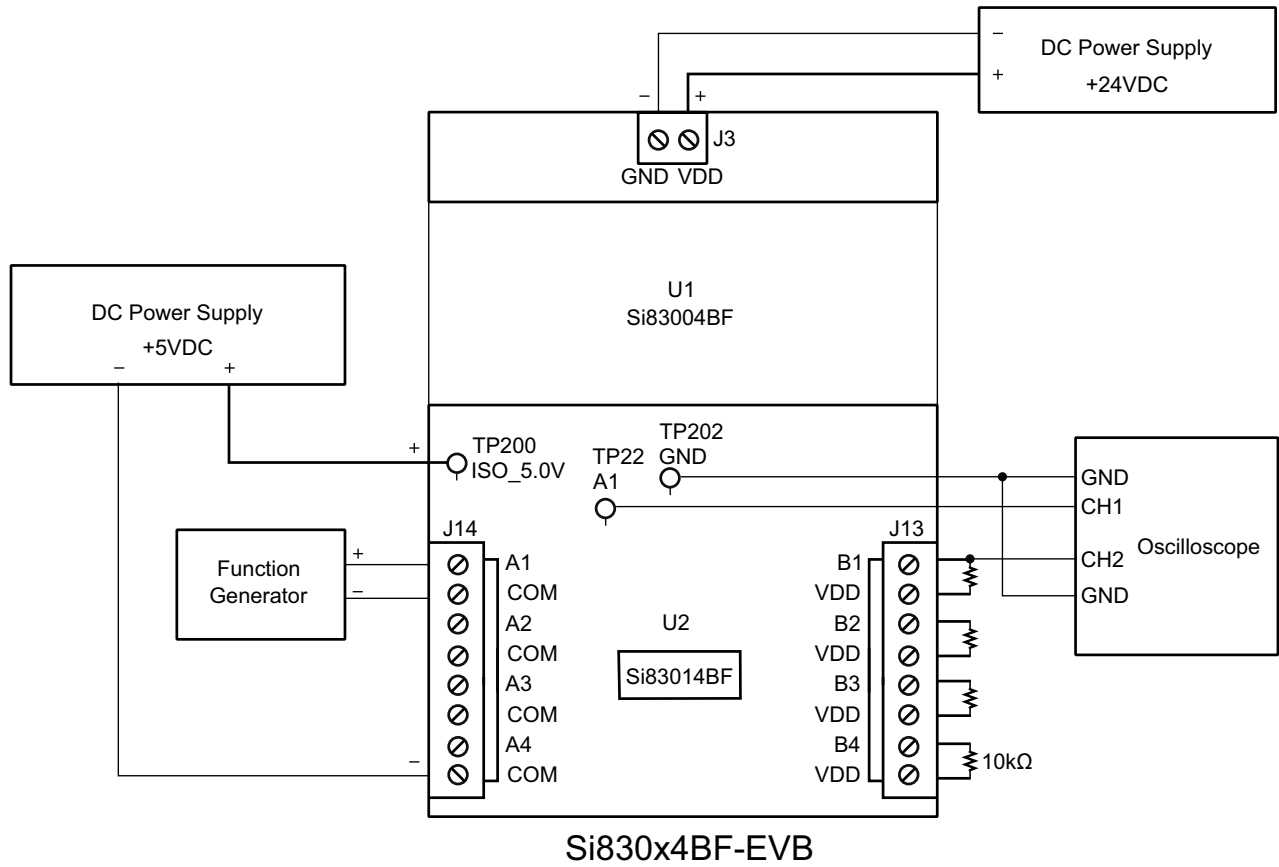

Figure 7. Configuration for Sinking Switch

4.4. Activate Channels

1. Enable the function generator output on channel A1, or apply 5 V directly.
2. Adjust the vertical and horizontal divisions to properly view the waveform as seen in the image below.
3. Ensure that a 100 Hz square wave with 50% duty cycle appears on Channel 1, and a similar waveform with peak voltage of 24 V appears on Channel 2.

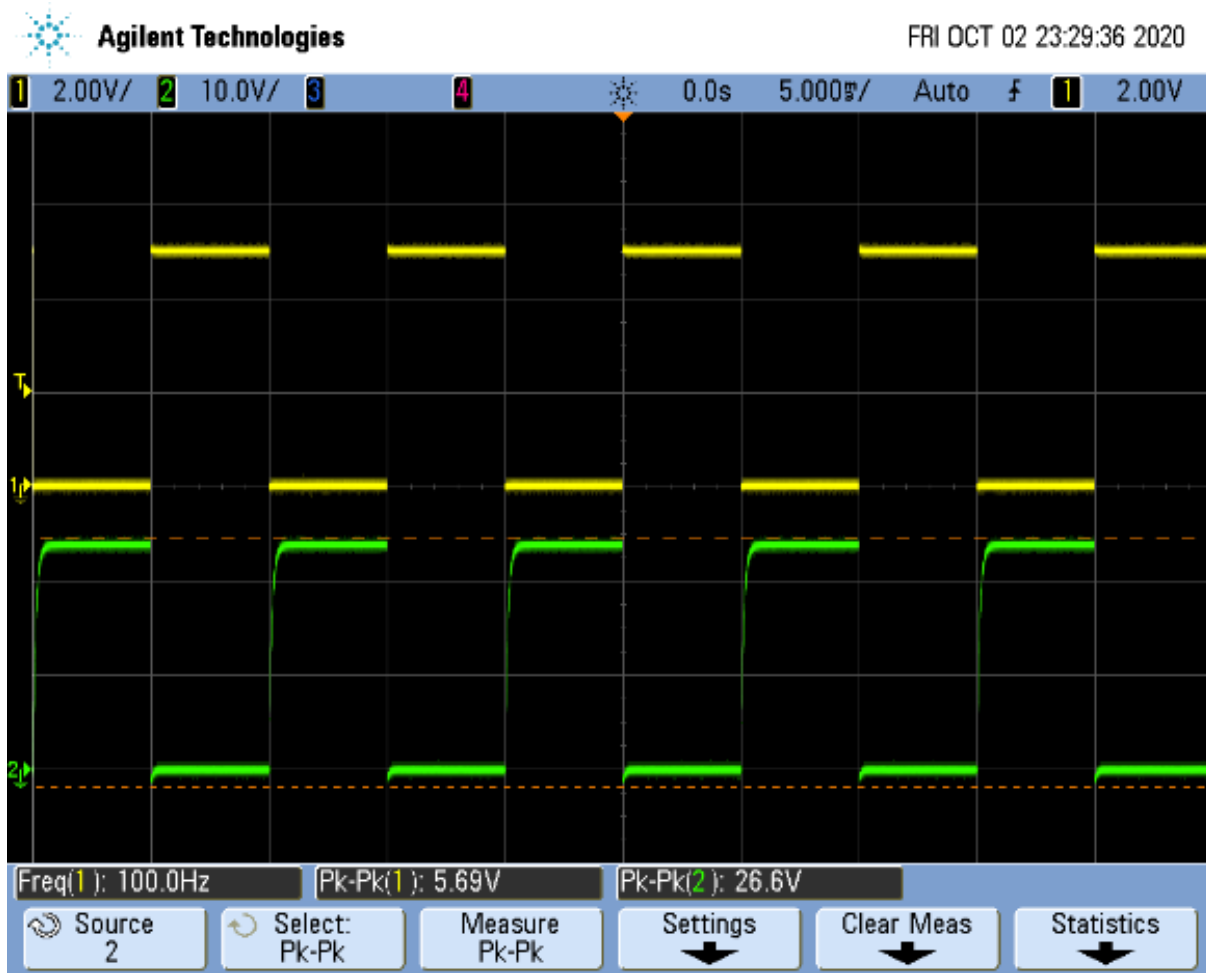

Figure 8. Si83014BF Sinking Switch Waveform

4.5. Repeat for Remaining Channels

1. Disable the function generator output.
2. Connect the CH1 probe to A2 (TP21).
3. Connect the CH2 probe to B2 (TP28 or J13 Pin 3).
4. Connect the function generator to A2 channel input, positive lead to J14 Pin 6 and negative lead to J14 Pin 5.
5. Enable the function generator.
6. Ensure that a 100 Hz square wave with 50% duty cycle appears on Channel 1, and a similar waveform with peak voltage of 24 V appears on Channel 2.
7. Repeat steps 1-6 with channels A3 and A4 using test points:
 - a. A3 channel test points: A3 (TP20) for CH1 probe, B3 (TP27/J13 Pin 5) for CH2 probe, A3 channel input (J14 Pin 4 and J14 Pin 3).
 - b. A4 channel test points: A4 (TP19) for CH1 probe, B4 (TP26/J13 Pin 7) for CH2 probe, A4 channel input (J14 Pin 2 and J14 Pin 1).

5. Si830x4BF-EVB REV 1.0 Schematic

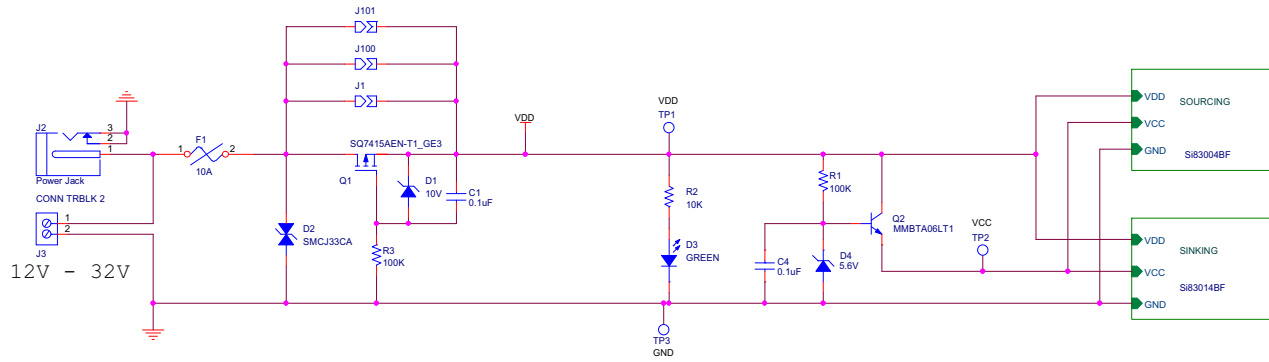

Figure 9. Si830x4BF-EVB Schematic (1 of 3), Power Supply

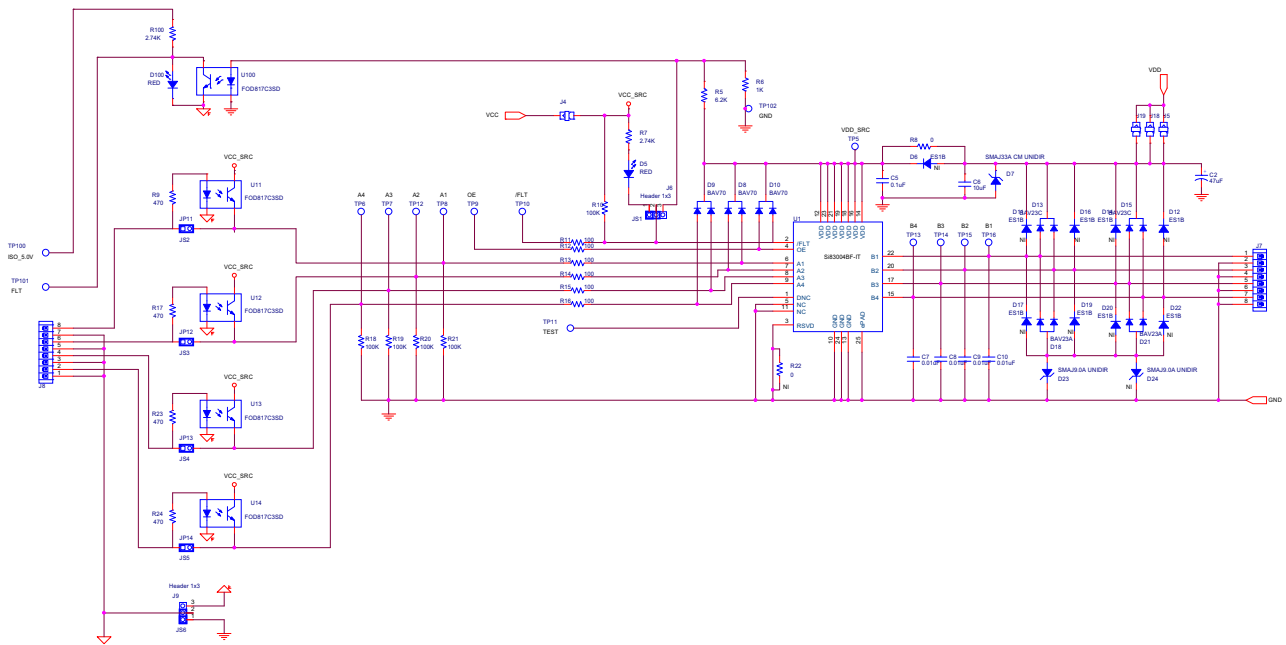

Figure 10. Si830x4BF-EVB Schematic (2 of 3), Sourcing Switch

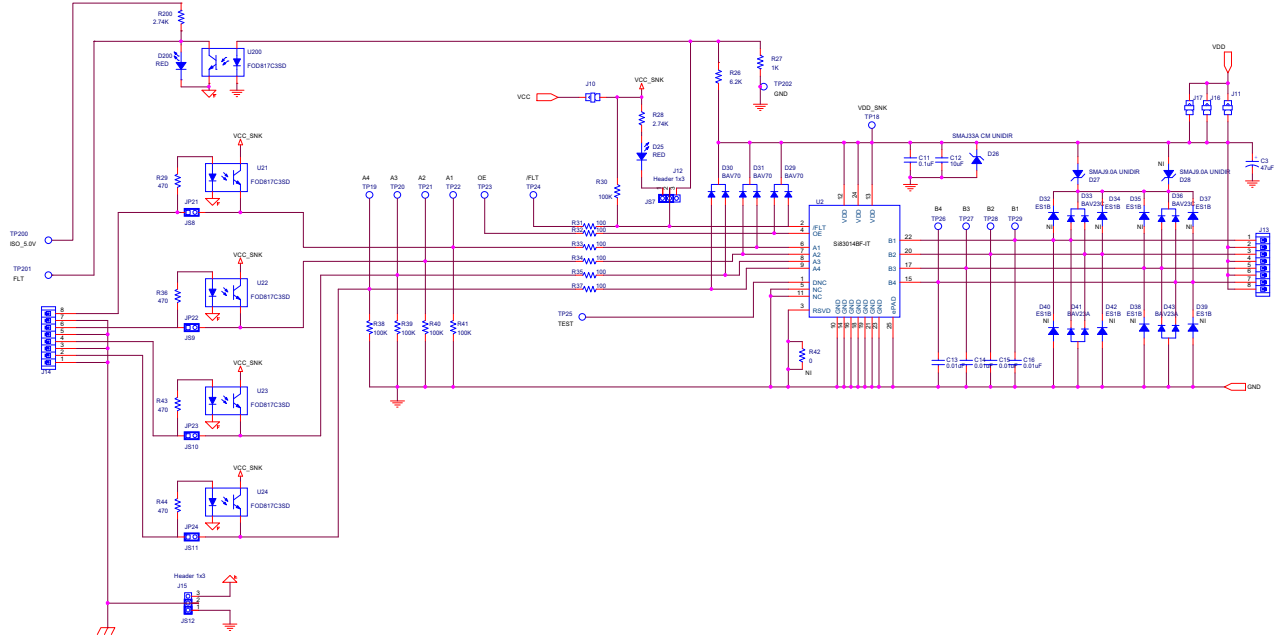

Figure 11. Si830x4BF-EVB Schematic (3 of 3), Sinking Switch

6. Si830x4BF-EVB REV 1.0 Layout

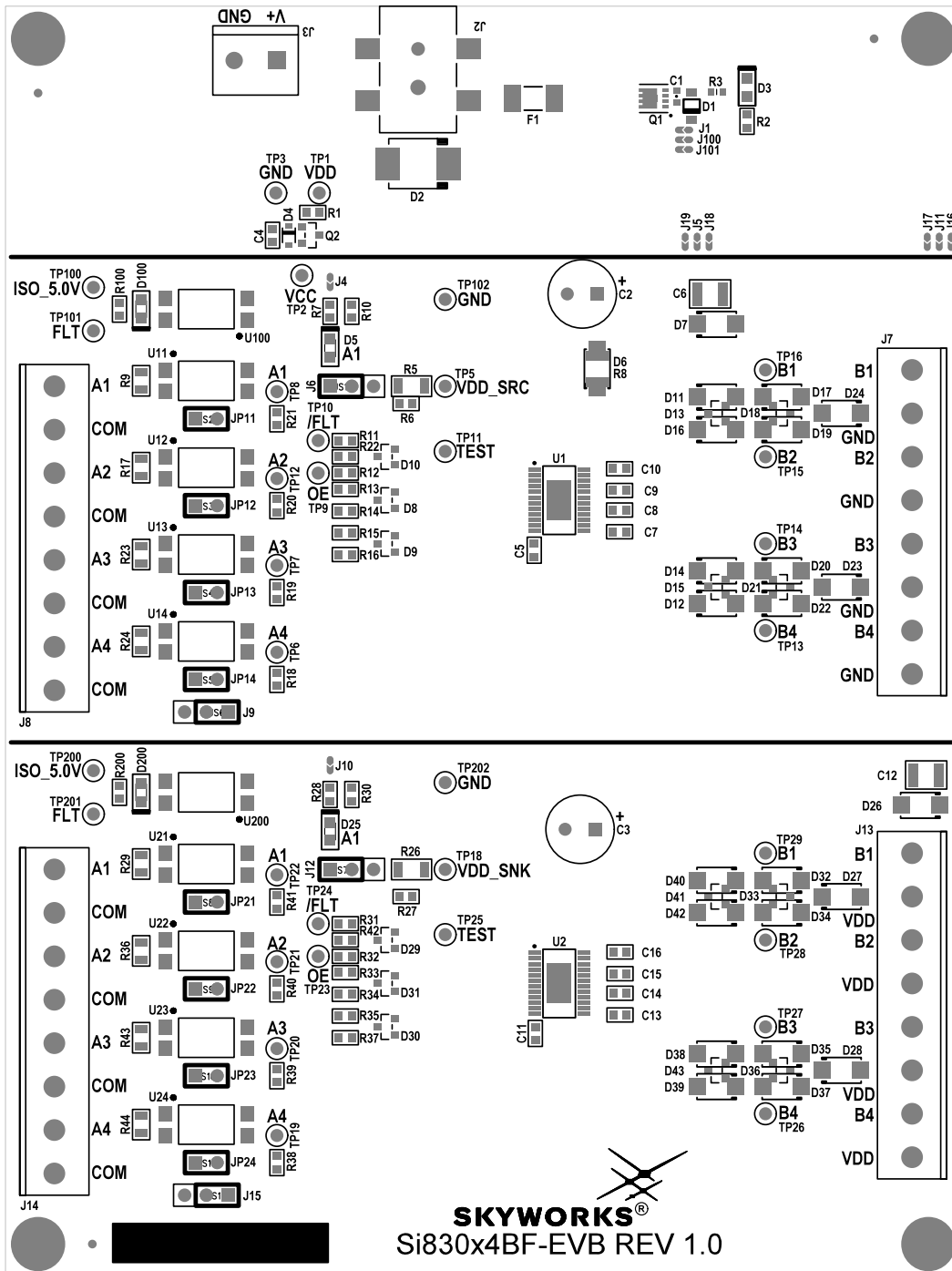

Figure 12. Primary Silkscreen

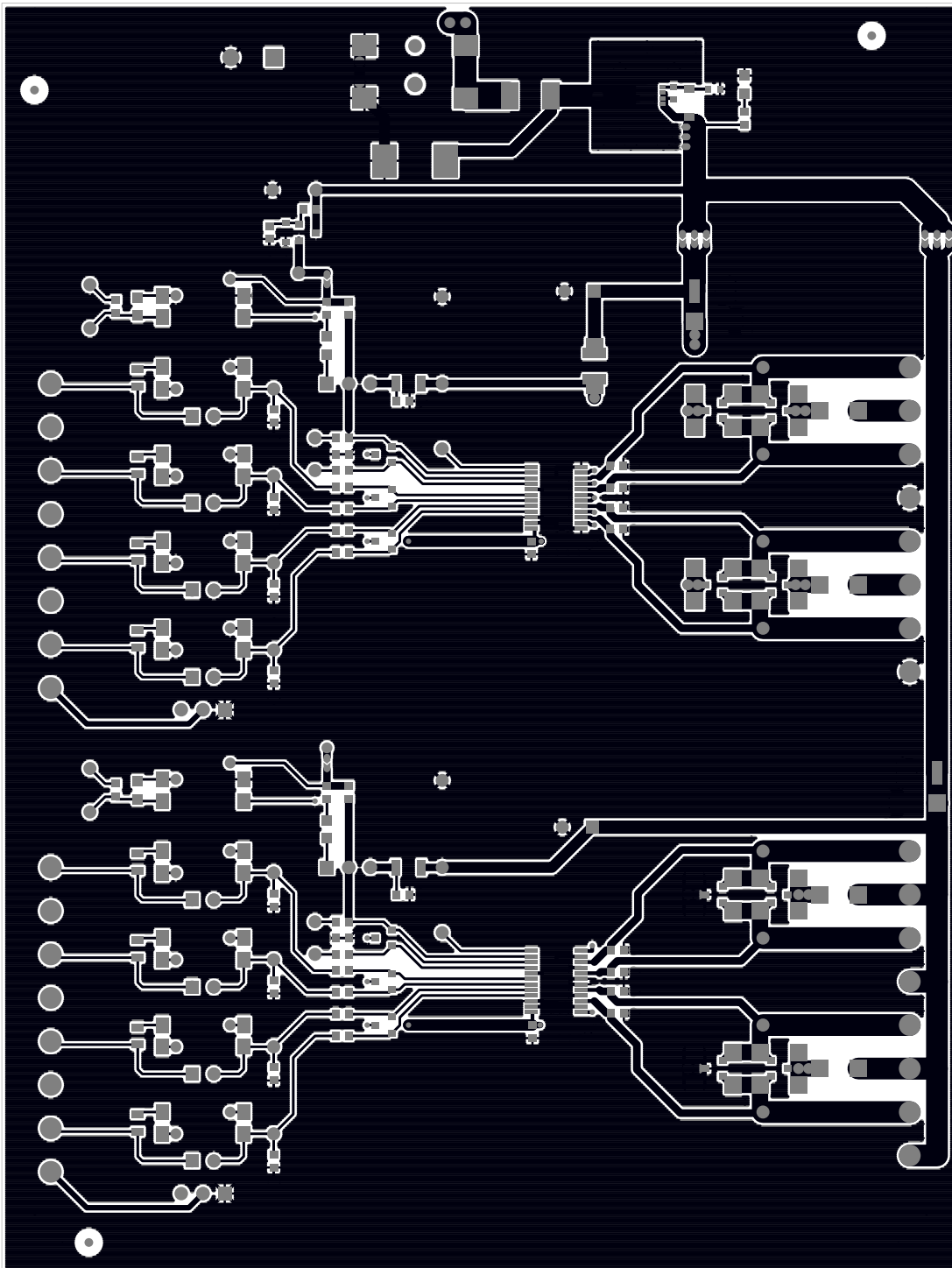

Figure 13. Primary Side

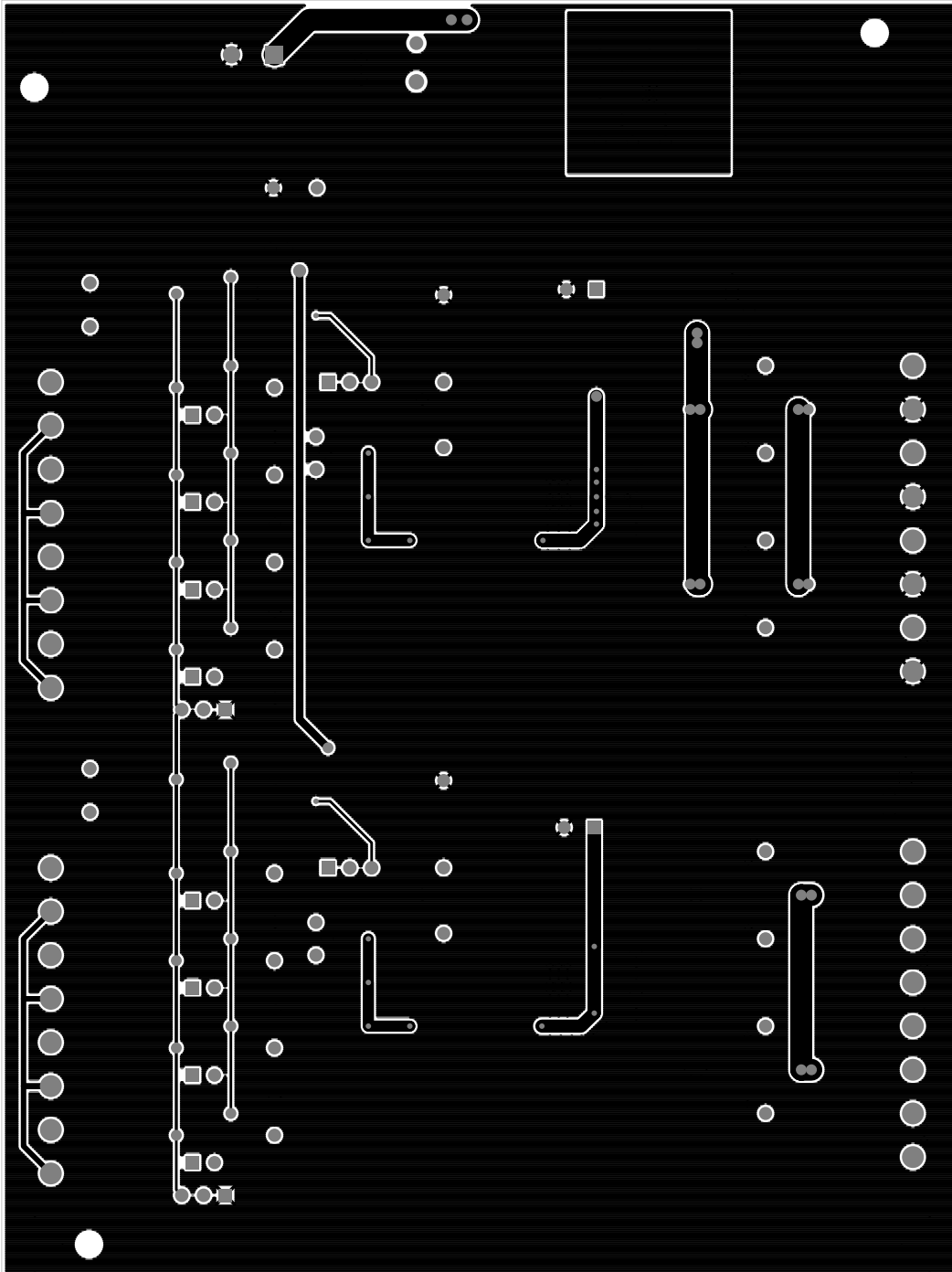

Figure 14. Secondary Side

7. Bill of Materials

Table 3. Si830x4BF-EVB REV 1.0 Bill of Materials (Sheet 1 of 2)

Qty	Ref	Value	Rating	Voltage	Tol	Type	PCB Footprint	Mfr Part Number	Mfr
4	C1 C4 C5 C11	0.1 uF		50 V	±10%	X7R	C0603	C0603X7R500-104K	Venkel
2	C2 C3	47 uF		100 V	±20%	Alum_Elec	C3.5X8MM-RAD	ECA2AM470	Panasonic
2	C6 C12	10 uF		50 V	±20%	X7R	C1210	C1210X7R500-106M	Venkel
8	C7 C8 C9 C10 C13 C14 C15 C16	0.01 uF		100 V	±10%	X7R	C0603	C0603X7R101-103K	Venkel
1	D1	10 V	500 mW	10 V	5%	Zener	SOD-123	MMSZ4697T1G	On Semi
4	D13 D15 D33 D36	BAV23C	400 mA	200 V		Dual Common Cathode	SOT23-AAK	BAV23C	Diodes Inc.
4	D18 D21 D41 D43	BAV23A	400mA	200 V		Dual Common Anode	SOT23-AAK	BAV23A	Diodes Inc.
1	D2	SMCJ33C A	1500 W	33 V		TVS	DO-214AB	SMCJ33CA	Littelfuse
2	D23 D27	SMAJ9.0A UNIDIR	400 W	10 V	5%	TVS	DO-214AC	SMAJ9.0A-E3/61	Vishay
1	D3	GREEN	30 mA	2.2 V		SMT	LED-0805-K	LTST-C170GKT	LITE_ON INC
1	D4	5.6 V	200 mW	5.6 V	7%	Zener	SOD-323	BZT52C5V6S-F-7	Diodes Inc.
4	D5 D25 D100 D200	RED	30 mA	1.8 V		SMT	LED-0805-A	Q62702P5182	Osram
2	D7 D26	SMAJ33A CM UNIDIR	400 W	33 V	5%	TVS	DO-214AC	SMAJ33A-E3/61	Vishay
6	D8 D9 D10 D29 D30 D31	BAV70	215 mA	100 V		Dual Common Cathode	SOT23-AAK	BAV70	NXP
1	F1		10 A	125 V		GP	FUSE-453	0453 010	Littelfuse
1	J2	Power Jack	5 A			BARREL	CONN-3-PWR-SMT	PJ-002AH-SMT	CUI
1	J3	CONN TRBLK 2				TERM BLK	CONN-1X2-TB	1729018	Phoenix Contact
4	J6 J9 J12 J15	Header 1x3				Header	CONN-1X3	TSW-103-07-G-S	Samtec
4	J7 J8 J13 J14	CONN TRBLK 8				TERM BLK	CONN-TB-1729186	1729186	Phoenix Contact
8	JP11 JP12 JP13 JP14 JP21 JP22 JP23 JP24	HEADER 1X2				Header	CONN1X2	TSW-102-07-T-S	Samtec
12	JS1 JS2 JS3 JS4 JS5 JS6 JS7 JS8 JS9 JS10 JS11 JS12	Jumper Shunt				Shunt	N/A SHUNT	SNT-100-BK-T	Samtec
4	MH1 MH2 MH3 MH4	4-40				SCREW	MH-125NP MH-125	NSS-4-4-01	Richco Plastic Co
1	Q1	SQ7415AE N-T1_GE3	16 A	-60 V		P-CHNL	POWER33	SQ7415AEN-T1_GE3	Vishay
1	Q2	MMB- TA06LT1	500 mA	80 sV		NPN	SOT23-BEC	MMBTA06LT1	On Semi

Table 3. Si830x4BF-EVB REV 1.0 Bill of Materials(Continued)(Sheet 2 of 2)

Qty	Ref	Value	Rating	Voltage	Tol	Type	PCB Footprint	Mfr Part Number	Mfr
12	R1 R3 R10 R18 R19 R20 R21 R30 R38 R39 R40 R41	100K	1/16 W		±5%	ThickFilm	R0603	CR0603-16W-104J	Venkel
12	R11 R12 R13 R14 R15 R16 R31 R32 R33 R34 R35 R37	100	1/10 W		±1%	ThickFilm	R0603 R0603L	CR0603-10W-1000F	Venkel
1	R2	10K	1/10 W		±1%	ThickFilm	R0603	CR0603-10W-1002F	Venkel
2	R5 R26	6.2K	¼ W		±1%	ThickFilm	R1206	CRCW12066K20FKEAHP	Vishay Dale
2	R6 R27	1K	1/10 W		±1%	ThickFilm	R0603	CR0603-10W-1001F	Venkel
4	R7 R28 R100 R200	2.74K	1/16 W		±1%	ThickFilm	R0603	CR0603-16W-2741F	Venkel
1	R8	0	4 A			ThickFilm	R1210	CR1210-4W-000	Venkel
8	R9 R17 R23 R24 R29 R36 R43 R44	470	1/10 W		±1%	ThickFilm	R0805	CR0805-10W-4700F	Venkel
4	SO1 SO2 SO3 SO4	STAND-OFF				STANDOFF		1902D	Keystone Electronics
6	TP1 TP2 TP5 TP18 TP100 TP200	RED				Loop	TESTPOINT	151-207-RC	Kobiconn
3	TP3 TP102 TP202	BLACK				Loop	TESTPOINT	151-203-RC	Kobiconn
24	TP6 TP7 TP8 TP9 TP10 TP11 TP12 TP13 TP14 TP15 TP16 TP19 TP20 TP21 TP22 TP23 TP24 TP25 TP26 TP27 TP28 TP29 TP101 TP201	WHITE				Loop	TESTPOINT	151-201-RC	Kobiconn
10	U11 U12 U13 U14 U21 U22 U23 U24 U100 U200	FOD817C 3SD					SO4N10.16P2.54-AKEC	FOD817C3SD	Vishay
1	LB1	OPN: Si830x4BF -EVB R1.0				POLYIMIDE, WHITE	PTL-14-717	LABEL-Si830x4BF-EVB 1.0	Skyworks
1	PCB1	Si830x4BF TSSOP24 EVB REV 1.0				BARE PCB	N/A	Si830x4BF-EVB REV 1.0	Skyworks
1	U1	Si83004B F-IT				SWITCH	TSSOP24N6.4P0.65E2.8X 4.6	Si83004BF-IT	Skyworks
1	U2	Si83014B F-IT				SWITCH	TSSOP24N6.4P0.65E2.8X 4.6	Si83014BF-IT	Skyworks

Table 4. Si830x4BF-EVB REV 1.0 Not Installed Components

Qty	Ref	Value	Rating	Voltage	Tol	Type	PCB Footprint	Mfr Part Number	Mfr
2	D24 D28	SMAJ9.0A UNIDIR	400 W	10 V	5%	TVS	DO-214AC	SMAJ9.0A-E3/61	Vishay
17	D6 D11 D12 D14 D16 D17 D19 D20 D22 D32 D34 D35 D37 D38 D39 D40 D42	ES1B	1.0 A	100 V		Fast	DO-214AC	ES1B	Diodes Inc.
2	R22 R42	0	1 A			ThickFilm	R0603 R0603L	CR0603-16W-000	Venkel

8. Ordering Guide

Table 5. Ordering Guide

Ordering Part Number (OPN)	Description
Si830x4BF-KIT	Si830x4BF 4 Channel Smart Switch Evaluation Kit