

Si86XX ISOLINEAR USER'S GUIDE

1. Introduction

The ISOLinear reference design modulates the incoming analog signal, transmits the resulting digital signal through the Si86xx digital isolator, and filters the resulting output-side data to reconstruct the analog input signal. Key applications include: isolation amplifier for sensors, ground loop elimination, level shifting, and motor control. The ISOLinear reference design offers the user an alternative to expensive analog isolation amplifiers, with the added benefits of competitive performance and greater economy and user-flexibility. This reference design contains three different cost/performance-optimized analog isolation circuits.

The heart of the ISOLinear reference design is the Si86xx digital isolator. The Si86xx is a family of high-performance, CMOS-based galvanic isolators designed for industrial, commercial, and medical isolation applications. With isolation ratings of up to 5 kVrms, these products are available in various channel counts (1/2/3/4/5/6), speeds up to 150 Mbps, and multiple packaging options, including wide-body SOIC-16, narrow body SOIC-16, QSOP-16, and SOIC-8.

2. Kit Contents

The Si86xxIsoLin evaluation kit (Si86xxIsoLin-Kit) contains the following:

- Si86xxIsoLin evaluation board (Si86xxIsoLin-EB) featuring multiple Si8630 150 Mbps digital isolators in a wide-body SOIC-16 package.

2.1. Hardware Overview

The Si86xxIsoLin reference design board contains three different analog isolation circuits with performance summarized in Table 1.

Table 1. Performance Summary

Type	Input Range (V)	Bandwidth (kHz)	Resolution (Bits)	THD (% Input)	Gain (V/V)	Input impedance (kΩ)	Output Current (mA)
Circuit 1	±1	100	12	0.025	1.04	22	100
Circuit 2	±1	500	10	0.35	0.9	1.2	100
Circuit 3	±0.5	250	9	0.2	0.9	1.2	100

A photo of the Si86xxIsoLin reference design board is shown in Figure 1, and a top-level hardware block diagram is shown in Figure 2.

Si86xxIsoLin-UG

As shown in Figure 1, each circuit has analog input and output BNC connectors. Standard banana connectors are used for applying power to the evaluation board, and each circuit can be individually powered using proper jumper settings.

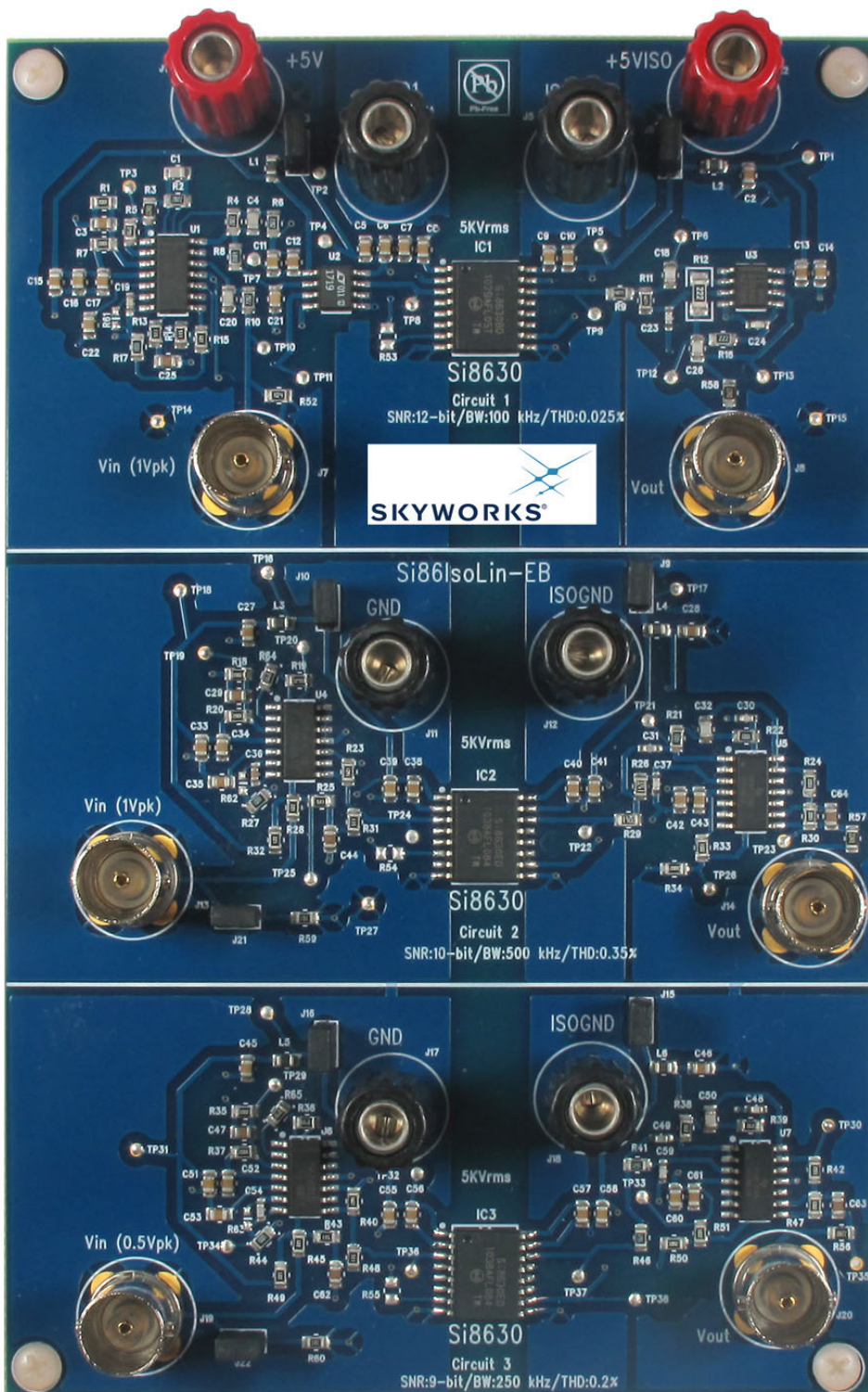

Figure 1. Reference Design Board Photo

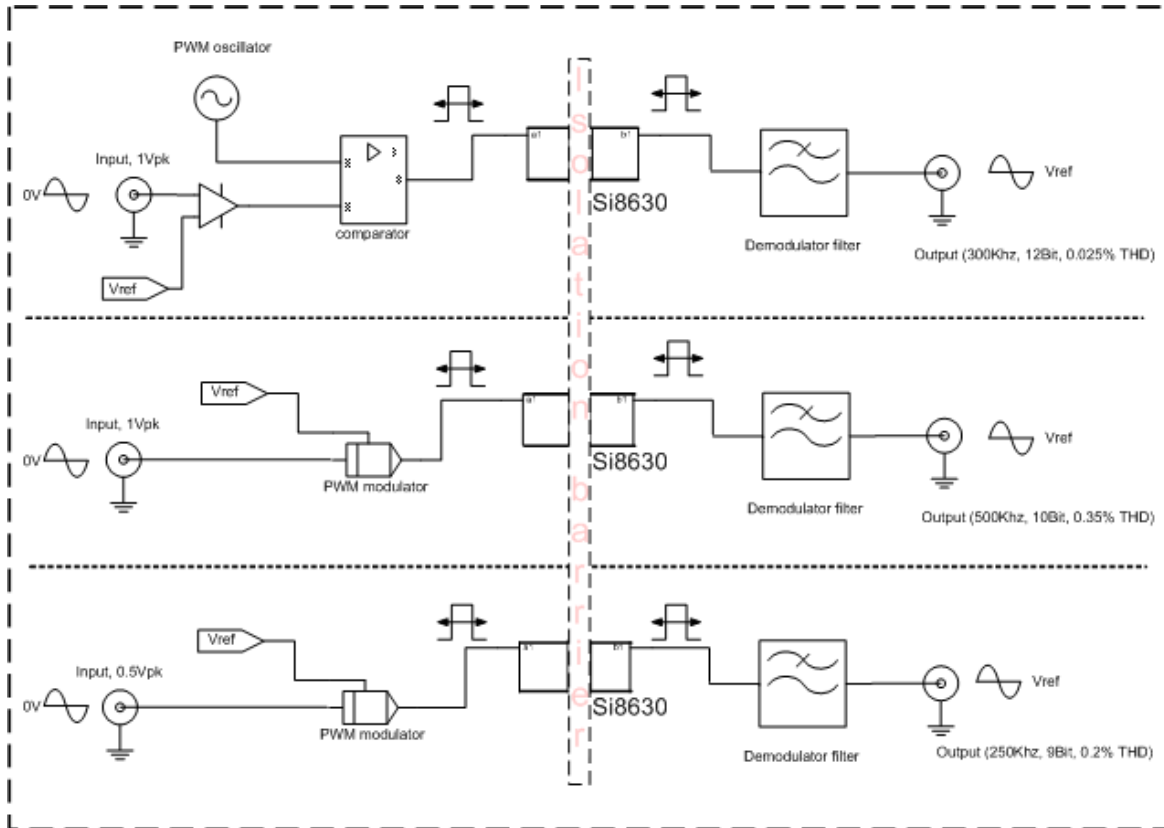

Figure 2. Top-Level Hardware Overview

3. Required Equipment

The following items are required equipment:

- Two dc power supplies (isolated)
- Two red and black banana-to-banana cables
- Two standard coaxial cables with male connectors on each end
- Si86xxIsoLin evaluation board (board under test)
- Si86xxIsoLin User's Guide (this document)

3.1. Optional Equipment

The user can test the functionality of a standalone EVB using the following equipment:

- One four-channel oscilloscope (ex. TDS784A)
- Spectrum/FFT Analyzer (ex. SR770)
- Signal generator (ex. Agilent 33220A).

4. Hardware Overview and Demo

The Si86xxIsoLin evaluation board operates from 4.25 to 5.5 V. Each isolated analog circuit is powered up by jumper settings as shown in Figures 3, 4, and 5 (Circuits 1, 2, and 3, respectively).

Refer to Figure 3:

J1, J4	Connector for +5 V bus (J1) and GND1(J4) plane
J2,J5	Connector for +5 VISO bus (J2) and ISOGND1(J5) plane
J3,J6	Header 2x1, Power supply select for Circuit 1
J7,J8	BNC connector for input (J7) and output (J8) for Circuit 1

Refer to Figure 4:

J11, J12	Connector for GND2 (J11) and ISOGND2 (J12)
J10,J9	Header 2x1, Power supply select for Circuit 2
J13,J14	BNC connector for input (J13) and output (J14) for Circuit 2

Refer to Figure 5:

J15,J16	Header 2x1, Power supply select for Circuit 3
J17,J18	Connector for GND2 (J11) and ISOGND2 (J12)
J19, J20	BNC connector for input (J19) and output (J20) for Circuit 3

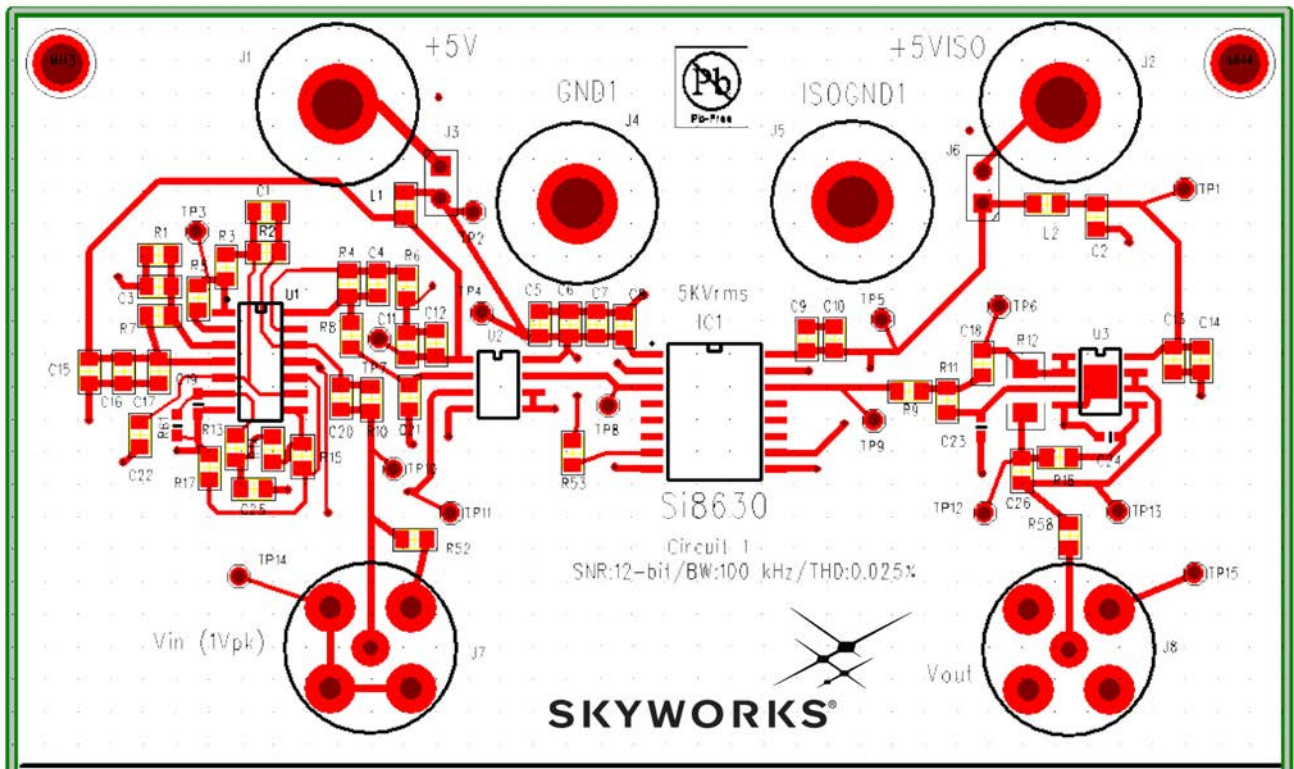

Figure 3. Circuit 1 Interface

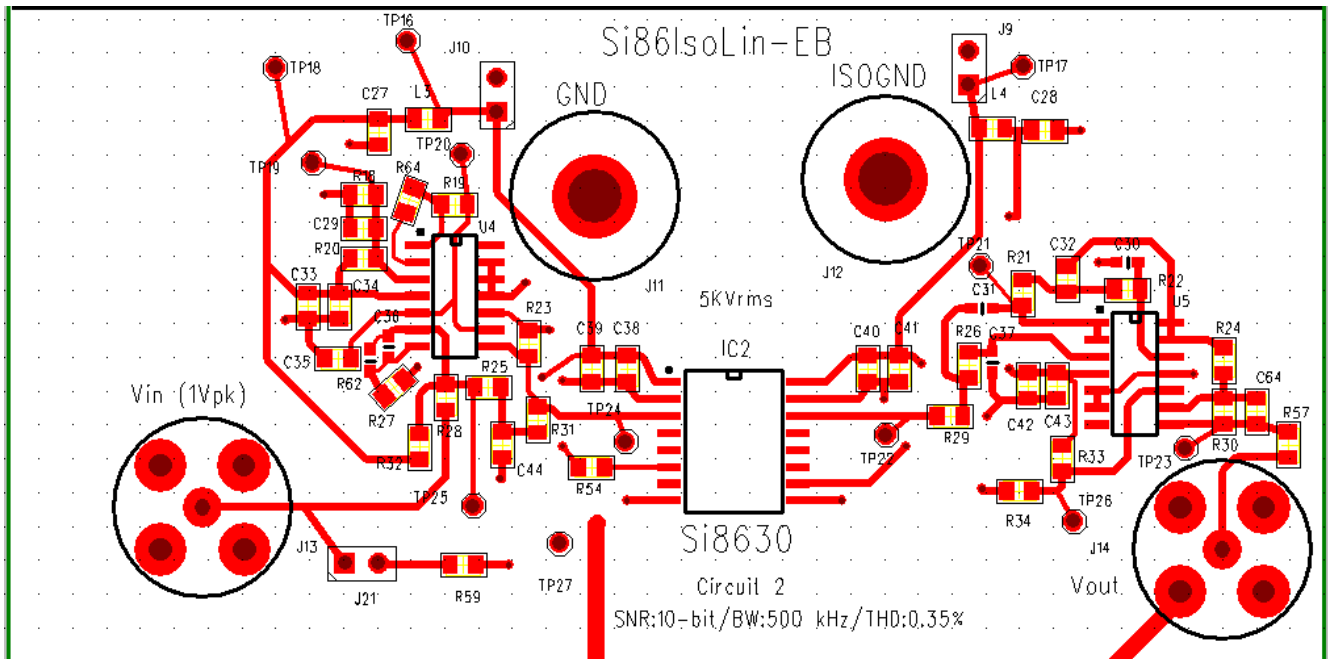

Figure 4. Circuit 2 Interface

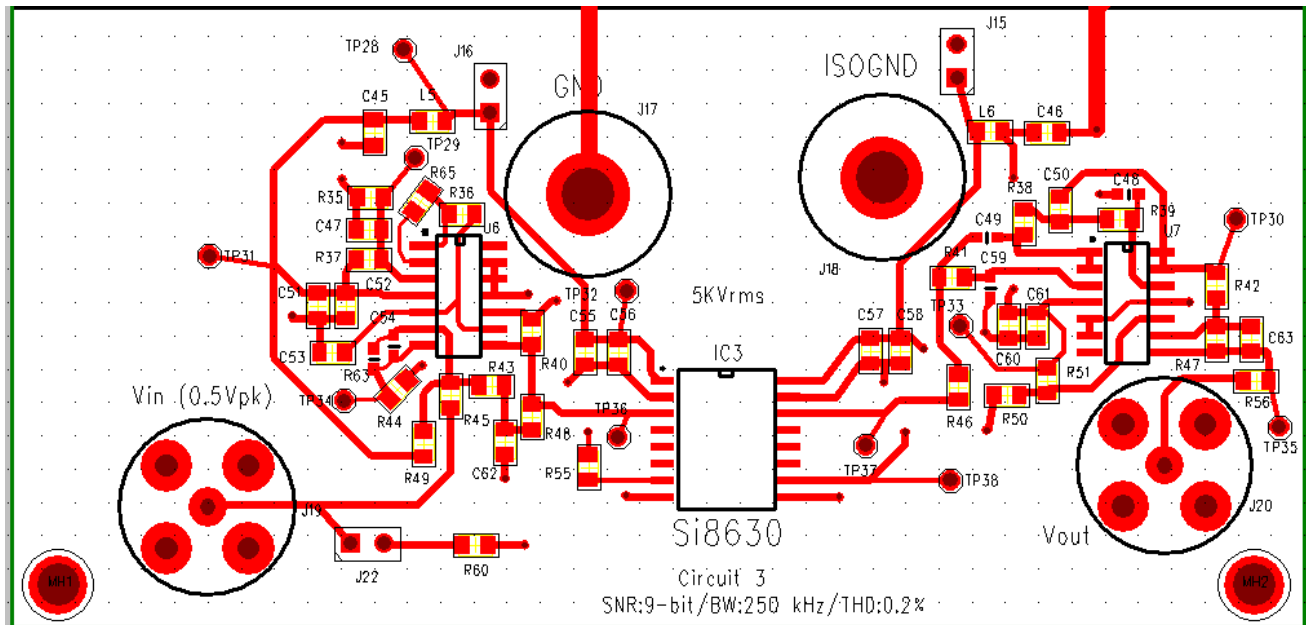

Figure 5. Circuit 3 Interface

4.1. Common Board Setup

Perform the following steps for a common board setup:

1. Turn on the dc power supplies, and set the output voltage to 5.0 V (500 mA current limit).
2. Connect the red banana cables to each positive output of the power supply and the black banana cable to the respective negative or 0 V output.
3. Connect the other end of one of the red banana cables to J1 (+5 V) and the other end of the second red banana cable to J2 (+5 VISO).

It is highly recommended to use a buffer between the signal source and evaluation board as shown in Figure 6 to avoid any loading issues.

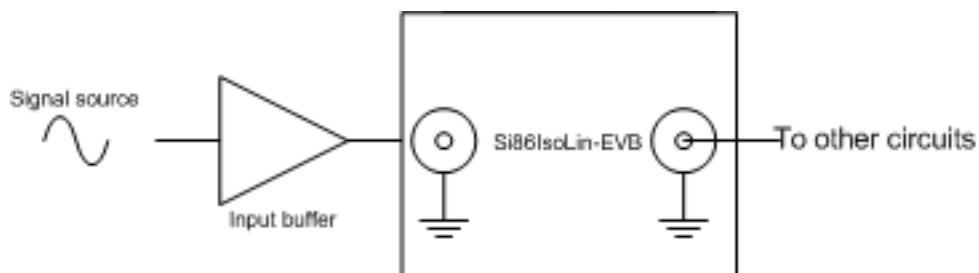

Figure 6. Recommended Input Buffer

4.2. Circuit 1 Setup

Perform the following steps for Circuit 1 setup:

1. Connect the other end of the black banana cable to J4(GND1) and J5 (ISOGND1).
2. Shunt jumpers J3 and J6 to apply power to the circuit.
3. Turn ON the dc power supply.
4. Connect one end of the coaxial cable to J7 (Vin) and the other end to an analog signal source (if buffer is used, connect the other end to the output of the buffer).
5. Connect one end of the other coaxial cable to J8 (Vout) and the other end to the circuit following. The output may be connected to the oscilloscope (1 M Ω impedance) for initial verification.
6. Figures 7–11 shows various analog signal response of Circuit1.
7. The board under test is ready for transferring signal across the isolation barrier.
8. Make sure the amplitude of the analog source $\leq \pm 1$ Vpk and frequency ≤ 100 kHz.

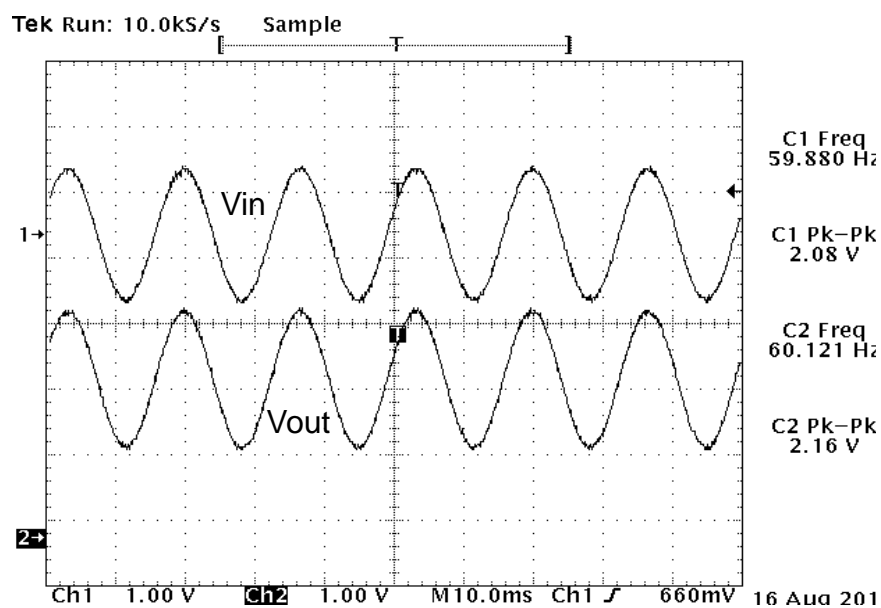

Figure 7. Circuit 1 Waveform (Vin = 2 Vpp, 60 Hz)

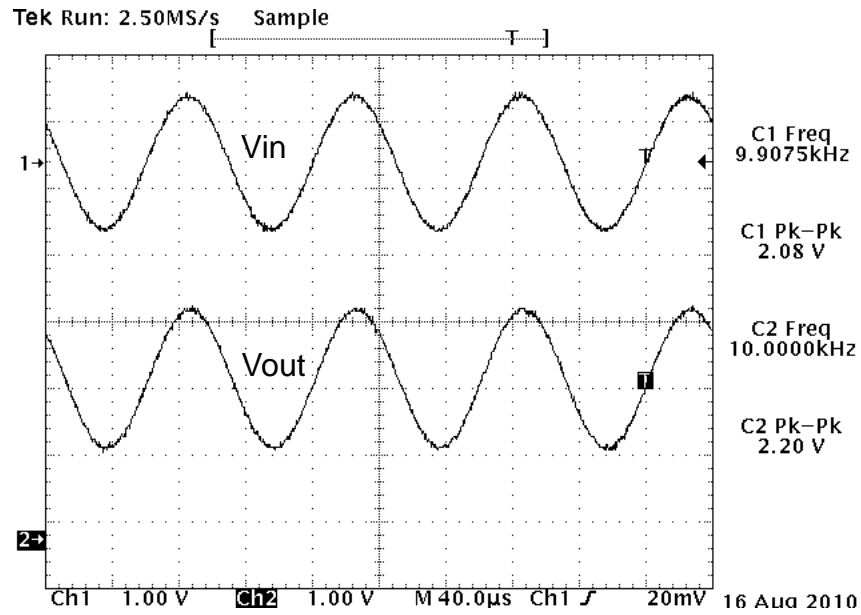

Figure 8. Circuit 1 Waveform ($V_{in} = 2 V_{pp}$, 10 kHz)

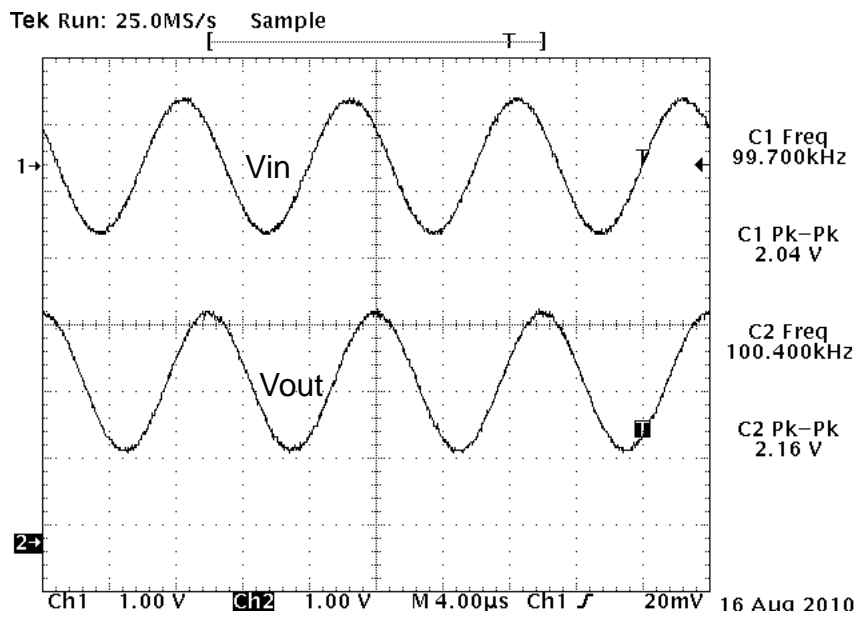

Figure 9. Circuit 1 Waveform ($V_{in} = 2 V_{pp}$, 100 kHz)

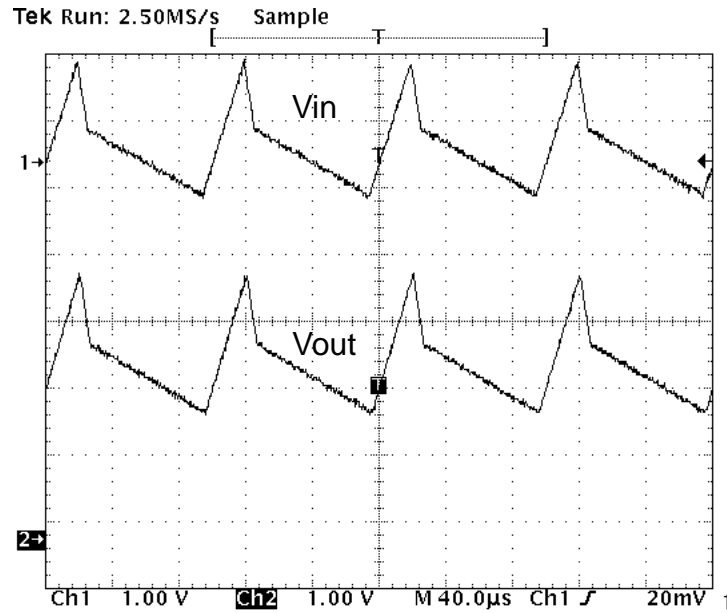

Figure 10. Circuit 1 Arbitrary (10 kHz) Waveform Response

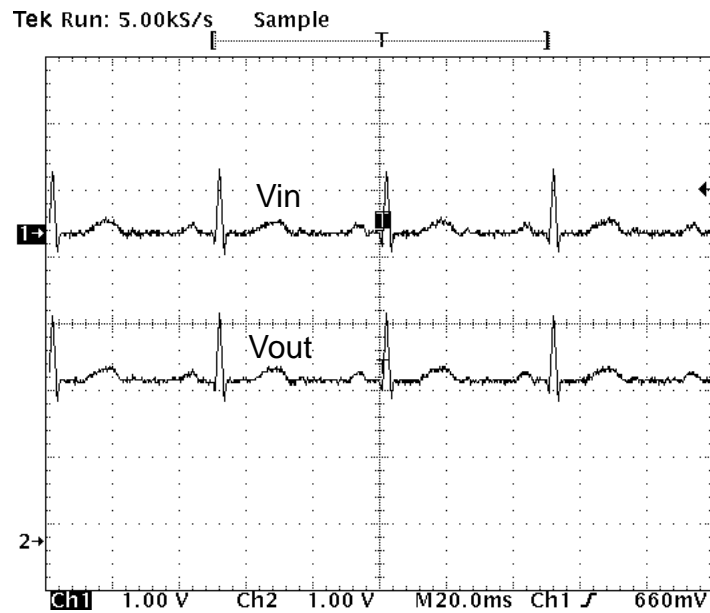

Figure 11. Circuit 1 Cardiac (20 Hz) Waveform Response

Si86xxIsoLin-UG

4.3. Circuit 2 Setup

1. Turn off the dc power supplies if they are not already turned off.
2. Shunt jumpers J9 and J10 to apply power to the circuit.
3. Move the other end of the black banana cable to J11(GND) and J12 (ISOGND).
4. Turn ON the dc power supply.
5. Connect one end of the coaxial cable to J13 (Vin) and the other end to an analog signal source (if buffer is used, connect the other end to the output of the buffer).
6. Connect one end of the other coaxial cable to J14 (Vout) and the other end to the circuit following. The output may be connected to the oscilloscope (1 M Ω impedance) for initial verification.
7. Figures 12–16 show various analog signal responses of Circuit 2.
8. The board under test is ready for transferring signal across the isolation barrier.
9. Make sure the amplitude of the analog source $\leq \pm 1\text{Vpk}$ and frequency $\leq 500\text{ kHz}$.

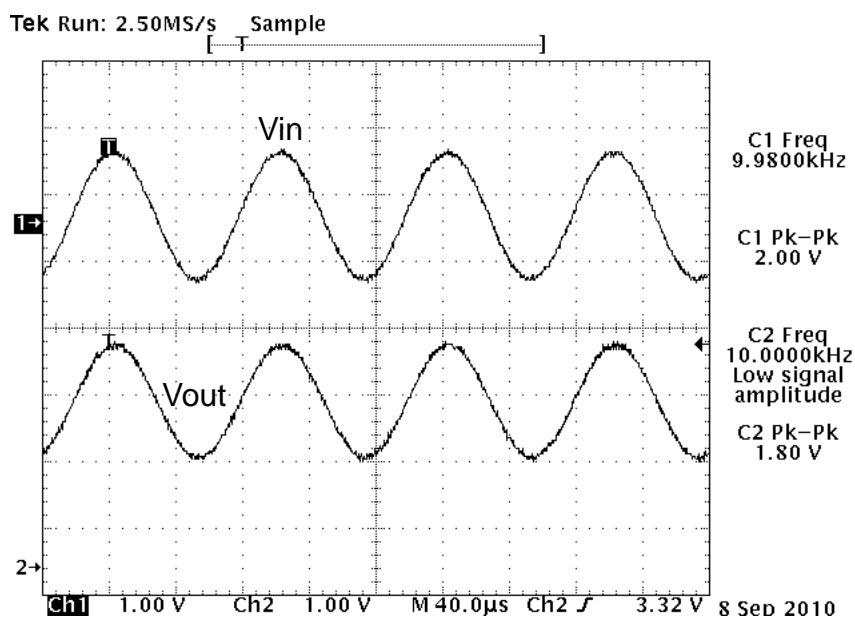

Figure 12. Circuit 2 waveform ($V_{in} = 2\text{ Vpp}$, 10 kHz)

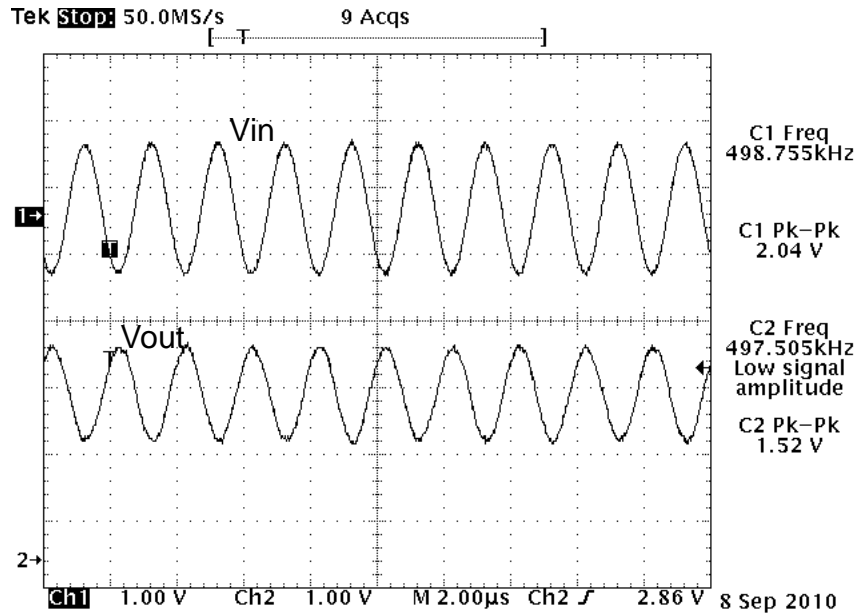

Figure 13. Circuit 2 Waveform ($V_{in} = 2 V_{pp}$, 500 kHz (-3 dB BW))

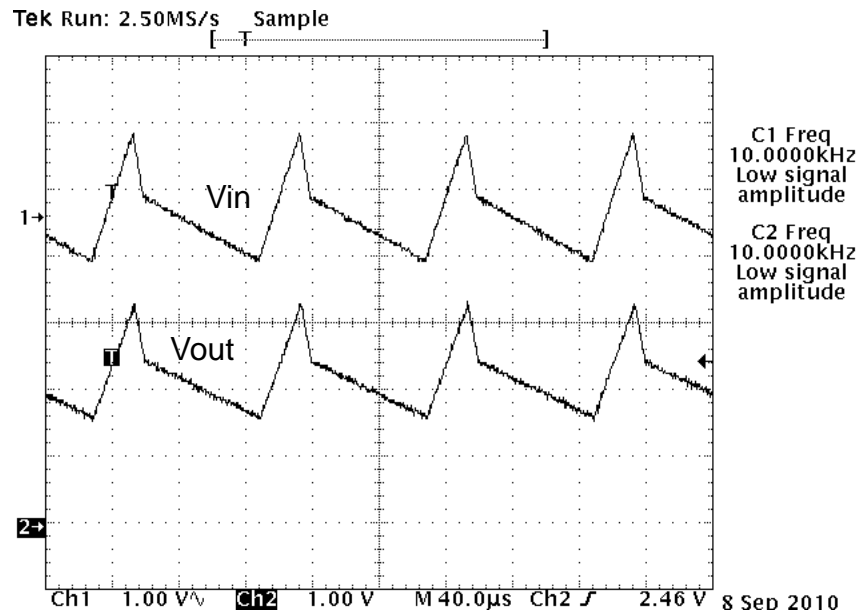

Figure 14. Circuit 2 Arbitrary (10 kHz) Waveform Response

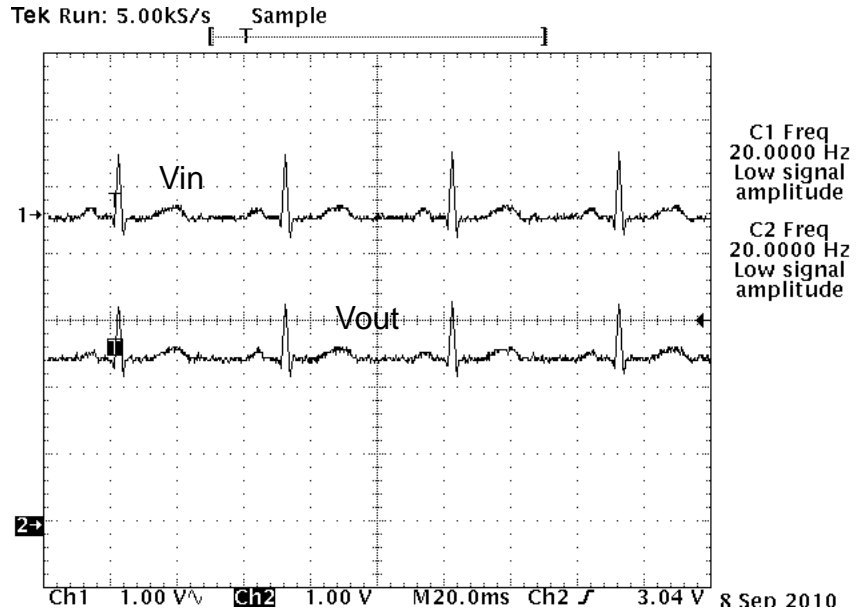

Figure 15. Circuit 2 Cardiac (20 Hz) Waveform Response

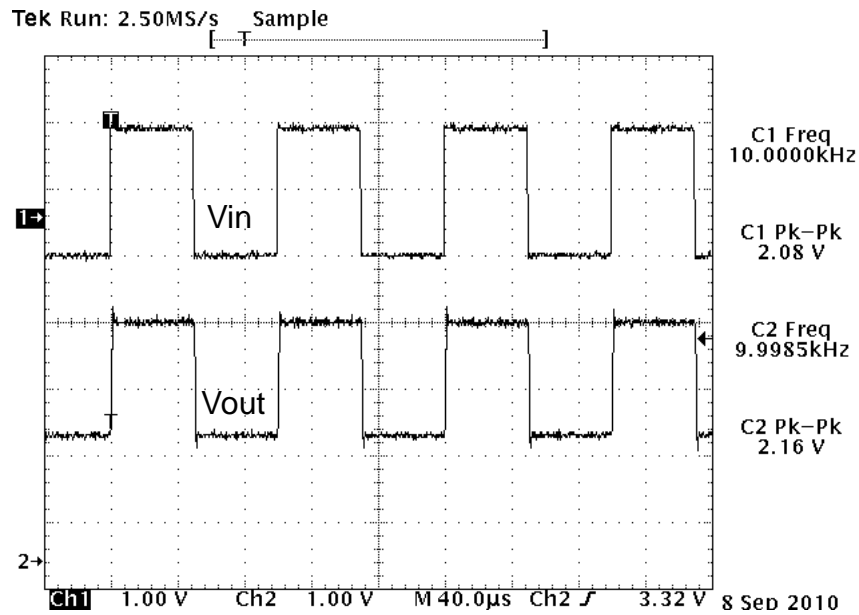

Figure 16. Circuit 2 Pulse Train (10 kHz) Response

4.4. Circuit 3 Setup

1. Turn off the dc power supplies, if they are not turned off already.
2. Shunt jumpers J16 and J15 to apply power to the circuit.
3. Move the other end of the black banana cable to J17(GND) and J18 (ISO GND)
4. Turn ON the dc power supply.
5. Connect one end of the coaxial cable to J19 (Vin) and the other end to an analog signal source (if buffer is used, connect the other end to the output of the buffer).
6. Connect one end of the other coaxial cable to J20 (Vout) and the other end to the circuit following. The output may be connected to the oscilloscope (1 M Ω impedance) for initial verification.
7. Figures 17–21 show the various analog signal responses of Circuit 3.
8. The board under test is ready to transfer a signal across the isolation barrier.
9. Ensure that the amplitude of the analog source $\leq \pm 0.5$ Vpk and frequency ≤ 250 kHz

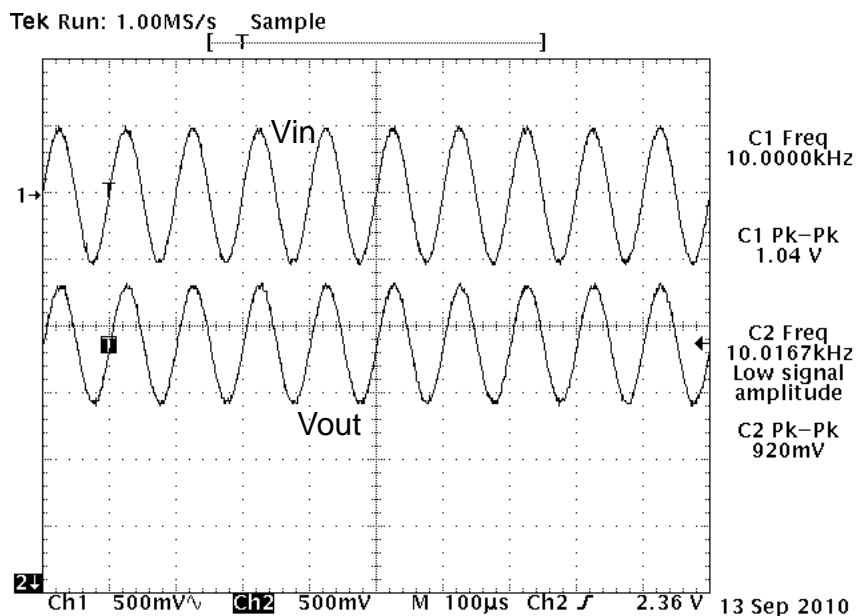

Figure 17. Circuit 3 Waveform (Vin = 1Vpp, 10 kHz)

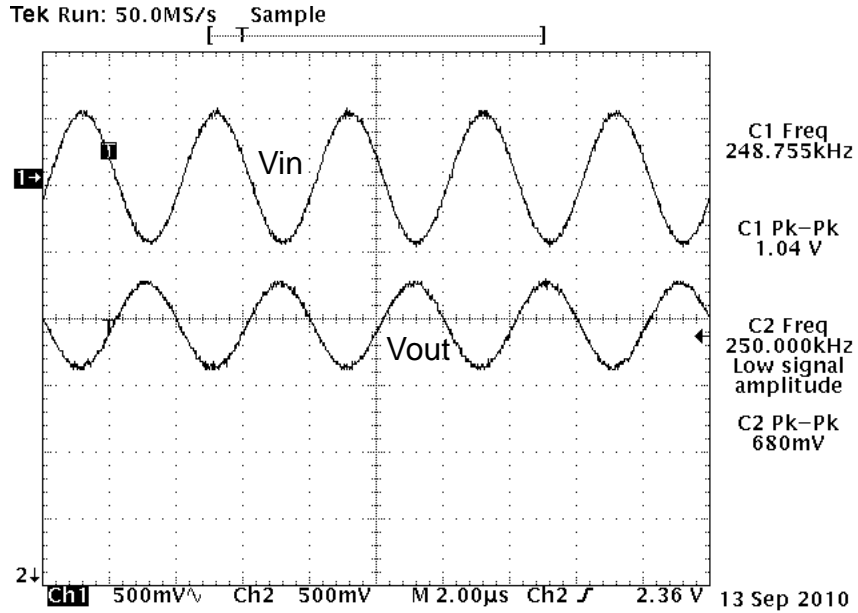

Figure 18. Circuit 3 Waveform ($V_{in} = 1 V_{pp}$, 250 kHz (3 dB BW))

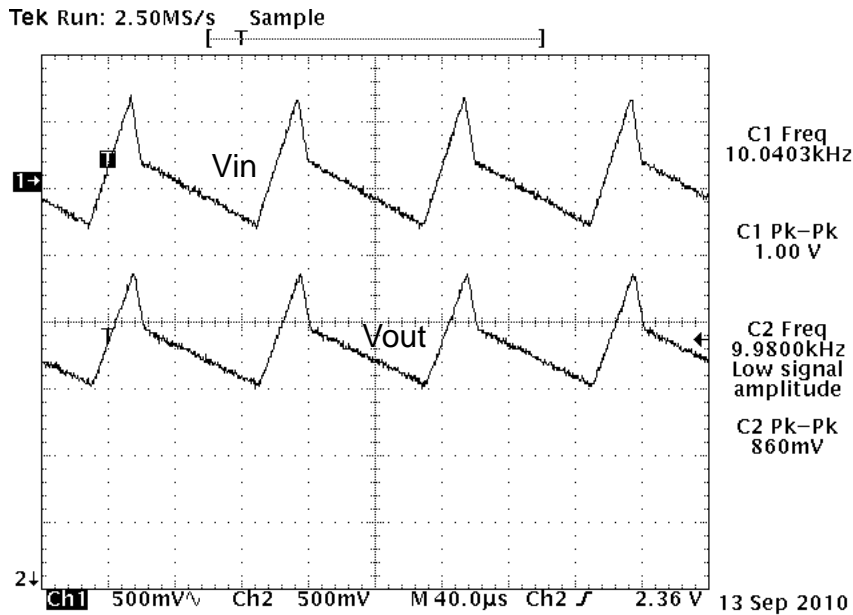

Figure 19. Circuit 3 Arbitrary (10 kHz) Waveform Response

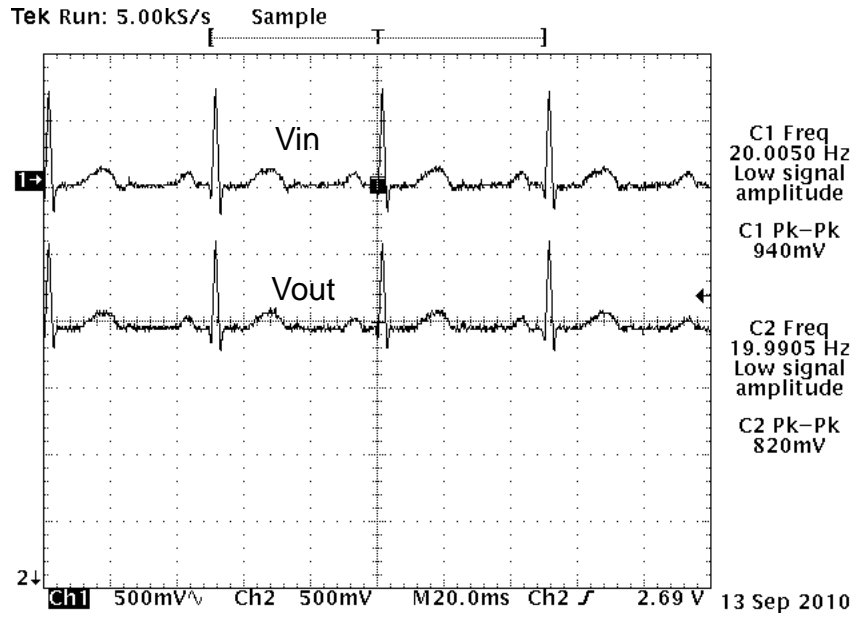

Figure 20. Circuit 3 Cardiac (20 Hz) Waveform Response

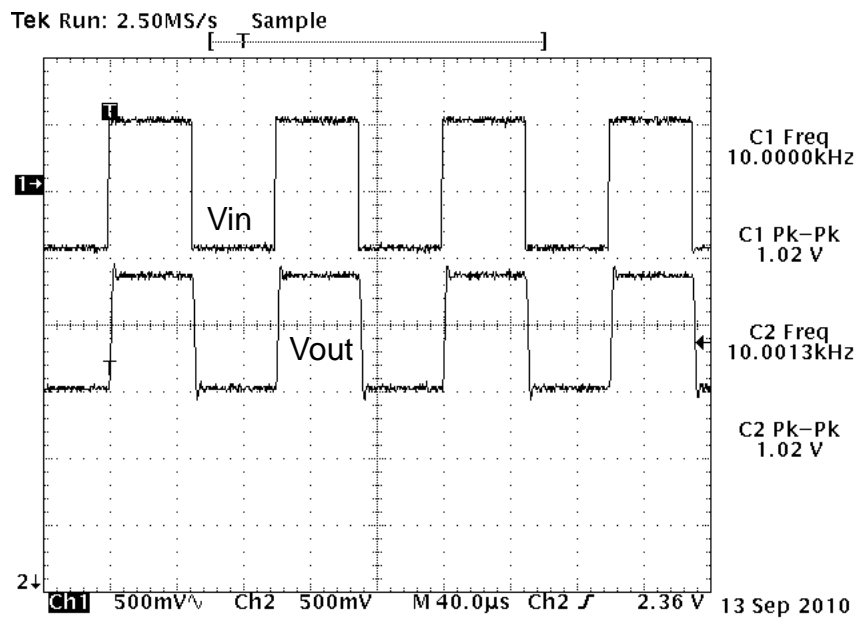

Figure 21. Circuit 3 Pulse Train (10 kHz) Response

5. Schematics

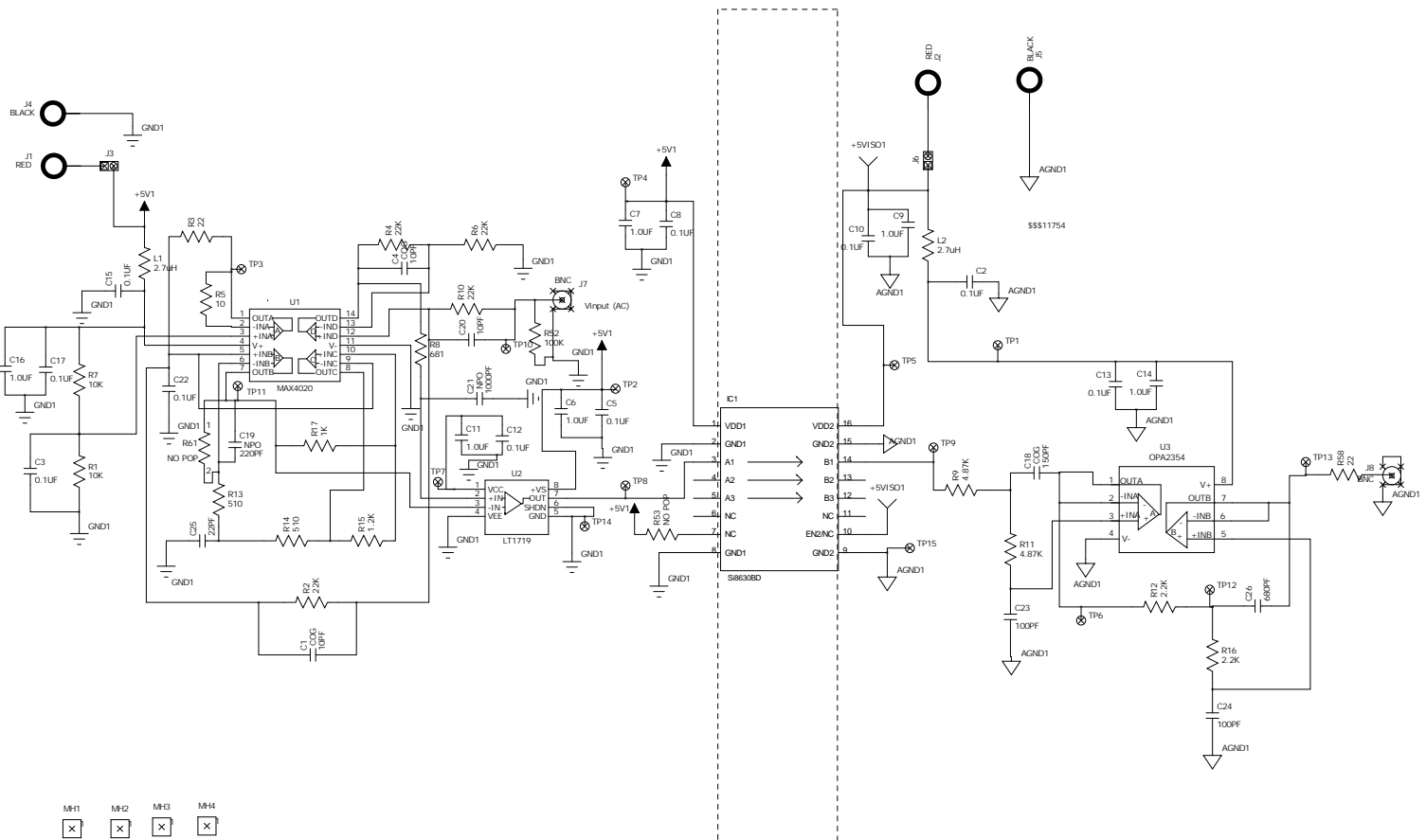

Figure 22. Circuit 1 Schematic

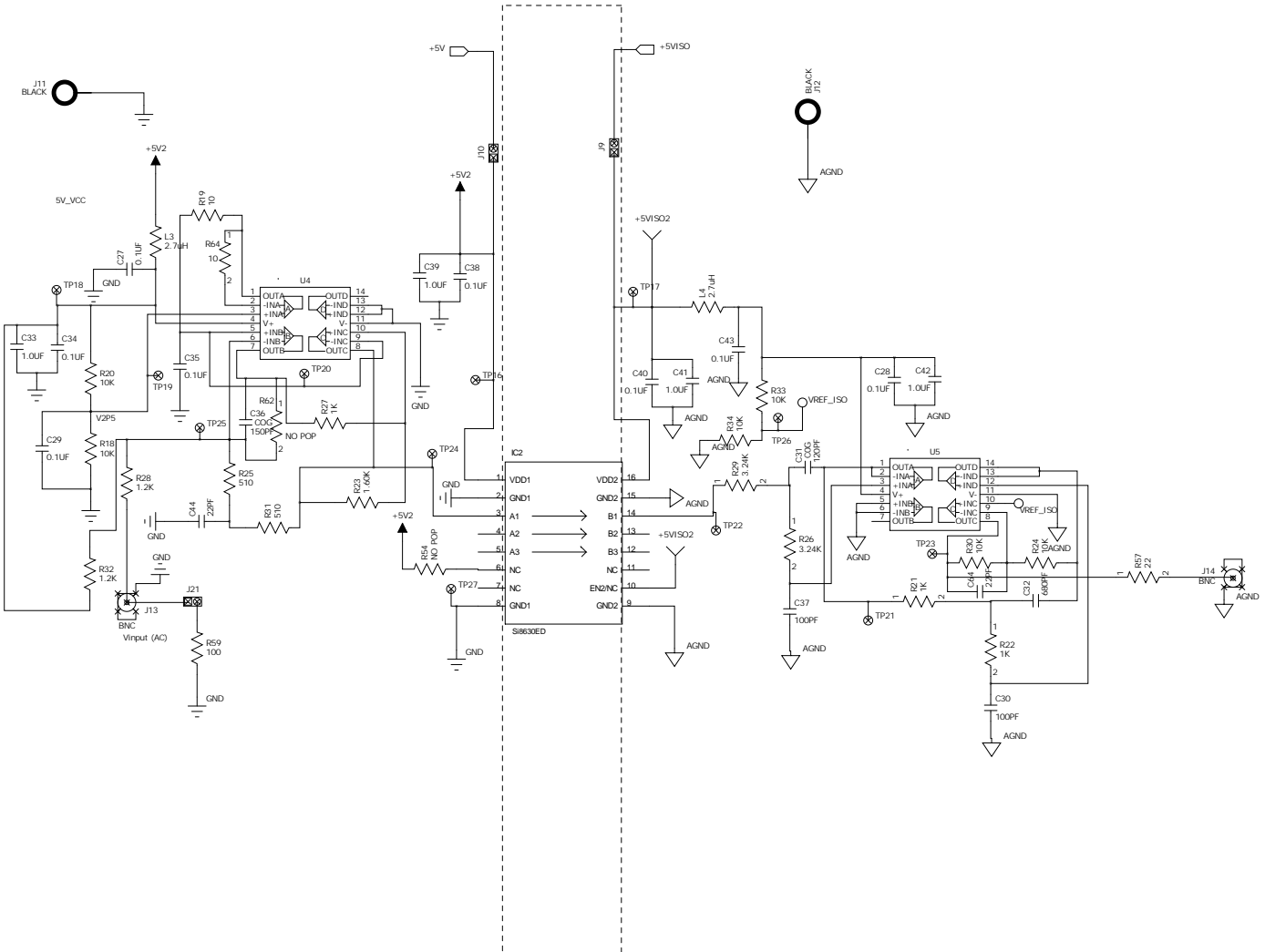

Figure 23. Circuit 2 Schematic

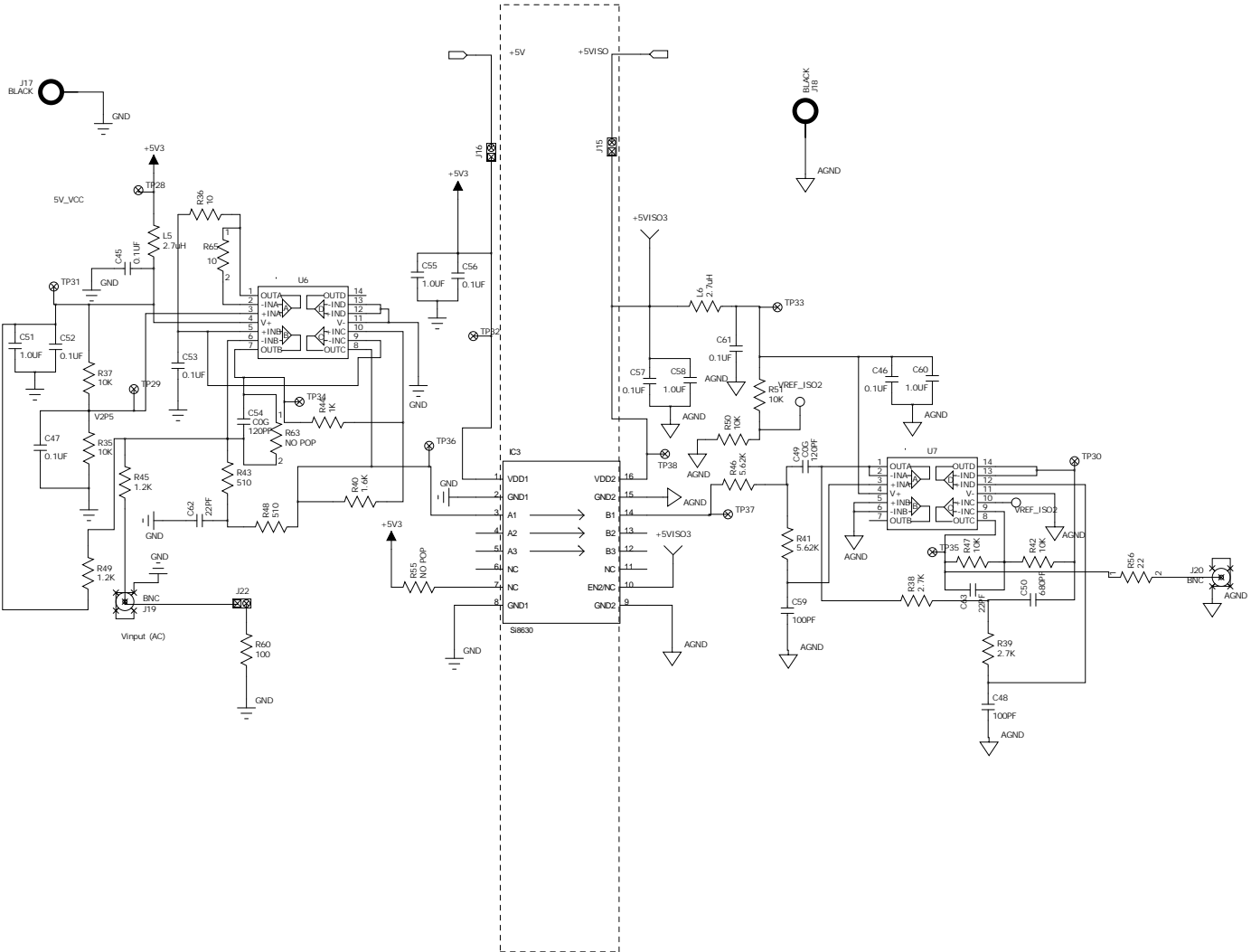

Figure 24. Circuit 3 Schematic

6. Bill of Materials

Table 2. Si86xx IsoLinear EVB Bill of Materials

Item	Qty	Ref	Part Name	Mfr	Description
1	2	J1-2	111-0702-001-ND	Digikey	CONN, POST BINDING INSULATED, RED, RoHS
2	6	J4-5, J11-12, J17-18	111-0703-001-ND	Digikey	CONN, POST BINDING INSULATED, BLACK, RoHS
3	4	MH1-4	1902EK-ND/H546	Digikey	STAND OFF WITH SCREW, RoHS
4	2	U5 U7	296-12643-2-ND	Digikey	IC OP AMP R-R IN/OUT QUAD 14SOIC
5	1	U3	296-13784-5-ND	Digikey	IC OP AMP R-R IN/OUT DUAL 8 SOIC W/PWRPAD
6	1	C21	311-1122-1-ND	Digikey	CAP CERAMIC, 1000 pF, NPO, 0805, 50 V, $\pm 5\%$, OR EQ, RoHS
7	26	C2-3, C5, C8, C10, C12-13, C15, C17, C22, C27-29, C34-35, C38, C40, C43, C45-47, C52-53, C56-57, C61	311-1140-2-ND	Digikey	CAP, 0.1 μ F, X7R, CERAMIC, 50 V, 0805, $\pm 10\%$, OR EQ, RoHS
8	1	R16	311-2.2KARCT-ND	Digikey	RES, 2.2 k Ω , SMT, 0805, 1/8 W, $\pm 5\%$, OR EQ, RoHS
9	1	R12	311-2.2KARCT-ND	Digikey	RES, 2.2 k Ω , SMT, 0805, 1/8 W, $\pm 5\%$, OR EQ, RoHS
10	2	R38-39	311-2.7KARCT-ND	Digikey	RES 2.7 k Ω , SMT, 0805, 1/8 W, $\pm 5\%$, OR EQ
11	4	R2, R4, R6, R10	311-22.0KCRCT-ND	Digikey	RES 22 k Ω , SMT, 0805, 1/8 W, $\pm 1\%$, OR EQ, RoHS
12	4	R3, R56-58	311-22BCT-ND	Digikey	RES 22 Ω , SMT, 0805, 1/8 W, $\pm 0.5\%$, OR EQ, RoHS
13	1	R8	311-681CRCT-ND	Digikey	RES, 681 Ω , SMT, 0805, 1/8 W, $\pm 1\%$, OR EQ, RoHS
14	2	C1 C4	399-1108-1-ND	Digikey	CAP, 10 pF, COG, CERAMIC, 50V, 0805, $\pm 5\%$, OREQ, RoHS
15	1	C20	399-1108-1-ND	Digikey	CAP, 10 pF, COG, CERAMIC, 50V, 0805, $\pm 5\%$, OREQ, RoHS
16	6	L1-6	445-1052-6-ND	Digikey	Inductor, 2.7 μ H, SMT, 0805, OR EQ, RoHS

Si86xxIsoLin-UG

Table 2. Si86xx IsoLinear EVB Bill of Materials (Continued)

Item	Qty	Ref	Part Name	Mfr	Description
17	2	C31 C49	445-1282-1-ND	Digikey	CAP, 120 pF, C0G, CERAMIC, 0603, 50 V, $\pm 5\%$, OR EQ, RoHS
18	1	C54	445-1282-2-ND	Digikey	CAP, 120 pF, C0G, CERAMIC, 0603, 50 V, $\pm 5\%$, OR EQ, RoHS
19	6	C23–24, C30, C37, C48, C59	478-1175-1-ND	Digikey	CAP, 100 pF, C0G, CERAMIC, 0603, 50 V, $\pm 5\%$, OR EQ, RoHS
20	1	C19	478-3719-1-ND	Digikey	CAP CERAMIC, 220PF, C0G/NPO, 0603, 50 V, $\pm 1\%$, OR EQ, RoHS
21	1	C26	478-6033-1-ND	Digikey	CAP CERAMIC, 680PF 50 V NPO 0603 OR EQ, RoHS.
22	2	C32 C50	478-6033-6-ND	Digikey	CAP CERAMIC, 680PF, NPO, 0603, 50 V, $\pm 1\%$, OR EQ, RoHS
23	6	J7–8, J13–14, J19–20	A97581-ND	Digikey	CONN, JACK BNC STR, 50 Ω , PCB, OR EQ, RoHS
24	1	U2	LT1719CS8#PBF-ND	Digikey	LT1719CS8 IC COMP R-R I/O SGL
25	2	U1 U4	MAX4020ESD+-ND	Maxim	IC OP AMP R-R OUT QUAD 14SOIC
26	1	U6	MAX4020ESD+-ND		
27	3	R61–63	NO POP	Digikey	RES, NO POP, SMT, 0603, OR EQ, RoHS
28	3	R53-55	NO POP	Digikey	RES, NO POP, SMT, 0805, OR EQ, RoHS
29	38	TP1–38	NO POP	Digikey	TEST POINT, PC COMPACT, NO POP, OR EQ, RoHS
30	5	R17, R21–22, R27, R44	P1.00KCTR-ND	Digikey	RES, 1 k Ω , SMT, 0805, 1/8 W, $\pm 1\%$, OR EQ, RoHS
31	1	R15	P1.2KATR-ND	Digikey	RES, 1.2K OHM, SMT, 0805, 1/8 W, $\pm 5\%$, OR EQ, RoHS.
32	1	R40	P1.6KATR-ND	Digikey	RES, 1.6 k Ω , SMT, 0805, 1/8 W, $\pm 5\%$, OR EQ, RoHS
33	1	R23	P1.6KATR-ND	Digikey	RES 1.60 k Ω , SMT, 0805, 1/8 W, $\pm 1\%$, OR EQ, RoHS
34	5	R5, R19, R36, R64–65	P10.0CCT-ND	Digikey	RES, 10 Ω , SMT, 0805, 1/8 W, $\pm 1\%$, OR EQ, RoHS

Table 2. Si86xx IsoLinear EVB Bill of Materials (Continued)

Item	Qty	Ref	Part Name	Mfr	Description
35	14	R1, R7, R18, R20, R24, R30, R33–35, R37, R42, R47, R50–51	P10.0KCCT-ND	Digikey	RES, 10.0 kΩ, SMT, 0805, 1/8 W, ±1%, OR EQ, RoHS
36	2	R59-60	P100ACT-ND	Digikey	RES, 100 Ω, SMT, 0805, 1/8 W, ±5%, OR EQ, RoHS
37	1	R52	P100KACT-ND	Digikey	RES, 100 kΩ, SMT, 0805, 1/8 W, ±5%, OR EQ, RoHS
38	2	R9 R11	P4.87KCCT-ND	Digikey	RES, 4.87 kΩ, SMT, 0805, 1/8 W, ±1%, OR EQ, RoHS
39	2	R41 R46	P5.62KCCT-ND	Digikey	RES, 5.62 kΩ, SMT, 0805, 1/8 W, ±1%, OR EQ, RoHS
40	6	R13–14, R25, R31, R43, R48	P510ACT-ND	Digikey	RES, 510 Ω, SMT, 0805, 1/8 W, ±5%, OR EQ, RoHS
41	1	C18	PCC151ACVCT-ND	Digikey	CAP, 150 pF, COG, 0603, 50 V, ±5%, OR EQ, RoHS
42	1	C36	PCC151ACVCT-ND	Digikey	CAP, 150 pF, COG, 0603, 50 V, ±5%, OR EQ, RoHS
43	5	C25, C44	PCC220CNCT-ND	Digikey	CAP CERAMIC, 22 pF, NP0, 0805, 50 V, ±5%, OR EQ, RoHS
44	14	C6–7, C9, C11, C14, C16, C33, C39, C41–42, C51, C55, C58, C60	PCC2249CT-ND	Digikey	CAP 1.0UF, X5R, CERAMIC, 0805, 16 V, ±10%, OR EQ, RoHS
45	2	R26, R29	RT0805DRD073K2	Digikey	RES, 3.24 kΩ, SMT, 0805, 1/8 W, ±0.5%, OR EQ, RoHS
46	8	J3, J6, J9–10, J15–16, J21–22	SNT-100-BK-G-ND	Samtec	JUMPER 2POS SNGL 2.54MM, 1X2, GOLD, OR EQ, RoHS
47	1	IC1	Si8630BD-A-IS	Skyworks	5 kVrms Digital Isolator, 86xx series
48	1	IC3	Si8630ED-A-IS	Skyworks	5 kVrms Digital Isolator, Si86xx series
49	1	IC2	Si8630ED-A-IS	Skyworks	5 kVrms Digital Isolator, 86xx series

Si86xxIsoLin-UG

7. Cost

Table 3. Cost Breakdown by Circuit Type

Type	Cost (\$/10kU)
Circuit 1	~ 5.0
Circuit 2	~ 4.0
Circuit 3	~ 4.0

8. Ordering Guide

Ordering Part Number	Description
SI86ISOLIN-KIT	High-performance analog isolation reference design using the Si86xx digital isolators.