

---

## Si86xxISO EVALUATION BOARD USER'S GUIDE

---

### 1. Introduction

The Si86xxISO evaluation board allows designers to evaluate Skyworks family of CMOS ultra-low-power isolators. These isolators are CMOS devices employing RF coupler technology to transmit digital information across an isolation barrier. Very high speed operation at low power levels is achieved. These products are based on Skyworks' proprietary RF isolation technology and offer shorter propagation delays, lower power consumption, improved noise immunity, smaller installed size, and more stable operation with temperature and age versus opto couplers. The Si861x/2x/3x/4x/5x/6x include up to six unidirectional isolated channels, permitting data transmission up to 150 Mbps. The Si860x isolator series consists of single-package galvanic isolation solutions for I<sup>2</sup>C, SMBus, and other digital power supply communications, including those for bus power management. For more information, refer to the respective family data sheets.

A summary of the benefits provided by the Skyworks Si86xx CMOS Digital Isolator family includes:

- Si86xx Digital Isolators
  - 5.0 kV, 3.75 kV, and 1.0 kV isolation ratings
  - UL, CSA, and VDE certifications
  - DC to 150 Mbps
  - 2.5 to 5.5 V VDD supply range
  - Fail-safe operating mode(s)
  - -40 to 125 °C temperature range
  - 10 ns max propagation delay
  - <1.5 mA/channel @ 1 Mbps
  - <1.5 ns pulse width distortion
  - Very low EMI
  - Up to 50 V/m electric field immunity
  - >1000 A/m magnetic field immunity
  - >30 kV/μs CMTI
  - 4 kV HBM ESD immunity
- Si860x I<sup>2</sup>C-Compatible Bidirectional Isolators
  - Bidirectional SDA and SCL
  - 1.7 Mbps
  - 35 mA open drain I/O
  - 3 to 5.5 V VDD supply range
- Packaging and Isolation Rating Options
  - WB SOIC-16 (5 kV)
  - NB SOIC-16 (3.75 kV)
  - NB SOIC-8 (3.75 kV)
  - QSOP-16 (1 kV)
  - RoHS compliant

# Si86xxISO-EVB UG

## 2. Kit Contents

The Si86xxISO Evaluation Kit contains the following items:

- Si86xxISO based evaluation board (Si86xxISO-EVB) shown in Figure 1.
- Si8600, Si8605, Si8621, Si8655, and Si8663 CMOS digital isolators installed on the evaluation board

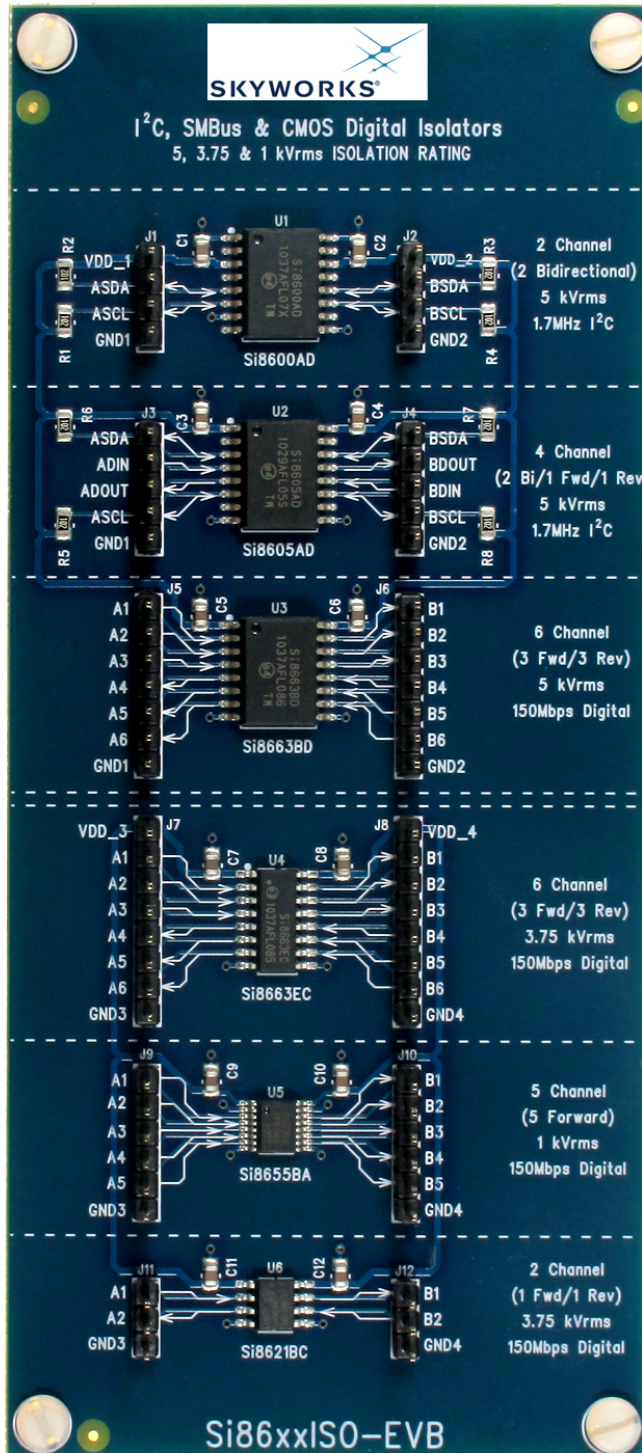

Figure 1. Si86xxISO Evaluation Board Overview

## 3. Hardware Overview and Setup

The Si86xxISO evaluation board is populated with the following isolators:

- Si8600 (2-channel I<sup>2</sup>C isolator)
- Si8605 (2-channel digital isolator, 2-channel I<sup>2</sup>C isolator)
- Si8621 (2-channel digital isolator, one forward, one reverse)
- Si8455 (5-channel digital isolator, five forward)
- Si8663 (6-channel digital isolator, three forward, three reverse)

The board is designed to be powered from two separate supplies (2.5–5.5 V, 500 mA) that power all the isolators on the board. VDD1,GND1 and VDD2,GND2 power the 5 kV isolators. VDD3,GND3 and VDD4,GND4 power the 1 and 2.5 kV isolators. Supplies as low as 2.5 V can be used. If a user wants to evaluate an isolator other than the ones populated, this can be accomplished by removing the footprint-compatible device installed on the evaluation board and replacing it with the desired isolator device. Figure 2 provides a silkscreen overview of the board.

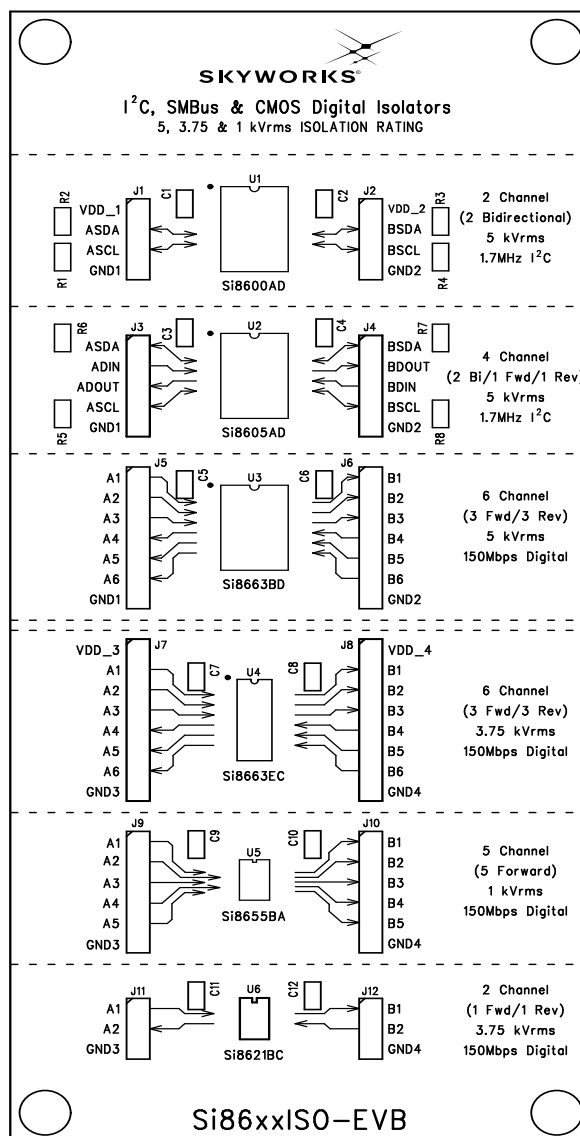

**Figure 2. Si86xxISO Evaluation Board Silkscreen**

# Si86xxISO-EVB UG

## 3.1. Digital Isolator Considerations

The Si86xxISO evaluation board (see Figure 1) provides a means of evaluating the Si861x,2x,3x,4x,5x,6x digital isolator families as well as the Si8600 isolated I<sup>2</sup>C family. After power (2.5–5 V) has been supplied to the board, connect a digital input signal (5 V<sub>peak</sub> max, with desired clock frequency up to 150 Mbps) to the desired input channel. To view the isolated channel's data transmission, connect a scope probe to the output channel of interest. There are various inputs and outputs on either side of the board depending on the device one chooses to evaluate, as indicated by the silk screen. The board can be used to measure propagation delay, pulse-width distortion, channel-channel matching, pulse-width skew, and various other parameters.

The nominal output impedance of an isolator driver channel is approximately 50 Ω, ±40%, which is a combination of the values of the on-chip series termination resistor and the channel resistance of the output driver FET. When driving loads where transmission line effects are a factor, output pins should be terminated with 50 Ω controlled impedance PCB traces.

Figure 3 illustrates the Si8621 transmitting a 500 kHz (3 V<sub>peak</sub>) signal through the Si8621. VDD1 and VDD2 were powered from 3 V. Channel 1 illustrates the input, and Channel 2 illustrates the output.

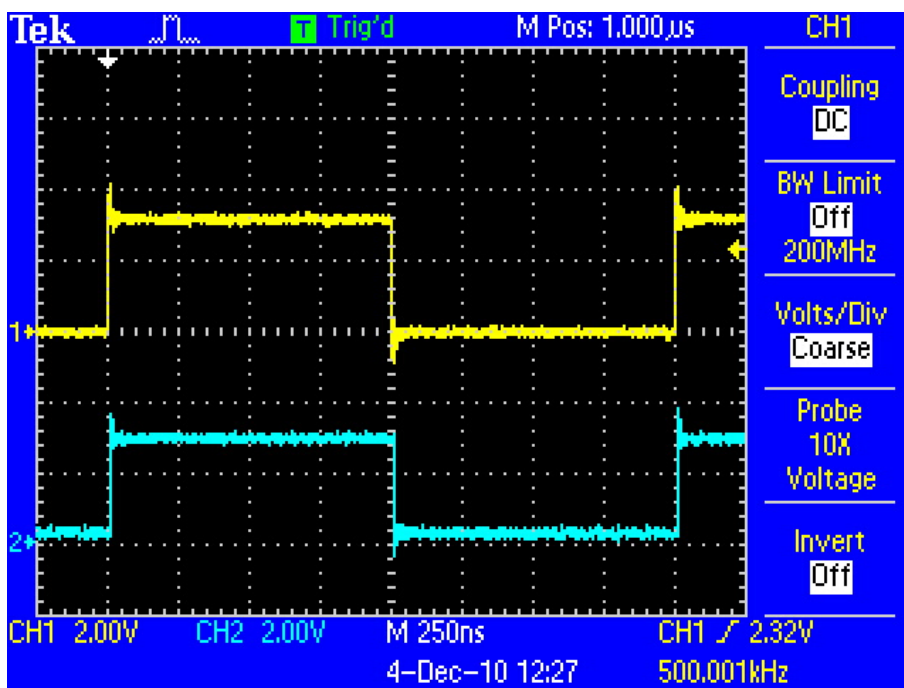

Figure 3. 500 kHz (5 V Peak) Signal

### 3.2. I<sup>2</sup>C Isolator Considerations

After power (3–5 V) has been supplied to the board, connect a digital square wave input (5 V<sub>peak</sub> max, with desired clock frequency up to 1.7 MHz) to the desired input channel. The Si8600/05 I<sup>2</sup>C isolators have 1 k $\Omega$  pull-up resistors already installed. If these resistors are redundant with another board that is being used to evaluate the Si8600/05, the user should remove the redundant pull-up resistors to accommodate adequate drive current for the test being performed.

Figure 4 illustrates Side B Pulling Up, with Side A following for the Si8600. The Si8600 was powered from 3 V on both sides with a 100 kHz input test signal.

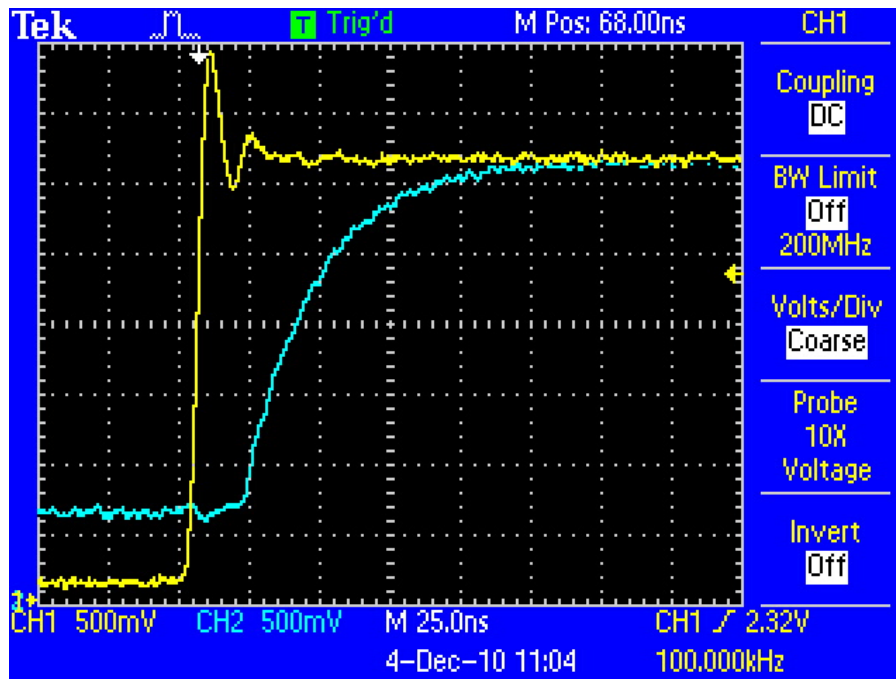

Figure 4. Side B Pulling Up, Side A Following

**Note:** The test points in front of each device have 1 mm spacing. If desired, the test points can be replaced with a 1 mm spacing terminal block to assist in evaluation.

# Si86xxISO-EVB UG

## 4. Si86xxISO Evaluation Board Schematics

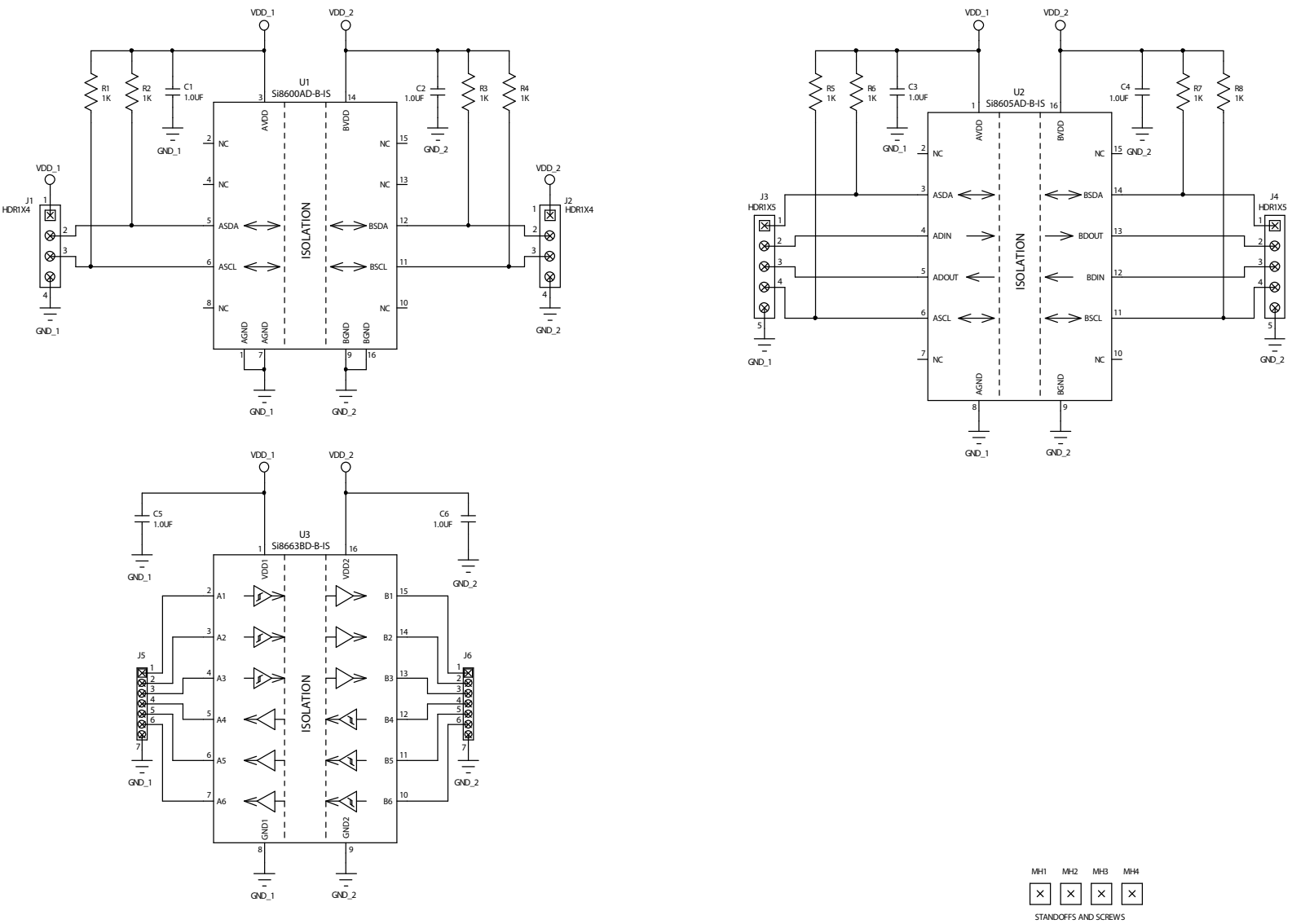
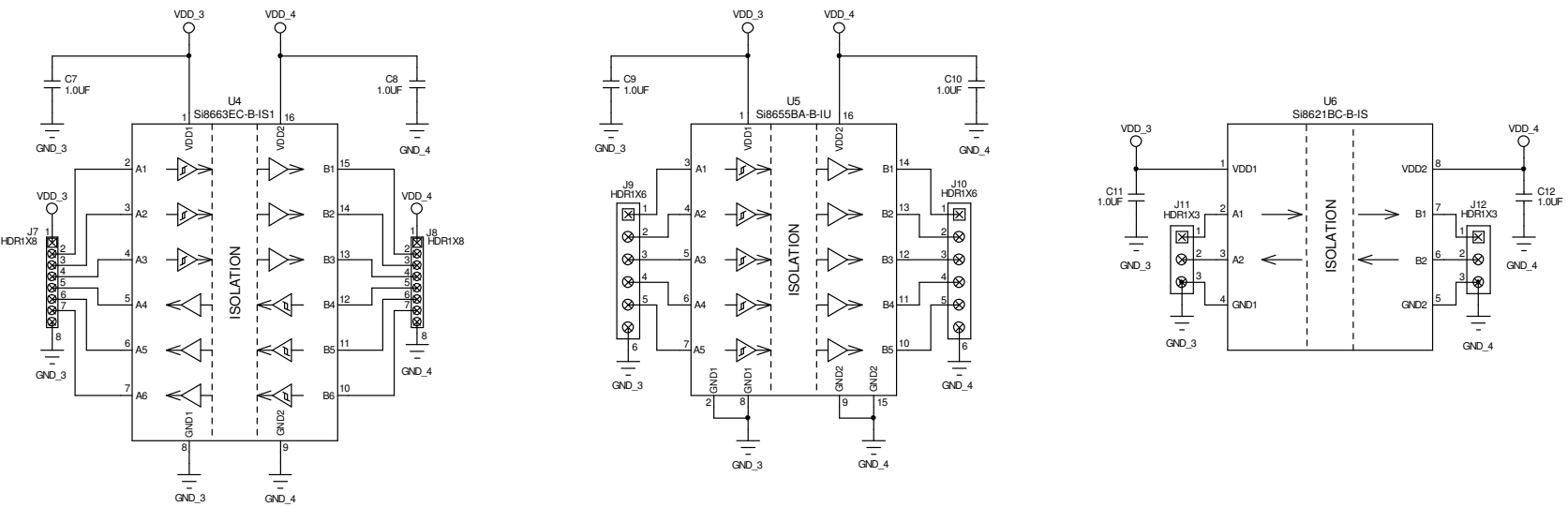

Figure 5. Si86xxISO Evaluation Board Schematic (1 of 2)



**Figure 6. Si86xxISO Evaluation Board Schematic (2 of 2)**

# Si86xxISO-EVB UG

## 5. Bill of Materials

Table 1. Si86xxISO Evaluation Board Bill of Materials\*

Item	Qty	Ref	Part #	Mfr	Description
1	4	MH1-4	1902AK-ND/H542-ND	Digikey	Standoff, Nylon, 4-40, 1/4" HEX x 0.250" HGT or EQ, RoHS
2	12	C1-12	PCC2249CT-ND	Digikey	Cap 1.0 $\mu$ F, X5R, Ceramic, 0805, 16 V, $\pm$ 10%, OR EQ, RoHS
3	8	R1-8	RR12P1.0KBCT-ND	Digikey	RES, 1 k $\Omega$ , SMT, 0805, 1/10 W, $\pm$ 0.1%, OR EQ, RoHS
4	2	J11-12	S1011E-03-ND	Digikey	STAKE HEADER, 1x3, 0.1" CTRS, OR EQ, RoHS
5	2	J1-2	S1011E-04-ND	Digikey	STAKE HEADER, 1x4, 0.1" CTRS, OR EQ, RoHS
6	2	J3-4	S1011E-05-ND	Digikey	STAKE HEADER, 1x5, 0.1" CTRS, OR EQ, RoHS
7	2	J9-10	S1011E-06-ND	Digikey	STAKE HEADER, 1x6, 0.1" CTRS, OR EQ, RoHS
8	2	J7-8	S2011E-08-ND	Digikey	STAKE HEADER, 1x8, 0.1" CTR, GOLD, OR EQ, RoHS
9	2	J5-6	S2011E-09-ND	Digikey	STAKE HEADER, 1x9, 0.1" CTR, GOLD, OR EQ, RoHS
10	1	U1	Si8600AD-B-IS	Skyworks	IC, I <sup>2</sup> C ISO, 2-Ch, 2 Bidirectional, 1.7 MHz, 5 kV, SOL-16, RoHS
11	1	U2	Si8605AD-B-IS	Skyworks	IC, 4-Ch I <sup>2</sup> C ISO, 2 Bidirectional, 2 Unidirectional, 1.7 MHz, 5 kV, SOL-16, RoHS
12	1	U6	Si8621BC-B-IS	Skyworks	IC, ISOpro Low-Power 2-Channel Isolator, 150 Mbps, 3.75 kV, SO-8, RoHS
13	1	U5	Si8655BA-B-IU	Skyworks	IC, 5-Channel Digital Isolator, Low-Power, 5 Forward, 150 Mbps, 1 kV, QSOP-16, RoHS
14	1	U3	Si8663BD-B-IS	Skyworks	IC, 6-Channel Digital Isolator, Low-Power, 3 Forward/3 Reverse, 150 Mbps, 5 kV, SOL-16, RoHS
15	1	U4	Si8663EC-B-IS1	Skyworks	IC, 6-Channel Digital Isolator, 3 Forward/3 Reverse, Low-Power, 150 Mbps, 3.75 kV, SO-16, RoHS

**\*Note:** All components on this BOM are lead free.



## 6. Ordering Guide

Table 2. Si86xxISO Evaluation Board Ordering Guide

Ordering Part Number (OPN)	Description
Si86xxISO-KIT	Si86xx CMOS digital isolator evaluation board kit

## DOCUMENT CHANGE LIST

### Revision 0.1 to Revision 0.2

- Updated BOM and schematics to reflect change from Rev A to Rev B silicon.

## NOTES: