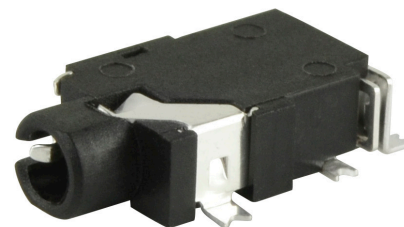
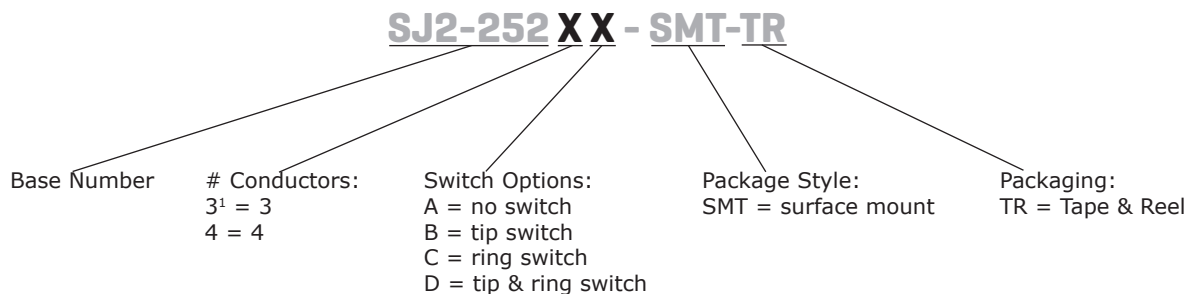

SERIES: SJ2-252X-SMT | **DESCRIPTION:** AUDIO JACK**FEATURES**

- multiple switch configurations
- low profile design
- reflow solder compatible
- surface mount

**PART NUMBER KEY**

Note: 1. 3 conductor option only available with tip & ring switch

SPECIFICATIONS

parameter	conditions/description	min	typ	max	units
rated input voltage			12		Vdc
rated input current				1	A
contact resistance ²	between terminal and mating plug between terminal in a closed circuit			50 30	mΩ mΩ
insulation resistance	at 500 Vdc	100			MΩ
voltage withstand	for 1 minute			500	Vac
insertion/withdrawal force		0.3		3	kg
operating temperature		-25		85	°C
life	at a rate of 24 cycles/minute		5,000		cycles
flammability rating	UL94V-0				
RoHS	yes				

Note: 2. When measured at a current of less than 100 mA/1 kHz
3. All specifications measured at 10~35°C, humidity at 45~85%, under standard atmospheric pressure, unless otherwise noted.

MECHANICAL DRAWING

units: mm
 tolerance:
 X.X ±0.2 mm
 X.XX ±0.10 mm
 X.XXX ±0.050 mm
 PCB: ±0.05 mm

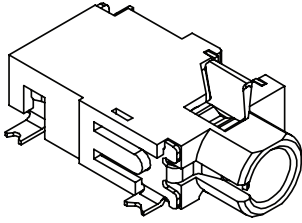

	MATERIAL	PLATING
terminal 1	copper alloy	silver
terminal 2	copper alloy	silver
terminal 3	copper alloy	silver
terminal 4	copper alloy	silver
terminal 10	brass	silver
terminal 11	brass	silver
plastic	PA10T	

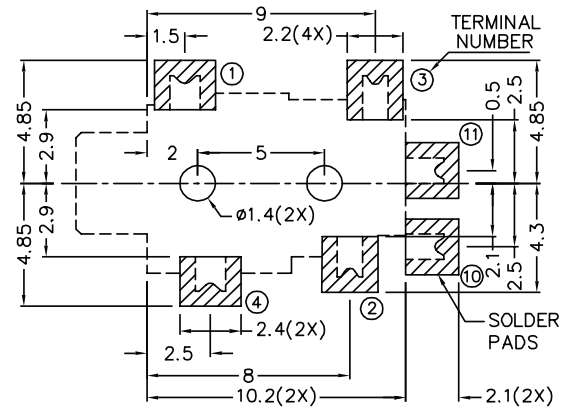
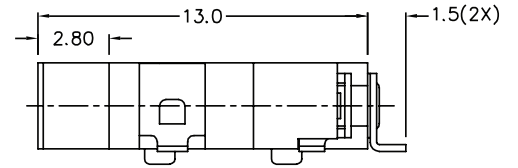
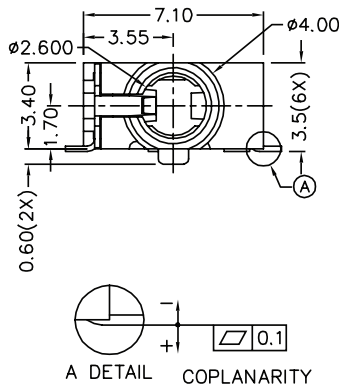
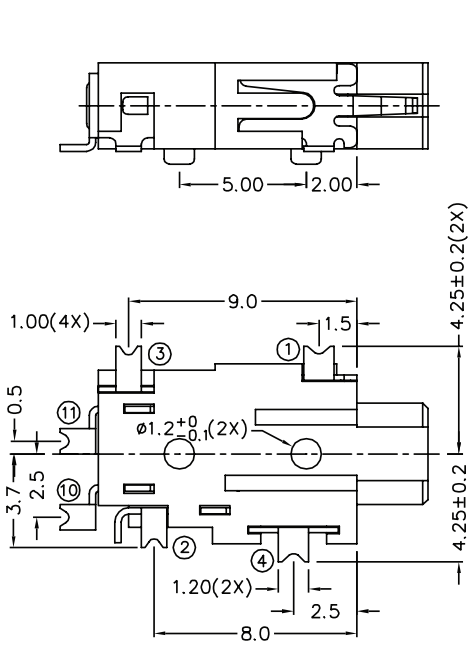

Recommended PCB Layout
Top View

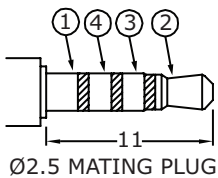

Model No.	SJ2-2523D-SMT	SJ2-2524A-SMT	SJ2-2524B-SMT	SJ2-2524C-SMT	SJ2-2524D-SMT
Schematic					
PIN					
1	NP	sleeve	sleeve	sleeve	sleeve
2	tip	tip	tip	tip	tip
3	ring 1	ring 1	ring 1	ring 1	ring 1
4	ring 2	ring 2	ring 2	ring 2	ring 2
10	tip switch	NP	tip switch	NP	tip switch
11	ring 1 switch	NP	NP	ring 1 switch	ring 1 switch

SOLDERABILITY

parameter	conditions/description	min	typ	max	units
reel storage	at relative humidity <80%			40	°C
reflow soldering ¹	see reflow profile	255	260	265	°C
drying conditions ²	parts in reel: bake at 40°C ±5°C for 72 hours parts removed from reel: bake at 40°C ±5°C for 10 hours				

Note: 1. Must reflow solder within 72 hours from opening vacuum packaging at a temperature <30°C & relative humidity <60%.
2. When exceeding floor life by >72 hours.



PACKAGING

units: mm

Reel Size: Ø381 mm
Reel QTY: 1,200 pcs per reel

