

4DLCD-FT843

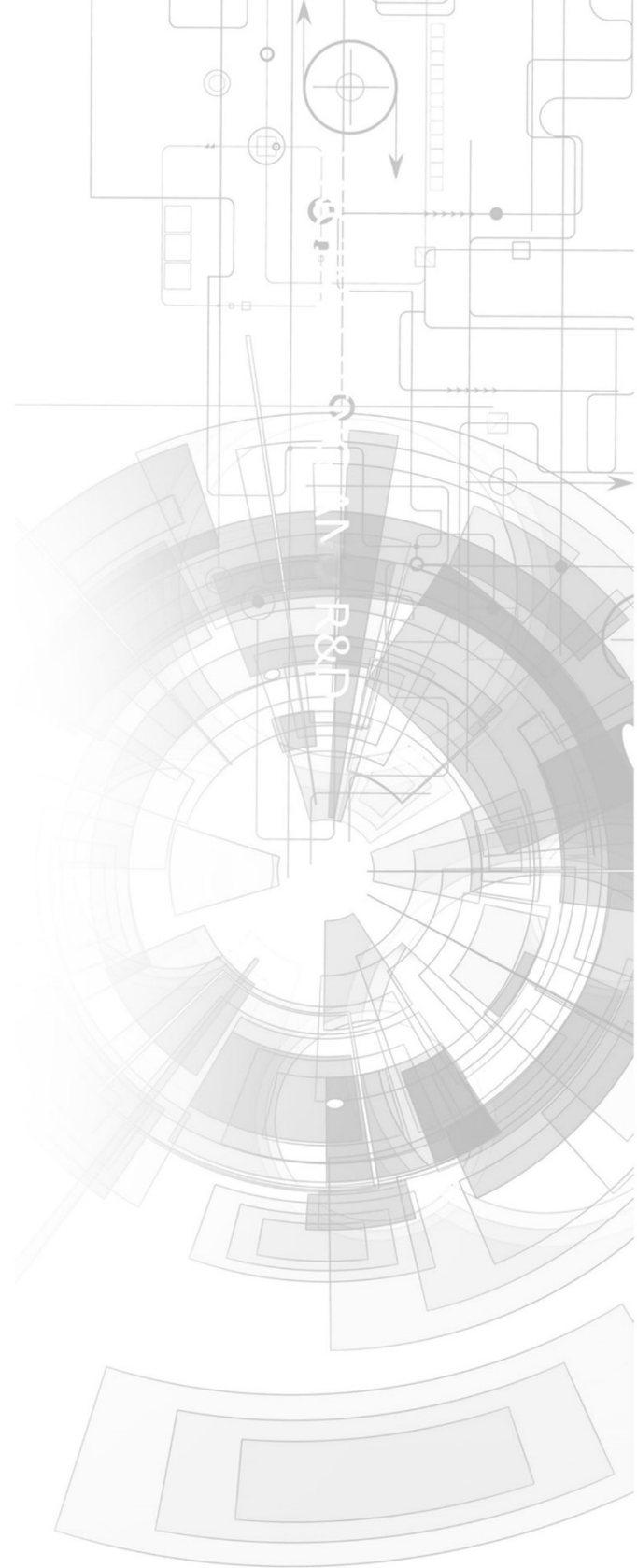

Datasheet

Revision 1.3

Copyright © 2023 4D Systems

Content may change at any time. Please refer to the resource centre for latest documentation.

Contents

1. Description	3
2. Features	4
3. Display Flex Pin Out and Dimensions	5
4. Hardware Interface Pins	7
4.1. Pin Detail	7
4.2. Connection Detail	9
5. Mechanical Dimensions	10
6. Audio Filter and Amplifier Reference Circuit	11
7. Specifications	12
8. Revision History	13

1. Description

The 4DLCD-FT843 is an embedded SPI display from 4D Systems, featuring a 4.3" resistive touch display with an integrated FTDI FT800 Video Engine.

The 4DLCD-FT843 is a powerful SPI Display that enables an SPI host to be connected directly to the display, providing a powerful set of graphics features to the host using the onboard FTDI FT800 Video Engine.

This display provides 4-in-one functionality, a 4.3" TFT LCD Display, Audio with an amplifier enable, and Resistive Touch screen and an integrated Video Engine. This combination built directly into the screen allows for simple integration into several applications.

The FT800 Video Engine runs the FTDI version of EVE (Embedded Video Engine), which targets high-quality graphics displays with Widget support, designed to offload the Host Processor and provide a variety of graphics features.

4D Systems has designed an Arduino Compatible Shield nicknamed ADAM (Arduino Display Adaptor Module) to interface with the EVE-driven 4DLCD-FT843 Display, along with a simple breakout board (4DLCD-FT843-Breakout) to attach to a generic host or breadboard.

All software support for the 4DLCD-FT843 Display is provided directly from FTDI. FTDI also writes and supplies the libraries and demos for this shield/display combo. Hardware support is provided by 4D Systems.

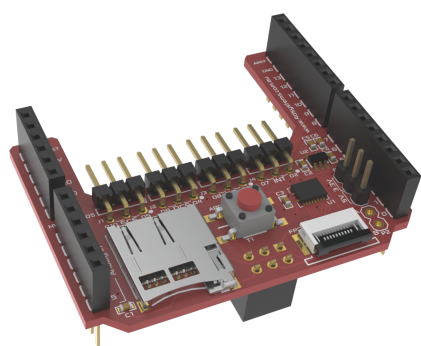

ADAM Shield for Arduino

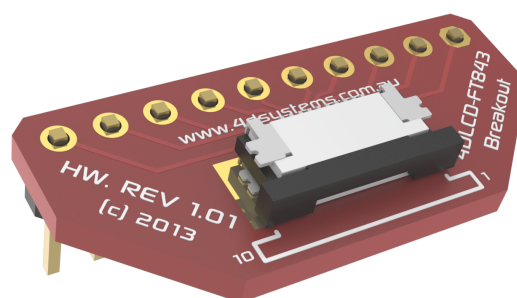

4DLCD-FT843 Breakout

2. Features

- 4.3" TFT LCD Transmissive Display with 480x272 Resolution, and 262K Colours
- 4 Wire Resistive Touch screen
- Mono PWM Audio output with a separate amplifier enable, designed to be connected directly to a simple filter and amplifier circuit.
- On-board FTDI FT800 Video Engine
- SPI Interface to Host Processor/Controller, up to 30Mhz (Mode 0 only)
- Standard 10-way 0.5mm pitch FPC ribbon which carries SPI, Audio, I/O and Power to/from the Display.
- Programmable Interrupt Controller, with dedicated Interrupt pin to Host
- A 64-voice polyphonic sound synthesizer
- PWM dimming control for LCD backlight
- Power mode control to put the FT800 into sleep and standby modes, with a dedicated power-down pin to Host
- Single 3.3V supply
- 3.3V SPI Bus, Audio Output and amplifier enabled, not 5V tolerant.
- Display Dimensions: 105.5 x 67.2 x 4.2mm (Not including flex)
- Flex length from base of display: 57.51mm
- Viewing Area: 95.04 x 53.86mm
- Touch Area: 96.7 x 55.5mm
- Weight: 60gm
- RoHS Compliant
- CE Compliant

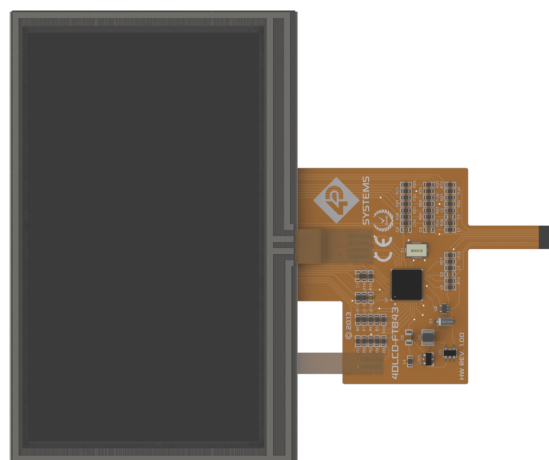

4DLCD-FT843 Display

3. Display Flex Pin Out and Dimensions

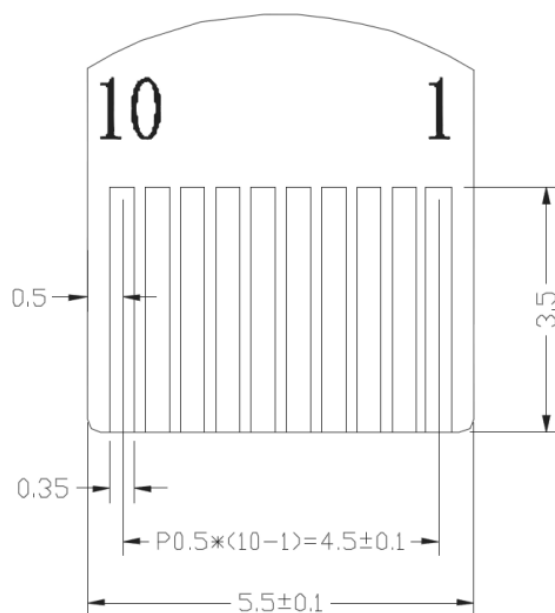

Note

This is the **BACK** view of the Display FPC, opposite side to the components on the Flex.

Flex Pin Out

Pin	Symbol	I/O	Description
1	3.3V	P	3.3V Power Supply for Display Module and FT800 Video Engine. The voltage Input minimum is 3.0V and the maximum is 3.6V, 3.3V is recommended.
2	SCK	I	SPI Clock Input from Host
3	MISO	O	SPI Data Output to Host
4	MOSI	I	SPI Data Input from Host
5	CS	I	SPI Chip Select from Host
6	INT	O	Configurable Interrupt to Host
7	PD	I	Power Down Input from Host
8	AUDIO_SHDN	O	Audio Shutdown Output to Amplifier
9	AUDIO_OUT	O	Audio Output PWM, requires a simple filter and then to Amplifier
10	GND	P	Power Ground

**Note**

I = Input, **O** = Output, **P** = Power

4. Hardware Interface Pins

The 4DLCD-FT843 Display features 10 physical pins on the flex. This section describes each in detail.

4.1. Pin Detail

Pin 1: 3.3V - Power Input:

This is the main power input pin for the display. It powers not only the display logic itself but also the FT800 Video Engine on board the flex, along with the backlight for the 4.3" display. The recommended voltage is 3.3V, however, the display can be powered as low as 3.0V and as high as 3.6V. It is however highly recommended to stay at 3.3V for best results. This also enables interfacing with a 3.3V host processor easier, along with the interface to a micro-SD or SD card, which is also recommended to be at 3.3V.

Pin 2: SCK – SPI Clock:

This is the Clock Input for the SPI Bus which comes from the host. This is 3.3V logic and is not 5V tolerant, please only connect 3.3V compatible devices to this pin. The FT800 can run up to a maximum of 30Mhz on the SPI Bus.

Pin 3: MISO – SPI Data Output:

This is the SPI Data Output from the Display, which goes to the Host processor. This is 3.3V logic and is not 5V tolerant, please only connect 3.3V compatible devices to this pin.

Pin 4: MOSI – SPI Data Input:

This is the SPI Data Input for the Display, which comes from the Host processor. This is 3.3V logic and is not 5V tolerant, please only connect 3.3V compatible devices to this pin.

Pin 5: CS – SPI Chip Select Input:

This is the SPI Chip Select Input for the Display, which comes from the Host processor. This is 3.3V logic and is not 5V tolerant, please only connect 3.3V compatible devices to this pin.

Pin 6: INT – Configurable Interrupt Output:

This is the Configurable Interrupt Output from the display, which can be configured to be triggered by several events, and is used to interrupt the Host Processor when the interrupt event occurs.

This is an Open Drain output, which is pulled high to 3.3V by the display module and is Active Low.

Pin 7: PD – Power Down Input:

This is the Power Down Input for the Display, which can be triggered by the Host Processor if the display is required to be powered down, either from a standby state or from its active state.

This is pulled high to 3.3V by the display module and is Active Low.

Holding this pin low for >5mS will cause the FT800 Video Engine to shut down and go into a powered-down state. Releasing this low or driving the pin High will cause the display to start up again.

It is also possible to reset the display using this pin, by driving it low for 5mS and then high again.

Pin 8: AUDIO_SHDN – Audio Shutdown:

This is the Audio Shutdown output from the FT800 Video Engine, which is designed to enable/disable an external audio amplifier based on the events occurring on the FT800.

This pin is the GPIO01 General Purpose I/O on the FT800, so could be used for an alternative function if required.

Pin 9: AUDIO_OUT – Audio Output:

This is the Audio Output from the FT800 Video Engine, which is a Push/Pull PWM Output capable of Source/Sink of 16mA of current.

This pin is designed to be passed into a simple filter circuit and then passed to an amplifier for best results. Please refer to the example schematic in Section 6 which provides the recommended circuit to connect to this pin.

Pin 10: GND – Power Ground:

This is the Power Ground for the 4DLCD-FT843 Display. This should be connected to the GND associated with the Pin 1 3.3V Power Input pin.

 **Note**

Please refer to the [FT800 Datasheet](#) for more information. Please check FTDI website in case the link is broken.

4.2. Connection Detail

The 4DLCD-FT843 Display features a 10-way flexible FPC, which is designed to connect to a 10-way FPC connector on a PCB.

Please note, the display FPC is fragile and contains many components, so the main body of the FPC should not be bent or subjected to excessive forces or twisted, else the flex may be damaged and the display will no longer function correctly.

Out of the main body of the flex, is a thin portion that contains the 10 signals, which connect to the target PCB's FPC connector. This is also fragile and should be treated with care, it should not be subjected to excessive bending or twisting else it may be damaged.

The 4DLCD-FT843 Display is designed to be easily connected to a target host PCB. 4D Systems offers two products that may be useful.

One is an Arduino Sheild nicknamed ADAM (Arduino Display Adaptor Module), which is designed to connect directly to an Arduino, and features a 10-way FPC connector to connect the 4DLCD-FT843 Display, along with a micro-SD socket and associated jumpers.

The other product is a simple breakout board, which features a 10-way FPC connector, and then a single 2.54mm pitch row of male pins to plug directly into a breadboard or a host PCB.

For detail on these products, please refer to the respective product pages on the 4D Systems website.

The 4DLCD-FT843 Display connects to a target Host Processor / MCU using a 3.3V SPI Bus and also features an Interrupt Pin and Shutdown Pin for applications that can make use of them.

The Display can generate PWM audio, both Mono PCM and Polyphonic MIDI, which exits the display module via the 10-way FPC, and should then be fed into a simple filter and amplifier circuit. This circuit is shown in the [Audio Filter and Amplifier Reference Circuit](#) section and should be treated as the recommended circuit, however, alternative circuits are also possible.

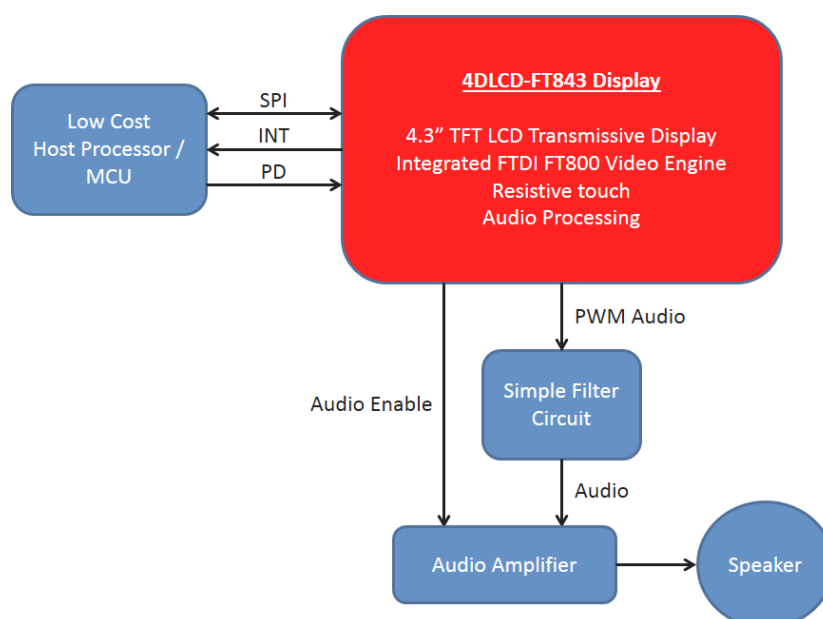

5. Mechanical Dimensions

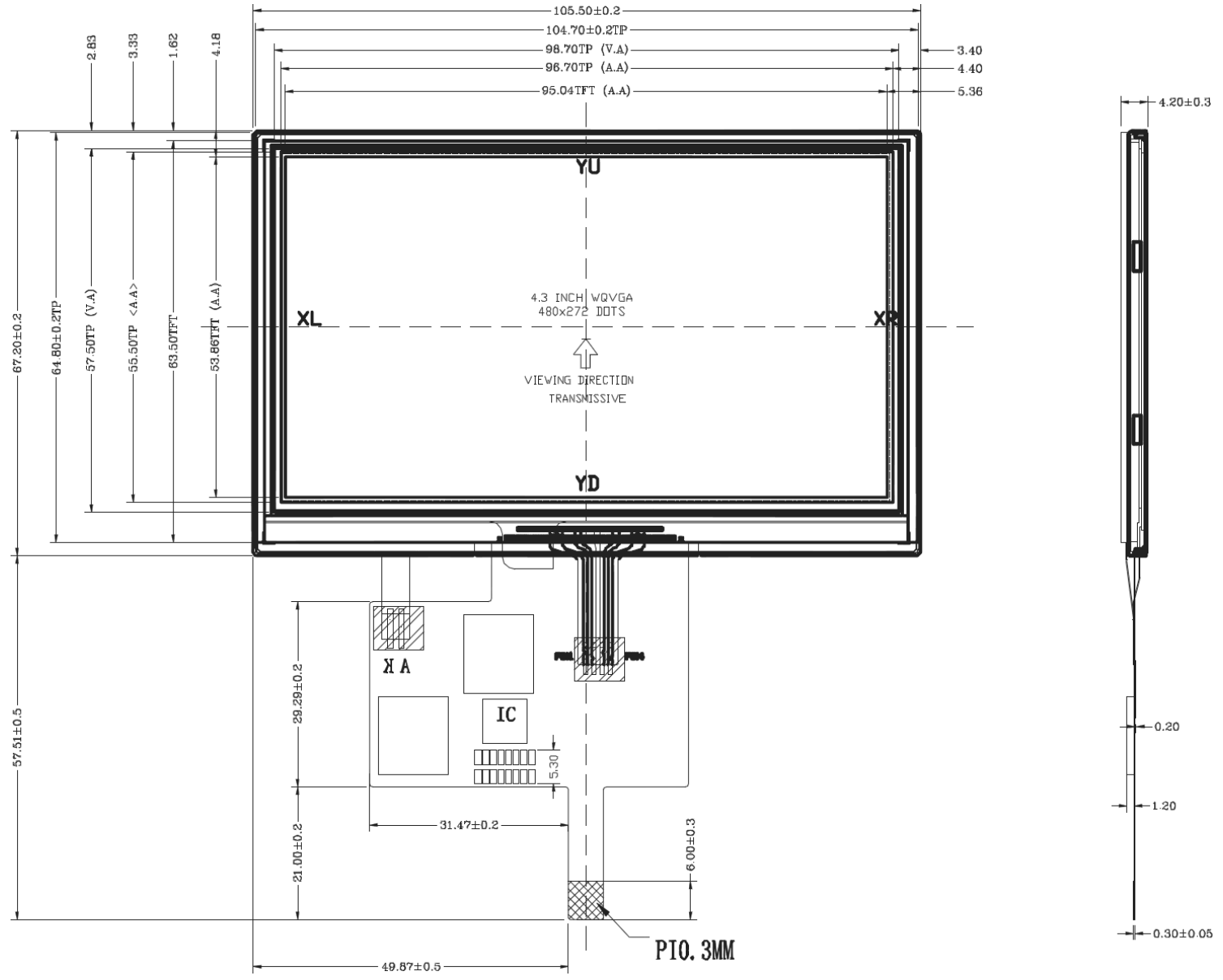

6. Audio Filter and Amplifier Reference Circuit

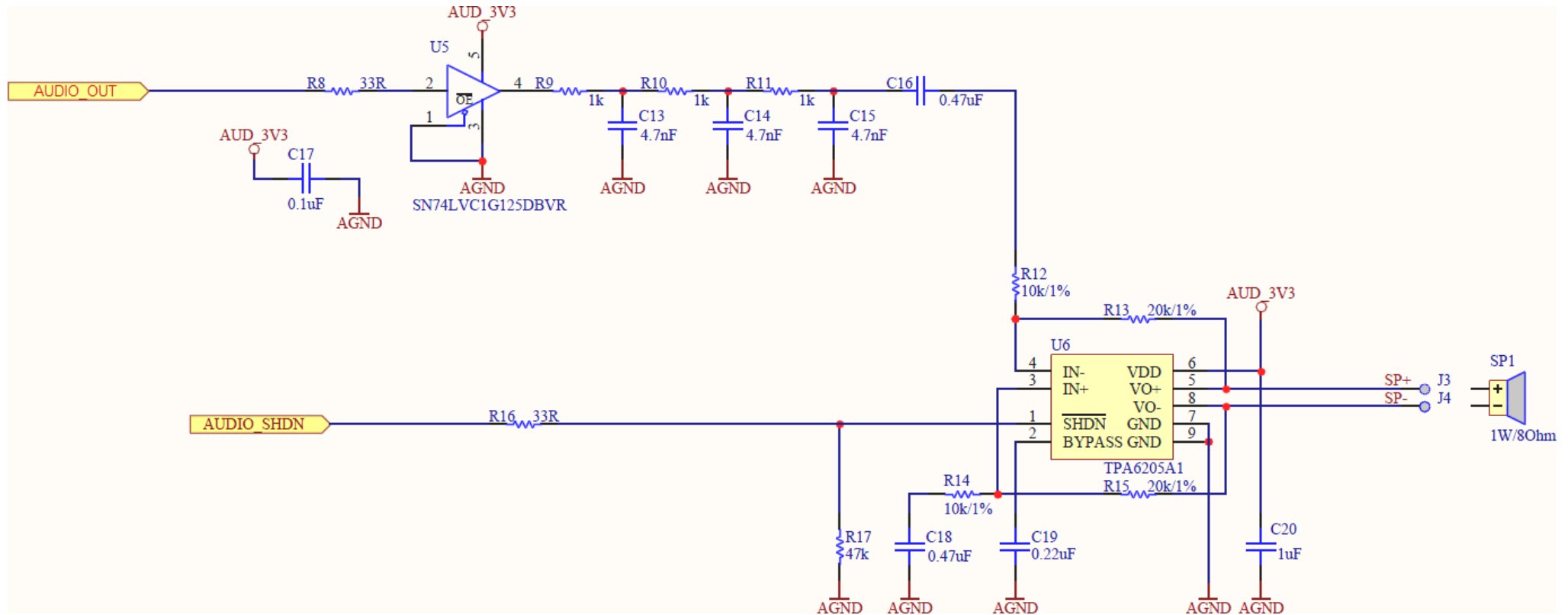

Note

Please note this circuit is not included on any hardware from 4D Systems. This is a reference schematic from FTDI, which can be used to successfully filter and amplify the audio signals coming from the FT800, and therefore 4DLCD-FT843 Display.

7. Specifications

Recommended Operating Conditions

Parameter	Conditions	Min	Typ	Max	Unit
Supply Voltage (VCC)		3.0V	3.3V	3.6V	V
Operating Temperature		-10	--	+70	°C
Typical LCD Life		--	20000	--	Hours
Current Usage	Dependant on usage, audio, brightness, processing, GPIO	--	210	--	mA

Touch Screen Characteristics

Parameter	Conditions	Min	Typ	Max	Unit
Linearity		--	--	<1.5	%
Terminal Resistance X	X film side	200	--	850	Ohms
Terminal Resistance Y	Y film side	150	--	580	Ohms
Durability - Scratch Test	Stylus Pen or Finger Sliding	100	--	--	cycles
Durability - Tap Test	Stylus Pen or Finger Press	1	--	--	Millions
Transparency		--	80	--	%