

Key Design Features

- Synthesizable, technology independent IP Core for FPGA, ASIC and SoC
- Supplied as human readable VHDL (or Verilog) source code
- 32-bit floating-point arithmetic
- IEEE 754 compliant¹
- High-speed fully pipelined architecture
- Only 4 clock-cycles of latency

Applications

- Floating-point pipelines and arithmetic units
- Floating-point processors

Pin-out Description

Pin name	I/O	Description	Active state
clk	in	Synchronous clock	rising edge
en	in	Clock enable	high
v1 [31:0]	in	Input operand 1 in IEEE 754 format	data
v2 [31:0]	in	Input operand 2 in IEEE 754 format	data
vout [31:0]	out	Output result in IEEE 754 format	data

Functional Specification

Operand v1	Operand v2	Result
Standard IEEE	Standard IEEE	v1 + v2 If v1 + v2 > MaxFloat then result is: +/- Inf If v1 + v2 < MinFloat then result is: +/- 0
NaN	Anything	NaN
Anything	NaN	NaN
+/- Inf	- v1	NaN (e.g. -Inf + Inf)
+/- Inf	Standard IEEE	[sign(v1)] Inf

Block Diagram

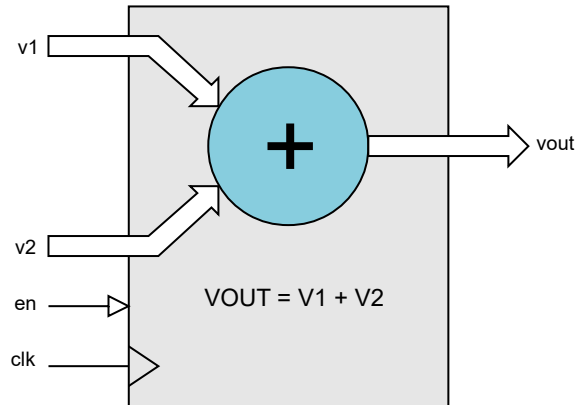
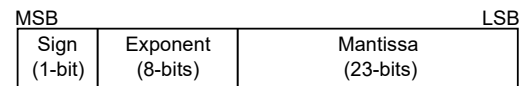

Figure 1: 32-bit Floating-point Adder

General Description

The IEEE_ADD IP Core (Figure 1) is a high-speed fully pipelined 32-bit floating-point adder/subtractor based on the IEEE 754 standard. The arrangement of the 32-bit floating-point number is summarized below:



All input and output values comply with the IEEE 754 specification. The real number representation is calculated according to the formula:

$$Value = -1(S) * 2^{(E-127)} * 1.M$$

There are two exceptions to the IEEE 754 specification. The first being that denormalized (subnormal) numbers are treated as zero throughout the implementation, and the second being that symmetric arithmetic rounding is employed (round half-up).

Other points to note are that NaN is always generated as the value 0xFFC00000. The maximum floating-point value that may be represented is 0x7F7FFFFFFF or 0xFF7FFFFFFF (+/- MaxFloat). Likewise, the minimum floating-point value that may be represented is: 0x00800000 or 0x80800000 (+/- MinFloat). This means that a real number lies in the range:

$$2^{-126} \leq Value \leq 2^{127}(2-2^{-23})$$

All values are sampled on the rising clock-edge of *clk* when *en* is high. The function has a 4 clock-cycle latency².

1 Some minor features diverge from the IEEE 754 specification

2 The design may be optimized for higher-speed or lower latency on request. Please contact Zipcores for more information.

Functional Timing

Figure 2 demonstrates the addition: $0x40010000 + 0x40407000 = 0x40A04000$ (or $2.0010 + 3.0068 = 5.0078$ in real numbers). The result has a latency of 4 clock cycles.

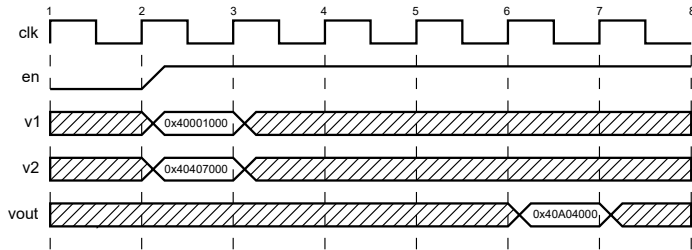

Figure 2: Addition of two floating-point numbers

Source File Description

All source files are provided as text files coded in VHDL. The following table gives a brief description of each file.

Source file	Description
ieee_add.vhd	Top-level component
ieee_add_bench.vhd	Top-level test bench

Functional Testing

An example VHDL testbench is provided for use in a suitable VHDL simulator. The compilation order of the source code is as follows:

1. ieee_add.vhd
2. ieee_add_bench.vhd

The simulation must be run for at least 2 ms during which time an input stimulus of randomized floating-point numbers will be generated at the adder input.

The simulation generates two text files called: *ieee_add_in.txt* and *ieee_add_out.txt*. These files respectively contain the input and output floating-point numbers during the course of the test.

Synthesis and Implementation

The source file 'ieee_add.vhd' is the only file required for synthesis. There are no sub-modules in the design.

The VHDL core is designed to be technology independent. However, as a benchmark, synthesis results have been provided for the Xilinx® 7-series FPGAs. Synthesis results for other FPGAs and technologies can be provided on request.

Resource usage is specified after Place and Route.

XILINX® 7-SERIES FPGAS

Resource type	Artix-7	Kintex-7	Virtex-7
Slice Register	262	262	262
Slice LUTs	465	463	461
Block RAM	0	0	0
DSP48	0	0	0
Occupied Slices	150	147	143
Clock freq. (approx)	200 MHz	250 MHz	300 MHz

Revision History

Revision	Change description	Date
1.0	Initial revision	30/04/2008
1.1	Updated synthesis results	20/08/2009
1.2	Updated functional specification. Updated synthesis results in line with minor code changes	19/09/2011
1.3	Cosmetic changes to the source code Updated results for Xilinx® 7-series	02/07/2018
1.4	Modified design to have a latency of 4 clock cycles	09/07/2018