

DATA SHEET

SKY12325-350LF: 0.5-6.0 GHz Three-Bit Digital Attenuator (1 dB LSB)

Applications

- Cellular Bluetooth® systems
- General-purpose level control

Features

- Broadband operation: 0.5 to 6.0 GHz
- Attenuation: 7 dB
- Positive control voltage
- Resolution: 1 dB
- Miniature QFN (16-pin, 3 x 3 mm) package (MSL1, 260 °C per JEDEC J-STD-020)

 Skyworks Pb-free products are compliant with all applicable legislation. For additional information, refer to *Skyworks Definition of Lead (Pb)-Free*, document number SQ04-0073.

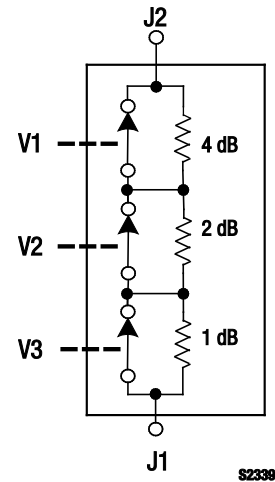

Figure 1. SKY12325-350LF Block Diagram

Description

The SKY12325-350LF is a three-bit digital attenuator. The attenuation bits are binary weighted, with the Least Significant Bit (LSB) equal to 1 dB. States are selected by three positive voltage control inputs (pins V1, V2, and V3). DC blocking capacitors are required at each RF port. Both RF ports are absorptive.

The SKY12325-350LF is provided in a miniature 3 x 3 mm, 16-pin exposed pad plastic Quad Flat No-Lead (QFN) package. A functional block diagram is shown in Figure 1. The pin configuration and package are shown in Figure 2. Signal pin assignments and functional pin descriptions are provided in Table 1.

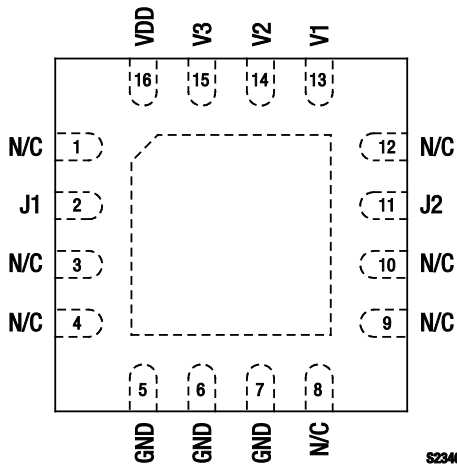

Figure 2. SKY12325-350LF Pinout – 16-Pin QFN (Top View)

Table 1. SKY12325-350LF Signal Descriptions

Pin #	Name	Description	Pin #	Name	Description
1	N/C	No connection	9	N/C	No connection
2	J1	RF input or output port. An external 47 pF (recommended value) DC blocking capacitor is required.	10	N/C	No connection
3	N/C	No connection	11	J2	RF input or output port. An external 47 pF (recommended value) DC blocking capacitor is required.
4	N/C	No connection	12	N/C	No connection
5	GND	Ground	13	V1	High impedance control voltage input for 4 dB weighted bit (MSB)
6	GND	Ground	14	V2	High impedance control voltage input for 2 dB weighted bit
7	GND	Ground	15	V3	High impedance control voltage input for 1 dB weighted bit (LSB)
8	N/C	No connection	16	VDD	Supply voltage

Note: Exposed paddle must be grounded.

Table 2. SKY12325-350LF Absolute Maximum Ratings

Parameter	Symbol	Minimum	Maximum	Units
RF input power	P _{IN}		+30	dBm
Supply voltage	V _S		+6	V
Control voltage	V _{CTL}	0	+6	V
Operating temperature	T _{OP}	-40	+85	°C
Storage temperature	T _{STG}	-65	+150	°C

Note: Exposure to maximum rating conditions for extended periods may reduce device reliability. There is no damage to device with only one parameter set at the limit and all other parameters set at or below their nominal value. Exceeding any of the limits listed here may result in permanent damage to the device.

CAUTION: Although this device is designed to be as robust as possible, Electrostatic Discharge (ESD) can damage this device. This device must be protected at all times from ESD. Static charges may easily produce potentials of several kilovolts on the human body or equipment, which can discharge without detection. Industry-standard ESD precautions should be used at all times.

Electrical and Mechanical Specifications

The absolute maximum ratings of the SKY12325-350LF are provided in Table 2. Electrical specifications are provided in Table 3.

Typical performance characteristics of the SKY12325-350LF are illustrated in Figures 3 through 6.

The state of the SKY12325-350LF is determined by the logic provided in Table 4.

Table 3. SKY12325-350LF Electrical Specifications (Note 1)**($V_{CTL} = 0/5\text{ V}$, $T_{OP} = +25\text{ }^{\circ}\text{C}$, $P_{IN} = 0\text{ dBm}$, Characteristic Impedance [Z_0] = $50\ \Omega$, Unless Otherwise Noted)**

Parameter	Symbol	Test Condition	Min	Typical	Max	Units
Insertion loss	IL	0.5 to 3.0 GHz		0.7	0.9	dB
		3.0 to 4.5 GHz		0.9	1.1	dB
		4.5 to 6.0 GHz		1.3	1.5	dB
Attenuation	ATTN				7	dB
Attenuation accuracy		0.5 to 4.0 GHz	$\pm(0.2 + 3\%$ of attenuation setting)			dB
		4.0 to 6.0 GHz	$\pm(0.3 + 3\%$ of attenuation setting)			dB
Return loss	RL	0.5 to 3.5 GHz		15		dB
		3.5 to 6.0 GHz		15		dB
1 dB Input Compression Point	IP1dB	0.5 to 6.0 GHz $V_{DD} = 3\text{ V}$ $V_{DD} = 5\text{ V}$		+24		dBm
				+27		dBm
3 rd Order Input Intercept Point	IIP3	0.5 to 6.0 GHz, for two-tone input power, +5 dBm/tone, $\Delta f = 1\text{ MHz}$ $V_{LOW} = 0\text{ V}$, $V_{HIGH} = 3\text{ V}$ $V_{LOW} = 0\text{ V}$, $V_{HIGH} = 5\text{ V}$		+44		dBm
				+47		dBm
Control voltage: High Low	V_{CTL_H}		$V_{DD} - 0.2$		$V_{DD} + 0.2$	V
	V_{CTL_L}		0		0.8	V
Control port current	I_{CTL}	V_{CTL_L}			50	μA
		V_{CTL_H}			50	μA
Supply voltage	V_S		2.7		5.5	V

Note 1: Performance is guaranteed only under the conditions listed in this Table.

Typical Performance Characteristics

($V_{DD} = 5\text{ V}$, $T_{OP} = +25\text{ }^{\circ}\text{C}$, Characteristic Impedance [Z_0] = $50\ \Omega$, , Unless Otherwise Noted)

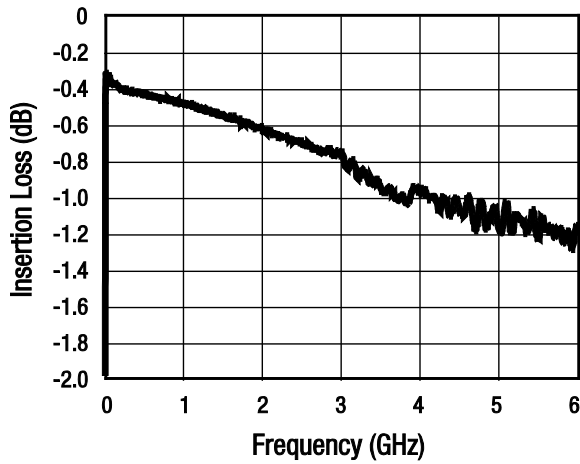

Figure 3. Insertion Loss vs Frequency

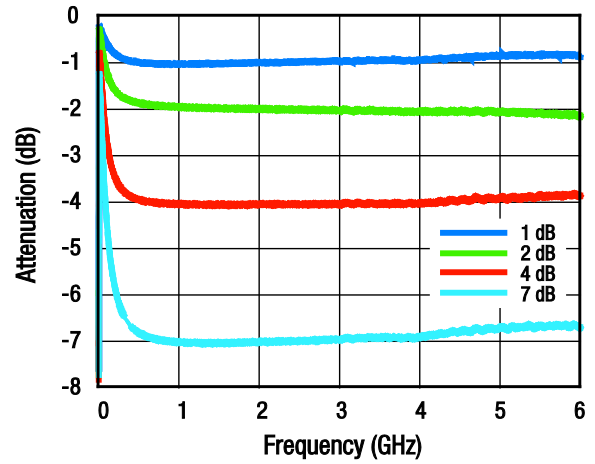

Figure 4. Attenuation vs Frequency (Normalized to Insertion Loss)

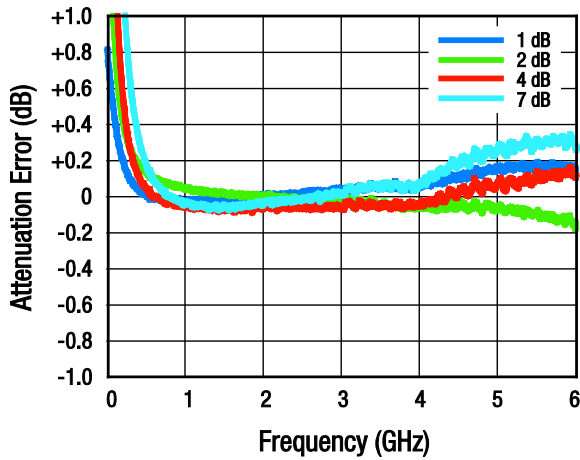

Figure 5. Attenuation Error vs Frequency

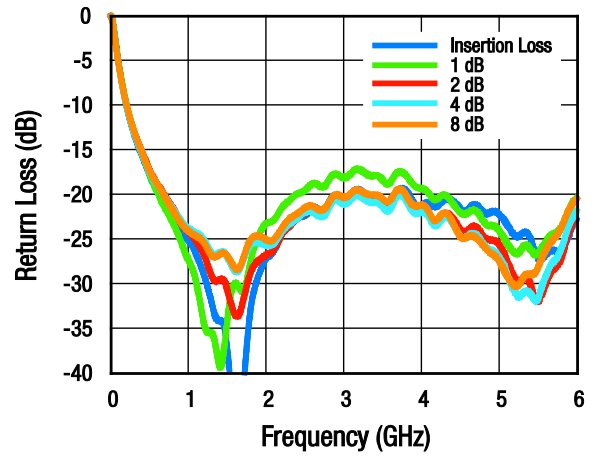

Figure 6. Return Loss vs Frequency

Table 4. SKY12325-350LF Truth Table

Attenuation (Note 1) (dB)	V1 (Pin 13)	V2 (Pin 14)	V3 (Pin 15)
7	Low	Low	Low
6	Low	Low	High
5	Low	High	Low
4	Low	High	High
3	High	Low	Low
2	High	Low	High
1	High	High	Low
0	High	High	High

Note 1: Attenuation normalized to insertion loss.

Note 2: High = +2.7 V to 5.5 V. "Low" = -0.2 V to +0.2 V.

Package Dimensions

The PCB layout footprint for the SKY12325-350LF is shown in Figure 7. Typical case markings are noted in Figure 8. Package dimensions for the 16-pin QFN are shown in Figure 9, and tape and reel dimensions are provided in Figure 10.

THE SKY12325-350LF is rated to Moisture Sensitivity Level 1 (MSL1) at 260 °C. It can be used for lead or lead-free soldering. For additional information, refer to the Skyworks Application Note, *Solder Reflow Information*, document number 200164.

Care must be taken when attaching this product, whether it is done manually or in a production solder reflow environment. Production quantities of this product are shipped in a standard tape and reel format.

Package and Handling Information

Instructions on the shipping container label regarding exposure to moisture after the container seal is broken must be followed. Otherwise, problems related to moisture absorption may occur when the part is subjected to high temperature during solder assembly.

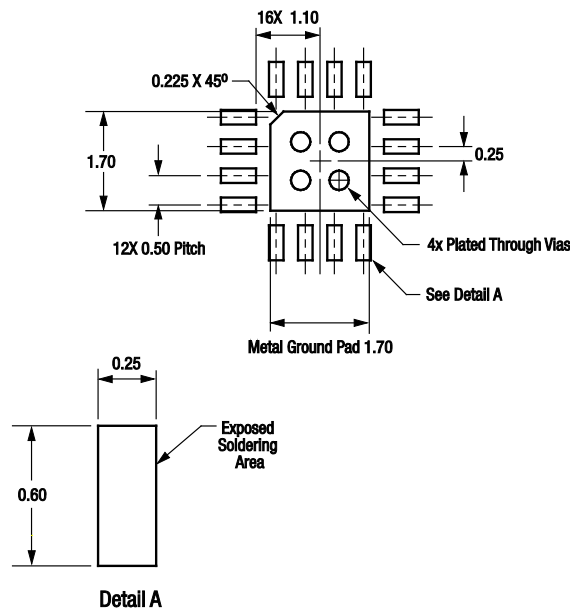

All dimensions are in millimeters

S1691

Figure 7. SKY12325-350LF PCB Layout Footprint

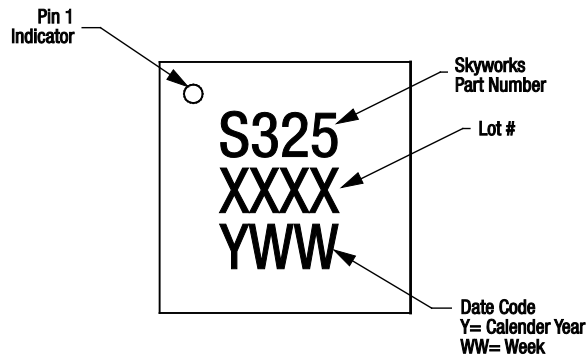
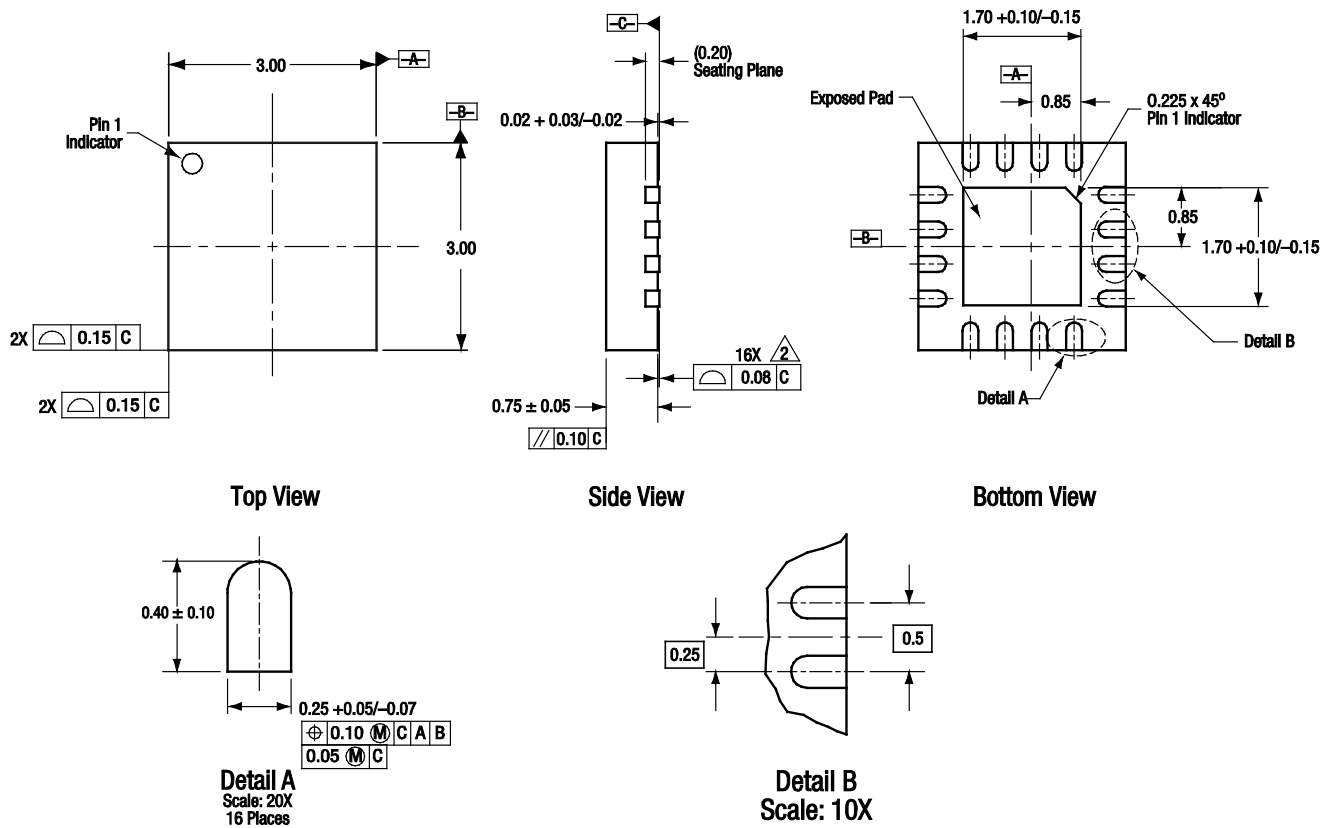

Figure 8. Typical Part Markings



All measurements are in millimeters.
 Dimensioning and tolerancing according to ASME Y14.5M-1994.
 Coplanarity applies to the exposed heat sink slug as well as the terminals.
 Plating requirement per source control drawing (SCD) 2504.

S1692

Figure 9. SKY12325-350LF 16-Pin QFN Package Dimensions

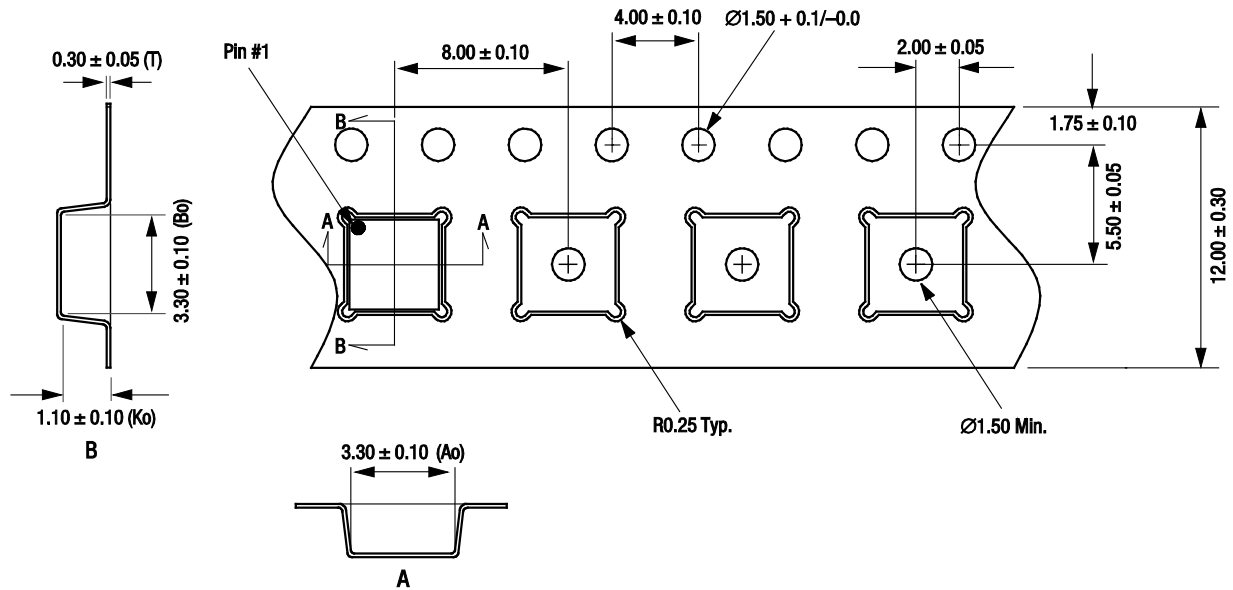

Notes:

1. Carrier tape: black conductive polystyrene, non-bakeable material.
2. Cover tape material: transparent conductive HSA.
3. Cover tape size: 9.20 mm width.
4. All measurements are in millimeters.

S1698

Figure 10. SKY12325-350LF Tape and Reel Dimensions