

**DATA SHEET**

# SKY13377-313LF: 0.5 – 6.0 GHz SPDT 10 W Switch, 50 Ω Terminated

**Applications**

- WiMAX 802.16
- Dual-band WLANs (802.11 a/b/g/n)
- LTE/4G systems

**Features**

- 50 Ω matched RF ports in all states
- Low insertion loss: 0.7 dB @ 2.5 GHz
- High isolation: 31 dB @ 2.5 GHz
- High IP1dB: +39 dBm
- Small, DFN (6-pin, 2 x 3 x 0.9 mm) SMT package (MSL1, 260 °C per JEDEC J-STD-020)

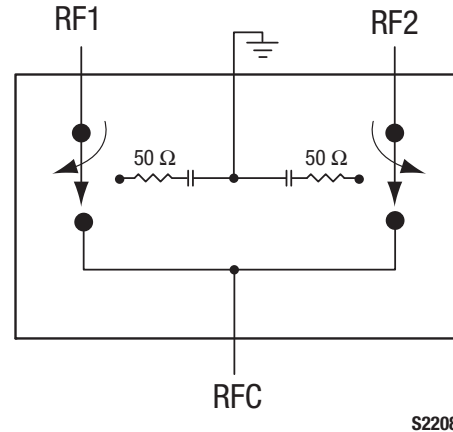

**Figure 1. SKY13377-313LF Block Diagram**



Skyworks Green™ products are compliant with all applicable legislation and are halogen-free. For additional information, refer to *Skyworks Definition of Green™*, document number SQ04-0074.

**Description**

The SKY13377-313LF is a GaAs pHEMT Single-Pole, Double-Throw (SPDT) high power switch with 50 Ω terminated outputs. The high linearity performance and low insertion loss achieved by the SKY13377-313LF make it an ideal choice for WiMAX and WLAN applications.

The switch is manufactured in a compact, 2 x 3 x 0.9 mm, 6-pin Dual Flat No-Lead (DFN) SMT package.

A functional block diagram is shown in Figure 1. The pin configuration and package are shown in Figure 2. Signal pin assignments and functional pin descriptions are provided in Table 1.

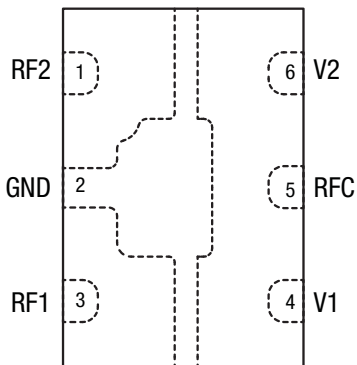

S2484

**Figure 2. SKY13377-313LF Pinout – 6-Pin DFN (Top View)**

**Table 1. SKY13377-313LF Signal Descriptions**

Pin #	Name	Description	Pin #	Name	Description
1	RF2	RF output: 50 Ω terminated when in isolation state. Must be DC blocked.	4	V1	DC control voltage
2	GND	Ground	5	RFC	RF common input. Must be DC blocked.
3	RF1	RF output: 50 Ω terminated when in isolation state. Must be DC blocked.	6	V2	DC control voltage

**Table 2. SKY13377-313LF Absolute Maximum Ratings**

Parameter	Symbol	Minimum	Maximum	Units
Control voltage	V <sub>CTL</sub>		6	V
Input power	P <sub>IN</sub>		+40	dBm
Storage temperature	T <sub>STG</sub>	-40	+125	°C
Operating temperature	T <sub>OP</sub>	-40	+85	°C

**Note:** Exposure to maximum rating conditions for extended periods may reduce device reliability. There is no damage to device with only one parameter set at the limit and all other parameters set at or below their nominal value. Exceeding any of the limits listed here may result in permanent damage to the device.

---

**CAUTION:** Although this device is designed to be as robust as possible, Electrostatic Discharge (ESD) can damage this device. This device must be protected at all times from ESD. Static charges may easily produce potentials of several kilovolts on the human body or equipment, which can discharge without detection. Industry-standard ESD precautions should be used at all times.

---

### Functional Description

Switching is controlled by two control voltage inputs, V1 and V2 (pins 4 and 6, respectively). Depending on the logic voltage level applied to the control pins, the RFC pin is connected to one of the two switched RF outputs, RF1 or RF2, using a low insertion loss path, while the path between the RFC pin and the other RF pin is in a high isolation state.

DC blocking capacitors are required on all RF ports of the switch. The value of the capacitors determines the low frequency operation. The isolated RF output is internally terminated to 50 Ω.

### Electrical and Mechanical Specifications

The absolute maximum ratings of the SKY13377-313LF are provided in Table 2. Electrical specifications are provided in Table 3.

Typical performance characteristics of the SKY13377-313LF are illustrated in Figures 3 through 6.

The state of the SKY13377-313LF is determined by the logic provided in Table 4.

**Table 3. SKY13377-313LF Electrical Specifications (1 of 2) (Note 1)****( $V_{CTL} = 0\text{ V}$  and  $+3.0\text{ V}$ ,  $T_{OP} = +25\text{ }^{\circ}\text{C}$ ,  $P_{IN} = 0\text{ dBm}$ , Characteristic Impedance [ $Z_0$ ] =  $50\text{ }\Omega$ ,  $C_{BLK} = 47\text{ pF}$ , Unless Otherwise Noted)**

Parameter	Symbol	Test Condition	Min	Typical	Max	Units			
<b>RF Specifications</b>									
Insertion loss	IL	RFC to RF1 or RF2:							
		0.500 to 2.70 GHz		0.70	0.80	dB			
		2.70 to 3.80 GHz		0.80	0.95	dB			
Isolation	Iso	RFC to RF1 or RF2:							
		0.500 to 2.70 GHz	29	31	dB				
		2.70 to 3.80 GHz	27	29	dB				
3.80 to 5.85 GHz			22	24	dB				
			Input return loss ("on" state)	IS11l	RFC or RF1 or RF2, 0.5 to 6.0 GHz	10	20	dB	
			Input return loss ("off" state)	IS11l	Isolated output RF1 or RF2:				
2.30 to 2.70 GHz				15		dB			
				2.70 to 3.80 GHz	15		dB		
				3.80 to 5.85 GHz	15		dB		
1 dB Input Compression Point	IP1dB	$V_{CTL} = 3.0\text{ V}$ :							
		2.30 to 2.70 GHz		+39	dBm				
		2.70 to 3.80 GHz		+39	dBm				
3.80 to 5.85 GHz				+39		dBm			
				3 <sup>rd</sup> Order Input Intercept Point	IIP3	$P_{IN} = +27\text{ dBm/ tone}$ , $\Delta f = 1\text{ MHz}$ , $V_{CTL} = 3.0\text{ V}$ :			
							2.4 GHz	62	dB
3.8 GHz	60	dB							
5.8 GHz	57	dB							
2 <sup>nd</sup> harmonic	2fo	$P_{IN} = +27\text{ dBm}$ , $V_{CTL} = 3.0\text{ V}$ :							
			0.9 GHz	+80	dBc				
			2.4 GHz	+78	dBc				
			3.8 GHz	+75	dBc				
5.8 GHz	+73	dBc							
3 <sup>rd</sup> harmonic	3fo	$P_{IN} = +27\text{ dBm}$ , $V_{CTL} = 3.0\text{ V}$ :							
			0.9 GHz	+80	dBc				
			2.4 GHz	+80	dBc				
			3.8 GHz	+80	dBc				
5.8 GHz	+80	dBc							
WLAN Error Vector Magnitude	EVM_WLAN	Input power for 2.5% error, WLAN 2.45 GHz, 802.11g, OFDM, 54 Mbps, 64 QAM		+31		dBm			
WiMAX Error Vector Magnitude	EVM_WiMAX	Input power for 2.5% error, WiMAX 3.8 GHz, OFDMA, 54 Mbps, 64 QAM		+31		dBm			
WLAN Error Vector Magnitude	EVM_WLAN	Input power for 2.5% error, WLAN 5.85 GHz, 802.11g, OFDM, 54 Mbps, 64 QAM		+29		dBm			
Switching speed		50% $V_{CTL}$ to 90/10% RF		150	250	ns			
		90/10% RF or 10/90% RF		150	250	ns			

**Table 3. SKY13377-313LF Electrical Specifications (2 of 2) (Note 1)**

( $V_{CTL} = 0\text{ V}$  and  $+3.0\text{ V}$ ,  $T_{OP} = +25\text{ }^\circ\text{C}$ ,  $P_{IN} = 0\text{ dBm}$ , Characteristic Impedance [ $Z_0$ ] =  $50\text{ }\Omega$ ,  $C_{BLK} = 47\text{ pF}$ , Unless Otherwise Noted)

Parameter	Symbol	Test Condition	Min	Typical	Max	Units
<b>DC Specifications</b>						
Control voltage	$V_{CTL}$		2.5	3.0	5.0	V
Control current	$I_{CC}$	$V_{CTL} = 3\text{ V}$		50		$\mu\text{A}$

Note 1: Performance is guaranteed only under the conditions listed in this Table.

### Typical Performance Characteristics

( $V_{CTL} = 0\text{ V}$  and  $+3.0\text{ V}$ ,  $T_{OP} = +25\text{ }^\circ\text{C}$ ,  $P_{IN} = 0\text{ dBm}$ , Characteristic Impedance [ $Z_0$ ] =  $50\text{ }\Omega$ ,  $C_{BLK} = 47\text{ pF}$ , Unless Otherwise Noted)

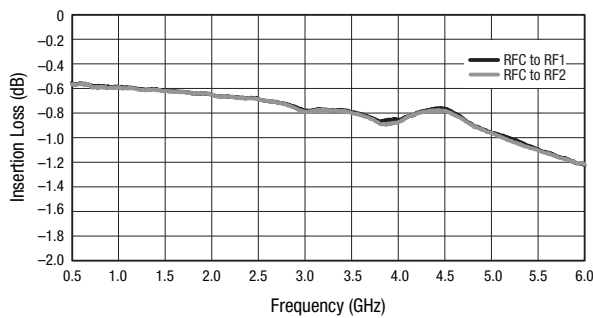

**Figure 3. Typical Insertion Loss vs Frequency**

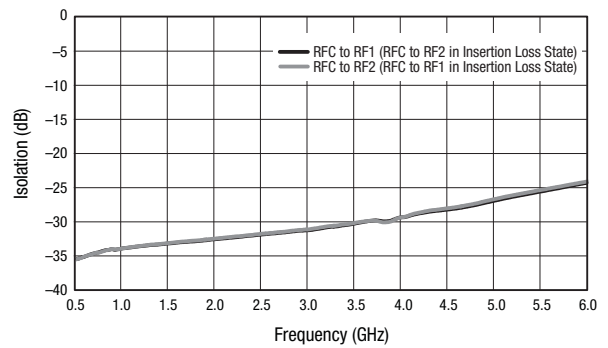

**Figure 4. Typical Isolation vs Frequency**

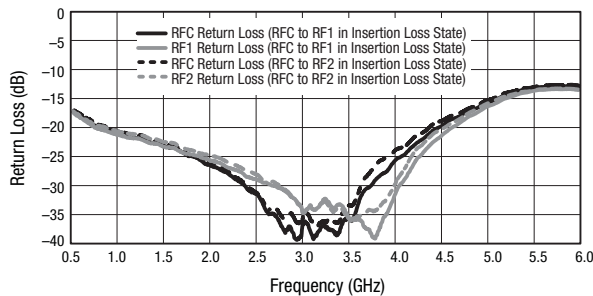

**Figure 5. Return Loss vs Frequency (Insertion Loss State)**

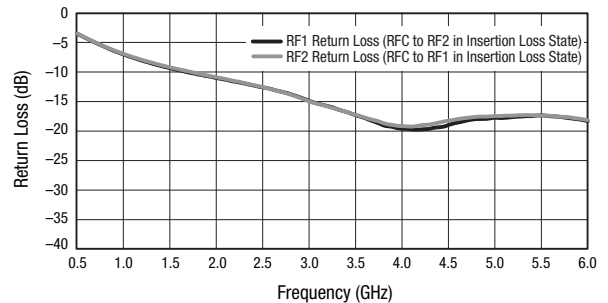

**Figure 6. Return Loss vs Frequency (Isolation State)**

**Table 4. SKY13377-313LF Truth Table**

V1 (Pin 4)	V2 (Pin 6)	Insertion Loss State
1	0	RFC to RF1
0	1	RFC to RF2

**Note:** "1" = +2.5 V to +5.0 V. "0" = 0 V to +0.2 V. Any state other than described in this Table places the switch into an undefined state. An undefined state will not damage the device.

**Evaluation Board Description**

The SKY13377-313LF Evaluation Board is used to test the performance of the SKY13377-313LF SPDT Switch. An Evaluation Board schematic diagram is provided in Figure 7. An assembly drawing for the Evaluation Board is shown in Figure 8.

**Package Dimensions**

The PCB layout footprint for the SKY13377-313LF is provided in Figure 9. Typical case markings are shown in Figure 10. Package dimensions for the 6-pin DFN are shown in Figure 11, and tape and reel dimensions are provided in Figure 12.

**Package and Handling Information**

Instructions on the shipping container label regarding exposure to moisture after the container seal is broken must be followed. Otherwise, problems related to moisture absorption may occur when the part is subjected to high temperature during solder assembly.

The SKY13377-313LF is rated to Moisture Sensitivity Level 1 (MSL1) at 260 °C. It can be used for lead or lead-free soldering. For additional information, refer to the Skyworks Application Note, *Solder Reflow Information*, document number 200164.

Care must be taken when attaching this product, whether it is done manually or in a production solder reflow environment. Production quantities of this product are shipped in a standard tape and reel format.

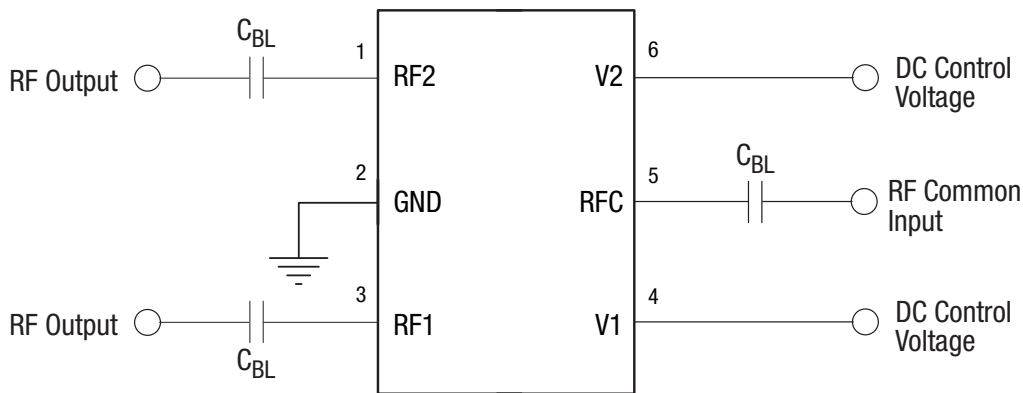

$C_{BL} = 47 \text{ pF}$  for  $>1 \text{ GHz}$  operation. Increase value for lower frequency operation.

Exposed ground paddle should be grounded for best performance.

S2485

**Figure 7. SKY13377-313LF Evaluation Board Schematic**

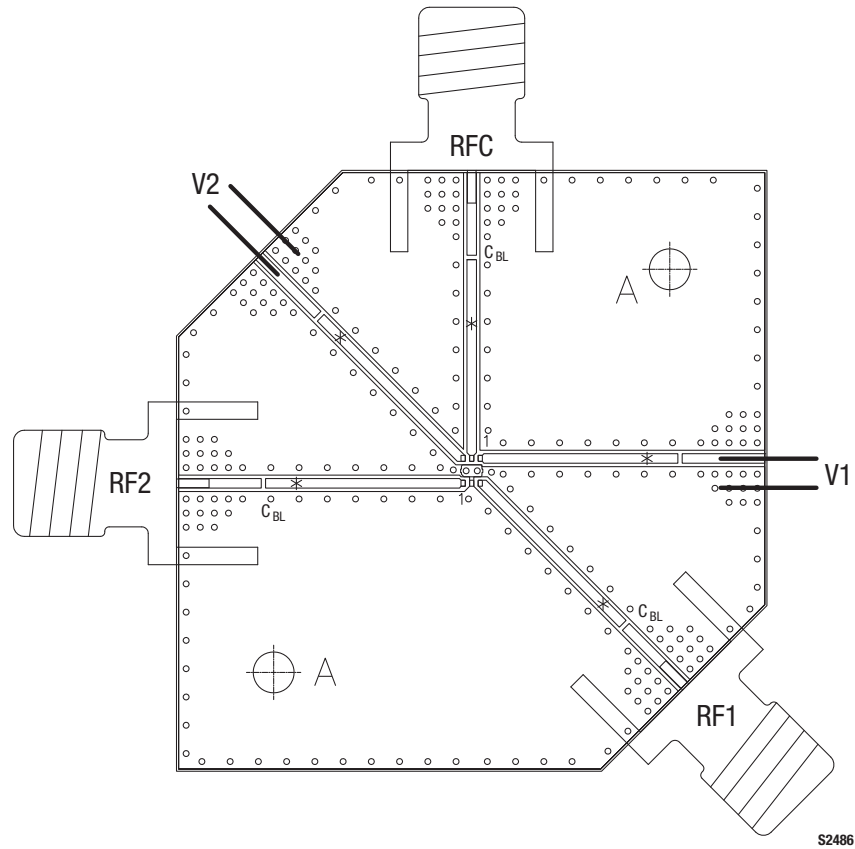
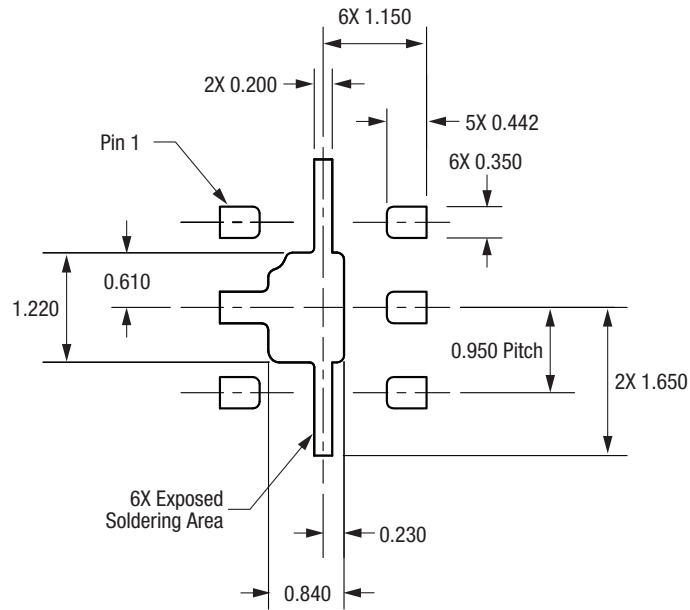
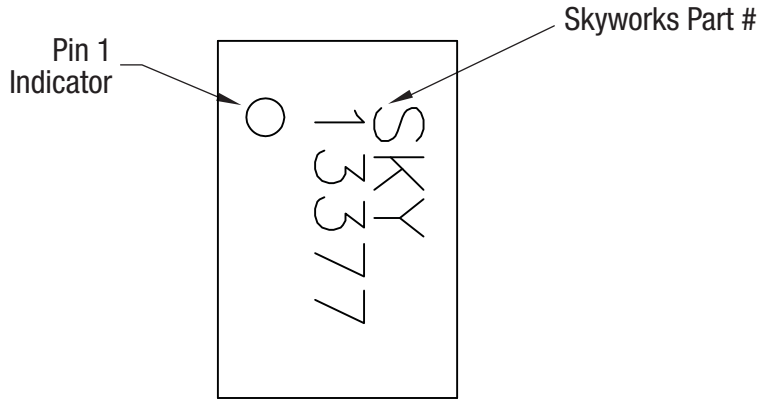

Figure 8. SKY13377-313LF Evaluation Board Assembly Diagram



All dimensions are in millimeters

Figure 9. SKY13377-313LF PCB Layout Footprint (Top View)



**Figure 10. Typical Part Markings (Top View)**

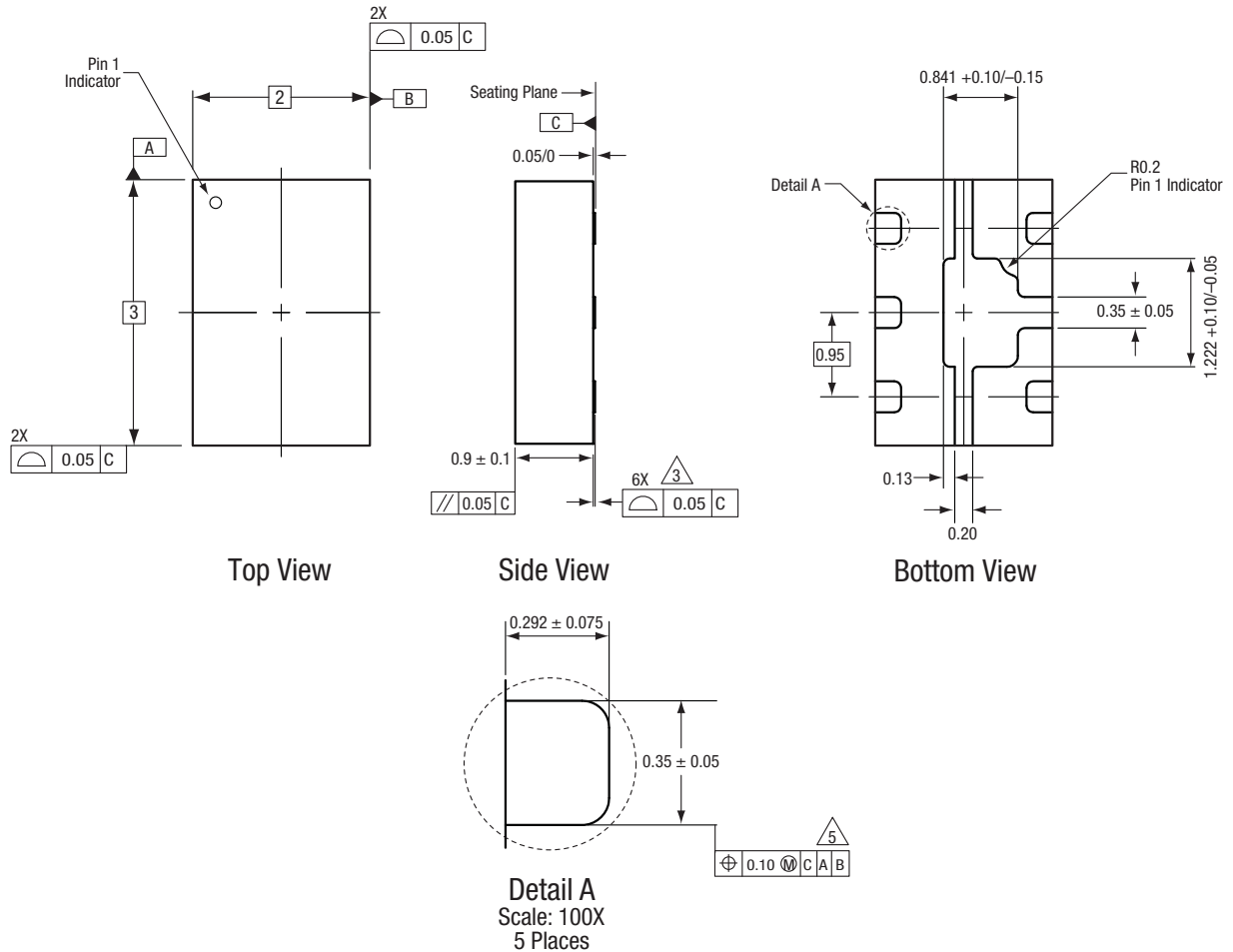

All measurements are in millimeters.  
 Dimensioning and tolerancing according to ASME Y14.5M-1994.  
 Coplanarity applies to the terminals and all other bottom surface metalization.  
 Dimension applies to metalized terminal. If the terminal has a radius on its end, the width dimension should not be measured in that radius area.

S2492

**Figure 11. SKY13377-313LF 6-Pin DFN Package Dimensions**

**DATA SHEET • SKY13377-313LF SPDT SWITCH**

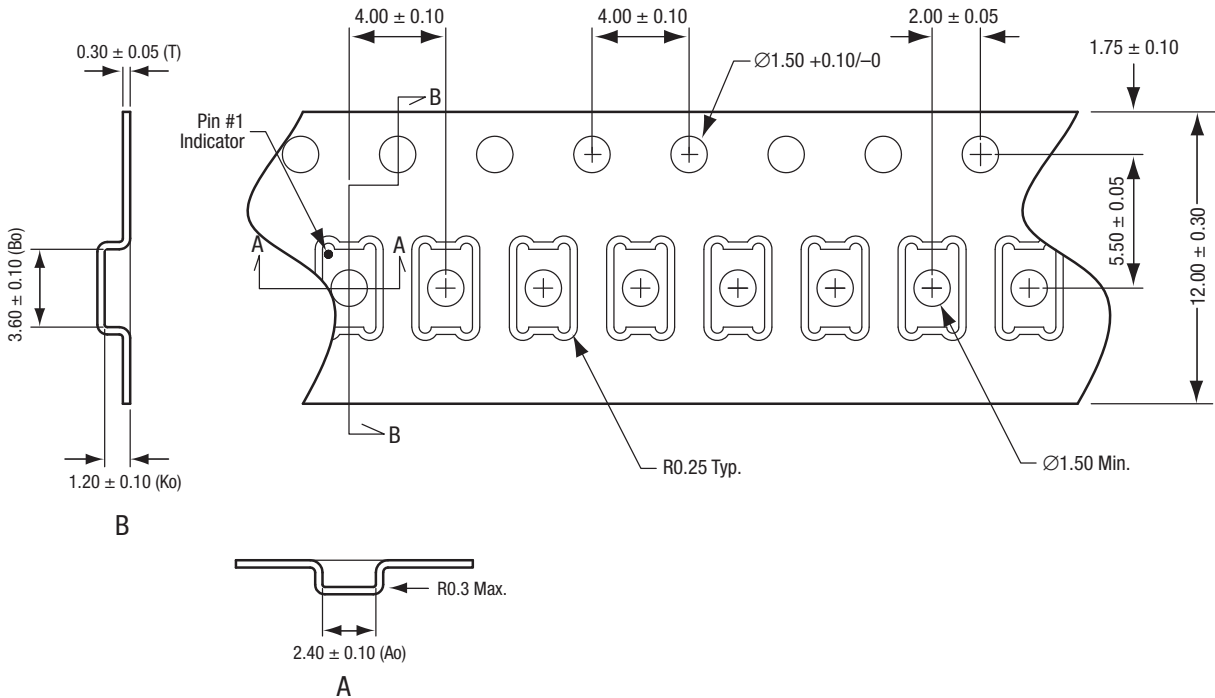

**Notes:**

1. Carrier tape: black conductive polystyrene, non-bakeable material.
2. Cover tape material: transparent conductive HSA with 9.20 mm width.
3. ESD-surface resistivity is  $\geq 1 \times 10^5 \sim \leq 1 \times 10^{10}$  Ohms/square per EIA, JEDEC TNR Specification.
4. All measurements are in millimeters.

S2653

**Figure 12. SKY13377-313LF Tape and Reel Dimensions**