

DATA SHEET

SKY13441: 0.4-2.7 GHz SP10T Switch with GPIO Interface

Applications

- 2G/3G multimode cellular handsets (UMTS, CDMA2000, EDGE, GSM)
- Embedded data cards

Features

- Broadband frequency range: 0.4 to 2.7 GHz
- Single, positive DC power supply (2.5 to 3.3 V)
- Excellent Band 13 2nd harmonic rejection
- Integrated, low-pass harmonic filter for GSM transmit paths
- Integrated GPIO interface
- Any of eight TRX ports can be used for WCDMA transmit/receive or GSM receive functions
- Small MCM (20-pin, 3.2 x 2.5 mm) package (MSL3, 260 °C per JEDEC J-STD-020)



Skyworks Green™ products are compliant with all applicable legislation and are halogen-free. For additional information, refer to *Skyworks Definition of Green™*, document number SQ04-0074.

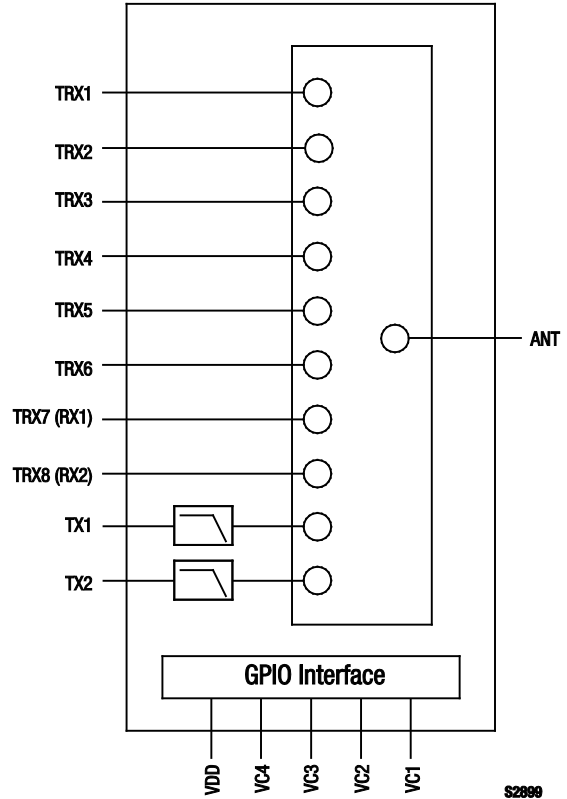

Figure 1. SKY13441 Block Diagram

Description

The SKY13441 is a Single Pole, Ten-Throw (SP10T) antenna switch with an integrated General Purpose Input/Output (GPIO) interface and dual low-pass harmonic filters. The switch has eight transmit/receive ports, any of which can be used for WCDMA transmit/receive or GSM receive functions.

Using advance switching technologies, the SKY13441 maintains low insertion loss and high isolation for both transmit and receive switching paths. The switch also exhibits an excellent triple beat ratio and 2nd/3rd order modulation distortion performance.

Switching is controlled by an integrated GPIO interface. Depending on the logic applied to the decoder, the antenna pin is connected to one of ten switched RF ports using a low insertion loss path, while the paths between the antenna pin and the other RF pins are in a high isolation state. No external DC blocking capacitors are required on the RF paths.

The SKY13441 is manufactured in a compact, 3.2 x 2.5 mm, 20-pin Multi-Chip Module (MCM) package.

A functional block diagram is shown in Figure 1. The pin configuration and package are shown in Figure 2. Signal pin assignments and functional pin descriptions are provided in Table 1.

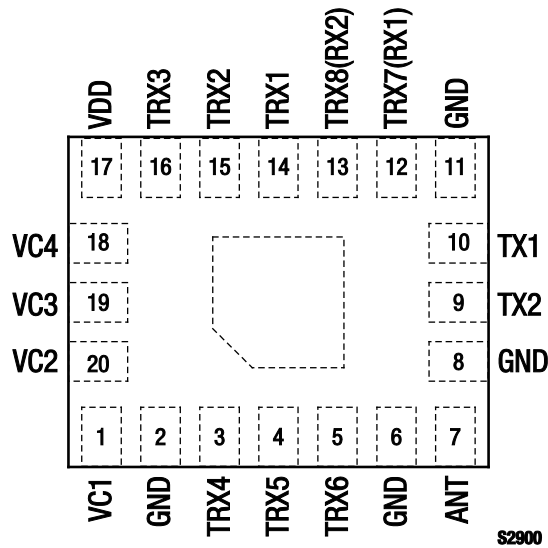

Figure 2. SKY13441 Pinout – 20-Pin MCM (Top View)

Table 1. SKY13441 Signal Descriptions

Pin #	Name	Description	Pin #	Name	Description
1	VC1	DC input control voltage 1	11	GND	Ground
2	GND	Ground	12	TRX7(RX1)	RF input/output port 7
3	TRX4	RF input/output port 4	13	TRX8(RX2)	RF input/output port 8
4	TRX5	RF input/output port 5	14	TRX1	RF input/output port 1
5	TRX6	RF input/output port 6	15	TRX2	RF input/output port 2
6	GND	Ground	16	TRX3	RF input/output port 3
7	ANT	Antenna RF port	17	VDD	DC power supply
8	GND	Ground	18	VC4	DC input control voltage 4
9	TX2	GSM high band transmit RF input port with integrated harmonic filter	19	VC3	DC input control voltage 3
10	TX1	GSM low band transmit RF input port with integrated harmonic filter	20	VC2	DC input control voltage 2

Note: Bottom ground paddles must be connected to ground.

Table 2. SKY13441 Absolute Maximum Ratings

Parameter	Symbol	Minimum	Maximum	Units
RF input power	P _{IN}		+36	dBm
Power supply			5	V
DC control voltage	V _{CTRL}		2.7	V
Storage temperature	T _{STG}	-40	+125	°C
Operating temperature	T _{OP}	-30	+90	°C
Electrostatic Discharge: Charged Device Model (CDM)	ESD		*** TBD ***	V
Human Body Model (HBM)			*** TBD ***	V
Machine Model (MM)			*** TBD ***	V

Note: Exposure to maximum rating conditions for extended periods may reduce device reliability. There is no damage to device with only one parameter set at the limit and all other parameters set at or below their nominal value. Exceeding any of the limits listed here may result in permanent damage to the device.

CAUTION: Although this device is designed to be as robust as possible, Electrostatic Discharge (ESD) can damage this device. This device must be protected at all times from ESD. Static charges may easily produce potentials of several kilovolts on the human body or equipment, which can discharge without detection. Industry-standard ESD precautions should be used at all times.

Electrical and Mechanical Specifications

The absolute maximum ratings of the SKY13441 are provided in Table 2. Electrical specifications are provided in Table 3. Table 4 provides the control logic for the SKY13441.

Typical performance characteristics of the SKY13441 are illustrated in Figures 3 to 13.

The isolation matrices shown in Tables 5 and 6 provide the port-to-port isolation and the antenna-to-port isolation for all available RF states at four different frequencies: 915, 1910, 2170, and 2690 MHz.

The insertion loss matrix shown in Table 7 provides the insertion loss for all available RF states at eight different frequencies: 704, 824, 915, 960, 1710, 1910, 2170, and 2690 MHz.

Figure 14 illustrates the test setup used to measure data for Figure 11. This industry standardized test is used to simulate the WCDMA Band 1 linearity of the antenna switch. A +20 dBm Continuous Wave (CW) signal, f_{FUND}, is sequentially applied to the TRX1 through TRX8 ports, while a -15 dBm CW blocker signal, f_{BLK}, is applied to the ANT port.

The resulting 3rd Order Intermodulation Distortion (IMD3), f_{IMD3}, is measured over all phases of f_{FUND}. The SKY13441 exhibits exceptional performance for all TRX ports.

Table 3. SKY13441 Electrical Specifications (Note 1) (1 of 2)

(V_{DD} = 2.85 V, VC1 = VC2 = VC3 = VC4 = 0/1.8 V, T_{OP} = +25 °C, P_{IN} = 0 dBm, Characteristic Impedance [Z₀] = 50 Ω, Unless Otherwise Noted)

Parameter	Symbol	Test Condition	Min	Typical	Max	Units
RF Specifications						
Insertion loss: ANT to TRX1 through TRX8 ports	IL	704 to 960 MHz		0.5	0.80	dB
		1710 to 2170 MHz		0.6	0.95	dB
		2300 to 2690 MHz		0.9	1.20	dB
Insertion loss: TRX4	IL	704 to 787 MHz		0.4	0.7	dB
Insertion loss: ANT to TX1 port	IL	824 to 915 MHz		1.35	1.55	dB
Insertion loss: ANT to TX2 port	IL	1710 to 1910 MHz		1.2	1.4	dB
Isolation: TRX1/2/3/7/8 to TRX4/5/6 ports	Iso	824 to 1910 MHz	38	45		dB
Isolation: TX1 to TRX1 through TRX8 ports	Iso	824 to 915 MHz	35	44		dB
Isolation: TX2 to TRX1 through TRX8 ports	Iso	1710 to 1910 MHz	32	39		dB
Isolation: TRX4 to TRX6 port	Iso	824 to 1910 MHz	28	31		dB
Isolation: TRX adjacent ports	Iso	824 to 1910 MHz	21	24		dB
		1910 to 2690 MHz		20		dB
Band 13 2 nd harmonic	B13 2fo	P _{IN} = +25 dBm, f = 787 MHz, TRX1 to TRX8		-81		dBm
Harmonics		UMTS, P _{IN} = +27 dBm: TX1 port, P _{IN} = +35 dBm		-48	-36	dBm
		TX2 port, P _{IN} = +33 dBm		-45	-36	dBm
				-45	-36	dBm
Attenuation (TX1 port)		GSM850: 2f	25	28		dB
		3f	25	28		dB
		>4f		20		dB
		EGSM900: 2f	25	28		dB
		3f	22	25		dB
		>4f		20		dB
Attenuation (TX2 port)		DCS1800: 2f	25	28		dB
		3f	25	28		dB
		>4f		20		dB
		PCS1900: 2f	25	28		dB
		3f	24	28		dB
		>4f		20		dB
Return loss	IS111	0.4 to 2.2 GHz	14	18		dB
2nd Order Input Intercept Point	IIP2	AWS, PCS, IMT to CDMA2000 modes	+95.5			dBm
2nd Order Intermodulation Distortion	IMD2	UMTS mode			-105	dBm
3rd Order Intermodulation Distortion	IMD3	UMTS mode		-110	-105	dBm

Table 3. SKY13441 Electrical Specifications (Note 1) (2 of 2)

($V_{DD} = 2.85\text{ V}$, $VC1 = VC2 = VC3 = VC4 = 0/1.8\text{ V}$, $T_{OP} = +25\text{ }^{\circ}\text{C}$, $P_{IN} = 0\text{ dBm}$, Characteristic Impedance [Z_0] = $50\text{ }\Omega$, Unless Otherwise Noted)

Parameter	Symbol	Test Condition	Min	Typical	Max	Units
RF Specifications (continued)						
Triple Beat Ratio	TBR	650 to 900 MHz	81			dBc
		1710 to 2155 MHz	81			dBc
1 dB Input Compression Point	IP1dB	TX1 port, 824 to 915 MHz	+40			dBm
		TX2 port, 1710 to 1910 MHz	+39			dBm
Switching speed		10/90% RF		3	5	μs
DC Specifications						
Supply voltage	V_{DD}		2.50	2.85	3.30	V
Supply current	I_{DD}			50	100	μA
Control voltage: High Low	VC1, VC2, VC3, VC4		1.35	1.80	2.50	V
			0		0.45	V
Control current: High Low					10	μA
				5		μA

Note 1: Performance is guaranteed only under the conditions listed in this Table.

Table 4. SKY13441 Mode Control Logic

Insertion Loss State	VC1 (Pin 1)	VC2 (Pin 20)	VC3 (Pin 19)	VC4 (Pin 18)
Standby (all ports in isolation state)	0	0	0	0
ANT to TX1	1	1	0	0
ANT to TX2	1	0	0	0
ANT to TRX8	0	1	1	0
ANT to TRX7	0	1	0	0
ANT to TRX1	0	0	1	0
ANT to TRX2	1	0	1	0
ANT to TRX3	1	1	1	0
ANT to TRX4	1	0	1	1
ANT to TRX5	1	1	1	1
ANT to TRX6	1	0	0	1

Table 5. TXx/TRXx to TXx/TRXx Isolation Matrix (1 of 2)

"On" Port	Frequency (MHz)	Isolation									
		TX1	TX2	TRX1	TRX2	TRX3	TRX4	TRX5	TRX6	TRX7	TRX8
TX1	915	-	-25	-54	-54	-56	-59	-56	-55	-47	-52
TX1	1910	-	-33	-45	-49	-52	-56	-53	-50	-36	-40
TX1	2170	-	-29	-45	-49	-52	-56	-52	-49	-36	-40
TX1	2690	-	-24	-44	-48	-51	-55	-51	-48	-35	-39
TX2	915	-29	-	-53	-53	-56	-57	-55	-51	-48	-51
TX2	1910	-31	-	-48	-47	-48	-46	-44	-40	-43	-46
TX2	2170	-29	-	-49	-47	-48	-46	-44	-40	-44	-47
TX2	2690	-24	-	-61	-65	-62	-59	-50	-49	-47	-51
TRX1	915	-67	-37	-	-30	-36	-58	-59	-58	-40	-33
TRX1	1910	-49	-31	-	-24	-30	-46	-47	-44	-34	-27
TRX1	2170	-48	-30	-	-23	-29	-44	-46	-42	-32	-26
TRX1	2690	-44	-32	-	-21	-27	-42	-44	-39	-30	-24
TRX2	915	-58	-37	-33	-	-30	-57	-60	-57	-42	-38
TRX2	1910	-50	-31	-27	-	-24	-46	-47	-44	-35	-32
TRX2	2170	-49	-30	-26	-	-23	-44	-45	-42	-34	-31
TRX2	2690	-46	-31	-24	-	-21	-42	-43	-39	-31	-29
TRX3	915	-55	-37	-37	-32	-	-56	-60	-57	-43	-40
TRX3	1910	-50	-31	-31	-26	-	-45	-46	-44	-36	-34
TRX3	2170	-49	-30	-30	-25	-	-43	-45	-42	-35	-33
TRX3	2690	-47	-31	-28	-23	-	-41	-43	-39	-32	-31
TRX4	915	-51	-38	-59	-55	-56	-	-32	-39	-60	-60
TRX4	1910	-49	-31	-51	-48	-48	-	-26	-32	-50	-52
TRX4	2170	-49	-30	-49	-46	-46	-	-25	-31	-48	-50
TRX4	2690	-46	-31	-47	-44	-44	-	-22	-28	-45	-48
TRX5	915	-51	-38	-58	-55	-56	-34	-	-32	-59	-59
TRX5	1910	-50	-31	-50	-47	-48	-28	-	-26	-50	-51
TRX5	2170	-49	-30	-49	-46	-46	-27	-	-25	-48	-49
TRX5	2690	-47	-32	-46	-44	-44	-24	-	-22	-45	-47
TRX6	915	-50	-39	-58	-55	-56	-40	-36	-	-58	-59
TRX6	1910	-51	-32	-50	-47	-48	-33	-29	-	-49	-51
TRX6	2170	-50	-31	-48	-46	-46	-31	-28	-	-47	-49
TRX6	2690	-47	-32	-46	-44	-44	-29	-25	-	-44	-47

Table 5. TXx/TRXx to TXx/TRXx Isolation Matrix (2 of 2)

"On" Port	Frequency (MHz)	Isolation									
		TX1	TX2	TRX1	TRX2	TRX3	TRX4	TRX5	TRX6	TRX7	TRX8
TRX7	915	-37	-36	-36	-39	-41	-59	-59	-57	-	-30
TRX7	1910	-40	-31	-31	-32	-35	-47	-47	-44	-	-25
TRX7	2170	-38	-30	-30	-31	-34	-45	-46	-42	-	-23
TRX7	2690	-36	-32	-28	-29	-31	-43	-44	-39	-	-21
TRX8	915	-51	-37	-30	-36	-39	-59	-59	-58	-37	-
TRX8	1910	-45	-31	-24	-30	-33	-47	-47	-44	-30	-
TRX8	2170	-43	-30	-23	-28	-32	-45	-46	-42	-29	-
TRX8	2690	-40	-32	-21	-26	-30	-43	-44	-39	-27	-

Table 6. ANT to TXx/TRXx Isolation Matrix (1 of 2)

"On" Port	Frequency (MHz)	Isolation									
		TX1	TX2	TRX1	TRX2	TRX3	TRX4	TRX5	TRX6	TRX7	TRX8
TX1	915	-	-26	-54	-53	-54	-46	-44	-42	-48	-52
TX1	1910	-	-35	-55	-61	-65	-41	-39	-39	-42	-49
TX1	2170	-	-32	-54	-62	-69	-42	-39	-40	-41	-48
TX1	2690	-	-31	-49	-51	-54	-41	-38	-39	-38	-45
TX2	915	-34	-	-57	-55	-55	-47	-45	-42	-56	-57
TX2	1910	-32	-	-46	-45	-46	-39	-37	-34	-41	-45
TX2	2170	-31	-	-44	-43	-44	-38	-36	-33	-40	-43
TX2	2690	-33	-	-43	-42	-43	-36	-34	-32	-39	-42
TRX1	915	-41	-48	-	-38	-47	-47	-45	-43	-50	-45
TRX1	1910	-49	-38	-	-31	-39	-41	-39	-37	-39	-36
TRX1	2170	-48	-36	-	-31	-38	-39	-38	-36	-37	-35
TRX1	2690	-44	-34	-	-30	-37	-37	-36	-34	-34	-34
TRX2	915	-42	-49	-43	-	-36	-47	-46	-43	-47	-55
TRX2	1910	-48	-38	-35	-	-30	-41	-39	-37	-38	-41
TRX2	2170	-46	-37	-34	-	-29	-40	-38	-36	-36	-40
TRX2	2690	-44	-34	-34	-	-29	-38	-36	-34	-34	-38
TRX3	915	-42	-49	-52	-43	-	-48	-46	-43	-46	-53
TRX3	1910	-47	-39	-40	-34	-	-41	-40	-37	-38	-41
TRX3	2170	-46	-37	-39	-33	-	-40	-38	-36	-36	-39
TRX3	2690	-44	-35	-38	-32	-	-38	-36	-34	-33	-37

Table 6. ANT to TXx/TRXx Isolation Matrix (2 of 2)

"On" Port	Frequency (MHz)	Isolation									
		TX1	TX2	TRX1	TRX2	TRX3	TRX4	TRX5	TRX6	TRX7	TRX8
TRX4	915	-43	-51	-53	-53	-55	-	-41	-46	-51	-53
TRX4	1910	-47	-40	-47	-46	-47	-	-33	-35	-45	-47
TRX4	2170	-46	-39	-46	-45	-45	-	-31	-34	-44	-45
TRX4	2690	-44	-36	-44	-42	-42	-	-30	-31	-41	-43
TRX5	915	-44	-53	-54	-53	-55	-51	-	-43	-51	-53
TRX5	1910	-47	-41	-47	-46	-48	-36	-	-32	-45	-47
TRX5	2170	-46	-40	-46	-45	-46	-34	-	-31	-44	-46
TRX5	2690	-44	-36	-44	-43	-44	-32	-	-29	-41	-43
TRX6	915	-44	-61	-54	-53	-55	-47	-51	-	-52	-53
TRX6	1910	-48	-47	-47	-46	-48	-37	-36	-	-46	-47
TRX6	2170	-47	-44	-46	-45	-46	-36	-34	-	-44	-46
TRX6	2690	-44	-36	-44	-43	-44	-33	-32	-	-41	-43
TRX7	915	-32	-45	-50	-51	-50	-47	-45	-43	-	-37
TRX7	1910	-49	-37	-40	-39	-40	-40	-39	-37	-	-31
TRX7	2170	-49	-37	-39	-37	-38	-39	-38	-36	-	-30
TRX7	2690	-43	-35	-38	-35	-36	-37	-36	-34	-	-30
TRX8	915	-38	-47	-36	-51	-56	-47	-45	-43	-48	-
TRX8	1910	-51	-38	-30	-39	-41	-40	-39	-37	-35	-
TRX8	2170	-50	-36	-30	-38	-39	-39	-38	-36	-33	-
TRX8	2690	-44	-34	-29	-36	-37	-37	-36	-34	-30	-

Table 7. Insertion Loss Matrix

State	Frequency (MHz)							
	704	824	915	960	1710	1910	2170	2690
TX1	-1.12	-1.20	-1.37	-1.51	-	-	-	-
TX2	-0.83	-0.87	-0.87	-0.88	-0.96	-1.07	-1.42	-7.47
TRX1	-0.58	-0.60	-0.60	-0.60	-0.60	-0.59	-0.60	-0.93
TRX2	-0.52	-0.54	-0.54	-0.54	-0.56	-0.53	-0.54	-0.86
TRX3	-0.59	-0.62	-0.62	-0.62	-0.64	-0.61	-0.60	-0.89
TRX4	-0.50	-0.52	-0.52	-0.52	-0.57	-0.53	-0.49	-0.68
TRX5	-0.56	-0.58	-0.58	-0.58	-0.59	-0.55	-0.52	-0.79
TRX6	-0.58	-0.60	-0.59	-0.60	-0.59	-0.55	-0.54	-0.93
TRX7	-0.61	-0.63	-0.63	-0.64	-0.66	-0.65	-0.66	-1.00
TRX8	-0.59	-0.61	-0.61	-0.61	-0.61	-0.57	-0.58	-0.94

Typical Performance Characteristics

($V_{DD} = 2.85\text{ V}$, $VC1 = VC2 = VC3 = VC4 = 0/1.8\text{ V}$, $T_{OP} = +25\text{ }^{\circ}\text{C}$, $P_{IN} = 0\text{ dBm}$, Characteristic Impedance [Z_0] = $50\text{ }\Omega$, Unless Otherwise Noted)

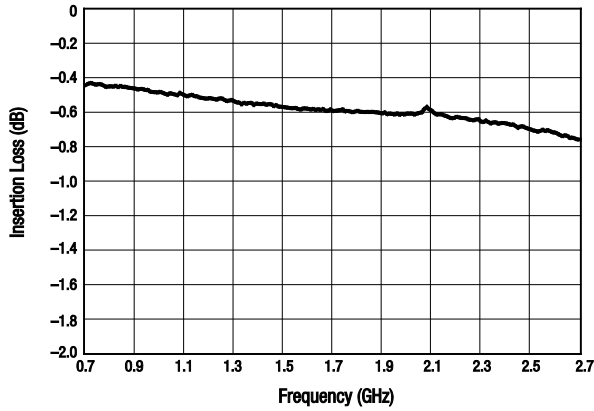

Figure 3. Insertion Loss vs Frequency (ANT to All TRX Ports)

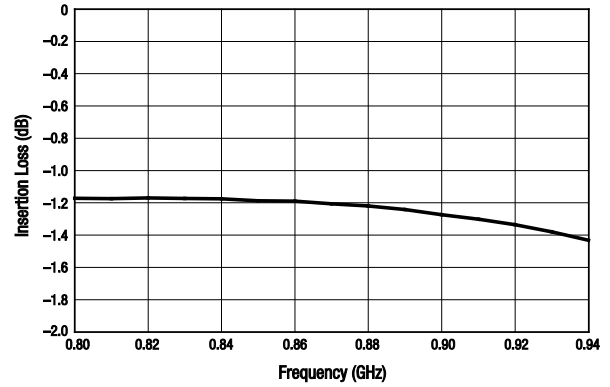

Figure 4. Insertion Loss vs Frequency (ANT to TX1 Port)

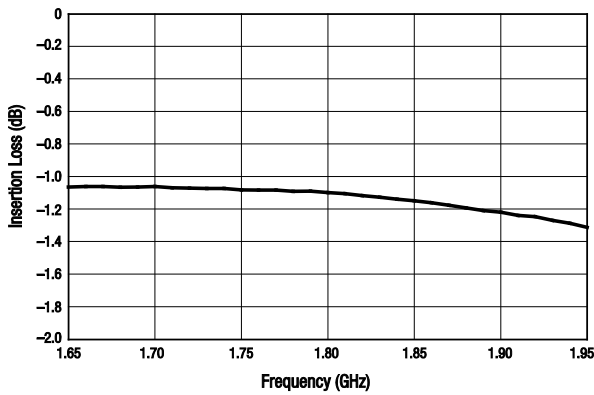

Figure 5. Insertion Loss vs Frequency (ANT to TX2 Port)

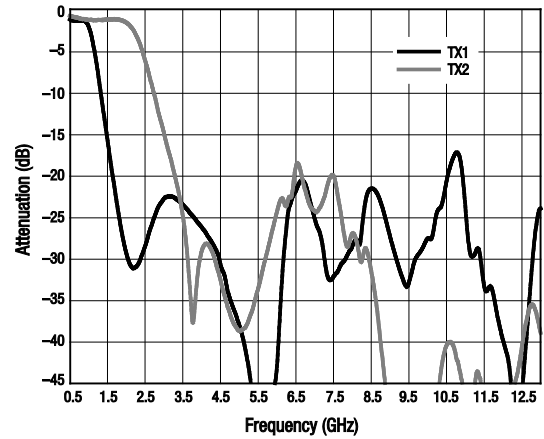

Figure 6. Attenuation vs Frequency (ANT to TX1/2 Ports)

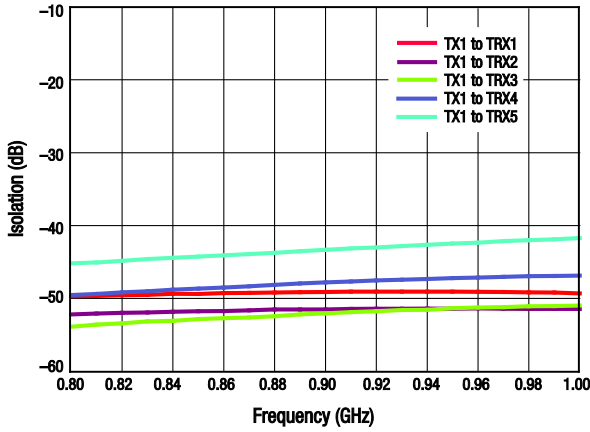

Figure 7. Isolation vs Frequency (TX1 to TRX Ports)

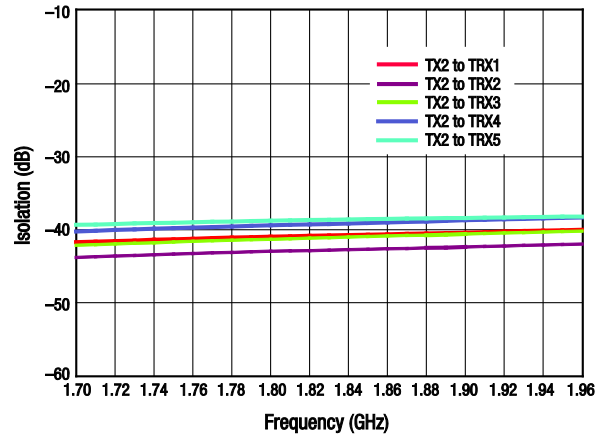

Figure 8. Isolation vs Frequency (GSM_TX_HB to TRX Ports)

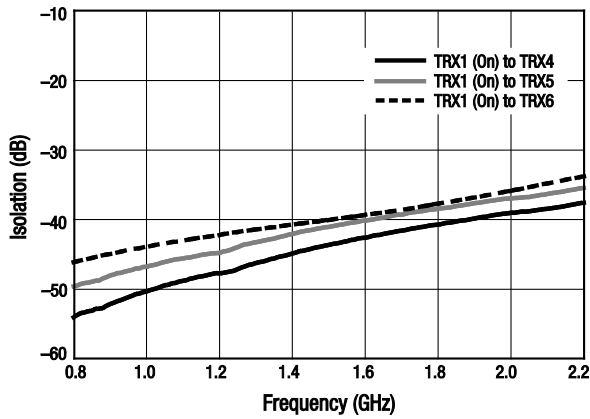

Figure 9. Isolation vs Frequency (TRX1 to TRX4/5/6 Ports)

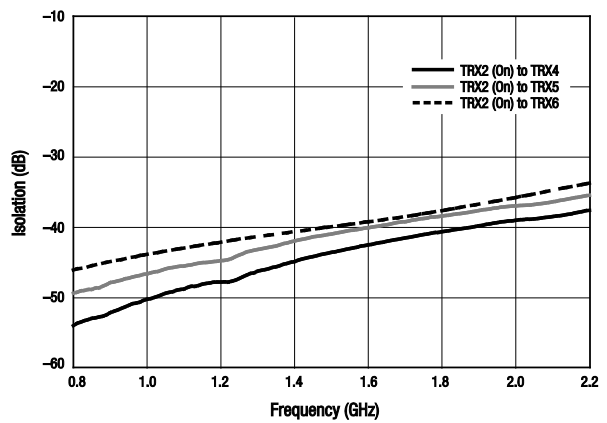

Figure 10. Isolation vs Frequency (TRX2 to TRX4/5/6 Ports)

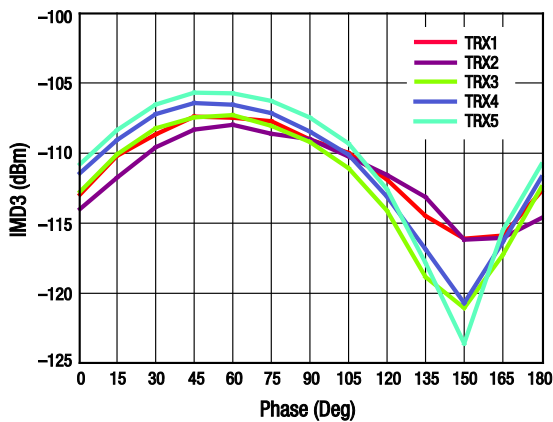

Figure 11. 3rd Order Intermodulation Distortion vs Phase, TRX Ports ($f_{\text{FUND}} = 1.95 \text{ GHz}$, $f_{\text{BLK}} = 1.76 \text{ GHz}$, $f_{\text{RX}} = 2.14 \text{ GHz}$)

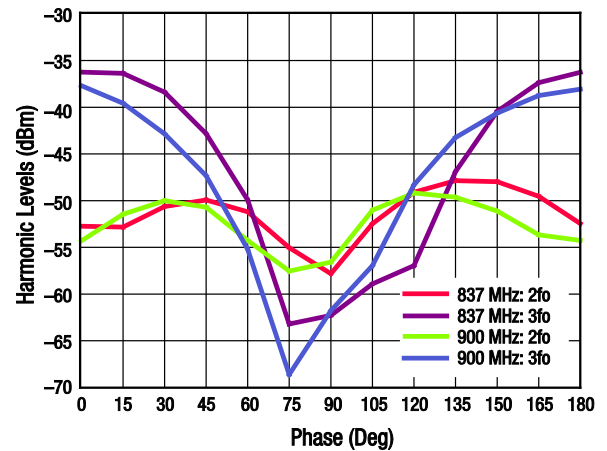

Figure 12. Harmonics vs Phase (ANT to TX1, $P_{\text{IN}} = +35 \text{ dBm}$, 5:1 VSWR Mismatch)

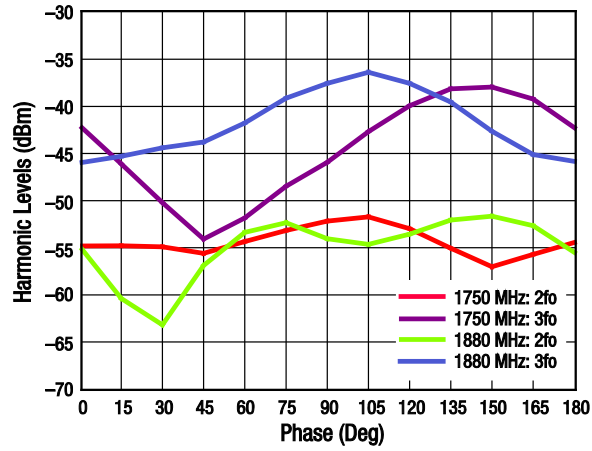

Figure 13. Harmonics vs Phase
(ANT to TX2, P_{IN} = +33 dBm, 5:1 VSWR Mismatch)

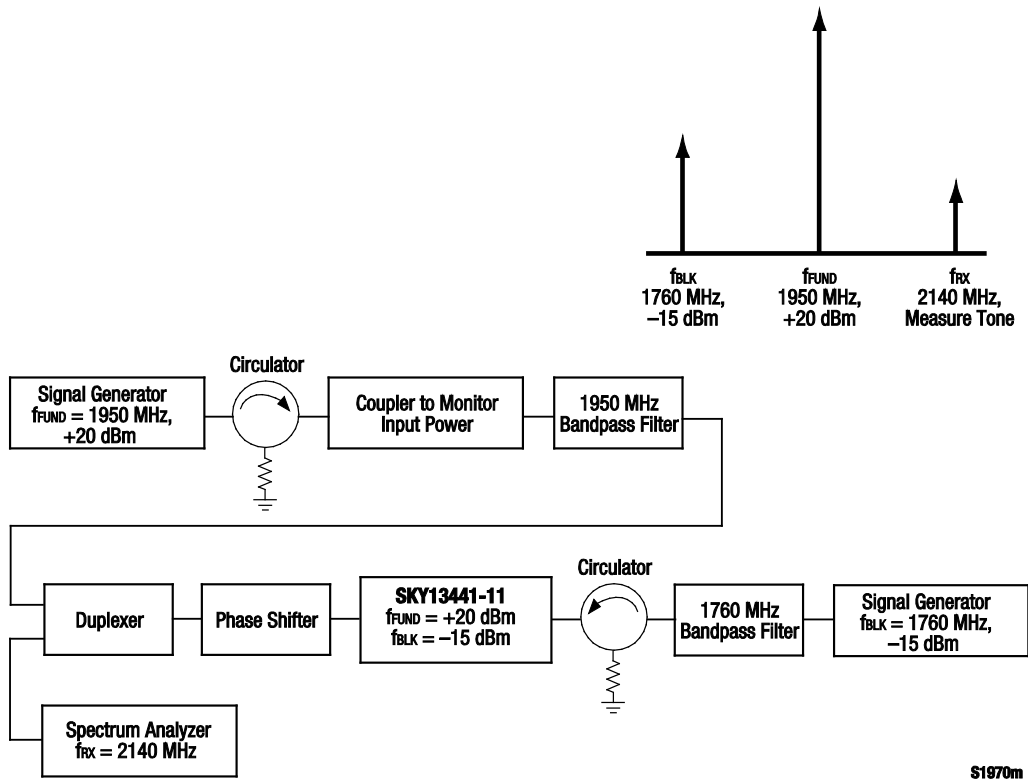

Figure 14. 3rd Order Intermodulation Test Setup

Evaluation Board Description

The SKY13441 Evaluation Board is used to test the performance of the SKY13441 SP10T Switch. An Evaluation Board schematic diagram is provided in Figure 15. A recommended ESD protection circuit diagram is provided in Figure 16. An assembly drawing for the Evaluation Board is shown in Figure 17.

Package Dimensions

The PCB layout footprint for the SKY13441 is provided in Figure 18. Typical case markings are shown in Figure 19. Package dimensions for the 20-pin MCM are shown in Figure 20, and tape and reel dimensions are provided in Figure 21.

Package and Handling Information

Since the device package is sensitive to moisture absorption, it is baked and vacuum packed before shipping. Instructions on the shipping container label regarding exposure to moisture after the container seal is broken must be followed. Otherwise, problems related to moisture absorption may occur when the part is subjected to high temperature during solder assembly.

THE SKY13441 is rated to Moisture Sensitivity Level 3 (MSL3) at 260 °C. It can be used for lead or lead-free soldering. For additional information, refer to the Skyworks Application Note, *PCB Design and SMT Assembly/Rework Guidelines for MCM-L Packages*, document number 101752.

Care must be taken when attaching this product, whether it is done manually or in a production solder reflow environment. Production quantities of this product are shipped in a standard tape and reel format.

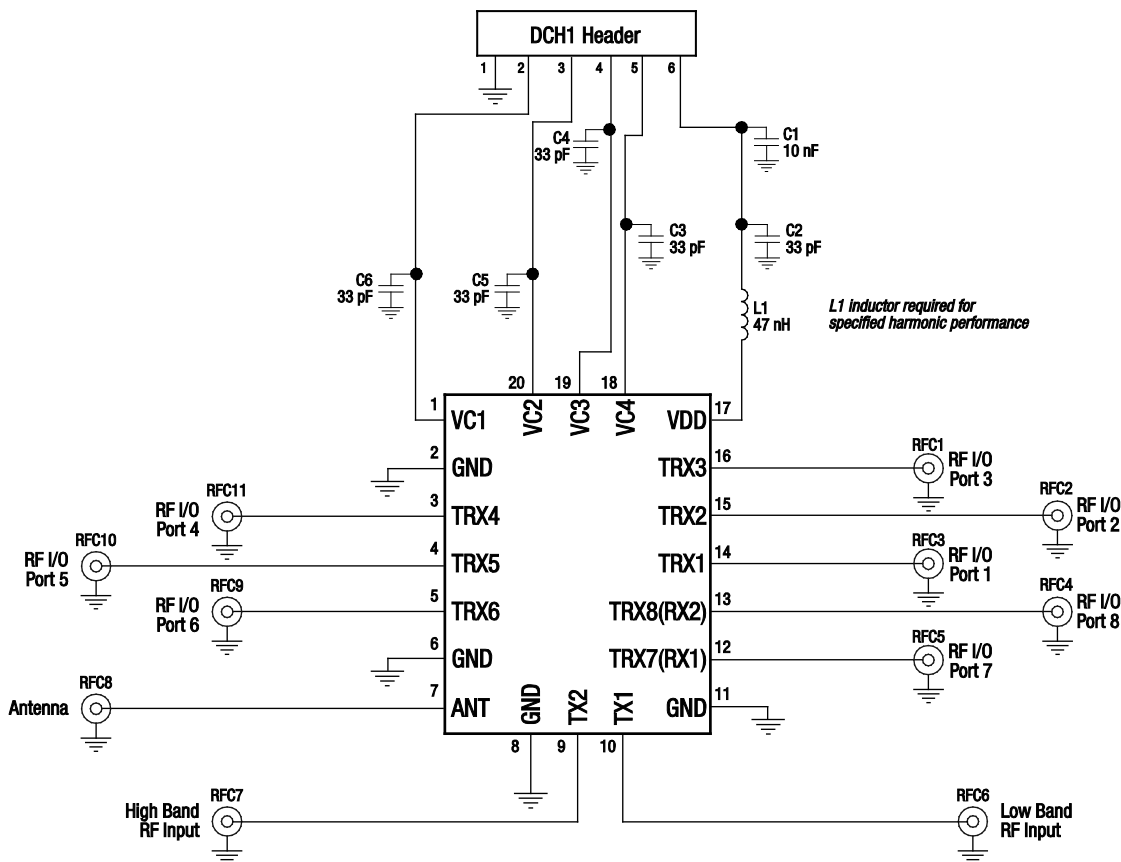

S3261

Figure 15. SKY13441 Evaluation Board Schematic

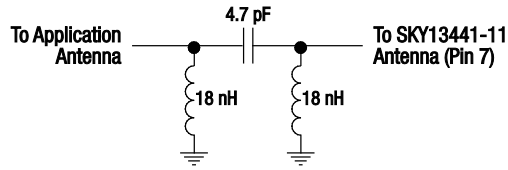

ESD Circuit 1

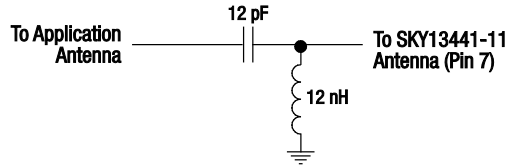

ESD Circuit 2

S2620g

Figure 16. SKY13441 Recommended ESD Protection Circuits

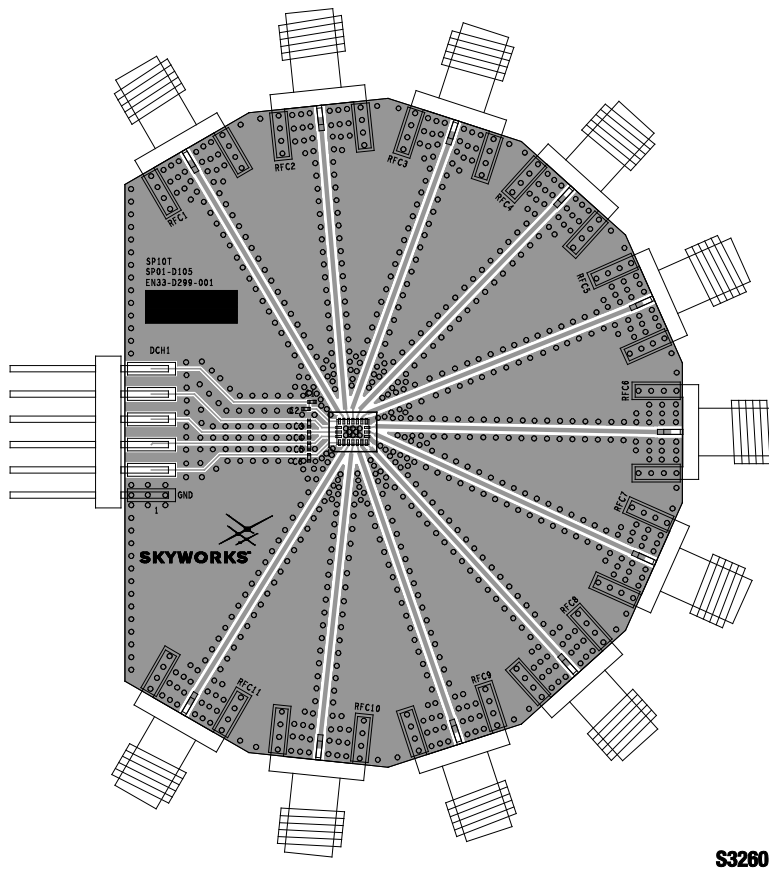

S3260

Figure 17. SKY13441 Evaluation Board Assembly Diagram

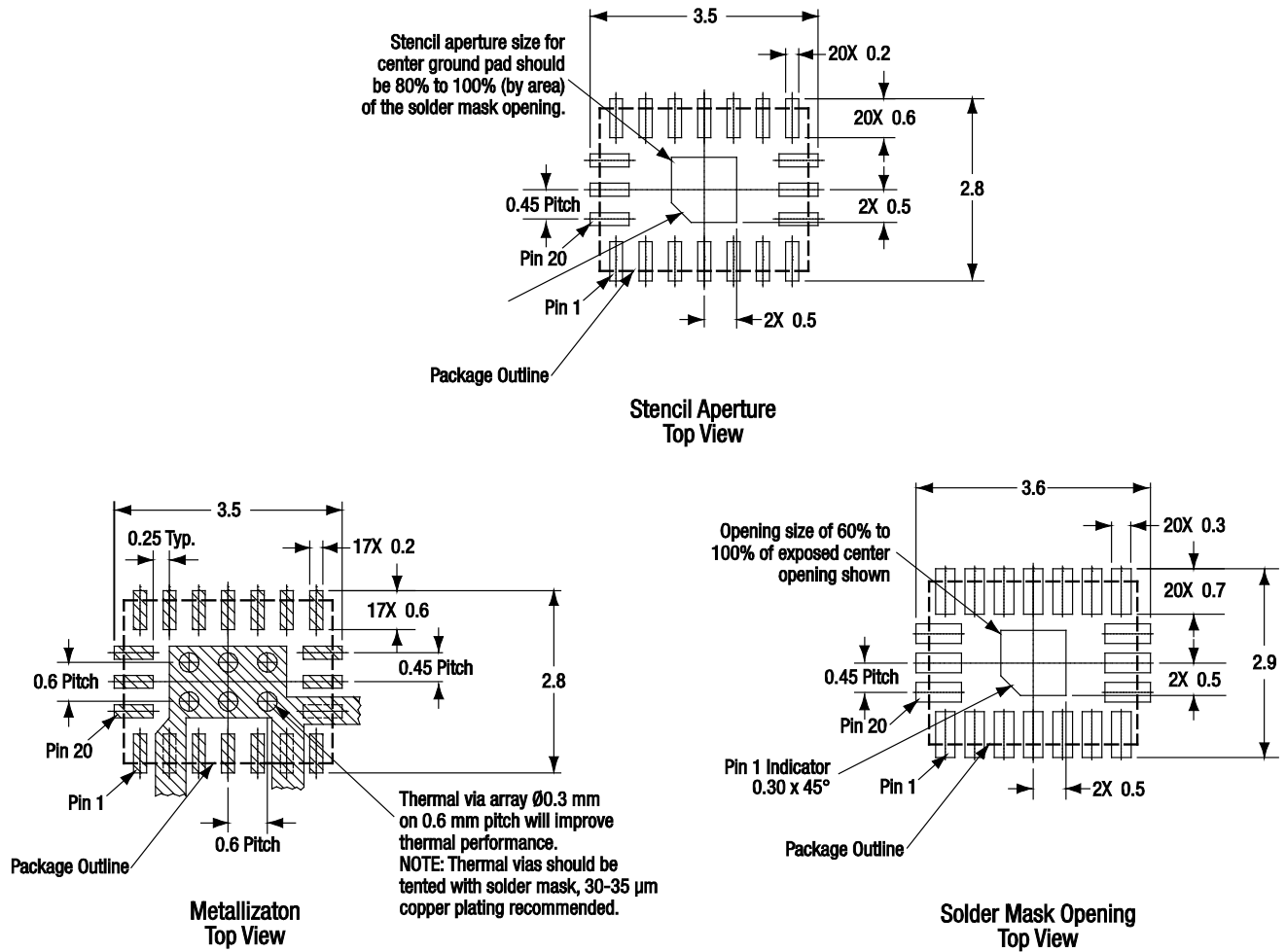

All dimensions are in millimeters

S3012

Figure 18. SKY13441 PCB Layout Footprint (Top View)

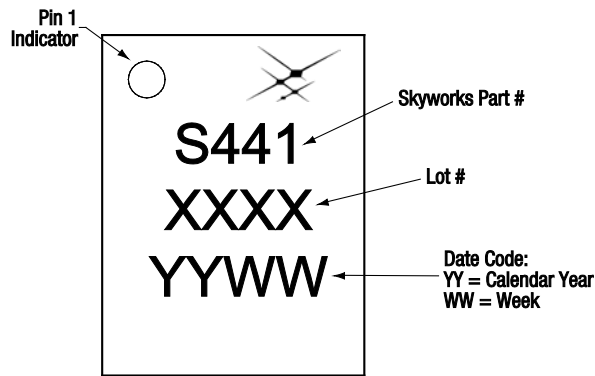

Figure 19. Typical Part Markings (Top View)

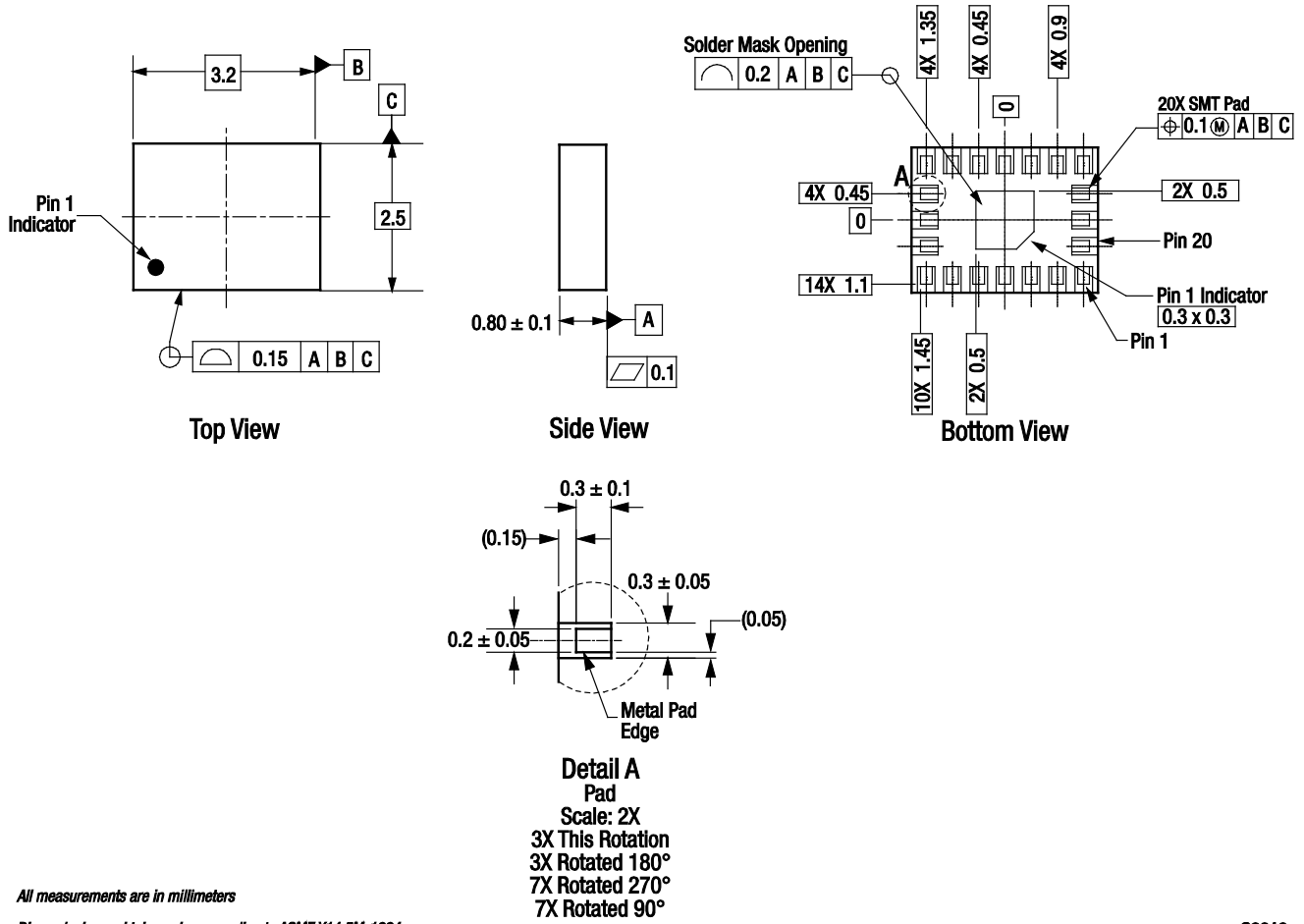
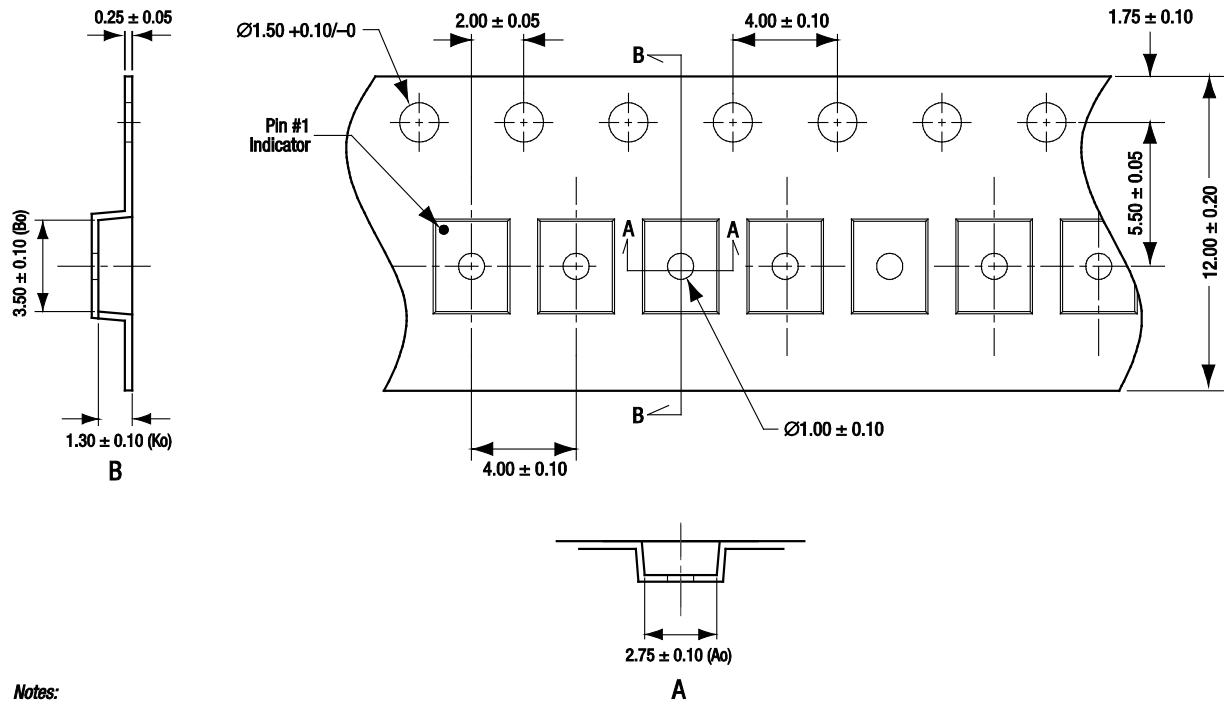

Figure 20. SKY13441 20-Pin MCM Package Dimensions

DATA SHEET • SKY13441 SP10T SWITCH WITH GPIO INTERFACE



Notes:

1. Carrier tape: black conductive polycarbonate.
2. Cover tape material: transparent conductive material.
3. ESD-surface resistivity is $\leq 1 \times 10^{10}$ Ohms/square per EIA, JEDEC TNR Specification.
4. 10 sprocket hole pitch cumulative tolerance: ± 0.20 mm
5. Ao and Bo measured on plane 0.30 mm above the bottom of the pocket.
6. All measurements are in millimeters.

S2686

Figure 21. SKY13441 Tape and Reel Dimensions